



Rosyth School  
Preliminary Examination 2013  
Primary 6 Mathematics

Name: \_\_\_\_\_ Register No. \_\_\_\_\_

Class: Pr 6 - \_\_\_\_\_

Date: 27<sup>th</sup> August 2013 Parent's Signature: \_\_\_\_\_

Total Time for Booklets A and B : 50 minutes

---

**PAPER 1**  
**(Booklet A)**

Instructions to Pupils:

1. Do not open this booklet until you are told to do so.
2. Follow all instructions carefully.
3. Shade your answers in the Optical Answer Sheet (OAS) provided.
4. You are **not** allowed to use a calculator
5. Answer all questions.

Section	Maximum Mark	Marks Obtained
Paper 1 (Booklet A)	20	

\* This booklet consists of 7 pages (including this cover page)

This paper is not to be reproduced in part or whole without the permission of the Principal.

Questions 1 to 10 carry 1 mark each. Questions 11 to 15 carry 2 marks each. For each question, four options are given. One of them is the correct answer. Make your choice (1, 2, 3 or 4). Shade the oval (1, 2, 3 or 4) on the Optical Answer Sheet.

(20 marks)

---

1. Express  $3\frac{3}{4}$  as an improper fraction.

(1)  $\frac{9}{4}$

(2)  $\frac{13}{4}$

(3)  $\frac{15}{4}$

(4)  $\frac{33}{4}$

2. Which of the following is the smallest?

(1)  $\frac{2}{3}$

(2)  $\frac{3}{5}$

(3) 0.606

(4) 0.66

3. The value of  $3 + 4 \times 6 - (6 \times 2) \div 3$  is \_\_\_\_\_.

(1) 5

(2) 10

(3) 23

(4) 38

4. Express 5.6% as a decimal.

- (1) 0.056
- (2) 5.6
- (3) 56
- (4) 560

5. The pie chart shows the proportion of blue, red and green files a shopkeeper has. AB is a straight line. If he has 45 green files, how many red files does he have?

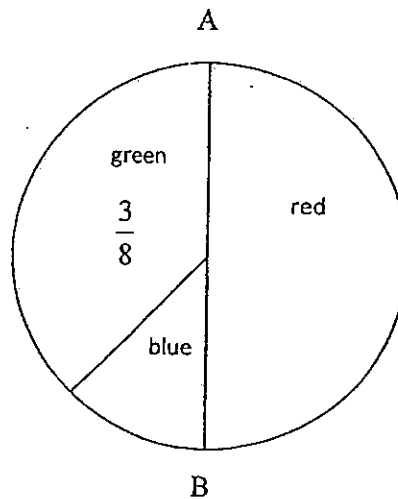

- (1) 15
- (2) 18
- (3) 60
- (4) 120

6. A machine can print 120 pages in 4 minutes. At this rate, how long will it take to print 12 000 pages?

- (1) 10 min
- (2) 40 min
- (3) 100 min
- (4) 400 min

7. How many  $\frac{1}{4}$  h are there in  $3\frac{1}{2}$  h?

- (1) 6
- (2) 7
- (3) 13
- (4) 14

8. ABCD is a trapezium. AB is parallel to DC.  
Which one of the following statements is true?

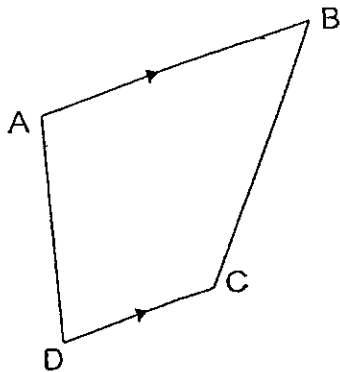

- (1)  $\angle DAB = \angle ADC$
- (2)  $\angle DAB + \angle ADC = 180^\circ$
- (3)  $\angle DAB + \angle ABC = 180^\circ$
- (4)  $\angle DAB = \angle DCB$

9. Sandy and Ben saved a total of \$y. Sandy saved \$5 less than Ben. How much did Sandy save?

- (1)  $\$(y - 5)$
- (2)  $\$(y + 5)$
- (3)  $\$(\frac{y - 5}{2})$
- (4)  $\$(\frac{y + 5}{2})$

10.

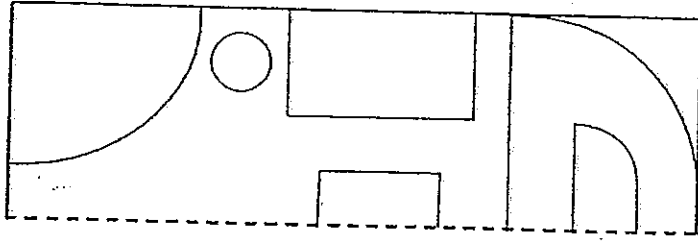

The top half of a symmetric figure is shown above.

Which one of the following completes the symmetric figure?

(1)

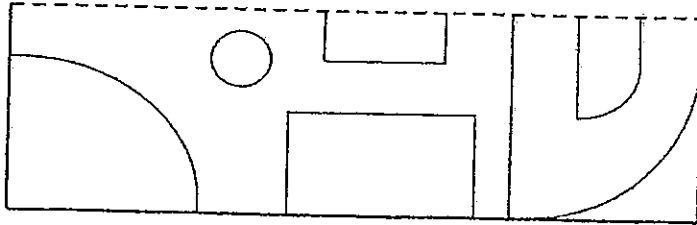

(2)

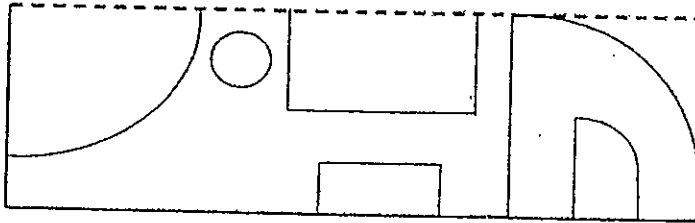

(3)

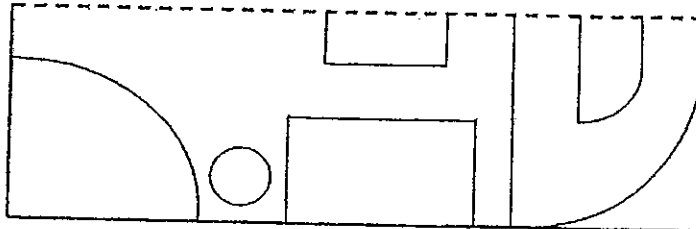

(4)

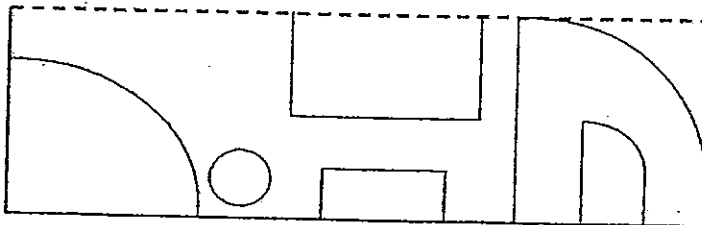

11. Mrs Tan had 15 kg of flour. She packed the flour equally into bags, each weighing  $\frac{4}{5}$  kg. How much flour was left unpacked ?

(1)  $\frac{1}{4}$  kg

(2)  $\frac{3}{4}$  kg

(3)  $\frac{1}{5}$  kg

(4)  $\frac{3}{5}$  kg

12. James and Bond left Town X at the same time. James drove at 60 km/h while Bond drove at 90 km/h. How long would it take for Bond to be 90 km ahead of James?

(1)  $\frac{1}{3}$  hour

(2)  $\frac{2}{3}$  hour

(3) 1 hour

(4) 3 hours

13. Ali is  $x$  years older than Hassan. Four years later, Hassan's age is half of Ali's age. How old is Ali now? Express your answer in terms of  $x$ .

(1)  $(2x - 4)$  years

(2)  $(2x - 8)$  years

(3)  $(2x + 4)$  years

(4)  $(2x + 8)$  years

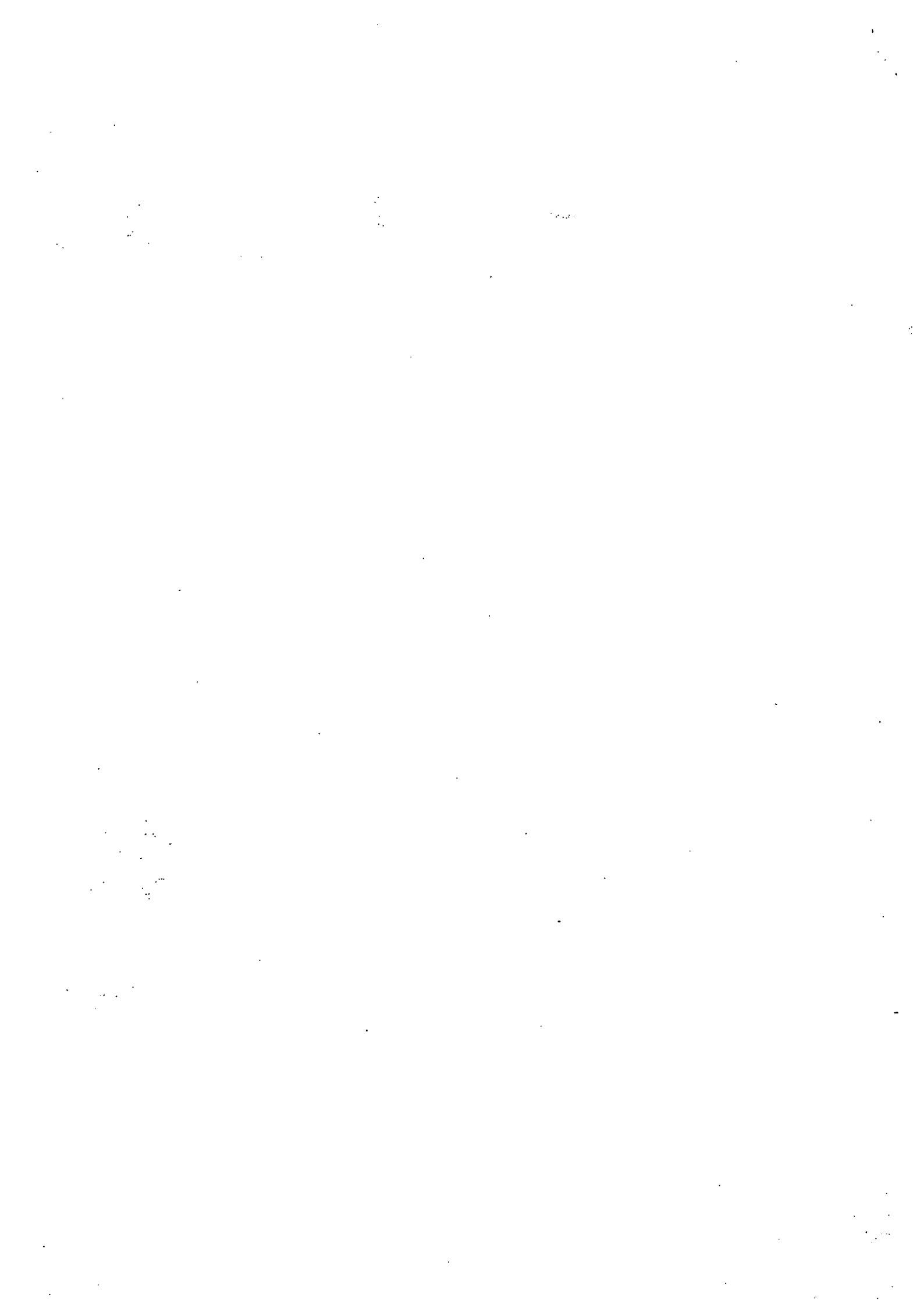

14. In the figure, the circle touches each of the two equilateral triangles at exactly three points. What fraction of the figure is shaded?

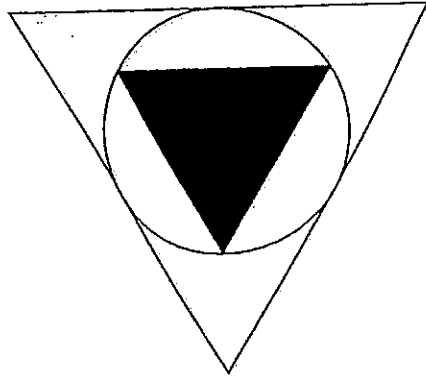

- (1)  $\frac{1}{2}$   
(2)  $\frac{1}{3}$   
(3)  $\frac{1}{4}$   
(4)  $\frac{1}{5}$
15. The ratio of the number of boys to the number of girls in a Math club was 5 : 7. When 24 boys left, the membership was decreased to  $\frac{3}{4}$  of its original enrolment. How many boys were there at first?

- (1) 16  
(2) 32  
(3) 40  
(4) 72





**Rosyth School**  
**Preliminary Examination 2013**  
**Primary 6 Mathematics**

Name: \_\_\_\_\_ Register No. \_\_\_\_\_

Class: Pr 6 \_\_\_\_\_

Date: 27<sup>th</sup> August 2013 Parent's Signature: \_\_\_\_\_

Total Time for Booklets A and B : 50 minutes

**PAPER 1**  
**(Booklet B)**

Instructions to Pupils:

1. Do not open this booklet until you are told to do so.
2. Follow all instructions carefully.
3. You are **not** allowed to use a calculator
4. Answer all questions.

Section	Maximum Mark	Marks Obtained
Paper 1 (Booklet B)	20	

\* This booklet consists of 7 pages (including this cover page)

This paper is not to be reproduced in part or whole without the permission of the Principal.

Questions 16 to 25 carry 1 mark each. Write your answers in the spaces provided. For questions which require units, give your answers in the units stated.

(10 marks)

---

16. Evaluate  $2\frac{1}{2} - 1\frac{2}{3} + 3\frac{4}{5}$ . Express your answer in the simplest form.

Ans: \_\_\_\_\_

17. The ratio of Anna's age to Bridgitte's age is 3 : 4. The ratio of Bridgitte's age to Carmen's age is 5 : 8. Express Anna's age as a ratio of the total age of the girls in its simplest form.

Ans: \_\_\_\_\_

18. What fraction of 80 minutes is 2 hours? Express your answer in the simplest form.

Ans: \_\_\_\_\_

19. How many halves are there in 15?

Ans: \_\_\_\_\_

20. What is  $\frac{3}{5}$  of 4 metres? (Express your answer in the simplest form.)

Ans: \_\_\_\_\_ m

21. Find the perimeter of a quadrant which has a radius of 14 cm. (Take  $\pi = \frac{22}{7}$ )

Ans: \_\_\_\_\_ cm

22. Mrs Chan bought 3 ℓ of lime juice and used up  $\frac{1}{4}$  ℓ. How much of the lime juice was left? Give your answer in millimetres.

Ans: \_\_\_\_\_ ml

23. Find the volume of a cube which has a total surface area of 96 cm<sup>2</sup>.

Ans: \_\_\_\_\_ cm<sup>3</sup>

24. Look at the net of the cube below. What is the letter opposite of B?

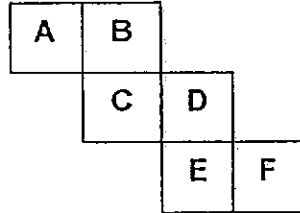

Ans: \_\_\_\_\_

25. In the figure below (not drawn to scale), UTS is a straight line. PQ is parallel to RS and  $QT = QS$ . Given that  $\angle TSQ = 30^\circ$ , find  $\angle RST$ .

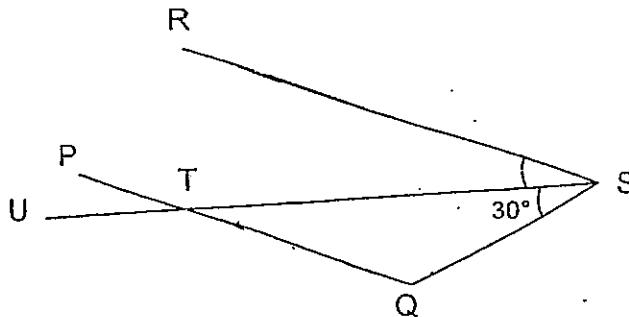

Ans: \_\_\_\_\_°

Questions 26 to 30 carry 2 marks each. Show your workings clearly in the space provided for each question and write your answers in the spaces provided. For questions which require units, give your answers in the units stated.

(10 marks)

26. What is the maximum number of books Megan can purchase with \$150?

**Storybooks on Sale!**

3 books for \$40  
OR  
1 book for \$14.50

Ans: \_\_\_\_\_

27. The pie chart below shows how Christopher spent his money during a holiday. He spent a total of \$1 200. He spent 50% more on transport than on shopping. How much did he spend on shopping?

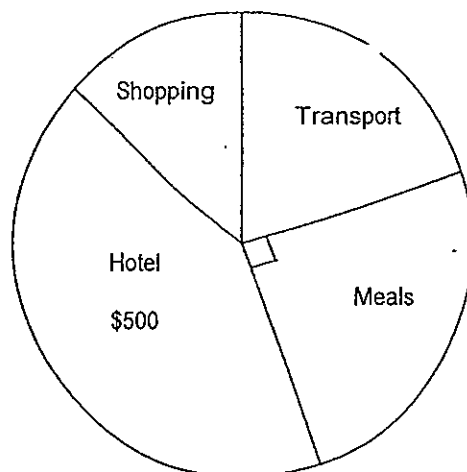

Ans: \$ \_\_\_\_\_

28. The net of a cuboid is shown below. The base has an area of  $55 \text{ cm}^2$ . Find the volume of the cuboid.

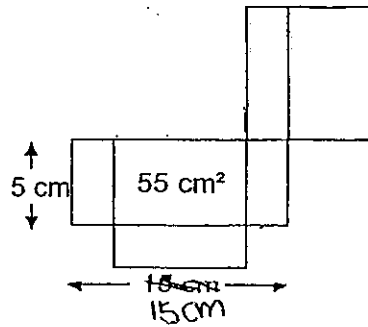

Ans: \_\_\_\_\_  $\text{cm}^3$

29. The figure below is not drawn to scale. The ratio of  $\angle x$  to  $\angle y$  to  $\angle z$  is  $2 : 3 : 7$ . Find the difference between  $\angle x$  and  $\angle z$ .

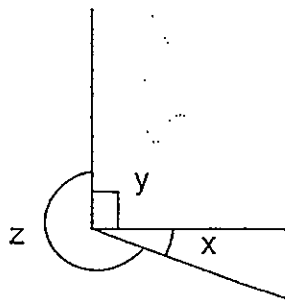

*me*

Ans: \_\_\_\_\_



30. The diagram below shows a series of consecutive odd numbers represented by the letters A to ~~F~~



$$A + C + E = 15y$$

What is the value of A? Express your answer in terms of  $y$ .

Ans: \_

End of Paper 1





Rosyth School  
Preliminary Examination 2013  
Primary 6 Mathematics

Name: \_\_\_\_\_ Register No. \_\_\_\_\_

Class: Pr 6 - \_\_\_\_\_

Date: 27<sup>th</sup> August 2013 Parent's Signature: \_\_\_\_\_

Time: 1 h 40 min

---

PAPER 2

Instructions to Pupils:

1. Do not open this booklet until you are told to do so.
2. Follow all instructions carefully.
3. **Show your workings clearly** as marks are awarded for correct working.
4. Write your answers in this booklet.
5. You are allowed to use a calculator
6. Answer all questions.

Questions	Maximum Mark	Marks Obtained
Q 1 to 5	10	
Q 6 to 18	50	

Section	Maximum Mark	Marks Obtained
Paper 1	40	
Paper 2	60	
Total	100	

\* This booklet consists of 17 pages (including this cover page)  
This paper is not to be reproduced in part or whole without the permission of the Principal.

Questions 1 to 5 carry 2 marks each. Show your working clearly in the space provided for each question and write your answers in the spaces provided. For questions which require units, give your answers in the units stated.

Do not write  
in this space

(10 marks)

- 
1. The average of 8 consecutive even numbers is 99. What is the greatest number among the 8 numbers?

---

---

---

Ans: \_\_\_\_\_

2. Mr Martino always saved 25% of his monthly salary. He received a pay rise of 8% and found that he could save \$340 more. What was Mr Martino's salary after his pay rise?

Ans: \$ \_\_\_\_\_

A survey was conducted to find out how 180 students travelled to school. The pie chart below shows the results of the survey. Refer to the pie chart below and answer Questions 3 and 4.

Do not write  
in this space

3.

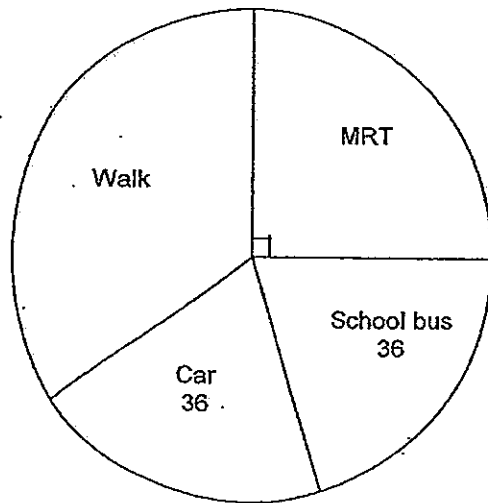

Given that the number of students who travelled by school bus was the same as those who travelled by car, what percentage of the students walk to school ?

Ans: \_\_\_\_\_ %

4. What was the ratio of the number of students who walk to school to the number of students who take MRT?

Ans: \_\_\_\_\_

5. The figure consists of a big semicircle of radius 10 cm and 4 small quadrants each of radius 5 cm. Find the perimeter of the shaded part. Leave your answer in terms of  $\pi$ . Do not write in this space

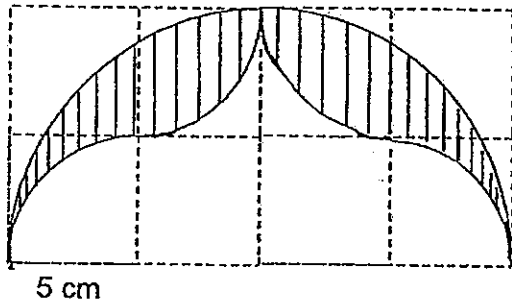

Ans: \_\_\_\_\_ cm [2m]

Questions 6 to 18, show your working clearly in the space provided for each question and write your answers in the spaces provided. The number of marks available is shown in brackets [ ] at the end of each question or part-question.

Do not write  
in this space

(50 marks)

6. Ramesh had 2 buckets X and Y, each containing some water. He poured  $\frac{3}{5}$  of the water from X into Y. After that, he poured  $\frac{1}{2}$  of the water from Y into X. The ratio of the amount of water in X to the amount of water in Y became 11 : 5. What was the ratio of the amount of water in X to the amount of water in Y at first?

Ans: \_\_\_\_\_ [3m]

Do not write  
in this space

7. Tank A which measures 80 cm by 20 cm by 30 cm was completely filled with water while Tank B was empty. The base area of Tank B is  $\frac{1}{2}$  the base area of Tank A.

Both tanks have the same height.

Water is drained from Tank A at the same rate as the water is being filled in Tank B, at  $800 \text{ cm}^3$  per minute. How long would it take for the height of the water level in both tanks to be the same?

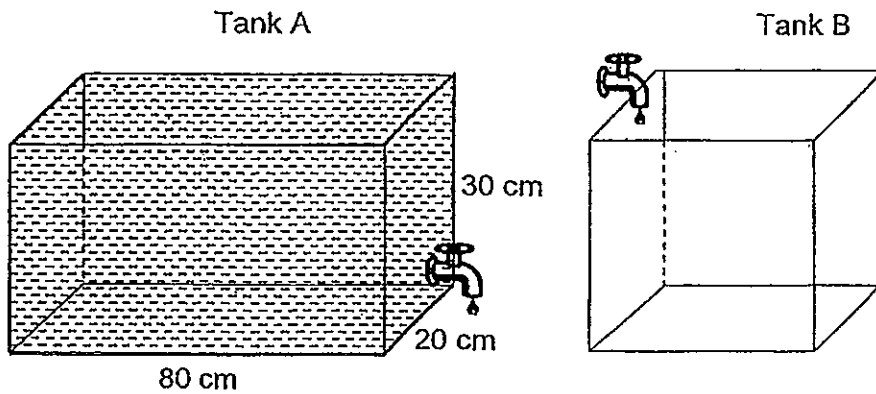

Ans: \_\_\_\_\_ [3m]

8. The graph below illustrates the survey findings of the weekly pocket money of a Primary 6 class.

Do not write in this space.

Number of students

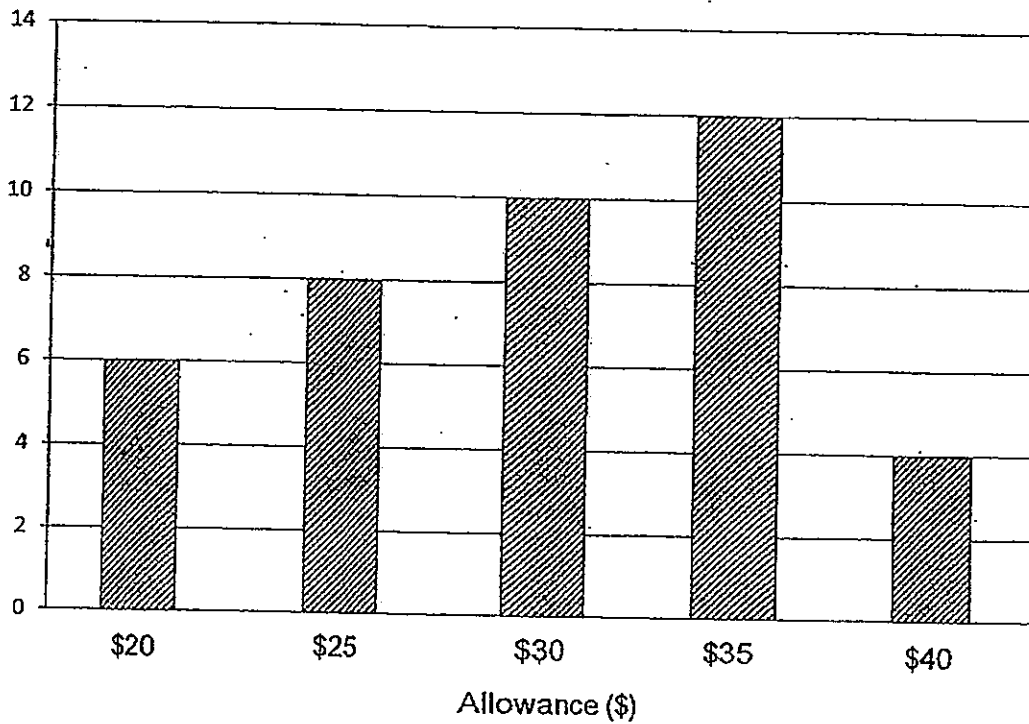

(a) Find the number of students in the class.

(b) Calculate the percentage of students whose allowance is \$30 or more.

Ans: (a) \_\_\_\_\_ [1m]

(b) \_\_\_\_\_ [2m]

9. A car travelled 18 km with 2 litres of petrol. If the petrol cost \$1.50 per litre, how far could the car travel on a full tank of petrol which cost \$84?

Do not write  
in this space

Ans: \_\_\_\_\_ [3m]



10. At a party, there was an equal number of boys and girls.  $\frac{1}{3}$  of the boys and 18 girls left the party. In the end, there were 42 children remaining behind. How many pupils were there at the party at first?

Do not write  
in this space

Ans: \_\_\_\_\_ [3m]

11. The diagram below shows a rectangle STUV. Area of triangle STW is  $30 \text{ cm}^2$  and the area of triangle SWV is  $45 \text{ cm}^2$ . Given that  $SW = VW$  and the ratio of the length of VX to the length of XU is  $2 : 3$ , find the area of TUXW.

Do not write  
in this space

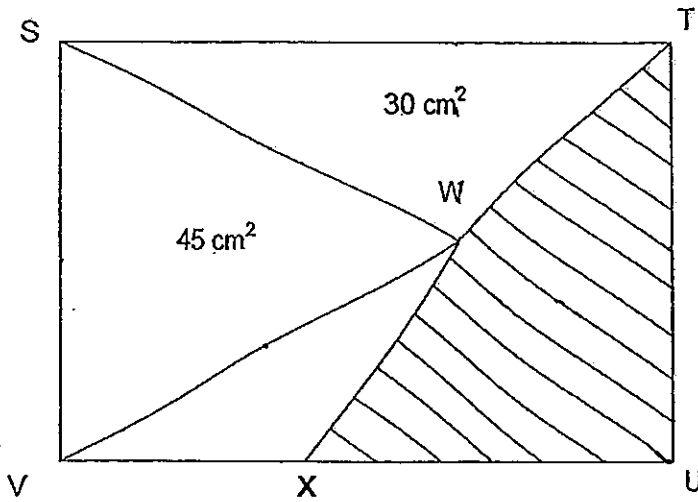

Ans: \_\_\_\_\_ [4m]

12. In the figure, find the sum of  $\angle a$ ,  $\angle b$ ,  $\angle c$  and  $\angle d$ .

Do not write  
in this space

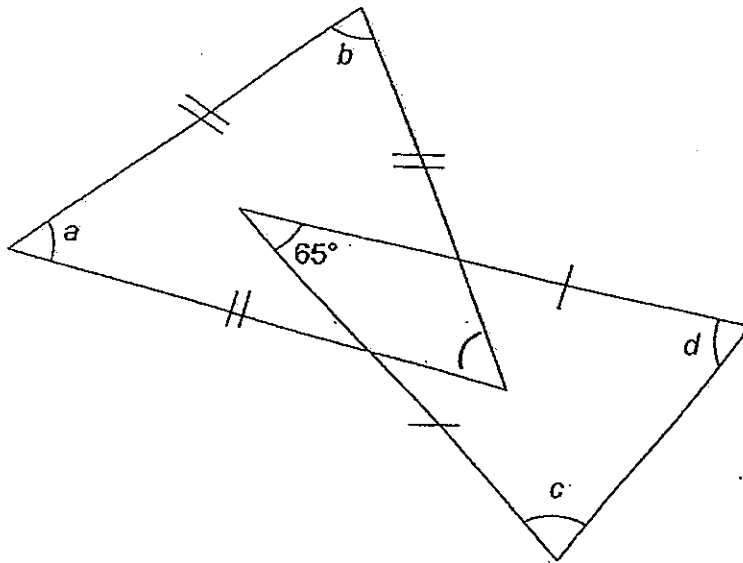

Answer : \_\_\_\_\_ [ 3 ]

13. Mark had some red and white stickers. The number of red stickers was twice the number of white ~~marbles~~ <sup>stickers</sup>. After he gave away 89 red stickers and 20 white stickers,  $\frac{1}{5}$  of the stickers left was red. Find the total number of stickers Mark had at first.

Do not write  
in this space

Ans: \_\_\_\_\_ [4m]

Do not write  
in this space

14. The diagram below shows 3 identical semicircles with an area of  $24 \text{ cm}^2$ .  
 Smaller semicircles are found in each semicircle.  
 In Figure 1, each of the 2 semicircles is identical.  
 In Figure 2, each of the 3 semicircles is identical.  
 In Figure 3, each of the 4 semicircles is identical.

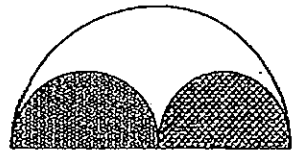

Figure 1

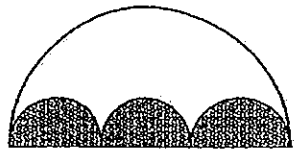

Figure 2

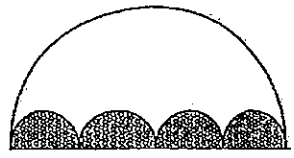

Figure 3

Fill in the information in the table below to help you analyze the pattern.

a)

Figure	Ratio of shaded region to unshaded region	Area of shaded region	Area of unshaded region	Total area
1	1 : 1	$12 \text{ cm}^2$		$24 \text{ cm}^2$
2	1 : 2	$8 \text{ cm}^2$		$24 \text{ cm}^2$
3	1 : 3	_____ [1m]	_____ [1m]	$24 \text{ cm}^2$

- b) The semicircles were rearranged to form the figure below.  
 With the above observation, find the shaded area of the following figure.

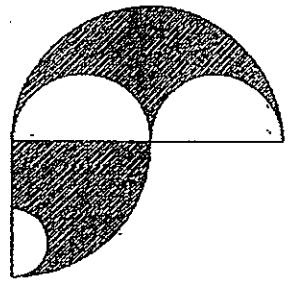

Ans: \_\_\_\_\_ [3m]

15. 20% of Jack's stamps is equal to 30% of Vindra's stamps. 25% of Jack's stamps is equal to 35% of Vindra's and Kumar's stamps. Given that Jack and Kumar had a total of \$242, how many stamps did Vindra have?

Do not write  
in this space

Ans: \_\_\_\_\_ [5m]

16. A cardboard box (Figure 1) measuring 102 cm by 33 cm by 65 cm has been opened up to form its net (not drawn to scale) as shown in Figure 2.

Do not write  
in this space

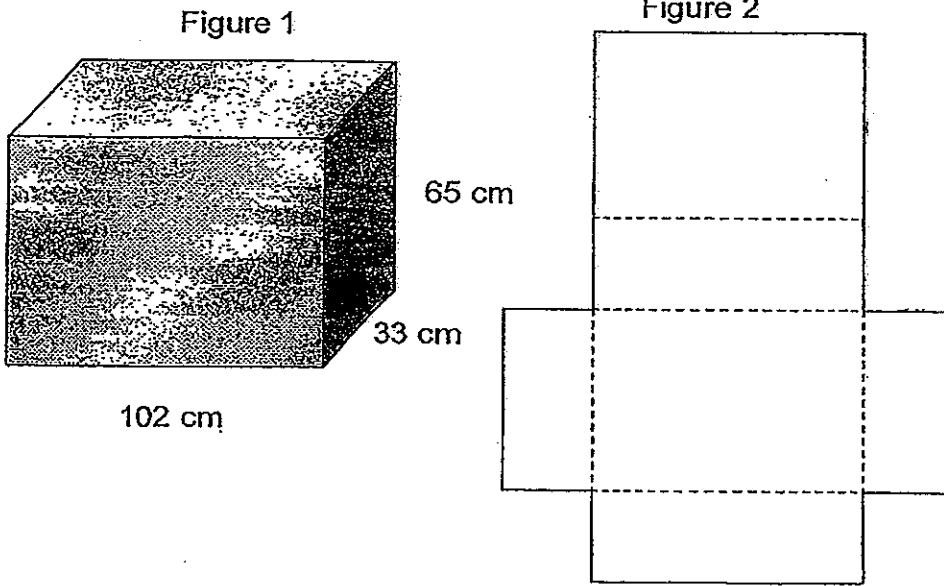

Helen then cut along the folded lines to get 6 rectangular pieces of cardboard.  
Next, she cut 10 cm squares from each of the 6 pieces of cardboard.  
What is the maximum number of pieces of squares that she can get?

Ans: \_\_\_\_\_ [4m]

17. There were 252 chocolates to be divided into three groups A, B and C.

A certain number of chocolates was selected from group A and distributed to groups B and C such that the number of chocolates in each of these two groups was doubled. Then, some chocolates were removed from group B and distributed to groups A and C, such that the number of chocolates in each of these two groups was also doubled. After that, the selection and distribution of chocolates continued from group C to group A and B. At the end, the number of chocolates in group B was twice of A while the number of chocolates in group A was twice of C. Find the number of chocolates in the largest group of chocolates at first.

Do not write  
in this space

Ans: \_\_\_\_\_ [5m]



Do not write  
in this space

18. At 9.30 a.m., Larry left Town X for Town Y which is 540 km apart.  
At 11.30 a.m., Fred started from Town Y towards Town X. They passed each other at 1.30 p.m., after Larry drove 50 km passed the midpoint of Town X and Town Y.

(a) Find the speed of Fred.

(b) At what time would Fred arrive at Town X if he continued the rest of his journey at the speed of 80 km/h?

Ans: (a) \_\_\_\_\_ [3m]

(b) \_\_\_\_\_ [2m]

End of Paper



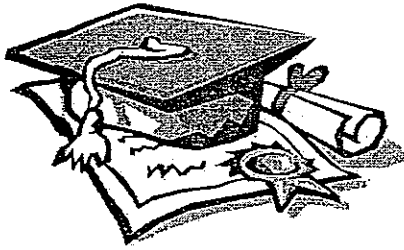

# ANSWER SHEET

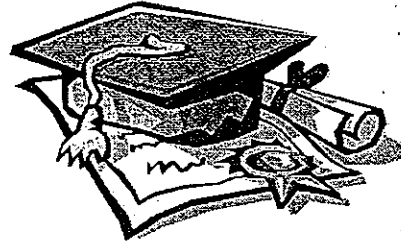

**EXAM PAPER 2013**

**SCHOOL : ROSYTH PRIMARY SCHOOL  
LEVEL : PRIMARY 6  
SUBJECT : MATHEMATICS  
TERM : SA2**

---

**Booklet A**

Q1	Q2	Q3	Q4	Q5	Q6	Q7	Q8	Q9	Q10	Q11	Q12	Q13	Q14	Q15
3	2	3	1	3	4	4	2	3	3	4	4	1	3	3

- 16.  $4\frac{19}{30}$
- 17. 15:67
- 18.  $1\frac{1}{2}$
- 19. 30
- 20. 2.4m
- 21. 50cm
- 22. 2750ml
- 23. 64
- 24. E
- 25.  $30^\circ$
- 26. 11 books
- 27. \$160
- 28.  $100\text{cm}^3$
- 29.  $150^\circ$
- 30.  $5y-4$

**Paper 2**

- 1.  $(99-1) = 98$   
 $(99+1) = 100$   
 $100+2+2+2 = 106$
- 2. 25% --- saved  
108% -- after increased  
 $25\% \times 108\% = 27\%$

$$27\% - 25\% = 2\%$$

$$2\% \text{ --- } 340$$

$$108\% \text{ -- } 18360$$

3.  $180 \times \frac{1}{4} = 45$

$$180 - 36 - 36 - 45 = 63$$

$$\frac{63}{180} \times 100\% = 35\%$$

4. 63:45

$$7:5$$

5.  $\text{Pie} \times 10 = 10\text{pie}$

$$\frac{1}{2} \times \text{pie} \times 20 = 10 \text{ pie}$$

$$10\text{pie} + 10\text{pie} = 20 \text{ pie}$$

6.

$$X : Y$$

$$11 : 5$$

$$X : Y$$

$$6 : 10$$

$$X : Y$$

$$15 : 1$$

7. Vol of water =  $80 \times 20 \times 30 = 48000$

$$80 \times 20 + 80 \times 20 \times \frac{1}{2} = 2400$$

$$\text{Height} = 48000 \div 2400 = 20$$

$$A \text{ --- } 1 \text{ min } 800 \div 1600 = 0.5$$

$$B \text{ --- } 1 \text{ min } 800 \div 800 = 1$$

$$20\text{cm} \text{ --- } 20 \text{ mins}$$

8. A.  $6 + 8 + 10 + 12 + 4 = 40$

$$B. 10 + 12 + 4 = 26$$

$$\frac{26}{40} \times 100 = 65\%$$

9. 2 L --- 18km

$$1\text{L} \text{ --- } 9\text{km}$$

$$1\text{L} \text{ -- } \$1.50$$

$$84 \div 1.50 = 56$$

$$56\text{L} \text{ --- } 56 \times 9 = 504\text{km}$$

10. 5u ---  $42 + 18 = 60$

$$1\text{u} \text{ --- } 12$$

$$6\text{u} \text{ --- } 72$$

11.  $30 + 30 = 45 + \text{WTU}$

$$\text{WTU} = 15$$

$$5\text{u} \text{ --- } 30$$

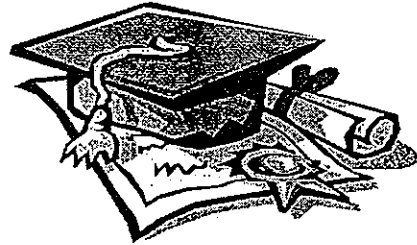

$$3u \text{ --- } 18$$

$$18+15 = 33$$

$$12. 180-65=115$$

$$180 \div 3 \times 2 = 120$$

$$120+115=235$$

$$13. 2u - 89 = 1p$$

$$1u - 20 = 4p$$

-----

$$8u - 356 = 4p$$

$$7u \text{ --- } 336$$

$$1u \text{ --- } 48$$

$$3u \text{ --- } 144$$

$$14. A. 1. 12$$

$$2. 16$$

$$3. 6 / 18$$

$$b. 6 \div 4 = 1.5$$

$$9 + 1.5 = 10.5$$

$$10.5 + 12 = 22.5$$

$$15. 20\% J = 30\% V$$

$$1/5 J = 3/10 V$$

$$3/15 J = 3/10 V$$

$$J : V$$

$$15 : 10$$

$$3 : 2$$

$$25\% J = 35\% K + V$$

$$1/4 J = 7/20 V + K$$

$$7/28 J = 7/20 V + K$$

$$J : V + K$$

$$28 : 20$$

$$J : V : K$$

$$21 : 14 : 1$$

$$22u \text{ ---- } 242$$

$$1u \text{ ---- } 11$$

$$14u \text{ --- } 154$$

$$16. 102 \div 10 = 10R2$$

$$33 \div 10 = 3R3$$

$$65 \div 10 = 6R5$$

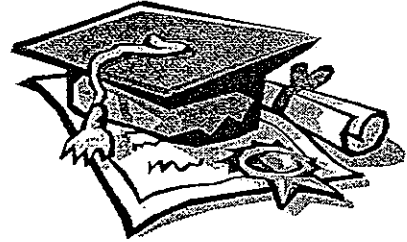

$$10 \times 3 \times 2 + 10 \times 6 \times 2 + 3 \times 6 \times 2 = 216$$

17. A:B:C:T

2:4:1:7

$$7u \text{ --- } 252$$

$$1u \text{ --- } 36$$

$$2u \text{ --- } 72$$

$$4u \text{ --- } 144$$

A : B : C

$$72:144:36$$

$$\text{-----}$$
$$36:72:144$$

$$\text{-----}$$
$$18:162:72$$

$$\text{-----}$$
$$135:81:36$$

Ans: 135

18. A.  $540 \div 2 = 270$

$$270 + 50 = 320$$

$$540 - 320 = 220$$

$$220 \div 2 = 110 \text{ km/h}$$

B.  $320 \div 80 = 4 \text{ hr}$

$$4 \text{ hr} + 2 \text{ hr} = 6 \text{ hr}$$

$$11:30 + 6 \text{ hr} = 5:30 \text{ pm}$$

