



## PRIMARY 4 MID -YEAR EXAMINATION 2012

Name : \_\_\_\_\_ ( ) Date: 14 May 2012

Class : Primary 4 ( )

Time: 8.00 a.m. - 9.30 a.m.

Duration : 1 hour 30 minutes

Parent's Signature : \_\_\_\_\_

Marks: \_\_\_\_\_ / 60

## **SCIENCE BOOKLET A**

### INSTRUCTIONS TO CANDIDATES

Write your name, class and register number.

Do not turn over this page until you are told to do so.







Follow all instructions carefully.

Answer all questions.

**Section A (30 x 2 marks)**

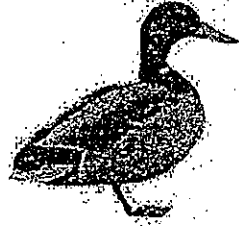
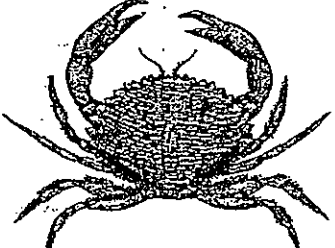
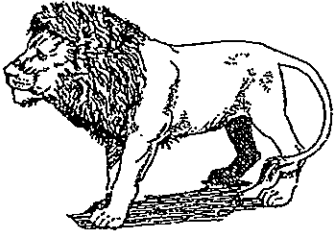
For each question, choose the most suitable answer and shade its corresponding oval (1, 2, 3 or 4) in the optical answer sheet.

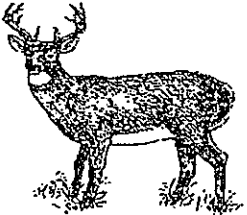
1. The table below shows some animals which are classified into different groups, A, B and C.

Group A	Group B	Group C
 Snail	 Giraffe	 Duck
 Crab	 Lion	 Peacock
 Tortoise	 Deer	 Flamingo

Based on the table above, how are these animals grouped?

- (1) They are grouped according to their size.
- (2) They are grouped according to their outer covering.
- (3) They are grouped according to the place they live in.
- (4) They are grouped according to the number of legs they have.

2. Study the classification chart below carefully.

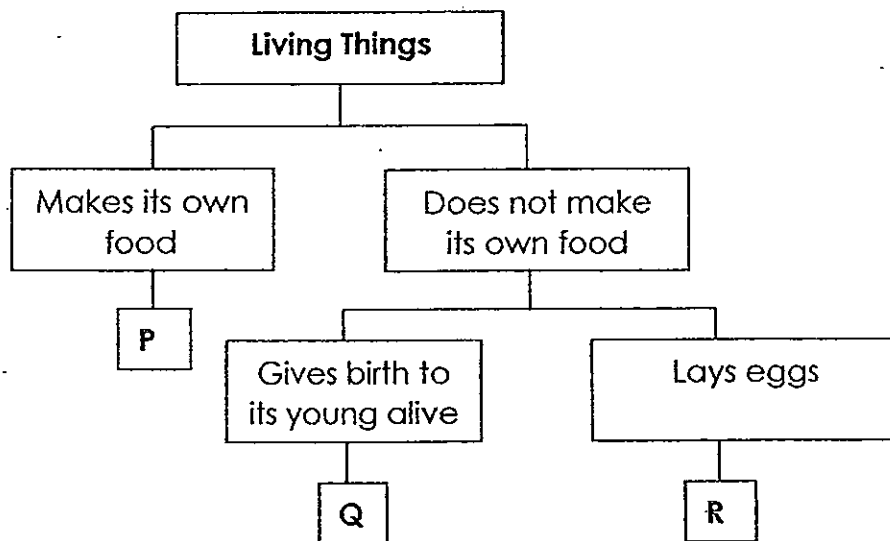

What can P, Q and R be?

	P	Q	R
(1)	Fern	Guppy	Tiger
(2)	Yeast	Seal	Platypus
(3)	Rose plant	Dolphin	Ostrich
(4)	Toadstool	Lizard	Clownfish

3. Study the flow chart below carefully.

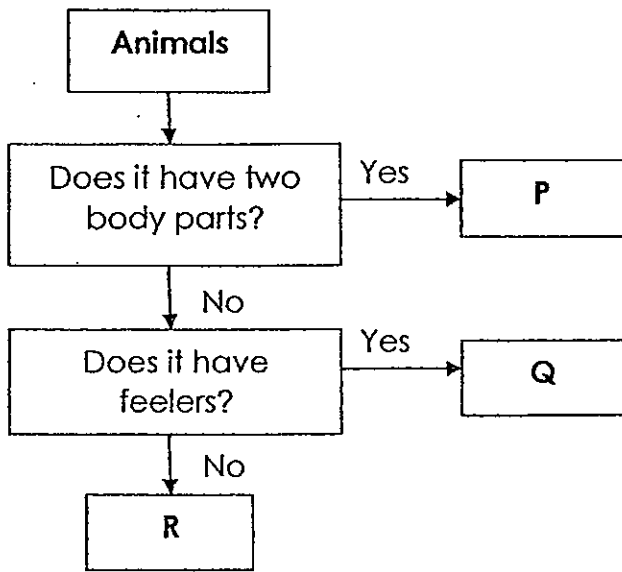

Classify the animals, X and Y, in the correct groups above.



Animal X

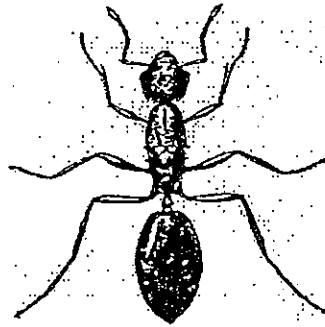

Animal Y

	Animal X	Animal Y
(1)	P	Q
(2)	P	R
(3)	Q	P
(4)	Q	R

4. Which of the following statements is true for all living things?

- (1) They live on land.
- (2) They can reproduce.
- (3) They can make food.
- (4) They look like their parents.

5. The graph below shows the number of worms in a tank over a period of four weeks.

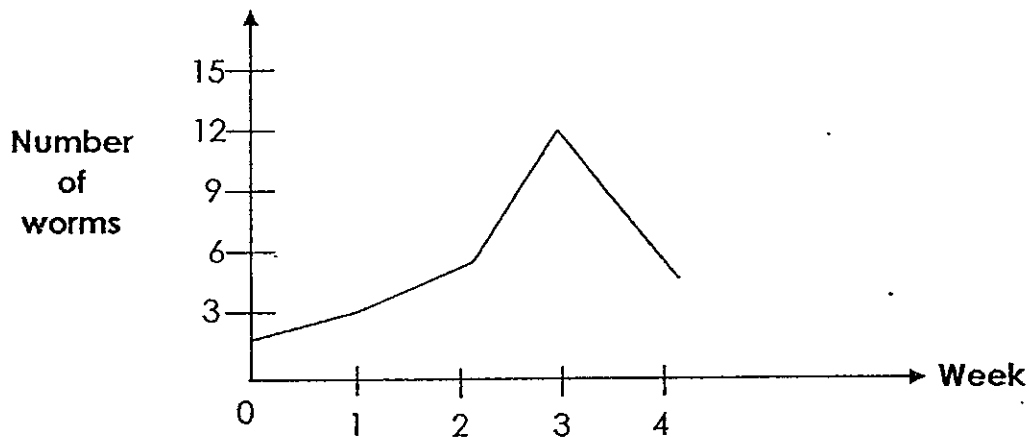

Based on the graph, which of the following statements is true?

- (1) Some worms were removed from the tank in Week 1.
- (2) Some worms were introduced into the tank in Week 3.
- (3) The number of worms increased over the first three weeks.
- (4) Sufficient water was given to the worms throughout the four weeks.

6. Study the diagram below carefully.

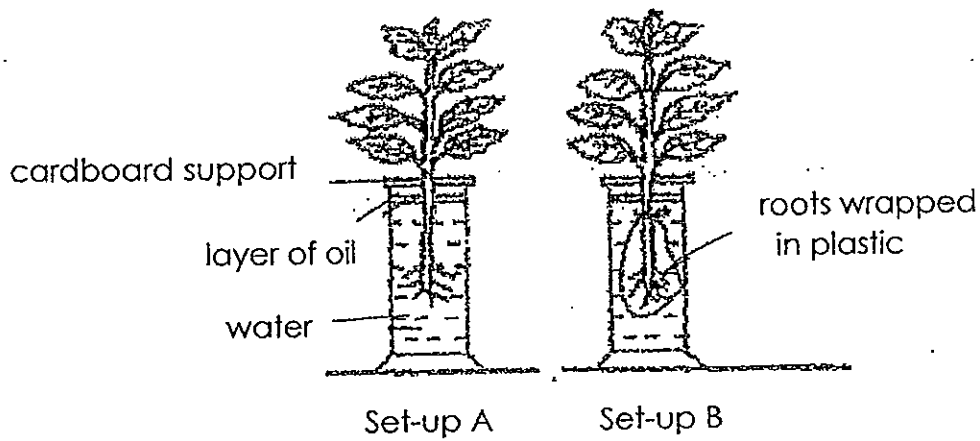

After seven days, the plant in Set-up A survived while the plant in Set-up B died.

Why did the plant in Set-up B die after seven days?

- (1) The roots could not make food.
- (2) The roots could not take in water to make food.
- (3) The roots could not hold the plant firmly to the ground.
- (4) The roots could not hold the plant upright to get sunlight.

7. Study the set-up below.

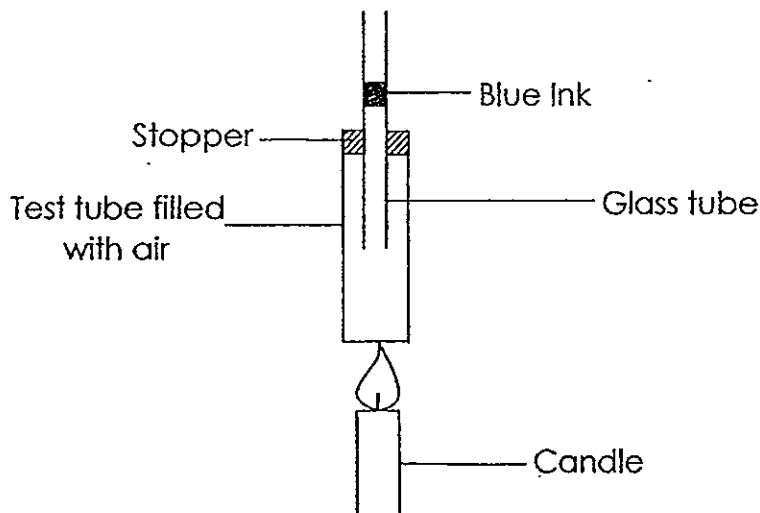

As the test tube was heated, Rena noticed that the drop of blue ink moved up the glass tube. What caused the drop of blue ink to move up the glass tube?

- (1) The drop of blue ink expanded and moved upwards.
- (2) The test tube expanded, pushing the drop of blue ink upwards.
- (3) The glass tube expanded, pushing the drop of blue ink upwards.
- (4) The air in the test tube expanded, pushing the drop of blue ink upwards.

8. Study the table below carefully.

Group X	Group Y
Iron rod Nickel coin Steel spoon	Ceramic tile Wooden table Aluminium sheet

Which is the most suitable heading for the objects in the table above?

	Group X	Group Y
(1)	Flexible	Stiff
(2)	Magnetic	Non-magnetic
(3)	Translucent	Opaque
(4)	Poor conductors of heat	Good conductors of heat

9. Study the flow chart below.

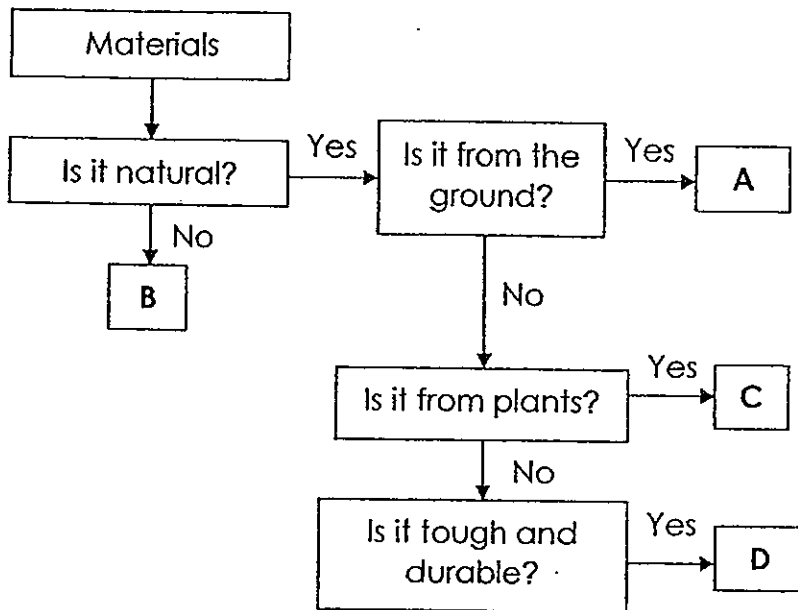

Which of the following correctly represents A, B, C and D?

	A	B	C	D
(1)	Glass	Leather	Cotton	Iron
(2)	Wood	Plastic	Leather	Cotton
(3)	Iron	Plastic	Wood	Leather
(4)	Leather	Glass	Iron	Plastic



10. The four pans shown below are of the same size and thickness.

Which of the pans would be most ideal for cooking food quickly and safely?

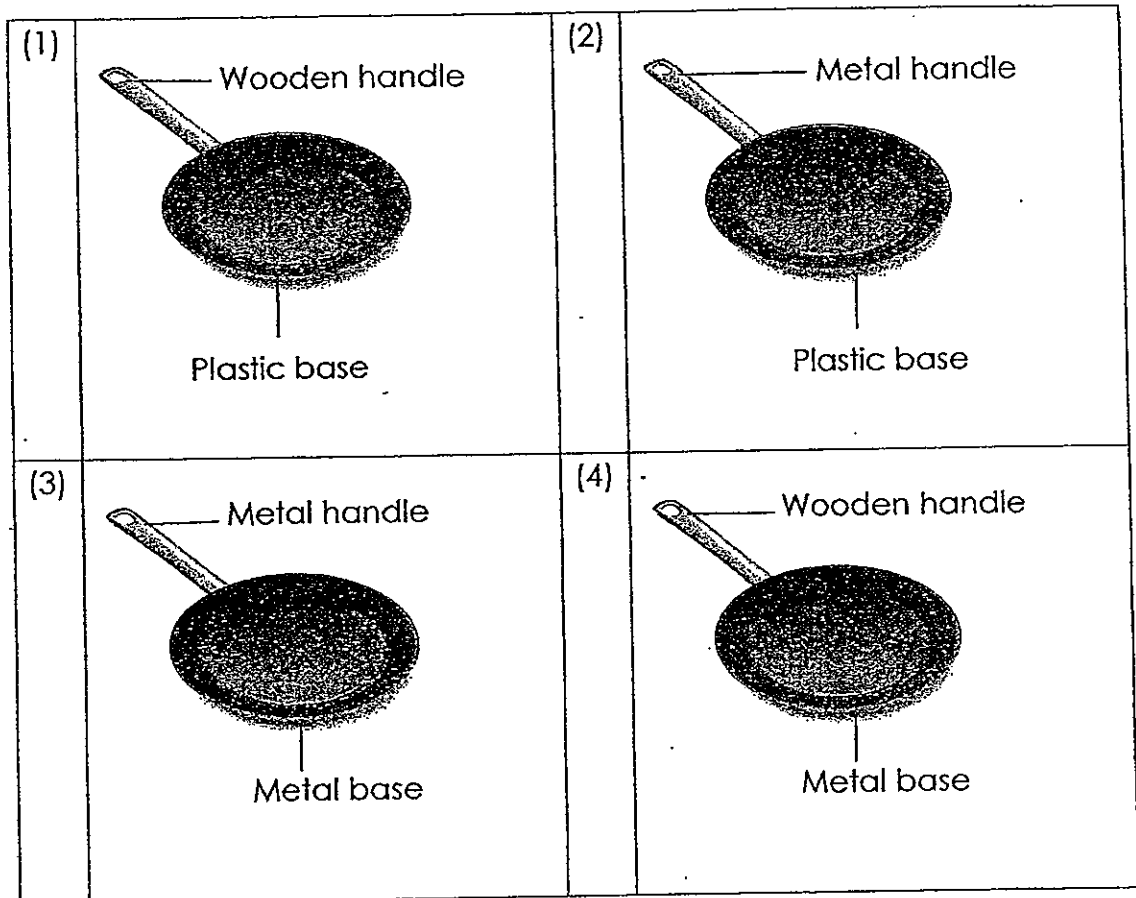

11. The diagram below shows three beakers of water, A, B and C, and two similar metal chains immersed in the water. The arrows in the diagram below indicate how heat travels through the chains just after they are immersed into the three beakers of water, A, B and C.

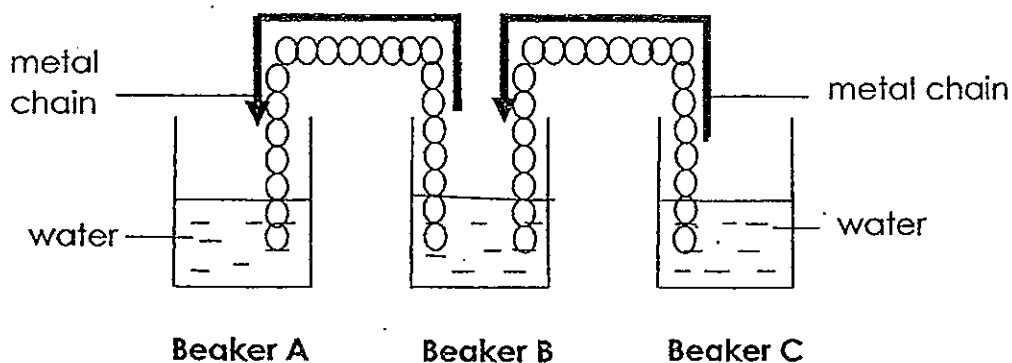

Which of the following most likely shows the temperatures of the water in the three beakers, A, B and C, when the chains were just put in?

	Temperature of water in Beaker A (°C)	Temperature of water in Beaker B (°C)	Temperature of water in Beaker C (°C)
(1)	90	30	60
(2)	60	30	90
(3)	90	60	30
(4)	30	60	90

12. Which of the following objects gives out light of its own?

- (1) Star
- (2) Moon
- (3) Battery
- (4) Diamond

13. Sharon placed three blocks, made of different materials, in the sun as shown in the set-up below. After 45 minutes, she measured the surface temperature of each block.

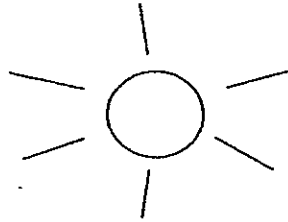

Glass block



Steel block



Styrofoam block



What is the purpose of her experiment?

- (1) She wants to find out which material expands the fastest.
- (2) She wants to find out how heat travels through the blocks.
- (3) She wants to find out which material is a good conductor of heat.
- (4) She wants to find out which material will melt in the presence of heat.

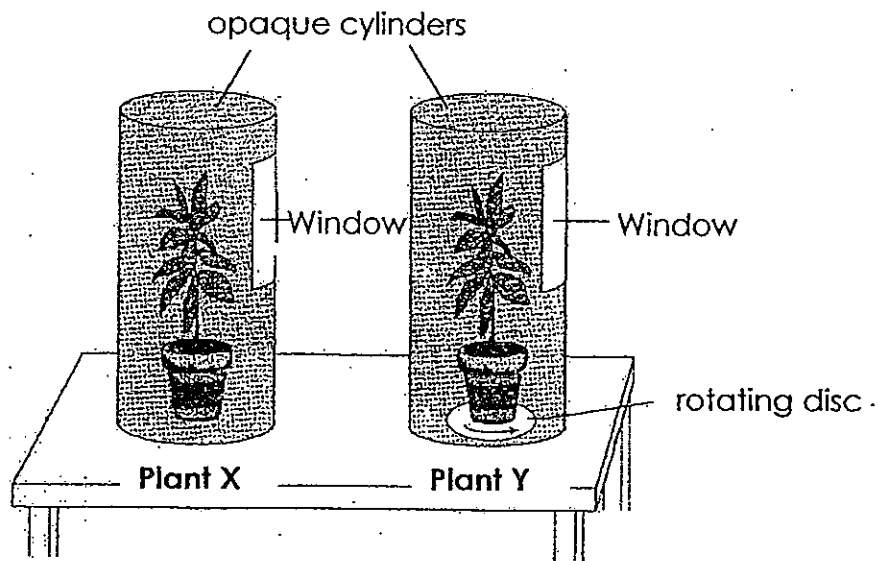
14. The diagram below shows two identical plants placed in opaque cylinders. There is a window to let light in. Only plant Y is rotated continuously on a disc.

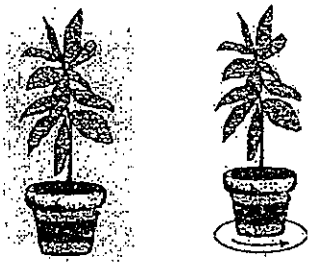
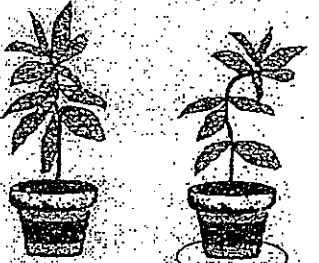

Which of the following shows how the plants will look like when the cylinders are removed two weeks later?

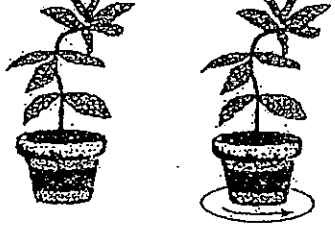
(1)	 <p>Plant X      Plant Y</p>	(2)	 <p>Plant X      Plant Y</p>
(3)	 <p>Plant X      Plant Y</p>	(4)	 <p>Plant X      Plant Y</p>

15. The picture shows a plant with a small ring-like layer with food-carrying tubes carefully removed from the outer part of the stem at part P, leaving the water-carrying tubes behind.

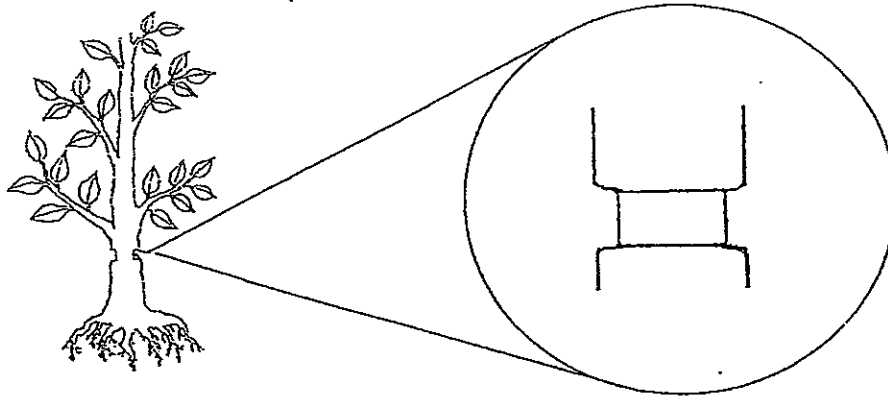

enlarged view of part P

Which diagram shows the likely change on the stem at part P after a period of time?

(1)		(2)	
(3)		(4)	

16. Zen carried out an experiment. He took four ants of the same kind and put each ant into four identical containers, A, B, C and D, as shown below. He left all the containers in a room at room temperature.

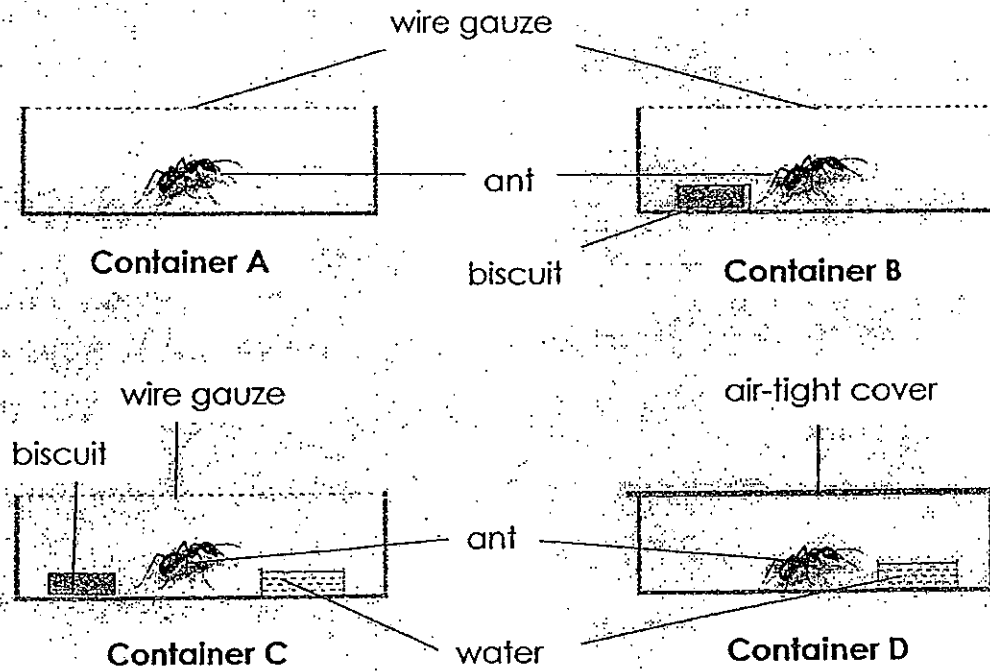

Zen recorded how long the ant in each container survived.

Which order shows how long the ant survives from the least number of days to the most number of days?

- (1) A, B, D, C
- (2) A, D, B, C
- (3) D, B, A, C
- (4) D, A, B, C

17. Justin and Roland conducted an experiment to see which material can keep the ice cubes in the solid state for a longer period of time. They put their ice cubes in different containers of the same size before they started the experiment.

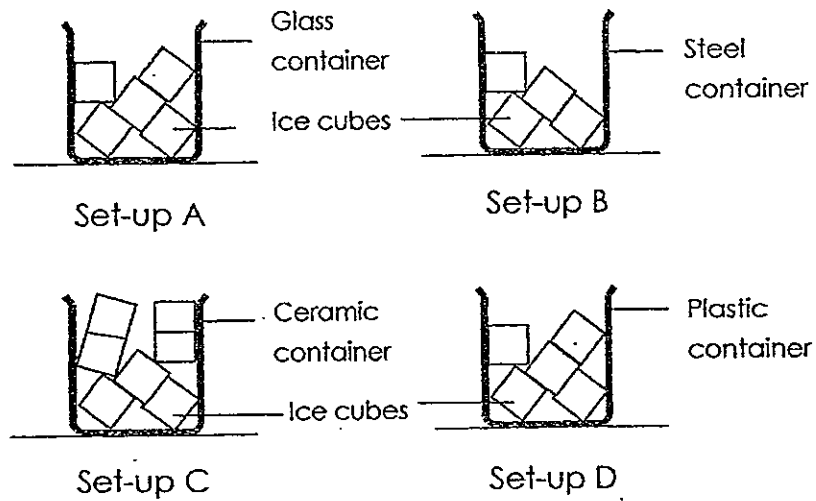

Which two set-ups should they choose for a fair test?

- (1) Set-ups A and B
- (2) Set-ups A and D
- (3) Set-ups B and C
- (4) Set-ups C and D

18. Simon was given a metal ball and a metal ring as shown below. He was not able to put the metal ball through the ring.

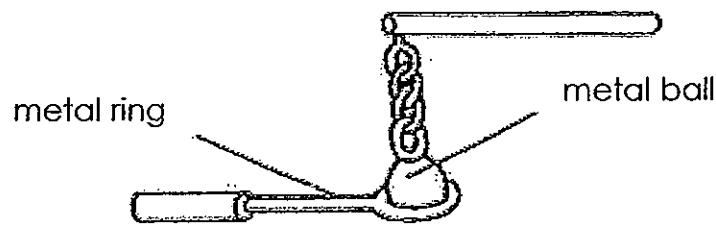

What should he do so that the metal ball can pass through the metal ring?

- (1) He should heat the metal ball.
  - (2) He should heat the metal ring.
  - (3) He should heat both the metal ring and the metal ball.
  - (4) He should cool both the metal ring and the metal ball.
19. Valerie placed a metal spoon on an ice cube as shown below.

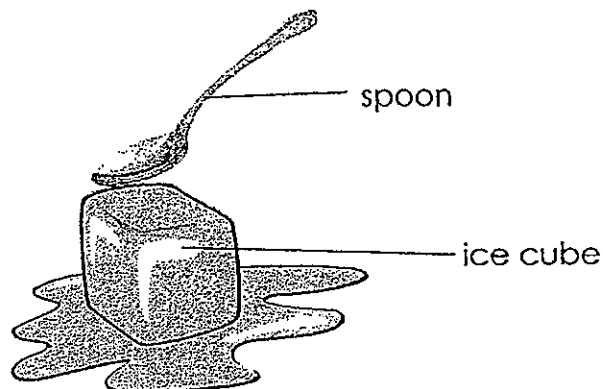

After a few minutes, she touched the spoon and said that it was colder than before.

Why did the spoon become colder?

- (1) The ice cube melted.
- (2) The ice cube lost heat to the spoon.
- (3) The spoon lost heat to the ice cube.
- (4) The spoon gained heat from the ice cube.



20. Paul poured 80 ml of water into Beaker Y and 40 ml of water into Beaker Z as shown in the diagram below. The temperature of the water in both beakers was the same.

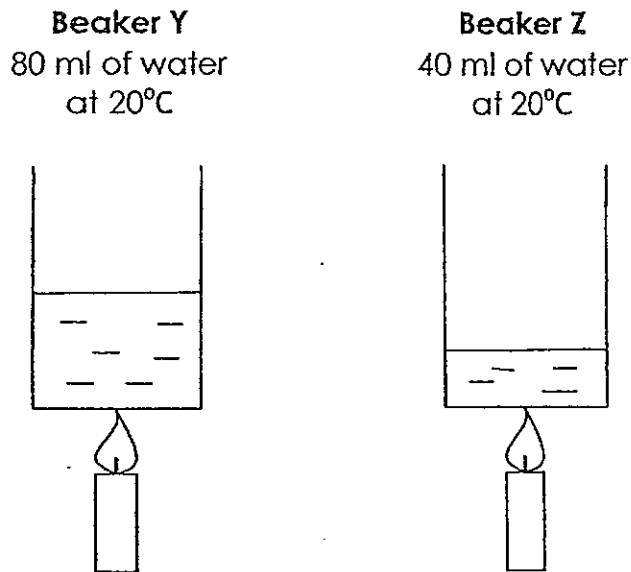

He heated each beaker of water with an identical candle each for three minutes. Then he recorded the temperature of the water.

Which of the following are possible temperatures of the water recorded for both beakers?

	Beaker Y	Beaker Z
(1)	20°C	20°C
(2)	50°C	70°C
(3)	70°C	50°C
(4)	70°C	70°C

21. The diagram below shows the top view of a part of a maze. Three mirrors are placed at the positions shown, with four children each standing at different positions.

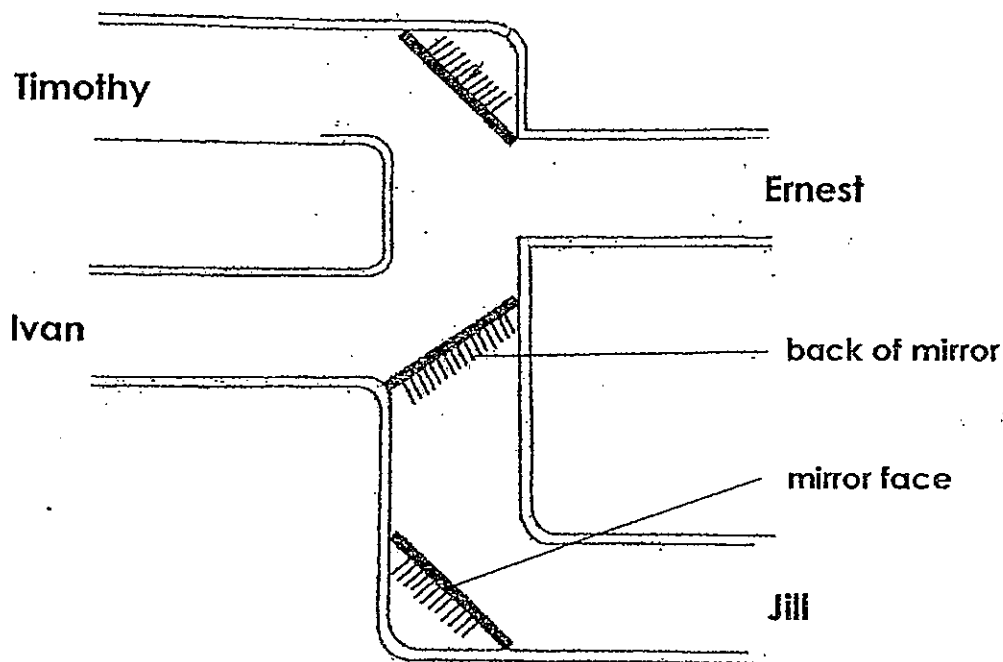

Which two pupils will be able to see each other from where they are standing?

- (1) Jill and Ivan
- (2) Jill and Ernest
- (3) Timothy and Ivan
- (4) Timothy and Ernest

22. A pole was left standing upright in the Sun from 6 a.m. to 6 p.m. The length of its shadow was measured and plotted on a graph.

Which of the following graphs below best represents the length of shadow over time?

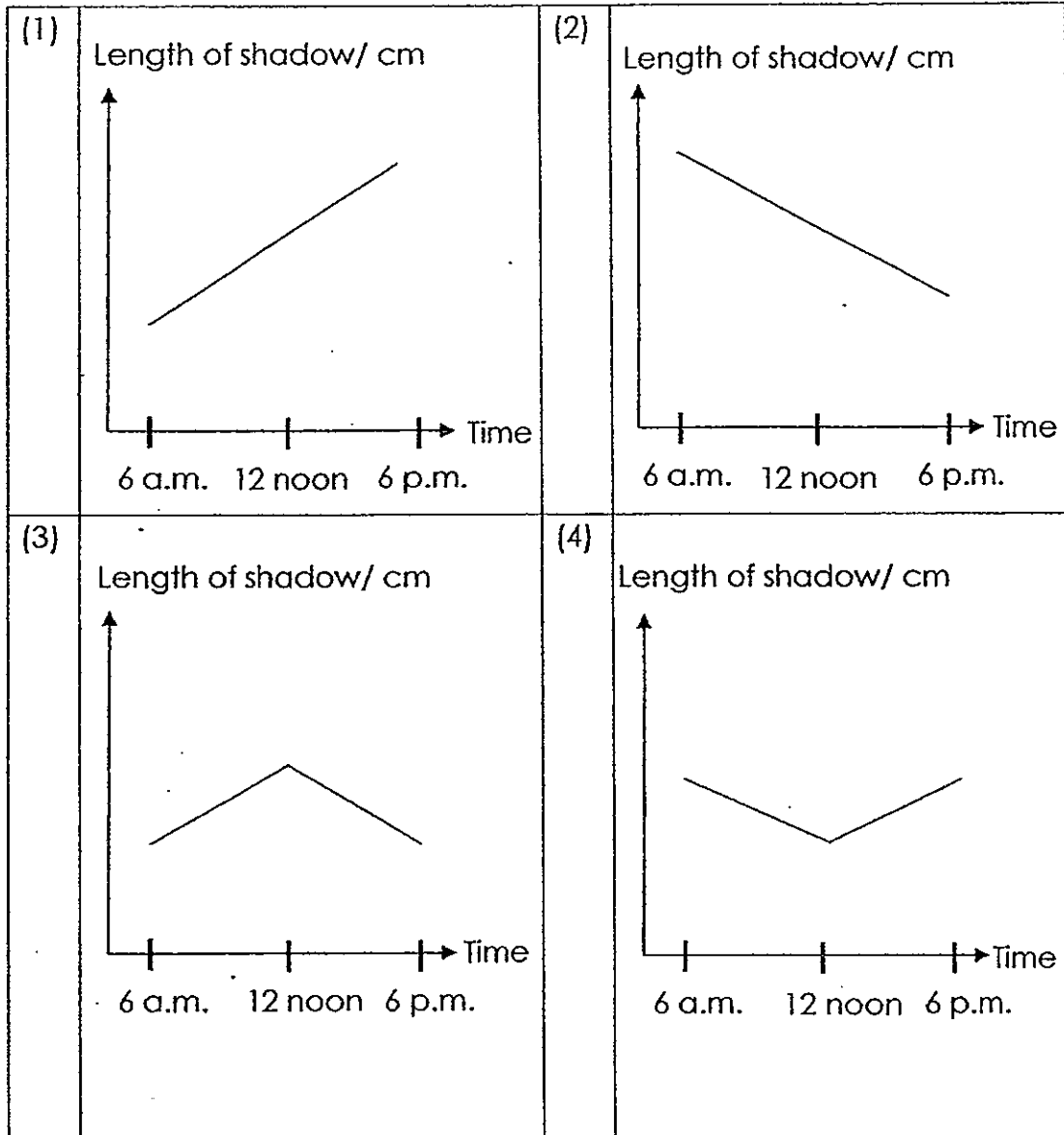

23. Sharifah was given the following four pieces of cardboard. The shapes of the cardboard are shown in the diagram below.

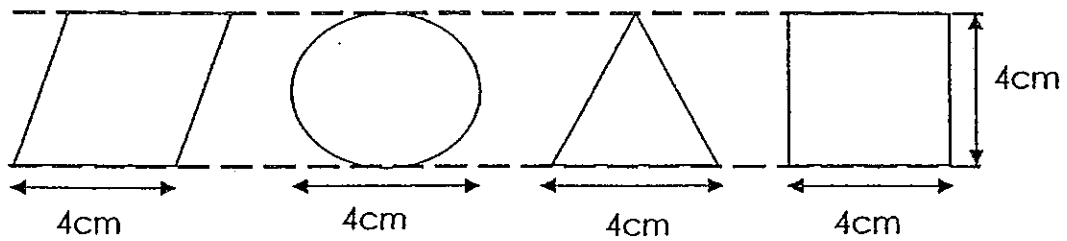

She tried to place all the pieces of cardboard together between a torch and a screen at the same time.



What is the maximum number of pieces of cardboard that she could use at any one time so as to form the following shadow?

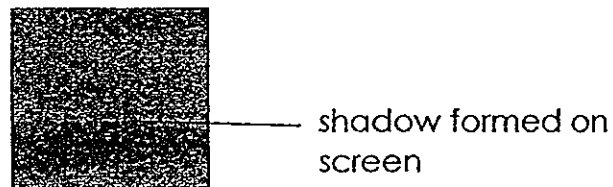

- (1) 1
- (2) 2
- (3) 3
- (4) 4

24. Three glasses are stuck together as shown below.

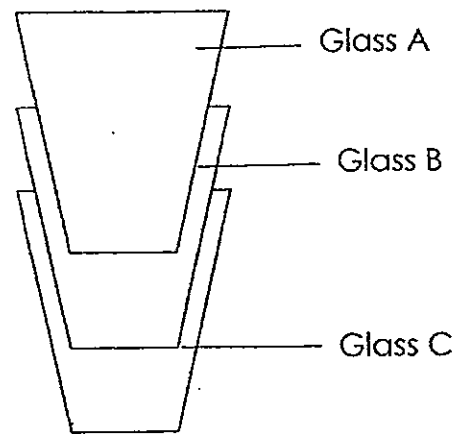

Which of the following is the quickest method to separate the glasses?

- (1) Immerse the stack of glasses in a basin of hot water.
- (2) Immerse the stack of glasses in a basin of cold water.
- (3) Pour hot water in glass A and put glass C in cold water.
- (4) Pour cold water in glass A and put glass C in hot water.

25. Ryan wanted to find out how clear the water was in ponds A, B, C and D. He collected an equal amount of water from each pond. He set up his experiment as shown below.

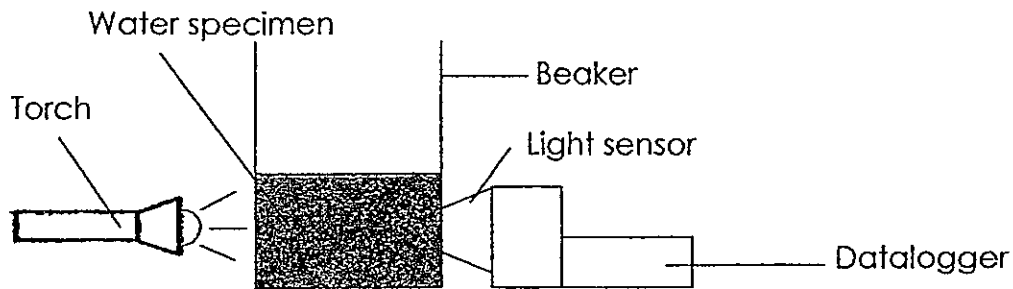

To measure the clarity of the water, Ryan shines the torch through the water in the beaker on one side. He places the datalogger and light sensor on the opposite side of the beaker. The datalogger records the amount of light passing through the water.

The results are shown in the table below.

	Pond A	Pond B	Pond C	Pond D
Amount of light (unit)	1400	2000	800	300

From the results above, which pond would submerged aquatic plants grow best in?

- (1) A
- (2) B
- (3) C
- (4) D

26. Jessica set up the experiment shown below. The insulated cup minimises heat loss and heat gain from the surroundings.

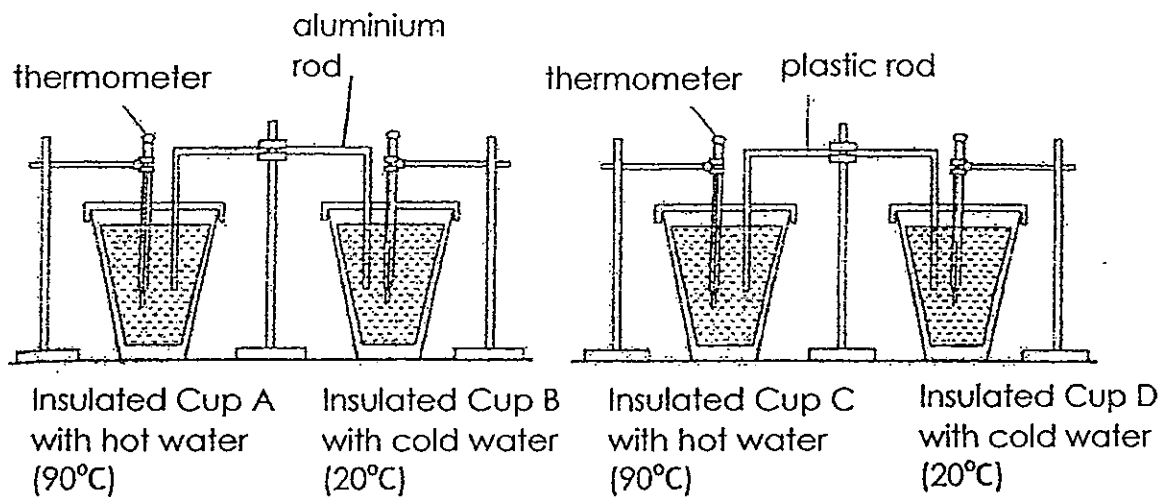

Jessica left the apparatus in the open. She measured the temperature of the water after three minutes.

Which of the following correctly describes what she will observe after three minutes?

- (1) The temperature of the water in Cups B and D will be the same.
- (2) The temperature of the water in Cups A and C will be the same.
- (3) The temperature of the water in Cup A will be higher than the temperature of water in Cup C.
- (4) The temperature of the water in Cup D will be lower than the temperature of water in Cup B.

27. Which of the following objects requires the use of magnets?

(1)



Microphone

(2)

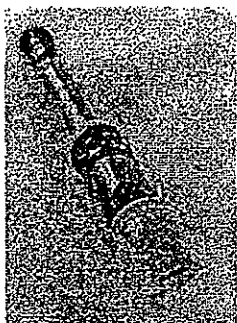

Recorder

(3)

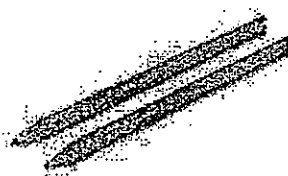

Pencil

(4)

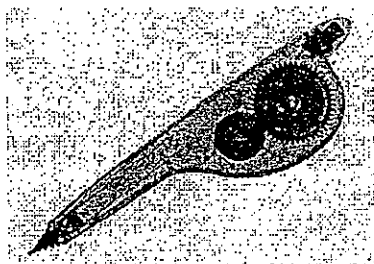

Correction tape



28. The diagram below shows a magnet wrapped with a piece of copper foil. The magnet was then placed into a trough of iron filings.

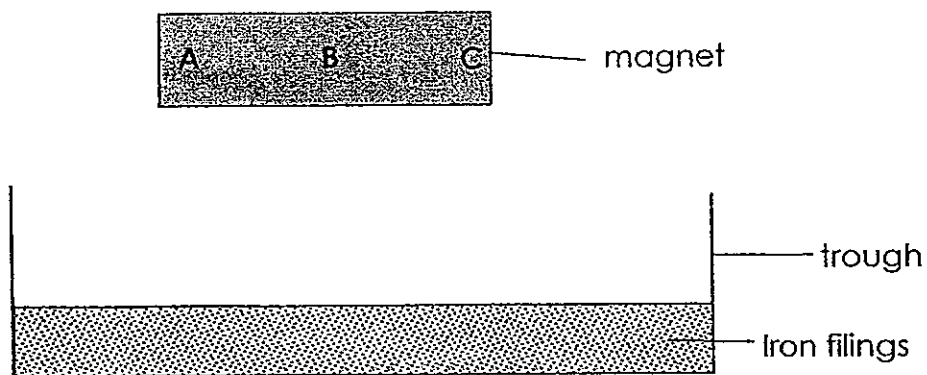

Which of the following shows the amount of iron filings most likely to be attracted to the different parts of the magnet, A, B and C, when it was removed from the trough?

	Amount of iron filings on the magnet (grams)		
	A	B	C
(1)	0	0	0
(2)	3.2	3.2	3.2
(3)	3.8	0.7	0.7
(4)	3.2	0.7	3.2

29. The diagram below shows how five bar magnets are placed together and the letters represent the poles of four of the magnets.

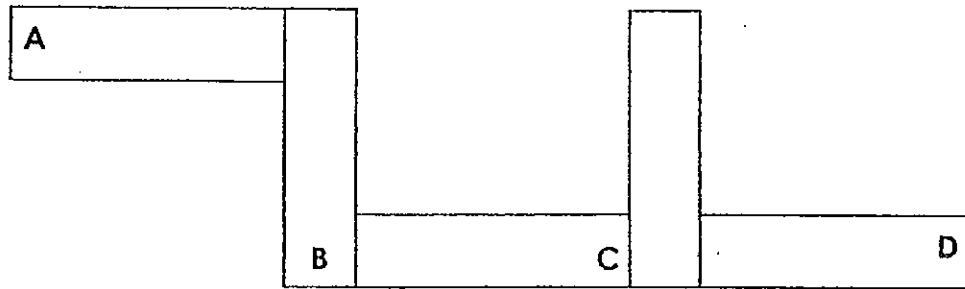

Which of the following most likely represents the poles of the four magnets correctly?

	Poles of the magnets			
	A	B	C	D
(1)	South	South	North	South
(2)	North	South	South	North
(3)	South	North	South	South
(4)	North	South	North	North

30. Devi set up three bar magnets and two compasses and brought **Compass P** towards pole **A** of a bar magnet as shown in the diagram below.

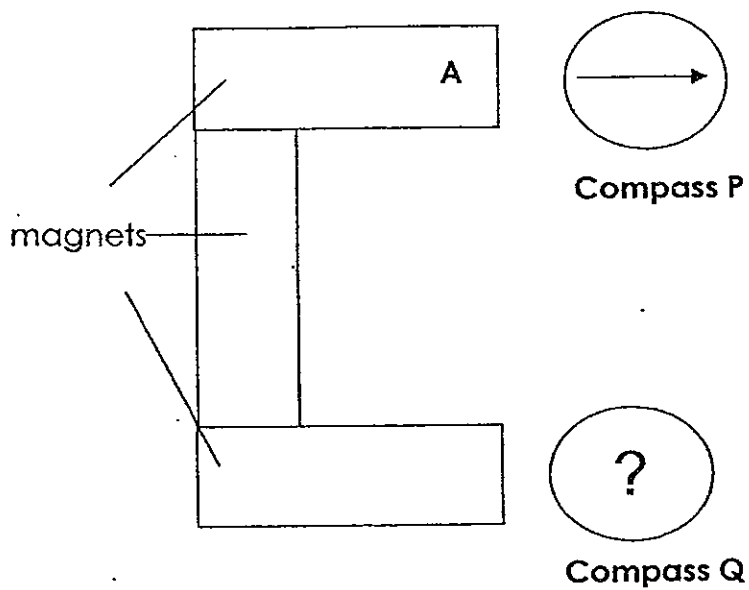

Which of the following correctly represents the direction compass Q will point to?

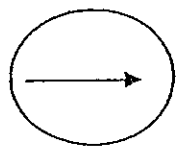
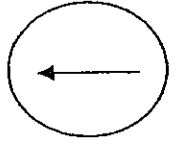
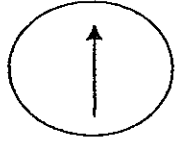
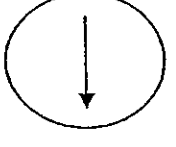
(1)		(2)	
(3)		(4)	



## PRIMARY 4 MID-YEAR EXAMINATION 2012

Name \_\_\_\_\_ (      ) Date: 14 May 2012

Class : Primary 4 (      )

Time: 8.00 a.m. - 9.30 a.m.

Duration : 1 hour 30 minutes

Parent's Signature : \_\_\_\_\_

Marks: \_\_\_\_\_ / 40

## **SCIENCE BOOKLET B**

### INSTRUCTIONS TO CANDIDATES

Write your name, class and register number.

Do not turn over this page until you are told to do so.

Follow all instructions carefully.

Answer all questions.

Section B (40 marks)

Write your answers in the space provided.

31. Study the pictures below carefully.

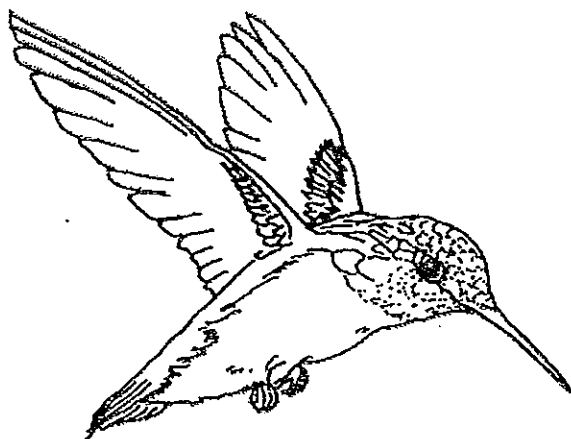

Bird

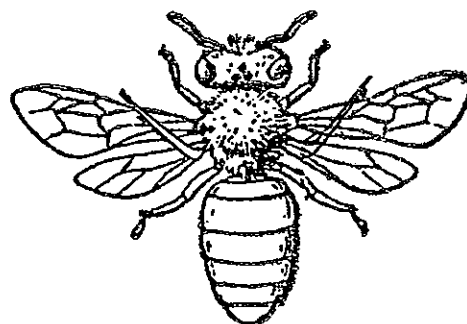

Bee

a) Based on the pictures above, state a similarity between the bee and the bird. (1m)

---

---

b) Based on the pictures above, state a difference between the bee and the bird. (1m)

---

---

32. Study the flow chart below carefully.

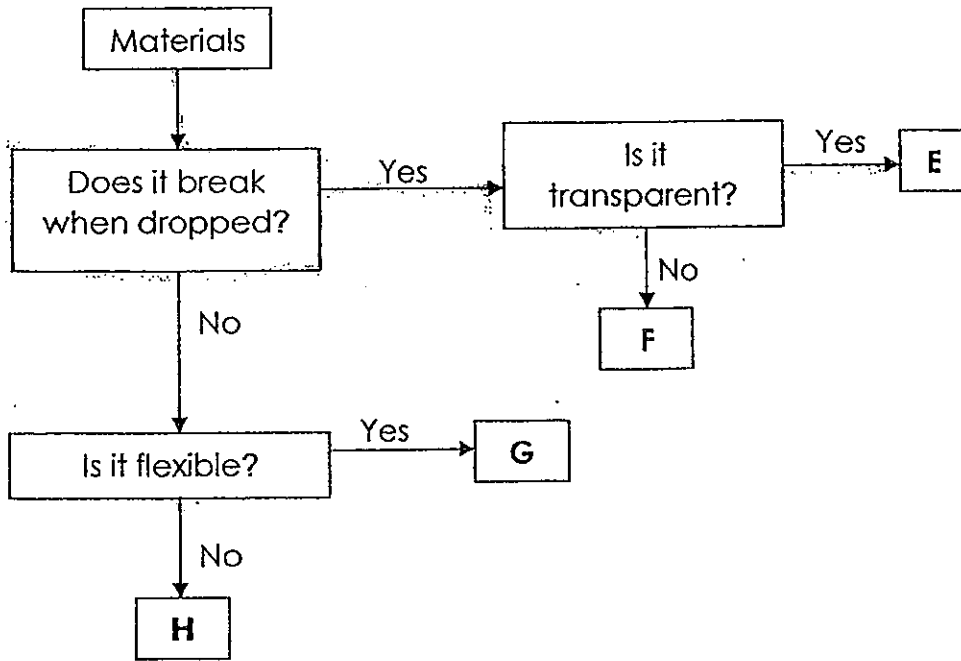

a) What is the difference between Materials E and F? (1m)

---

---

b) How are Materials G and H similar? (1m)

---

---

c) Describe Material G based on the flow chart above. (2m)

---

---

33. Zoe ate a hamburger for lunch. The graph below shows the amount of undigested hamburger as it leaves that part of the digestive system.

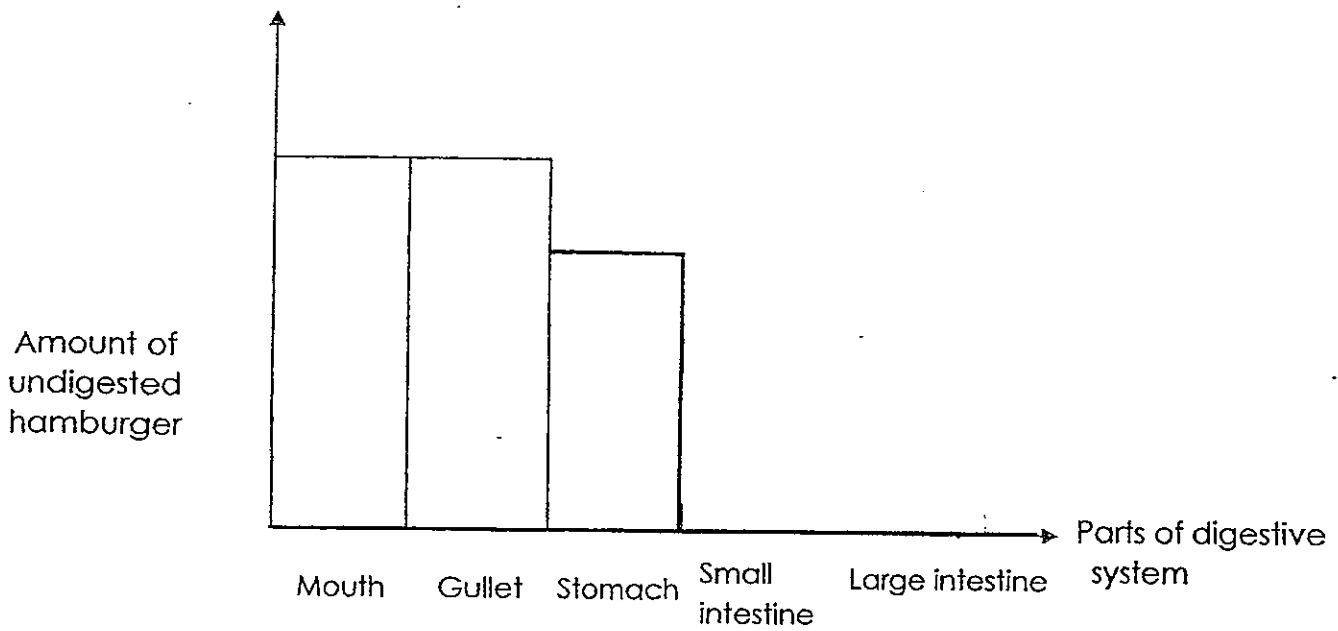

a) Based on the graph above, at which part of the digestive system would the greatest amount of food be digested? (1m)

b) Complete the graph above to show the amount of undigested food as it leaves the large intestine. (1m)

c) The graph below shows the digested food in the digestive system. Complete the graph to show the amount of digested food in the stomach and small intestine (2m)

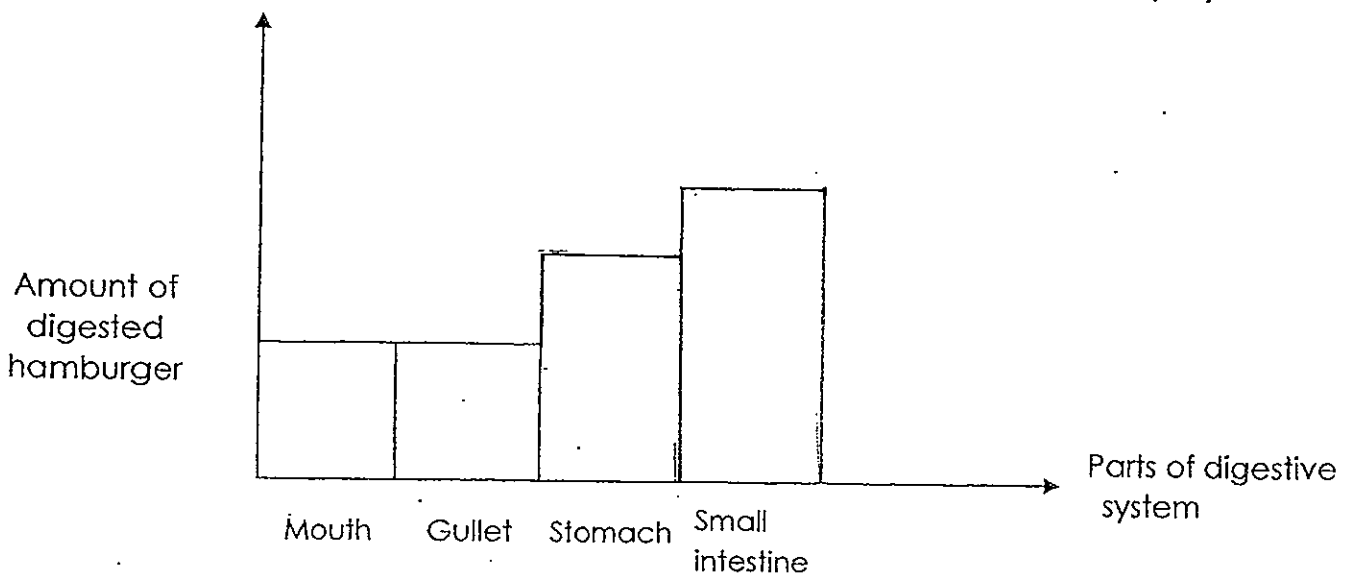

143

34. Kenny used four rods, A, B, C and D, of identical thickness and lengths for an experiment. The rods were made of different materials. He put a ring of wax around each of them and heated each rod at End Y. He recorded the time taken for each ring of wax to melt and drop off.

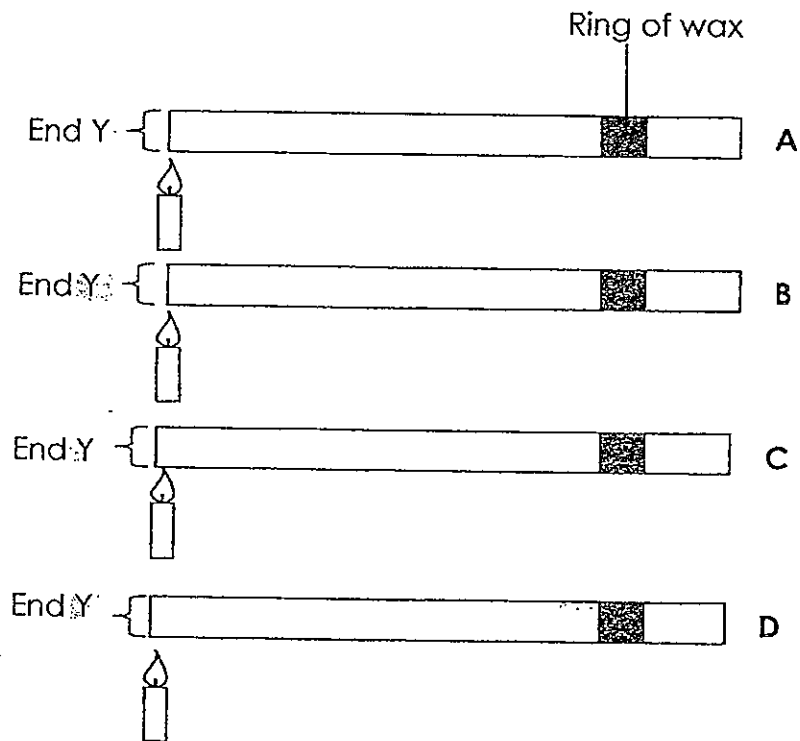

Rod	Time taken for wax to melt and drop off (minutes)
A	12
B	24
C	6
D	36



a) Circle the variable which should be kept the same and the variable which should be changed to ensure a fair test. (1m)

Variable		
Material of rod	Kept the same	Changed
Distance between the candle flame and the ring of wax	Kept the same	Changed

b) Based on the results given, which rod is the best conductor of heat? Explain your answer. (2m)

---

---

35. Two similar metal rods, Rod A and Rod B, are made of different materials and joined together as shown below. Two thumbtacks R and S are stuck to Rod A and Rod B using wax.

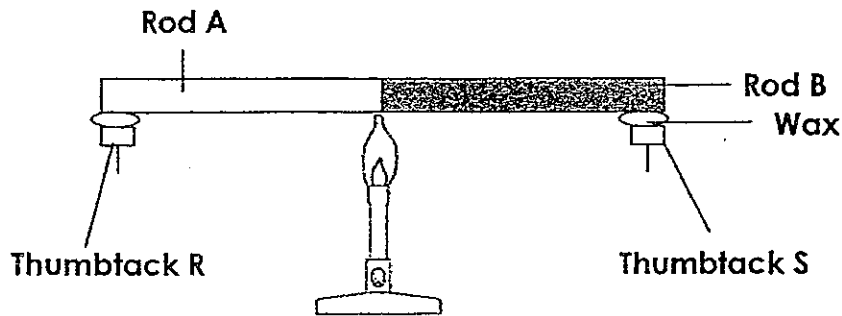

After heating for some time, Thumbtack R dropped first; followed by Thumbtack S a minute later.

- a) Explain why the wax melted and the thumbtacks dropped off. (1m)

---

---

- b) Explain why Thumbtack R dropped off first. (1m)

---

---

- c) Suggest a change to the set-up so that the thumbtacks can drop at about the same time. (Do not add or remove any object in the above set-up) (1m)

---

---

36. Alvin conducted an experiment to find out how the amount of light reflected by Materials P and Q is affected by the distance between the material and the light source. He set up the experiment as shown below.

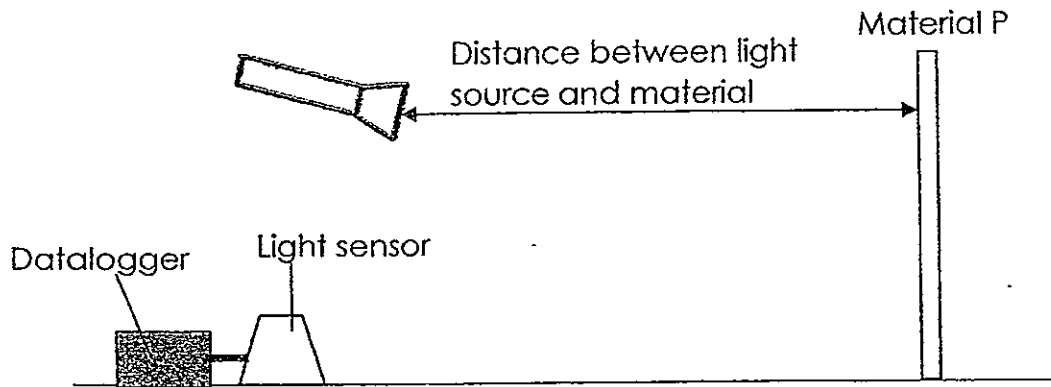

He placed the material at different distances away from the light source and he used a light sensor to determine the amount of light that was reflected.

He repeated the experiment with Material Q. He recorded the results and plotted the results in the graph below.

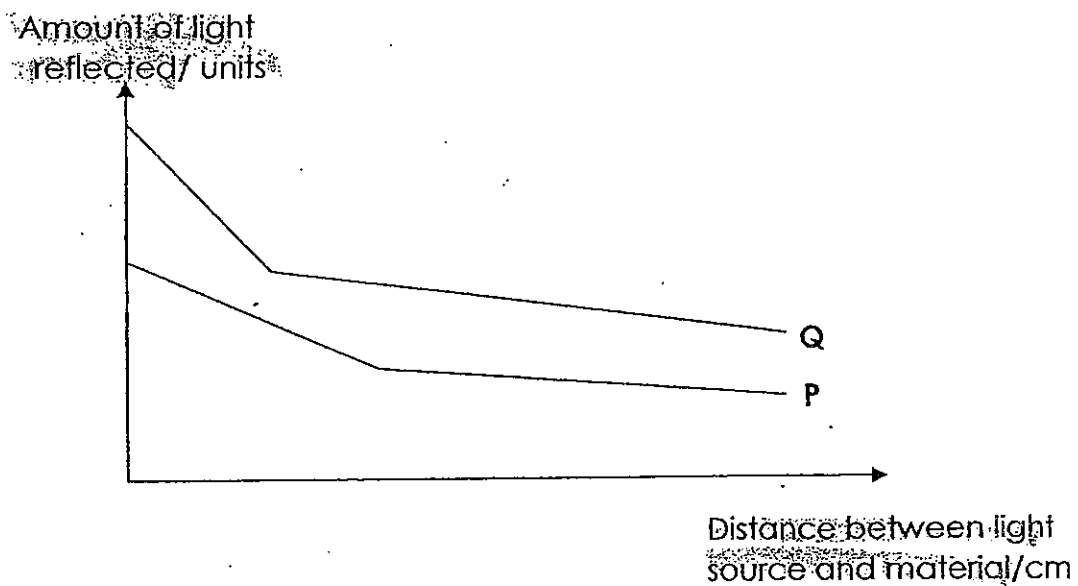

a) What is the relationship between the amount of light reflected and the distance between the light source and material? (1m)

---

---

b) Based on the results of the experiment, which material, P or Q, would be more suitable for making safety vests for cyclists who cycle at night? (1m)

---

---

c) Explain your answer in (b) (1m)

---

---

37. In the diagram below, Ben was able to see the cone from the mirror when he was standing at the position shown below.

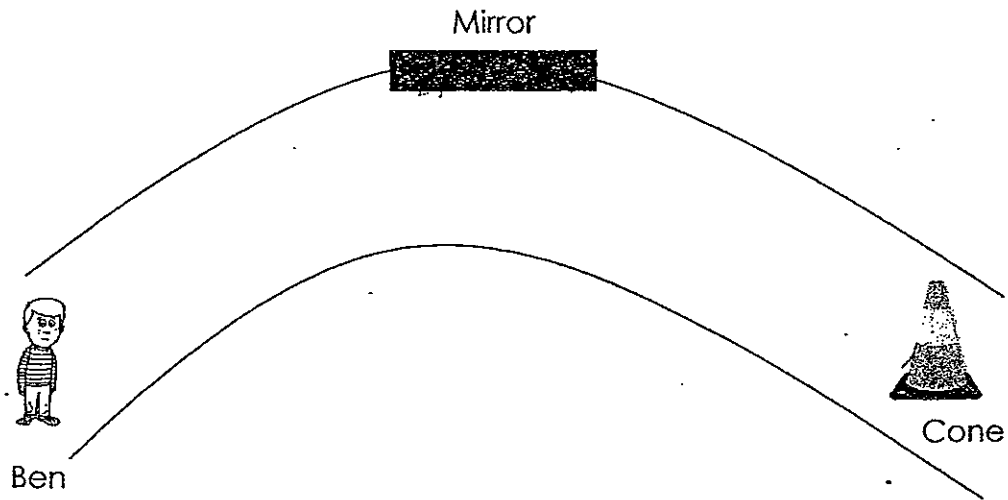

a) In the diagram above, draw the path of light showing how Ben was able to see the cone. (1m)

b) List two properties of light that enabled Ben to see the cone. (2m)

38. Mrs Lee used a torch to shine on an opaque object X from Positions Y and Z.

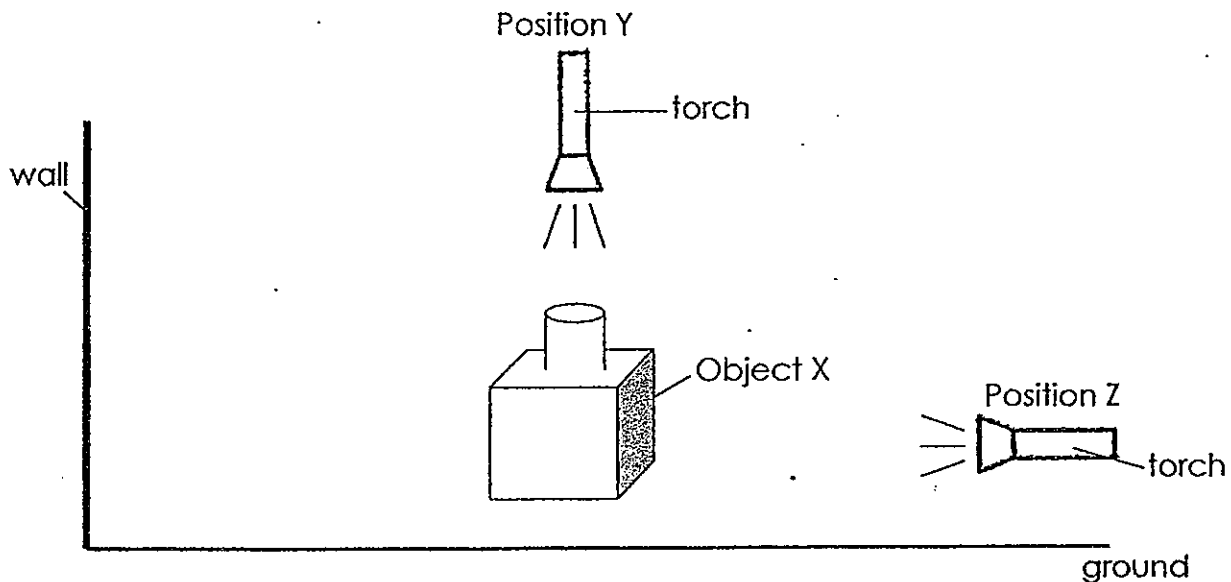

a) Draw the shadow

i) cast on the ground when she shone the torch from Position Y. (1m)

ii) cast on the wall when she shone the torch from Position Z. (1m)

i) Shadow cast on the ground	ii) Shadow cast on the wall

39. Matthew has three similar cups which are made of different materials, A, B and C. He wants to investigate which material is most suitable for keeping his drink cold. He places three ice cubes in each cup in an enclosed room. The results after ten minutes are shown in the diagram below.

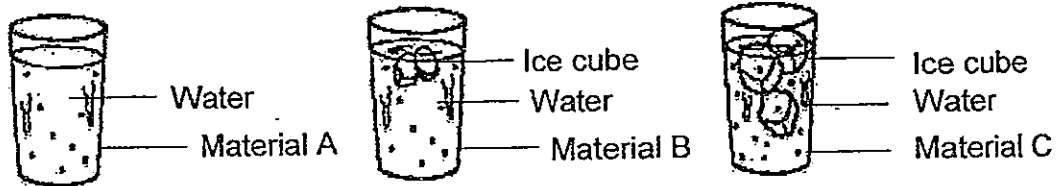

a) Which material, A, B, or C, is most suitable for keeping his drink cold for the longest time? (1m)

---

b) Explain your answer in (a). (1m)

---

---

40. Diagram A shows how two different Rings X and Y were positioned on a retort stand. Y was held by a clamp in position. Diagram B shows what happened to the rings when another Ring Z was added to the set-up as shown below.

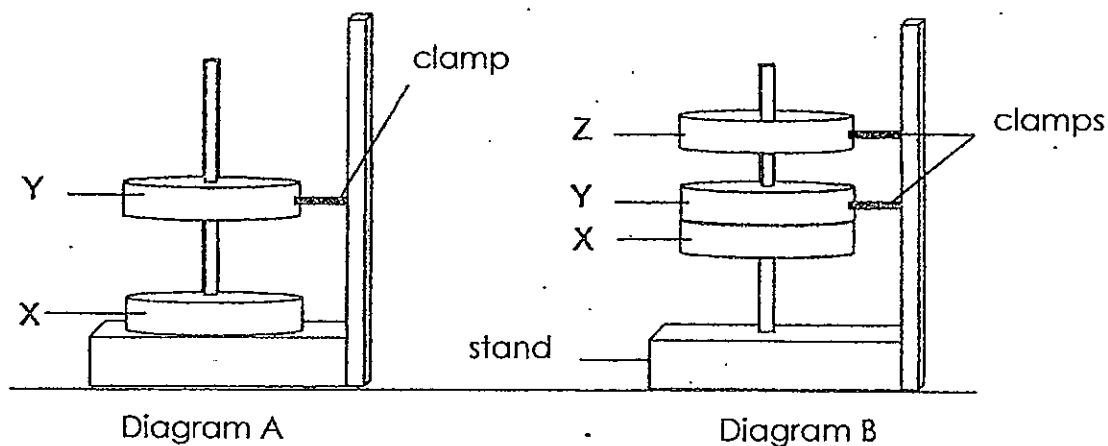

a) Is Ring Y made of magnetic or non-magnetic material? (1m)

---

b) Explain your answer in (a). (1m)

---



---

c) Name one possible material Ring Z can be made of. (1m)

---



---



41. Mark made an electromagnet as shown below.

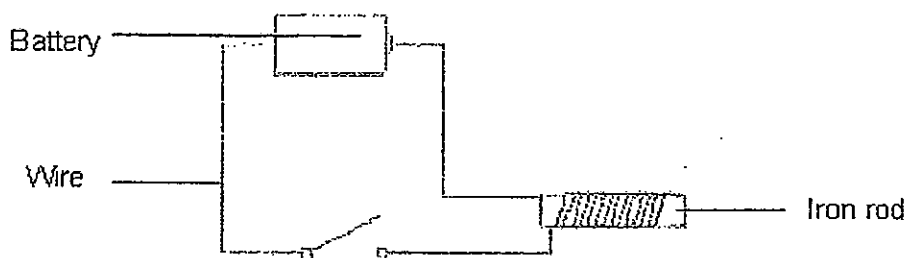

He varied the number of coils of wire around the iron rod and recorded the number of paper clips picked up by the electromagnet.

Number of coils of wire around the iron rod	Number of paper clips picked up
10	12
15	14
20	16
25	18

a) What is the relationship between the number of coils of wire around the iron rod and the number of paper clips picked up? (1m)

---

---

b) Other than increasing the number of coils of wire around the iron rod, write down another way to increase the strength of the electromagnet. (1m)

---

---

42. A steel bar, AB, was magnetised using the "stroke" method as shown in Diagram 1 below. Diagram 2 shows the magnetic poles of AB after it was magnetised.

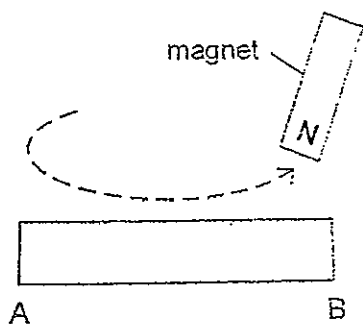

Diagram 1

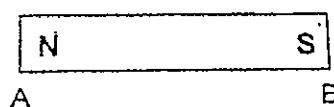

Diagram 2

Another steel bar CD was magnetised using two magnets as shown in Diagram 3 below.

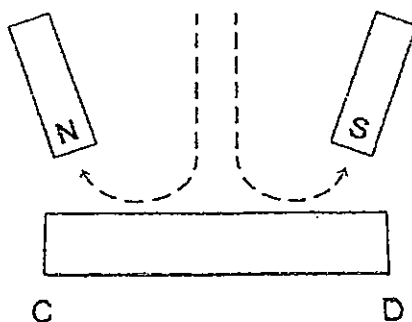

Diagram 3

a) State what the magnetic poles of the steel bar CD would be at C and D. (1m)

(i) At C: \_\_\_\_\_

(ii) At D: \_\_\_\_\_

b) Daryl wanted to magnetise a steel bar XY using the North poles of two magnets as shown in Diagram 4 below.

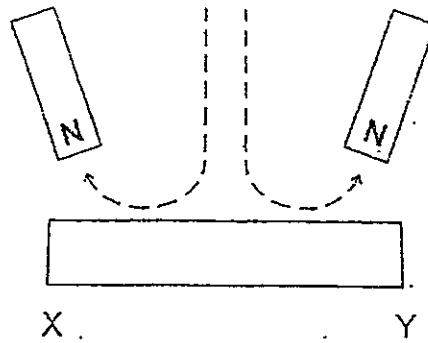

Diagram 4

Give a reason why steel bar XY cannot be magnetised by Daryl's method. (1m)

---

---

43. The diagram below shows two metal bars, Y and Z, and their ends labelled A, B, C and D. Metal bar Z is twice as long as Metal bar Y. End C is able to attract both ends A and B.



**Metal bar Y**



**Metal bar Z**

a) Based on the information above, put a tick (✓) in the correct boxes.

(2m)

		True	False	Not Possible To Tell
(i)	Both Y and Z are magnets.			
(ii)	Z is made of magnetic material.			
(iii)	Y is a weak magnet.			
(iv)	Z is longer than Y so it has a stronger magnetic force.			

b) A piece of metal bar, X, is brought near Magnet W.

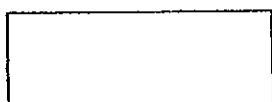

**Metal bar X**



**Magnet W**

What must you do to find out if Metal X is a magnet?

(2m)

---



---

44. Four magnets, **A**, **B**, **C** and **D**, were tested for their magnetic strength. A nail was slowly pushed towards each magnet until it was attracted by the magnet as shown in the diagram below. The distance from which the magnet is able to attract the nail is called the pulling distance.

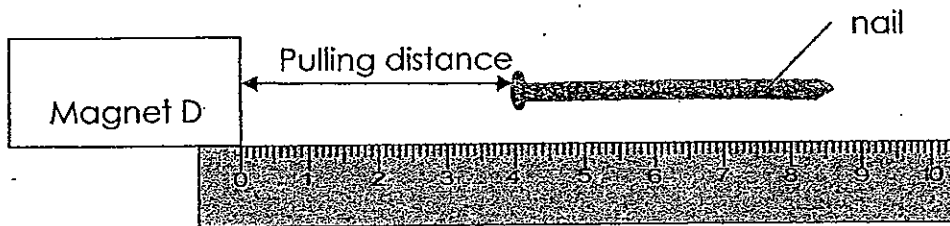

a) The table below shows the pulling distance of the four magnets. Fill in the pulling distance of magnet D based on the picture above.

(1m)

Magnet	Pulling distance (cm)
A	9
B	2
C	6
D	

b) In the boxes below, arrange the magnets, A, B, C and D, according to their strength, from the strongest to the weakest. (1m)

--	--	--	--

Strongest  $\longrightarrow$  Weakest

c) Explain your answer in (b). (2m)

---



---

End of paper



# ANSWER SHEET

EXAM PAPER 2012

SCHOOL : TAO NAN  
SUBJECT : PRIMARY 4 SCIENCE

TERM : SA1

Q1	Q2	Q3	Q4	Q5	Q6	Q7	Q8	Q9	Q10	Q11	Q12	Q13	Q14	Q15	Q16	Q17
2	3	1	2	3	2	4	2	3	4	4	1	3	3	3	4	2

Q18	Q19	Q20	Q21	Q22	Q23	Q24	Q25	Q26	Q27	Q28	Q29	Q30
2	3	2	3	4	3	4	2	4	1	4	2	2

- 31)a)Both have wings/eyes/heads/legs.  
b)The bird has a beak but the bee does not have a beak.  
The bird has 2 legs but the bee has 6 legs.  
The bird has a pair of wings but the bee has 2 pairs of wings.

- 32)a)Material E is transparent but Material F is not transparent.  
b)Both of them do not break when dropped.  
c)Material G does not break when dropped and it is flexible.

- 33)a)The small intestine.

b)

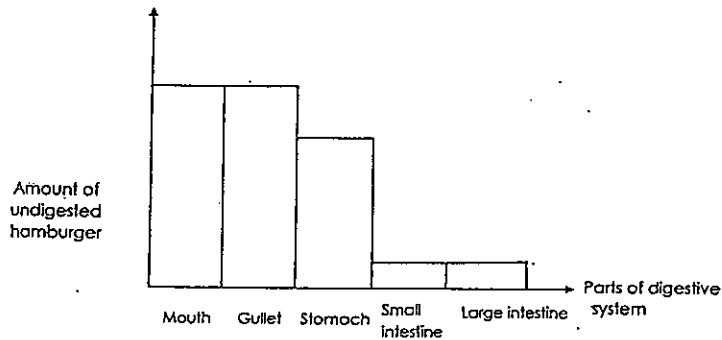

33)c)

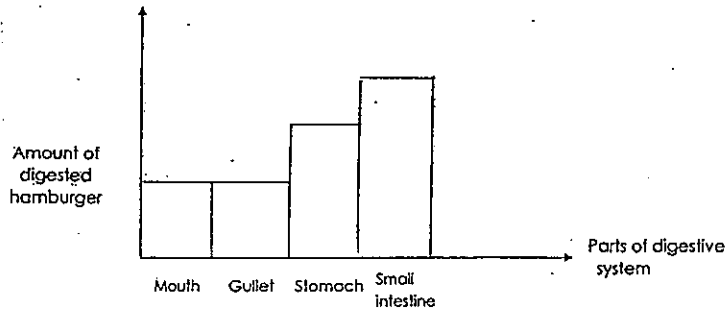

34)a) Changed

Kept the same

b) C. It is the best conductor of heat. Heat took the shortest time to travel through the rod to melt the ring of wax.

35)a) Heat flowed from the flame through the metal rods to the wax.

b) Metal rod A is a better conductor of heat than metal rod B, and heat travelled faster to melt the wax.

c) Move the flame towards thumbtack.

36)a) As the distance between the light source and material increases. The amount of light reflected decreases.

b) Material Q.

c) Material B can reflect light better. The safety vest for cyclist needs to reflect light well in order for drivers to see them.

37)a)

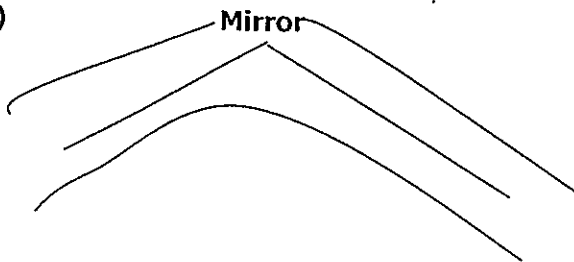

b) Light travels in a straight line and light can get reflected.

38)a) i)



ii)





- 39)a)Material C is most suitable.  
b)Material C is the poorest conductor of heat, so the least amount of ice has melted.
- 40)a)Ring Y is made of non-magnetic material.  
b)Y is non-magnetic and allows magnetism to pass through it so that X and Z were attracted to each other.  
c)Iron/steel/Nickel/cobalt
- 41)a)As the number of coils around the iron rod increases, the number of paper clips picked.  
b)Add more batteries.
- 42)a)i)South ii)North  
b)If Daryl's method is used, the steel bar will not have a distinct poles at ends X and Y.
- 43)a)i)F ii)T iii)F iv)F  
b)Bring one end of Magnet W to both ends of Metal X. If one end is attracted the other end repels the magnet, then Metal X is a magnet.
- 44)a)4  
b)A C D B  
c)The longer the pulling distance, the stronger the magnet is.

