

Name:	Class:	Class Register Number:
-------	--------	------------------------



中正中学

CHUNG CHENG HIGH SCHOOL (MAIN)

Chung Cheng High School Chung Cheng High School Chung Cheng High School Chung Cheng High School Chung Cheng High School
 Chung Cheng High School Chung Cheng High School Chung Cheng High School Chung Cheng High School Chung Cheng High School
 Chung Cheng High School Chung Cheng High School Chung Cheng High School Chung Cheng High School Chung Cheng High School
 Chung Cheng High School Chung Cheng High School Chung Cheng High School Chung Cheng High School Chung Cheng High School
 Chung Cheng High School Chung Cheng High School Chung Cheng High School Chung Cheng High School Chung Cheng High School

Parent's Signature

PRELIMINARY EXAMINATION 2018

SECONDARY 4

MATHEMATICS

4048/01

Paper 1

11 September 2018

2 hours

Candidates answer on the Question Paper.

READ THESE INSTRUCTIONS FIRST

Write your name, class and index number clearly on all the work you hand in.

Write in dark blue or black pen.

You may use an HB pencil for any diagrams or graphs.

Do not use staples, paper clips, glue or correction fluid.

Answer **all** questions.

If working is needed for any question it must be shown with the answer.

Omission of essential working will result in loss of marks.

The use of an approved scientific calculator is expected, where appropriate.

If degree of accuracy is not specified in the question, and if the answer is not exact, give the answer to three significant figures. Give answers in degrees to one decimal place.

For π , use either your calculator value or 3.142, unless the question requires the answer in terms of π .

At the end of the examination, fasten all your work securely together.

The number of marks is given in brackets [] at the end of each question or part question.

The total number of marks for this paper is 80.

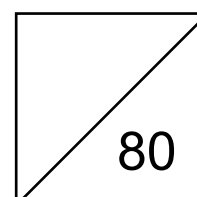

Mathematical Formulae*Compound interest*

$$\text{Total amount} = P \left(1 + \frac{r}{100} \right)^n$$

Mensuration

$$\text{Curved surface area of a cone} = \pi r l$$

$$\text{Surface area of a sphere} = 4 \pi r^2$$

$$\text{Volume of a cone} = \frac{1}{3} \pi r^2 h$$

$$\text{Volume of a sphere} = \frac{4}{3} \pi r^3$$

$$\text{Area of triangle } ABC = \frac{1}{2} a b \sin C$$

$$\text{Arc length} = r \theta, \text{ where } \theta \text{ is in radians}$$

$$\text{Sector area} = \frac{1}{2} r^2 \theta, \text{ where } \theta \text{ is in radians}$$

Trigonometry

$$\frac{a}{\sin A} = \frac{b}{\sin B} = \frac{c}{\sin C}$$

$$a^2 = b^2 + c^2 - 2 b c \cos A$$

Statistics

$$\text{Mean} = \frac{\sum f x}{\sum f}$$

$$\text{Standard deviation} = \sqrt{\frac{\sum f x^2}{\sum f} - \left(\frac{\sum f x}{\sum f} \right)^2}$$

Answer **all** the questions.

- 1 If $a = \frac{4}{3}b$ and $b = \frac{5}{6}c$, write down the ratio of $a : b : c$.

Answer [1]

- 2 If x and y are integer values, such that $-8 \leq x \leq 7$ and $-1 \leq y \leq 5$, find

(a) the smallest possible value of $2y - x^2$,

Answer [1]

(b) the largest possible value of $-(y^3x)$.

Answer [1]

3 Solve $\frac{2x-3}{2} - \frac{x+6}{6} = \frac{2}{9}$.

Answer $x = \dots\dots\dots$ [3]

4 (a) Simplify $7x - 4y - 4(x - 5y)$.

Answer $\dots\dots\dots$ [1]

(b) Express $\frac{2x}{x^2-1} + \frac{3}{1-x}$ as a single fraction.

Answer $\dots\dots\dots$ [3]

5 (a) Solve $49^{2x+1} \div \sqrt[3]{7} = \frac{1}{343}$.

Answer $x = \dots\dots\dots$ [3]

(b) Without using a calculator, show that $3^{1161} + 3^{1158}$ is exactly divisible by 7.

Answer

.....

.....

.....

.....

.....

.....

.....

.....

.....

.....

.....

[2]

6 The diagram shows the speed–time graph for a car’s journey.

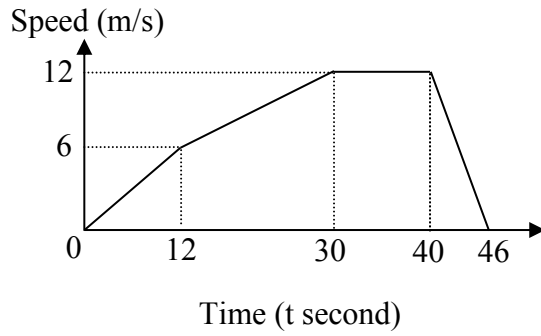

Calculate

(a) the acceleration of the car during the first 12 seconds,

Answer m/s² [1]

(b) the speed of the car when $t = 18$,

Answer m/s [2]

(c) the total distance travelled in the first 40 seconds.

Answer m [2]

$$7 \quad W = 6\sqrt{\frac{y^3 - x^2}{7}}$$

- (a) Calculate the value of W when $y = 5$ and $x = -4$. Write your answer correct to two decimal places.

Answer [1]

- (b) Rearrange the formula to make x the subject.

Answer [3]

- 8 A, B, C, D, \dots is part of a regular polygon. Given that reflex angle $ABC = 225^\circ$, how many sides does the polygon have?

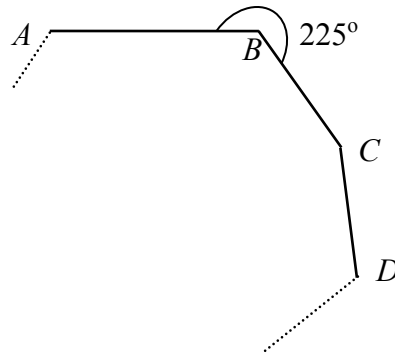

Answer [2]

- 9 In a particular school, the enrolment in 2016 is 900 students. In 2015, there were 20% more students than in 2016. There were 20% less students in 2016 as compared to 2017.

Calculate the enrolment in

- (a) 2015,

Answer [1]

- (b) 2017.

Answer [1]

- 10 A, B, C and D are four points on the circumference of a circle with centre O . ST is a tangent to the circle at B . It is given that angle $ADB = 50^\circ$ and angle $CBS = 42^\circ$. Calculate, showing your working clearly,

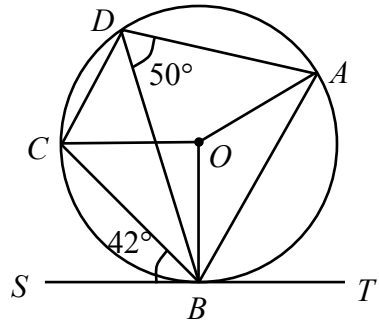

- (a) angle COB ,

Answer Angle $COB = \dots\dots\dots$ [2]

- (b) angle CDB ,

Answer Angle $CDB = \dots\dots\dots$ [1]

- (c) angle AOC .

Answer Angle $AOC = \dots\dots\dots$ [2]

11 (a) Given that $4x^2 - 12xy + 9y^2 = 0$, find the value of $\frac{4x}{15y}$.

Answer [3]

(b) Factorise $a^2 + 2ab + b^2 - 4b^2c^2$ completely.

Answer [2]

- 12 The diagram shows a circle $ABCD$. The diagonals AC and BD intersect at X . It is given that $BX = 2$ cm, $AB = 5$ cm and $DC = 9$ cm.

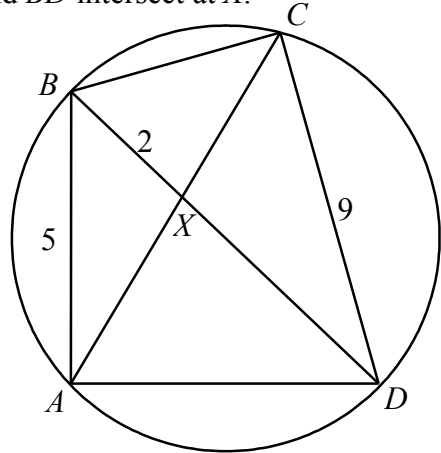

- (a) Prove, stating your reasons clearly, that triangle ABX is similar to triangle DCX .

Answer

.....

.....

.....

.....

..... [2]

- (b) Find the length of CX .

Answercm [1]

- (c) Find $\frac{\text{area of triangle } ABX}{\text{area of triangle } DCX}$.

Answer [1]

- 13 Twenty four boys took part in the high jump event in a school sports meet. Their records in centimetres are shown in the stem-and-leaf diagram.

Stem	Leaf
11	0 2
12	1 2 6
13	
14	2 3 3 4 4 5 5
15	6 6 7 7
16	0 0 1 1 5 5 5 6

Key : 11 | 0 represents 110 cm

- (a) Find the interquartile range.

Answercm [1]

- (b) Find

- (i) the modal distance,

Answercm [1]

- (ii) the median distance,

Answercm [1]

- (iii) the mean distance.

Answercm [1]

- (c) Would you use the mode or the median as the most appropriate measure of average in this case? Justify your answer.

Answer

.....

.....

..... [1]

- 14 (a) Construct the quadrilateral $ABCD$ such that angle $ABC = 70^\circ$, $BC = 11$ cm, $AD = 6$ cm and angle $BAD = 110^\circ$. Line AB has already been drawn. [2]

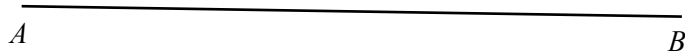

- (b) State the special name of this quadrilateral.

Answer [1]

- (c) Construct the perpendicular bisector of BC . [1]

- (d) Construct the angle bisector of $\angle BCD$. [1]

- (e) Label the intersection between the bisectors in (c) and (d) as Y . Name an isosceles triangle from the diagram.

Answer Triangle..... [1]

- 15 $\xi = \{\text{integers } x : 1 \leq x \leq 15\}$
 $A = \{\text{integers divisible by } 2\}$
 $B = \{\text{integers divisible by } 3\}$

(a) Draw a Venn Diagram to illustrate this information. [2]

(b) List the elements contained in the set $(A \cup B)'$.

Answer [1]

(c) Describe, as simply as possible, in words, the elements contained in the set $A \cap B$.

Answer [1]

16 It is given that y is inversely proportional to the cube of x . If x is doubled, find the percentage decrease in y .

Answer% [3]

17 Small squares are used to form a series of big squares as shown below.

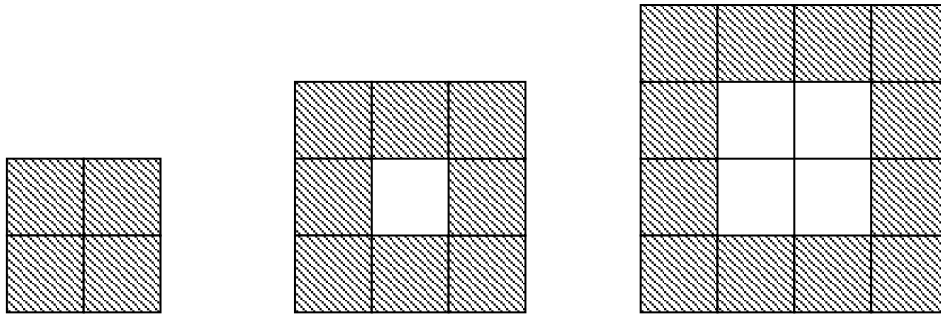

(a) Complete the following table: [2]

Length of side of big square (n)	Number of shaded small squares (S)	Number of unshaded small squares (U)
2	4	0
3	8	1
4	12	4
5	16	9
6		

(b) Find an equation connecting U , the number of unshaded small squares, and n , the length of side of big square.

Answer [1]

(c) How many unshaded small squares are there in a big square if the length of the big square is 13?

Answer [1]

(d) Explain why the number of unshaded small squares (U) cannot be 288.

Answer

.....

.....

.....

..... [1]

18 Ethan invested some money in a bank for 3 years. The rate of compound interest was fixed at 2% per annum. At the end of 3 years, Ethan has a total of \$3077.50 in his account. What was the amount of money that Ethan invested at the beginning?

Answer \$..... [3]

19 (a) Express $6x + x^2 + 15$ in the form of $a + (x + b)^2$.

Answer [2]

(b) Hence sketch the graph of $y = 6x + x^2 + 15$.

[2]

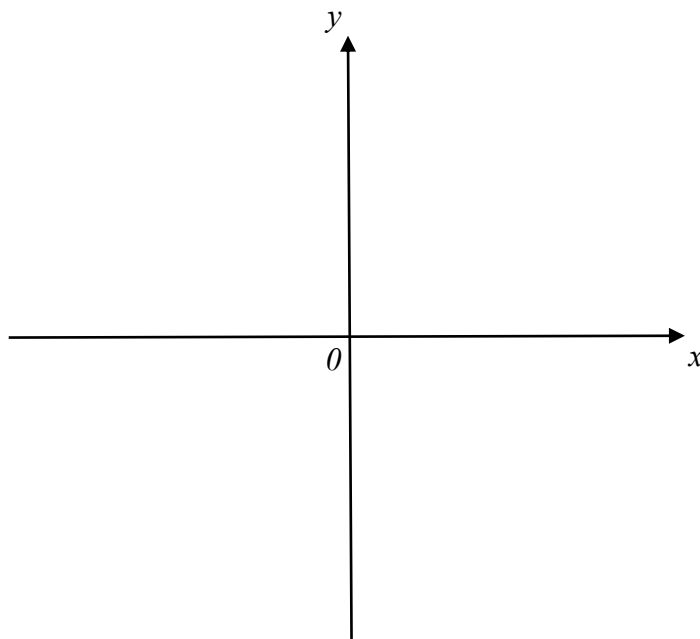

- 20 The daily expenses of 1040 students in School *X* are recorded. The cumulative frequency curve in **Diagram I** below shows the distribution of their expenses.

Cumulative frequency

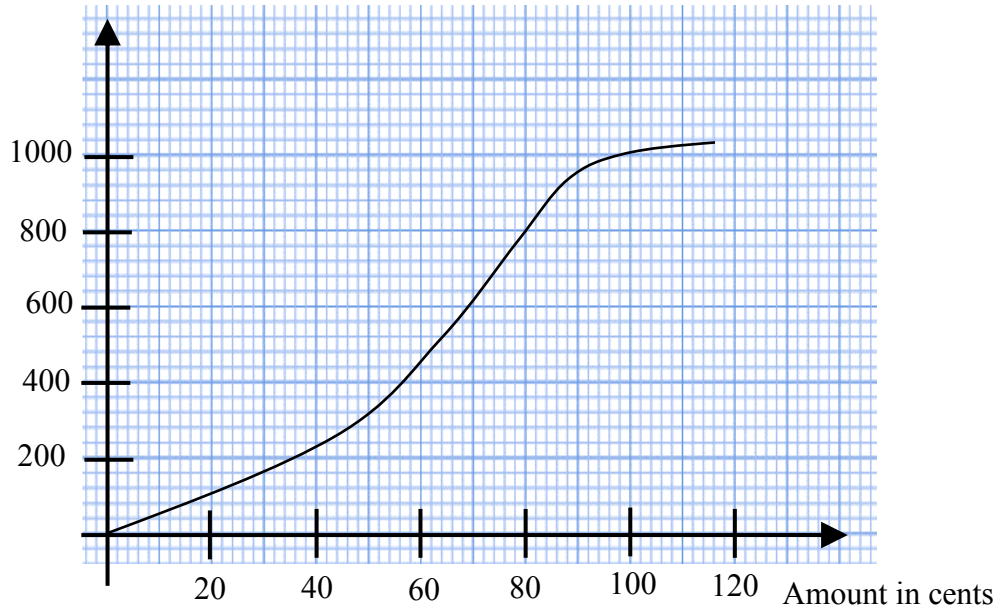

Diagram I

- (a) Use the curve to estimate

(i) the median,

Answercents [1]

(ii) the interquartile range.

Answercents [1]

- (b) The expenses of 1040 students in another School *Y* had the same median but a smaller interquartile range. Draw a possible cumulative curve to show the distribution of the students' expenses for School *Y* on **Diagram I**.

[1]

21 The table below shows the number of cups of four types of flavoured tea sold by a café on Monday, Tuesday and Wednesday, and the respective selling price and cost price of each type of flavoured tea.

	Green	Plum	Lemon	Assam
Monday	33	47	34	18
Tuesday	40	25	56	34
Wednesday	56	73	21	51
Selling price per cup	\$3.20	\$3.80	\$3.00	\$3.50
Cost price per cup	\$1.60	\$2.00	\$1.70	\$1.80

(a) Express the profit made per cup for each type of flavoured tea as a single row matrix **P**.

Answer **P** = [1]

(b) Find using matrix multiplication, a 1×3 matrix **R** which represents the profit made from selling the flavoured tea on Monday, Tuesday and Wednesday respectively.

Answer **R** = [2]

(c) Evaluate the matrix $\mathbf{Q} = \mathbf{R} \begin{pmatrix} 1 \\ 1 \\ 1 \end{pmatrix}$ and explain what the element in **Q** represents.

Answer **Q** = [1]

Answer The element in **Q** represents

.....

..... [1]

Answers

1 20 : 15 : 18

2 (a) -66 (b) 1000

3 $x = 3\frac{4}{15}$

4 (a) $3x + 16y$ (b) $\frac{-x-3}{(x+1)(x-1)}$ OR $\frac{x+3}{(x+1)(1-x)}$ OR $-\frac{x+3}{(x+1)(x-1)}$

5 (a) $x = -1\frac{1}{6}$

(b) $3^{1161} + 3^{1158} = 2^2 \times 7 \times 3^{1158}$

Since $3^{1161} + 3^{1158}$ has a factor 7, therefore it is divisible by 7.

OR Since $3^{1161} + 3^{1158}$ has a factor 28, and 28 is divisible by 7 therefore it is divisible by 7.

OR 28 is a multiple of 7 therefore $3^{1161} + 3^{1158}$ is divisible by 7.

OR 7 is a factor of 28 therefore $3^{1161} + 3^{1158}$ is divisible by 7.

Without using a calculator, show that is exactly divisible by 7.

6 (a) $\frac{1}{2}$ m/s² (b) 8 m/s (c) 318 m

7 (a) 23.68 (b) $x = \pm \sqrt{\frac{36y^3 - 7W^2}{36}}$

8 8

9 (a) 1080 (b) 1125

10 (a) 84° (b) 42° (c) 176°

11 (a) $\frac{2}{5}$ (b) $(a+b+2bc)(a+b-2bc)$

12 (a) triangle *ABX* is similar to triangle *DCX* (AA similarity)

(b) $3\frac{3}{5}$ cm (c) $\frac{25}{81}$

- 13 (a) 18 cm (b)(i) 165 cm (b)(ii) 150.5 cm (b)(iii) 147 or $146\frac{11}{12}$ cm

(c) The modal distance is not suitable as it is far away from the rest of the data.

Since the above distribution is skewed (not normal), thus I would use the median.

(Any reasonable answer)

- 14 (a)

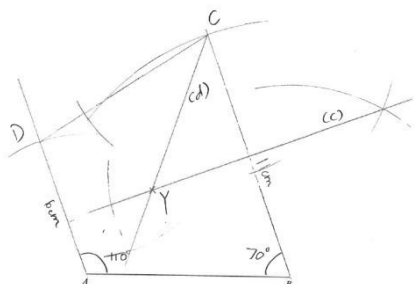

- 14 (b) Trapezium (d) Triangle CYB

- 15 (a) ξ

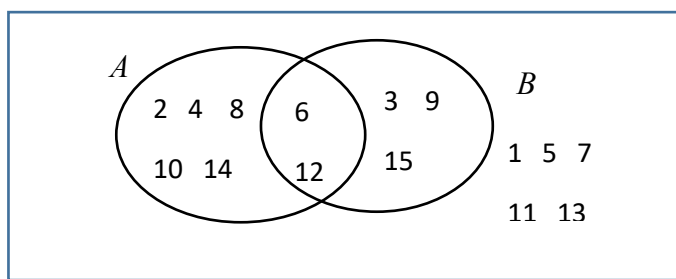

(b) $\{1, 5, 7, 11, 13\}$

(c) Elements in set $A \cap B$ are positive integers that are less than or equal to 15 and is divisible by 6.

- 16 87.5 %

- 17 (a) 20, 16 (b) $U = (n-2)^2$ or $U = n^2 - 4n + 4$ (c) 121

(d) The number of unshaded squares (U) cannot be 288 as 288 is not a perfect square.

- 18 \$2900.00

- 19 (a) $6 + (x+3)^2$

(b)

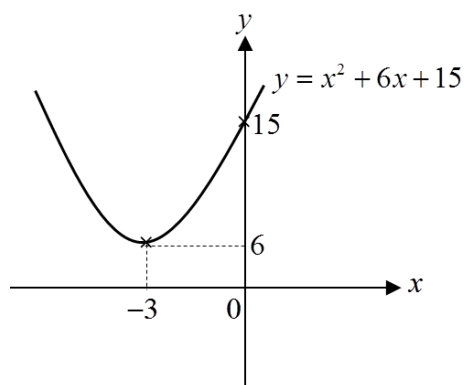

- 20 (a)(i) 64 cents (a)(ii) 35 cents. (b) The interquartile range must be smaller with the same median.

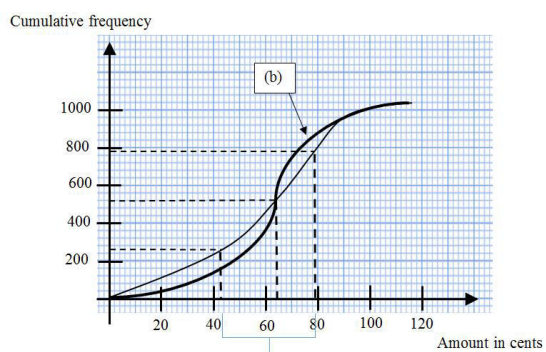

Diagram I

- 21 (a) $P = (1.6 \ 1.8 \ 1.3 \ 1.7)$ (b) $R = (212.2 \ 239.6 \ 335)$
 (c) $Q = (786.8)$.

The element in Q represents the total profit made by this café from the sale of flavoured tea from these 3 days.

Name:	Class:	Class Register Number:
-------	--------	------------------------



中正中学

CHUNG CHENG HIGH SCHOOL (MAIN)

Chung Cheng High School Chung Cheng High School Chung Cheng High School Chung Cheng High School Chung Cheng High School
 Chung Cheng High School Chung Cheng High School Chung Cheng High School Chung Cheng High School Chung Cheng High School
 Chung Cheng High School Chung Cheng High School Chung Cheng High School Chung Cheng High School Chung Cheng High School
 Chung Cheng High School Chung Cheng High School Chung Cheng High School Chung Cheng High School Chung Cheng High School
 Chung Cheng High School Chung Cheng High School Chung Cheng High School Chung Cheng High School Chung Cheng High School

PRELIMINARY EXAMINATION 2018	
SECONDARY 4	
MATHEMATICS	4048/01
Paper 1	11 September 2018
	2 hours
Answer Scheme	

This document consists of **19** printed pages and **1** blank page.

Mathematical Formulae

Compound interest

$$\text{Total amount} = P \left(1 + \frac{r}{100} \right)^n$$

Mensuration

$$\text{Curved surface area of a cone} = \pi r l$$

$$\text{Surface area of a sphere} = 4 \pi r^2$$

$$\text{Volume of a cone} = \frac{1}{3} \pi r^2 h$$

$$\text{Volume of a sphere} = \frac{4}{3} \pi r^3$$

$$\text{Area of triangle } ABC = \frac{1}{2} a b \sin C$$

$$\text{Arc length} = r \theta, \text{ where } \theta \text{ is in radians}$$

$$\text{Sector area} = \frac{1}{2} r^2 \theta, \text{ where } \theta \text{ is in radians}$$

Trigonometry

$$\frac{a}{\sin A} = \frac{b}{\sin B} = \frac{c}{\sin C}$$

$$a^2 = b^2 + c^2 - 2 b c \cos A$$

Statistics

$$\text{Mean} = \frac{\sum f x}{\sum f}$$

$$\text{Standard deviation} = \sqrt{\frac{\sum f x^2}{\sum f} - \left(\frac{\sum f x}{\sum f} \right)^2}$$

Answer **all** the questions.

- 1 If $a = \frac{4}{3}b$ and $b = \frac{5}{6}c$, write down the ratio of $a : b : c$.

$$\frac{a}{b} = \frac{4}{3}$$

$$= \frac{20}{15}$$

$$\frac{b}{c} = \frac{5}{6}$$

$$= \frac{15}{18}$$

$$\therefore a : b : c = 20 : 15 : 18$$

Answer 20 : 15 : 18 [1]

- 2 If x and y are integer values, such that $-8 \leq x \leq 7$ and $-1 \leq y \leq 5$, find

- (a) the smallest possible value of $2y - x^2$,

smallest possible value of

$$2y - x^2 = 2(-1) - (-8)^2$$

$$= -66$$

Answer -66 [1]

- (b) the largest possible value of $-(y^3x)$.

largest possible value of

$$-(y^3x) = -[(5)^3(-8)]$$

$$= 1000$$

Answer 1000 [1]

3 Solve $\frac{2x-3}{2} - \frac{x+6}{6} = \frac{2}{9}$.

$$\begin{aligned} \frac{2x-3}{2} - \frac{x+6}{6} &= \frac{2}{9} \\ \frac{9(2x-3) - 3(x+6)}{18} &= \frac{4}{18} && \text{OR} && 9(2x-3) - 3(x+6) = 4 \\ 18x - 27 - 3x - 18 &= 4 \\ 15x &= 49 \\ x &= \frac{49}{15} \\ &= 3\frac{4}{15} \end{aligned}$$

Answer $x = 3\frac{4}{15}$ [3]

4 (a) Simplify $7x - 4y - 4(x - 5y)$.

$$\begin{aligned} 7x - 4y - 4(x - 5y) &= 7x - 4y - 4x + 20y \\ &= 3x + 16y \end{aligned}$$

Answer $3x + 16y$ [1]

(b) Express $\frac{2x}{x^2-1} + \frac{3}{1-x}$ as a single fraction.

$$\begin{aligned} \frac{2x}{x^2-1} + \frac{3}{1-x} &= \frac{2x}{(x+1)(x-1)} - \frac{3}{x-1} \\ &= \frac{2x - 3(x+1)}{(x+1)(x-1)} \\ &= \frac{-x-3}{(x+1)(x-1)} \end{aligned} \quad \begin{aligned} x^2 - 1 &= (x+1)(x-1) \\ -\frac{3}{x-1} & \end{aligned}$$

OR $\frac{x+3}{(x+1)(1-x)}$ OR $-\frac{x+3}{(x+1)(x-1)}$

OR $\frac{2x}{x^2-1} + \frac{3}{1-x} = \frac{2x(1-x) + 3(x^2-1)}{(x^2-1)(1-x)}$

$$\begin{aligned} &= \frac{2x - 2x^2 + 3x^2 - 3}{(x^2-1)(1-x)} \\ &= \frac{x^2 + 2x - 3}{(x^2-1)(1-x)} \\ &= \frac{(x+3)(x-1)}{(x^2-1)(1-x)} \\ &= \frac{(x+3)(x-1)}{(x+1)(x-1)(1-x)} \\ &= \frac{x+3}{(x+1)(1-x)} \end{aligned}$$

Answer $\frac{-x-3}{(x+1)(x-1)}$ [3]

5 (a) Solve $49^{2x+1} \div \sqrt[3]{7} = \frac{1}{343}$.

$$49^{2x+1} \div \sqrt[3]{7} = \frac{1}{343}$$

$$7^{2(2x+1)} \div 7^{\frac{1}{3}} = \frac{1}{7^3}$$

$$7^{4x+2-\frac{1}{3}} = 7^{-3}$$

By comparing,

$$4x + 2 - \frac{1}{3} = -3$$

$$x = (-3 - 2 + \frac{1}{3}) \div 4$$

$$= -1\frac{1}{6}$$

Answer $x = -1\frac{1}{6}$ [3]

(b) Without using a calculator, show that $3^{1161} + 3^{1158}$ is exactly divisible by 7.

Answer

$$\begin{aligned} 3^{1161} + 3^{1158} &= 3^{1158}(1 + 3^3) \\ &= 3^{1158}(28) \\ &= 2^2 \times 7 \times 3^{1158} \end{aligned}$$

Since $3^{1161} + 3^{1158}$ has a factor 7, therefore it is divisible by 7.

OR Since $3^{1161} + 3^{1158}$ has a factor 28, and 28 is divisible by 7 therefore it is divisible by 7.

OR 28 is a multiple of 7 therefore $3^{1161} + 3^{1158}$ is divisible by 7.

OR 7 is a factor of 28 therefore $3^{1161} + 3^{1158}$ is divisible by 7.

[2]

- 6 The diagram shows the speed–time graph for a car’s journey.

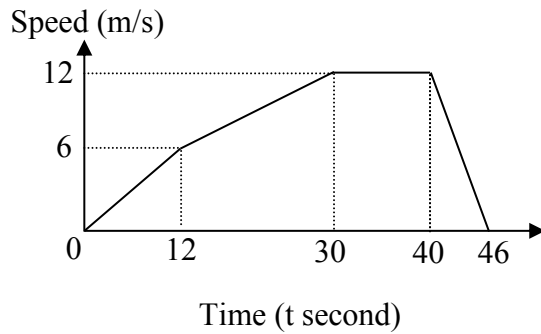

Calculate

- (a) the acceleration of the car during the first 12 seconds,

$$\begin{aligned} \text{Acceleration} &= \frac{6-0}{12-0} \\ &= \frac{1}{2} \text{ m/s}^2 \end{aligned}$$

Answer $\frac{1}{2} \text{ m/s}^2$ [1]

- (b) the speed of the car when $t = 18$,

Let the speed of the car be v at $t = 18$

$$\begin{aligned} \frac{v-6}{18-12} &= \frac{12-6}{30-12} \\ v &= \frac{6}{18} \times 6 + 6 \\ &= 8 \text{ m/s} \end{aligned}$$

Answer 8 m/s [2]

- (c) the total distance travelled in the first 40 seconds.

$$\begin{aligned} &\text{Total distance travelled in first 40 seconds} \\ &= \frac{1}{2} \times 6 \times 12 + \frac{1}{2} (6+12) \times 18 + 12 \times 10 \\ &= 318 \text{ m} \end{aligned}$$

Answer 318 m [2]

$$7 \quad W = 6\sqrt{\frac{y^3 - x^2}{7}}$$

- (a) Calculate the value of W when $y = 5$ and $x = -4$. Write your answer correct to two decimal places.

$$W = 6\sqrt{\frac{y^3 - x^2}{7}}$$

$$W = 6\sqrt{\frac{5^3 - (-4)^2}{7}}$$

$$= 23.6763\dots$$

$$= 23.68 \text{ (correct to 2 dp.)}$$

Answer 23.68 [1]

- (b) Rearrange the formula to make x the subject.

$$W = 6\sqrt{\frac{y^3 - x^2}{7}}$$

$$\frac{W}{6} = \sqrt{\frac{y^3 - x^2}{7}}$$

$$\left(\frac{W}{6}\right)^2 = \frac{y^3 - x^2}{7}$$

$$7\left(\frac{W}{6}\right)^2 = y^3 - x^2$$

$$x^2 = y^3 - \frac{7W^2}{36}$$

$$= \frac{36y^3 - 7W^2}{36}$$

$$x = \pm\sqrt{\frac{36y^3 - 7W^2}{36}}$$

Answer $x = \pm\sqrt{\frac{36y^3 - 7W^2}{36}}$ [3]

- 8 A, B, C, D, \dots is part of a regular polygon. Given that reflex angle $ABC = 225^\circ$, how many sides does the polygon have?

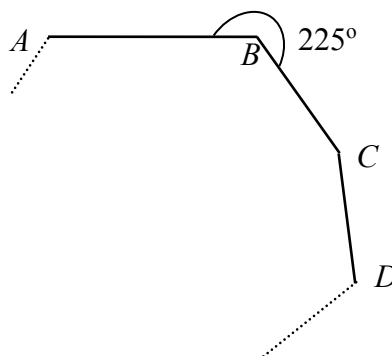

Interior angle = $360^\circ - 225^\circ$ (angles at a point)

$$= 135^\circ$$

$$(n - 2)180 = 135n$$

$$180n - 135n = 360$$

$$n = \frac{360}{45}$$

$$= 8$$

OR

Exterior angle = $180^\circ - 135^\circ$

$$= 45^\circ$$

$$n = \frac{360}{45}$$

$$= 8$$

Number of sides = 8

Answer 8

[2]

- 9 In a particular school, the enrolment in 2016 is 900 students. In 2015, there were 20% more students than in 2016. There were 20% less students in 2016 as compared to 2017.

Calculate the enrolment in

- (a) 2015,

Number of students in 2015

$$= \frac{120}{100} \times 900$$

$$= 1080$$

Answer

1080

[1]

- (b) 2017.

Number of students in 2017

$$= \frac{100}{80} \times 900$$

$$= 1125$$

Answer

1125

[1]

- 10 A, B, C and D are four points on the circumference of a circle with centre O . ST is a tangent to the circle at B . It is given that angle $ADB = 50^\circ$ and angle $CBS = 42^\circ$. Calculate, showing your working clearly,

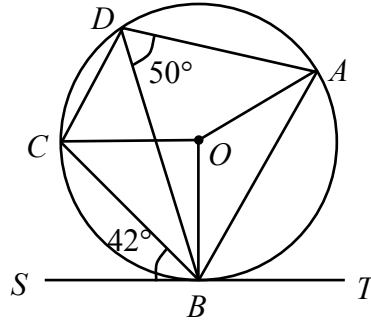

- (a) angle COB ,

$$\text{angle } SBO = 90^\circ \text{ (tangent } \perp \text{ radius)}$$

$$\text{angle } CBO = 90^\circ - 42^\circ$$

$$= 48^\circ$$

$$\text{angle } BCO = 48^\circ \text{ (base angles of isosceles triangle)}$$

$$\text{angle } COB = 180^\circ - 48^\circ \times 2 \text{ (angles sum of triangle)}$$

$$= 84^\circ$$

$$\text{Answer Angle } COB = 84^\circ \quad [2]$$

- (b) angle CDB ,

$$\text{angle } CDB = \frac{1}{2} \times 84^\circ \text{ (angle at centre is twice angle at circumference)}$$

$$= 42^\circ$$

$$\text{Answer Angle } CDB = 42^\circ \quad [1]$$

- (c) angle AOC .

$$\text{angle } ABC = 180^\circ - (50^\circ + 42^\circ) \text{ (angles in opposite segment)}$$

$$= 88^\circ$$

$$\text{angle } AOC = 2 \times 88^\circ \text{ (angle at centre is twice angle at the circumference)}$$

$$= 176^\circ$$

OR

$$\text{angle } BOA = 2 \times 50^\circ \text{ (angle at centre is twice angle at the circumference)}$$

$$= 100^\circ$$

$$\text{angle } AOC = 360^\circ - 84^\circ - 100^\circ \text{ (angles at a point)}$$

$$= 176^\circ$$

$$\text{Answer Angle } AOC = 176^\circ \quad [2]$$

- 11 (a) Given that $4x^2 - 12xy + 9y^2 = 0$, find the value of $\frac{4x}{15y}$.

$$4x^2 - 12xy + 9y^2 = 0$$

$$(2x - 3y)^2 = 0$$

$$2x - 3y = 0$$

$$2x = 3y$$

$$\frac{x}{y} = \frac{3}{2}$$

$$\frac{4x}{15y} = \left(\frac{3}{2}\right)\left(\frac{4}{15}\right)$$

$$= \frac{2}{5}$$

Answer $\frac{2}{5}$ [3]

- (b) Factorise $a^2 + 2ab + b^2 - 4b^2c^2$ completely.

$$\begin{aligned} a^2 + 2ab + b^2 - 4b^2c^2 &= (a + b)^2 - (2bc)^2 \\ &= (a + b + 2bc)(a + b - 2bc) \end{aligned}$$

Answer $(a + b + 2bc)(a + b - 2bc)$ [2]

- 12 The diagram shows a circle $ABCD$. The diagonals AC and BD intersect at X . It is given that $BX = 2$ cm, $AB = 5$ cm and $DC = 9$ cm.

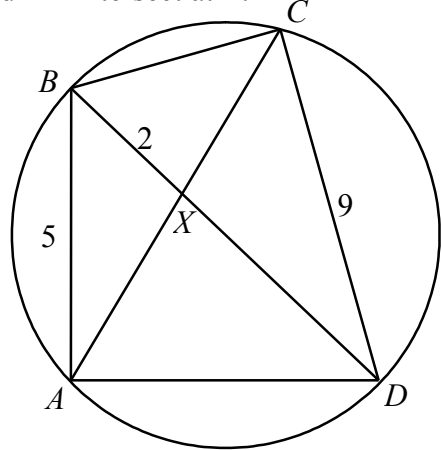

- (a) Prove, stating your reasons clearly, that triangle ABX is similar to triangle DCX .

Answer

angle $BXA =$ angle CXD (vertically opposite angles) }
 angle $ABX =$ angle DCX (angle in the same segment) }

Therefore triangle ABX is similar to triangle DCX (AA similarity)

[2]

- (b) Find the length of CX .

$$\frac{CX}{BX} = \frac{CD}{BA} \text{ (ratios of corresponding side are equal)}$$

$$\frac{CX}{2} = \frac{9}{5}$$

$$CX = \frac{9}{5} \times 2$$

$$= 3\frac{3}{5}$$

Answer $3\frac{3}{5}$ cm [1]

- (c) Find $\frac{\text{area of triangle } ABX}{\text{area of triangle } DCX}$.

$$\frac{\text{area of triangle } ABX}{\text{area of triangle } DCX} = \left(\frac{5}{9}\right)^2$$

$$= \frac{25}{81}$$

Answer $\frac{25}{81}$ [1]

- 13 Twenty four boys took part in the high jump event in a school sports meet. Their records in centimetres are shown in the stem-and-leaf diagram.

Stem	Leaf
11	0 2
12	1 2 6
13	
14	2 3 3 4 4 5 5
15	6 6 7 7
16	0 0 1 1 5 5 5 6

Key : 11 | 0 represents 110 cm

- (a) Find the interquartile range.

$$\begin{aligned} \text{Lower quartile} &= \frac{142+143}{2} \\ &= 142.5 \text{ cm} \end{aligned}$$

$$\begin{aligned} \text{Upper quartile} &= \frac{160+161}{2} \\ &= 160.5 \text{ cm} \end{aligned}$$

$$\begin{aligned} \text{Interquartile range} &= 160.5 - 142.5 \\ &= 18 \text{ cm} \end{aligned}$$

Answer 18 cm [1]

- (b) Find

- (i) the modal distance,
modal distance = 165 cm

Answer 165 cm [1]

- (ii) the median distance,

$$\begin{aligned} \text{median distance} &= \frac{145+156}{2} \\ &= 150.5 \text{ cm} \end{aligned}$$

Answer 150.5 cm [1]

- (iii) the mean distance.

$$\begin{aligned} \text{mean distance} &= \frac{3526}{24} \\ &= 147 \text{ cm (3sf)} \end{aligned}$$

Answer 147 or $146\frac{11}{12}$ cm [1]

- (c) Would you use the mode or the median as the most appropriate measure of average in this case? Justify your answer.

Answer

The modal distance is not suitable as it is far away from the rest of the data. Since the above distribution is skewed (not normal), thus I would use the median. (Any reasonable answer)

[1]

- 14 (a) Construct the quadrilateral $ABCD$ such that angle $ABC = 70^\circ$, $BC = 11$ cm, $AD = 6$ cm and angle $BAD = 110^\circ$. Line AB has already been drawn. [2]

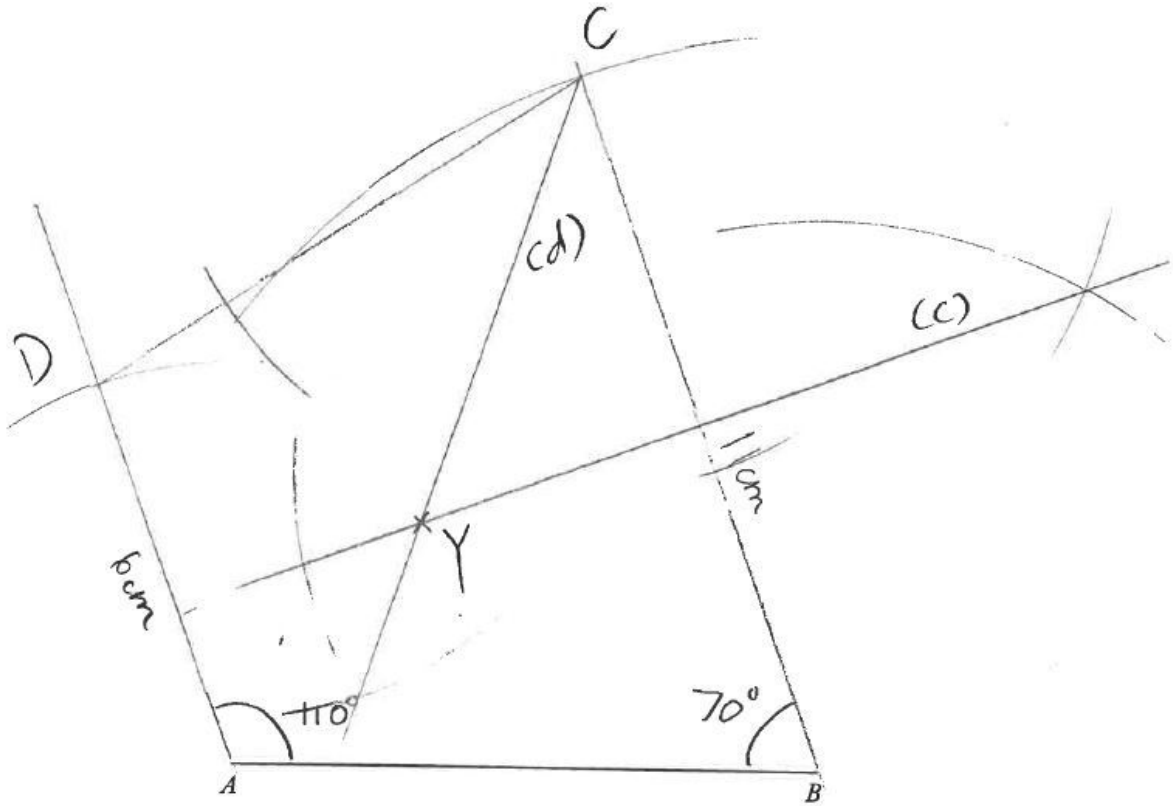

- (b) State the special name of this quadrilateral. Answer Trapezium [1]
- (c) Construct the perpendicular bisector of BC . [1]
- (d) Construct the angle bisector of $\angle BCD$. [1]
- (e) Label the intersection between the bisectors in (c) and (d) as Y . Name an isosceles triangle from the diagram.

Answer Triangle CYB [1]

- 15 $\xi = \{\text{integers } x : 1 \leq x \leq 15\}$
 $A = \{\text{integers divisible by } 2\}$
 $B = \{\text{integers divisible by } 3\}$

(a) Draw a Venn Diagram to illustrate this information.

[2]

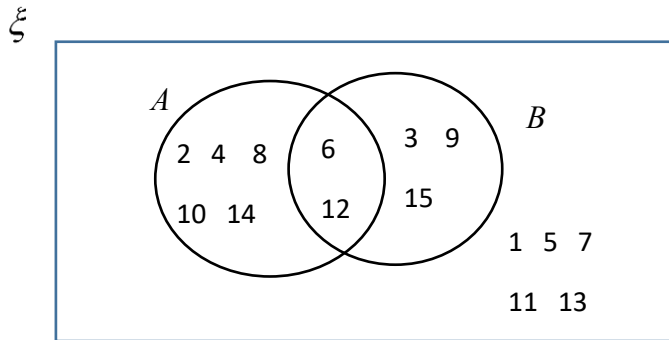

(b) List the elements contained in the set $(A \cup B)'$.

$$(A \cup B)' = \{1, 5, 7, 11, 13\}$$

Answer $\{1, 5, 7, 11, 13\}$ [1]

(c) Describe, as simply as possible, in words, the elements contained in the set $A \cap B$.

Answer

Elements in set $A \cap B$ are positive integers that are less than or equal to 15 and is divisible by 6. [1]

- 16 It is given that y is inversely proportional to the cube of x . If x is doubled, find the percentage decrease in y .

$$\text{Let } y_1 = \frac{k}{x^3} \quad \text{-----(1)}$$

$$y_2 = \frac{k}{(2x)^3} \quad \text{-----(1)}$$

$$\text{Percentage decrease in } y = \frac{\frac{k}{x^3} - \frac{k}{(2x)^3}}{\frac{k}{x^3}} \times 100\%$$

$$= \frac{\frac{k}{x^3} \left(1 - \frac{1}{8}\right)}{\frac{k}{x^3}} \times 100\%$$

$$= 87.5\%$$

Answer 87.5% [3]

17 Small squares are used to form a series of big squares as shown below.

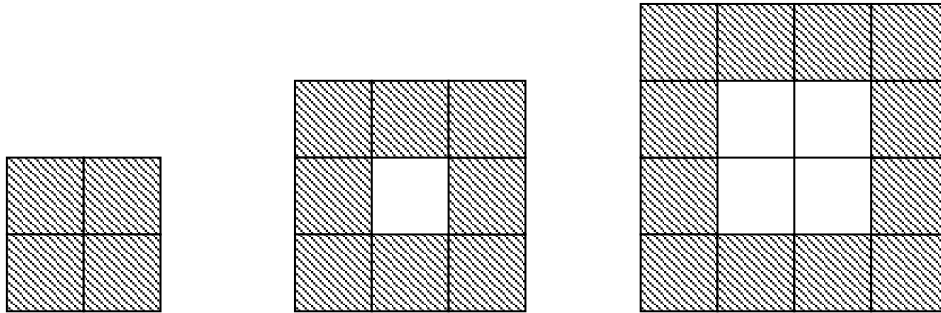

(a) Complete the following table: [2]

Length of side of big square (n)	Number of shaded small squares (S)	Number of unshaded small squares (U)
2	4	0
3	8	1
4	12	4
5	16	9
6	20	16

(b) Find an equation connecting U , the number of unshaded small squares, and n , the length of side of big square.

Answer $U = (n - 2)^2$ or
 $U = n^2 - 4n + 4$ [1]

(c) How many unshaded squares are there in a big square if the length of the big square is 13?

$$(13-2)^2 = 11^2$$

$$= 121$$

Answer 121 [1]

(d) Explain why the number of unshaded squares (U) cannot be 288.

Answer The number of unshaded squares (U) cannot be 288 as 288 is not a perfect square.

[1]

- 18** Ethan invested some money in a bank for 3 years. The rate of compound interest was fixed at 2% per annum. At the end of 3 years, Ethan has a total of \$3077.50 in his account. What was the amount of money that Ethan invested at the beginning?

$$P\left(1 + \frac{2}{100}\right)^3 = 3077.50$$

$$P = 3077.50 \div (1.02)^3$$

$$= 2899.996\dots$$

$$= 2900.00(\text{nearest cent})$$

The amount of money that Ethan invested at the beginning = \$2900.00

Answer \$2900.00 [3]

- 19 (a)** Express $6x + x^2 + 15$ in the form of $a + (x + b)^2$.

$$6x + x^2 + 15 = x^2 + 6x + 3^2 - 3^2 + 15$$

$$= 6 + (x + 3)^2$$

Answer $6 + (x + 3)^2$ [2]

- (b)** Hence sketch the graph of $y = 6x + x^2 + 15$. [2]

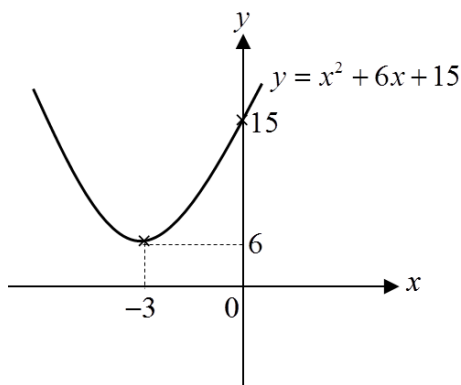

- 20 The daily expenses of 1040 students in School X are recorded. The cumulative frequency curve in **Diagram I** below shows the distribution of their expense.

Cumulative frequency

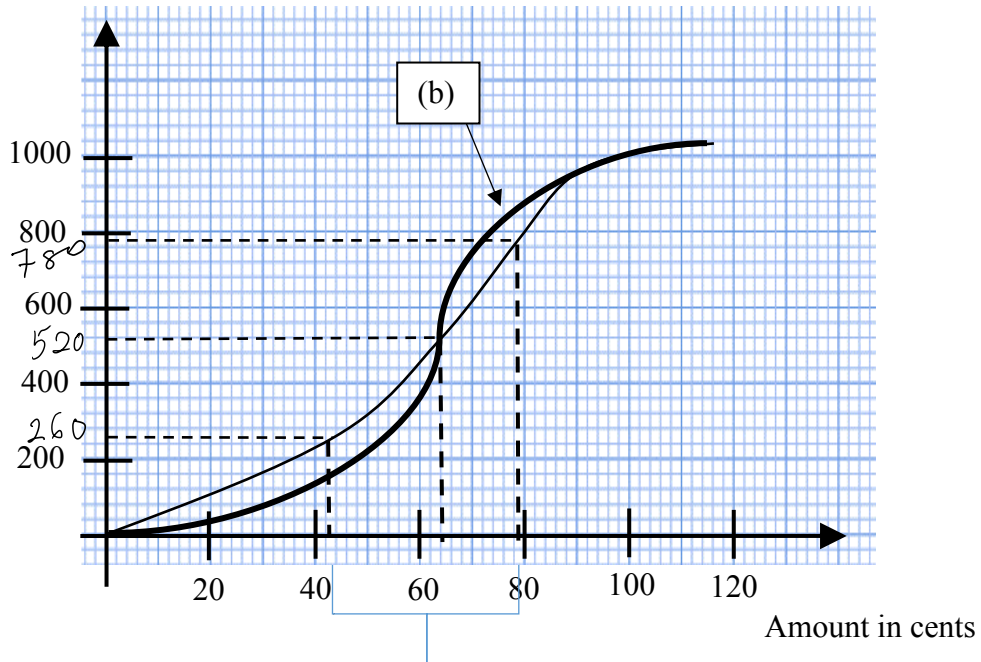

Diagram I

- (a) Use the curve to estimate

- (i) the median,

Median = 64 cents

Answer 64 cents [1]

- (ii) the interquartile range.

$$\begin{aligned} \text{Interquartile range} &= 79 - 44 \\ &= 35 \text{ cents} \end{aligned}$$

$$\begin{aligned} \text{OR Interquartile range} &= 78 - 44 \\ &= 34 \text{ cents} \end{aligned}$$

Answer 35 cents [1]
(can accept 34, 36)

- (b) The expenses of 1040 students in another School Y had the same median but a smaller interquartile range. Draw a possible cumulative curve to show the distribution of the students' expenses for School Y on **Diagram I**.
(The interquartile range must be smaller with the same median)

[1]

- 21 The table below shows the number of cups of different flavoured tea by a café on Monday, Tuesday and Wednesday, and the respective selling price and cost price of each kind of flavoured tea.

	Green	Plum	Lemon	Assam
Monday	33	47	34	18
Tuesday	40	25	56	34
Wednesday	56	73	21	51
Selling price per cup	\$3.20	\$3.80	\$3.00	\$3.50
Cost price per cup	\$1.60	\$2.00	\$1.70	\$1.80

- (a) Express the profit made per cup for each type of flavoured tea as a single row matrix **P**.
(1.6 1.8 1.3 1.7)

$$\text{Answer } \mathbf{P} = (1.6 \ 1.8 \ 1.3 \ 1.7) \quad [1]$$

- (b) Find using matrix multiplication, a 1×3 matrix **R** which represents the profit made from selling the flavoured tea on Monday, Tuesday and Wednesday respectively.

$$\mathbf{R} = (1.6 \ 1.8 \ 1.3 \ 1.7) \begin{pmatrix} 33 & 40 & 56 \\ 47 & 25 & 73 \\ 34 & 56 & 21 \\ 18 & 34 & 51 \end{pmatrix}$$

$$= (212.2 \ 239.6 \ 335)$$

$$\text{Answer } \mathbf{R} = (212.2 \ 239.6 \ 335) \quad [2]$$

- (c) Evaluate the matrix $\mathbf{Q} = \mathbf{R} \begin{pmatrix} 1 \\ 1 \\ 1 \end{pmatrix}$ and explain what the element in **Q** represents.

$$(212.2 \ 239.6 \ 335) \begin{pmatrix} 1 \\ 1 \\ 1 \end{pmatrix} = (212.2 + 239.6 + 335)$$

$$= (786.8)$$

$$\text{Answer } \mathbf{Q} = (786.8) \quad [1]$$

Answer The element in **Q** represents the total profit made by this café from the sale of flavoured tea from these 3 days. [1]

End of Paper

Name:	Class:	Class Register Number:
-------	--------	------------------------



中正中学

CHUNG CHENG HIGH SCHOOL (MAIN)

Chung Cheng High School Chung Cheng High School Chung Cheng High School Chung Cheng High School Chung Cheng High School
 Chung Cheng High School Chung Cheng High School Chung Cheng High School Chung Cheng High School Chung Cheng High School
 Chung Cheng High School Chung Cheng High School Chung Cheng High School Chung Cheng High School Chung Cheng High School
 Chung Cheng High School Chung Cheng High School Chung Cheng High School Chung Cheng High School Chung Cheng High School
 Chung Cheng High School Chung Cheng High School Chung Cheng High School Chung Cheng High School Chung Cheng High School

Parent's Signature

**PRELIMINARY EXAMINATION 2018
 SECONDARY 4**

MATHEMATICS

4048/02

Paper 2

13 September 2018

2 hours 30 minutes

Additional Materials : Answer Paper
 Graph paper (1 sheet)

READ THESE INSTRUCTIONS FIRST

Write your name, class and index number clearly on all the work you hand in.
 Write in dark blue or black pen.
 You may use an HB pencil for any diagrams or graphs.
 Do not use staples, paper clips, glue or correction fluid.

Answer **all** questions.
 If working is needed for any question it must be shown with the answer.
 Omission of essential working will result in loss of marks.
 The use of an approved scientific calculator is expected, where appropriate.
 If the degree of accuracy is not specified in the question, and if the answer is not exact, give the answer to three significant figures. Give answers in degrees to one decimal place.
 For π , use either your calculator value or 3.142, unless the question requires the answer in terms of π .

At the end of the examination, fasten all your work securely together.
 The number of marks is given in brackets [] at the end of each question or part question.
 The total of the marks for this paper is 100.

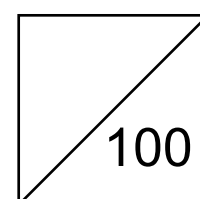

This document consists of **11** printed pages and **1** blank page.

Mathematical Formulae*Compound interest*

$$\text{Total amount} = P \left(1 + \frac{r}{100} \right)^n$$

Mensuration

$$\text{Curved surface area of a cone} = \pi r l$$

$$\text{Surface area of a sphere} = 4 \pi r^2$$

$$\text{Volume of a cone} = \frac{1}{3} \pi r^2 h$$

$$\text{Volume of a sphere} = \frac{4}{3} \pi r^3$$

$$\text{Area of triangle } ABC = \frac{1}{2} a b \sin C$$

$$\text{Arc length} = r \theta, \text{ where } \theta \text{ is in radians}$$

$$\text{Sector area} = \frac{1}{2} r^2 \theta, \text{ where } \theta \text{ is in radians}$$

Trigonometry

$$\frac{a}{\sin A} = \frac{b}{\sin B} = \frac{c}{\sin C}$$

$$a^2 = b^2 + c^2 - 2bc \cos A$$

Statistics

$$\text{Mean} = \frac{\Sigma fx}{\Sigma f}$$

$$\text{Standard deviation} = \sqrt{\frac{\Sigma fx^2}{\Sigma f} - \left(\frac{\Sigma fx}{\Sigma f} \right)^2}$$

Answer **all** the questions

- 1 (a) (i) Solve the inequality $\frac{7}{3} < \frac{x}{2} - \frac{x}{3} + 2 \leq 3$. [2]
- (ii) Represent your solution to (i) on a number line. [1]
- (iii) Write down the smallest prime number which satisfies $\frac{7}{3} < \frac{x}{2} - \frac{x}{3} + 2 \leq 3$. [1]
- (b) Express as a single fraction in its simplest form $\frac{4x-5}{2x^2-5x-3} - \frac{3}{2x+1}$. [3]
- (c) Simplify $\left(\frac{2p}{3q}\right)^2 \div \frac{\sqrt{q^5}}{\sqrt{p}}$. [2]
- (d) Solve the equation $\frac{x}{3-x} = \frac{3}{x-3} + 5$. [3]

2

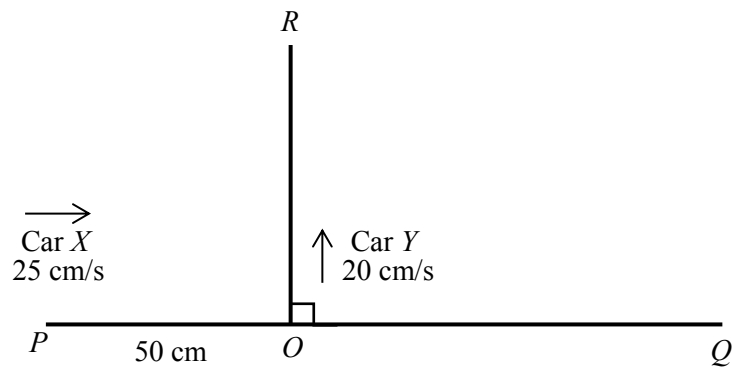

The diagram shows a toy car track $POQR$ with PQ perpendicular to OR and $OP = 50$ cm. Toy car X starts from P and travels towards Q at a constant speed of 25 cm/s. At the same time, another toy car Y starts from O and travels towards R at a constant speed of 20 cm/s.

- (a) Given that t is the time in seconds after the start of motion for both cars, write down expressions, in terms of t , for the distances of both cars from O when $t < 2$. [2]
- (b) Show that when the two toy cars are 35 cm apart,

$$41t^2 - 100t + 51 = 0.$$
 [3]
- (c) Solve the equation $41t^2 - 100t + 51 = 0$, leaving your answers correct to 2 decimal places. [3]
- (d) Hence, find the distance(s) of car Y from O , when the two cars are 35 cm apart. [2]
- A stone was detected lying at a point along the track between OQ .
- (e) Given that $OQ = 75$ cm, find the range of values of t for which car X will take to reach the stone. [2]

- 3 The diagram shows a line, L_1 , drawn through point $B(-2, 12)$ and another line, L_2 , drawn through point $C(0, 6)$. L_1 cuts the y -axis at D and L_2 is parallel to the x -axis. L_1 and L_2 intersect at A .

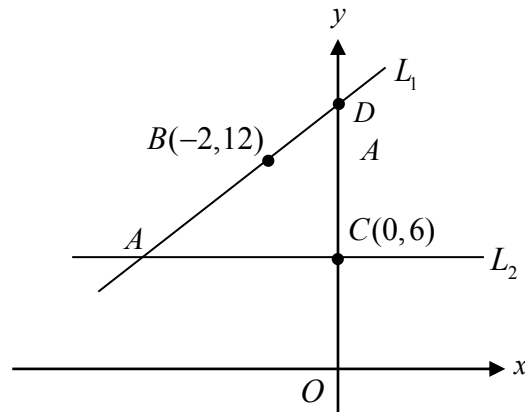

- (a) Write down the equation of the line AC . [1]
- (b) The gradient of L_1 is 2. Find the equation of L_1 . [2]
- (c) Find the coordinates of A . [2]
- (d) Find the area of triangle AOD , where O is the origin. [3]
- (e) A student draws another line $y = -3x + 1$ on the diagram and claims that it passes through the point B .
Is he correct? Justify your answer with calculations. [2]

- 4 The table below shows the distances of four planets from the Sun.

Planet	Distance from the Sun (km)
Pluto	5.91 billion
Earth	1.46×10^8
Uranus	2.88×10^9
Mercury	5.79×10^7

- (a) Write 5.91 billion in standard form. [1]
- (b) Calculate the distance between Earth and Mercury.
Give your answer in standard form. [1]
- (c) Show that Uranus is approximately 50 times further away from the Sun as compared to Mercury. [2]
- (d) Light travels 1 kilometre in 3.34×10^{-6} seconds.
How many seconds does light take to travel from the Sun to Earth? [2]

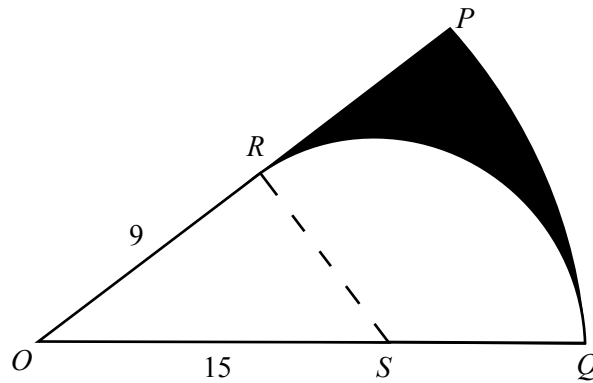

In the diagram, OPQ is the cross section of a wooden door stopper. PQ is an arc of a circle, centre O and RQ is an arc of another circle, centre S . $OR = 9$ cm, $OS = 15$ cm and OP is a tangent to arc RQ at R .

- (a) Show that angle $ROS = 0.927$ radians, correct to 3 significant figures. [2]

The wooden door stopper is 30 mm thick. The shaded region represents the portion that will be cut off to remove its sharp edge.

- (b) Calculate the perimeter of the shaded region. [5]
- (c) Calculate the volume of wood, in cm^3 , that needs to be cut off. [5]

- 6 A, B, C and D are four coastal guard posts on the Indian Ocean. C is 800 m due east of B and $AC = BC$. D is on line AC such that $CD = 300$ m and $BD = 600$ m.

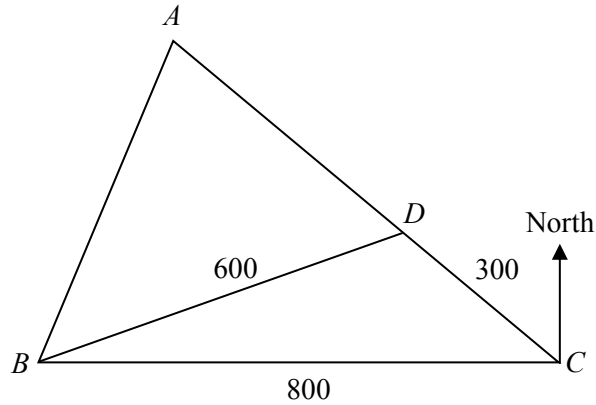

- (a) Calculate
- (i) angle BCD , [2]
 - (ii) the bearing of A from B . [2]
- (b) Find AB . [2]
- (c) A ship sailing along AC stops at a point X , which is nearest to B .
- (i) Find BX . [2]
 - (ii) The ship at point X sends a distress signal by shooting a red flame vertically up into the sky. It was spotted from point B when the red flame reached a height of 250 m.
Find the angle of elevation of the red flame from B . [2]
-

7 Answer the whole of this question on a sheet of graph paper.

A man sends a drone down a cliff next to the sea.

The height, h metres, of the drone above sea level t seconds after it is released can be modelled by the equation

$$h = 18 - 3t + 0.2t^2.$$

The table shows some corresponding values of t and h .

t	0	2	4	7	8	10	12	13
h	18	12.8	9.2	p	6.8	8	10.8	12.8

- (a) Find the value of p . [1]
- (b) Using a scale of 2 cm to represent 2 seconds, draw a horizontal t -axis for $0 \leq t \leq 13$.
Using a scale of 2 cm to represent 2 metres, draw a vertical h -axis for $0 \leq h \leq 18$.
On your axes, plot the points given in the table and join them with a smooth curve. [3]
- (c) Use your graph to estimate
- (i) the minimum height of the drone above the sea level, [1]
- (ii) the length of time at which the drone is less than 9 m above the sea level. [2]
- (d) (i) By drawing a tangent, find the gradient of the curve at $t = 10$. [2]
- (ii) Explain the significance of your answer in (d)(i). [1]
-

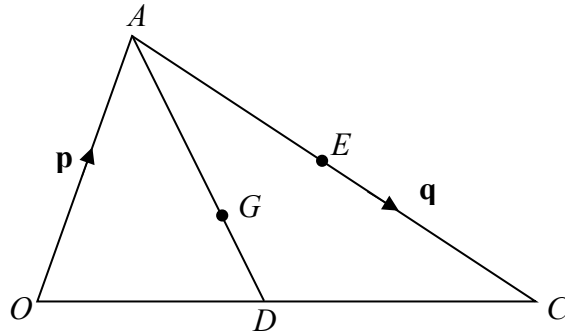

OAC is a triangle.

D and E are the midpoints of OC and AC respectively.

$\overrightarrow{OA} = \mathbf{p}$ and $\overrightarrow{AC} = \mathbf{q}$. G is a point along AD such that $AG : GD = 2 : 1$.

(a) Express, as simply as possible, in terms of \mathbf{p} and \mathbf{q}

(i) \overrightarrow{OE} , [1]

(ii) \overrightarrow{AD} , [2]

(iii) \overrightarrow{AG} , [2]

(iv) \overrightarrow{GE} . [2]

(b) Explain whether O , G and E are collinear. [2]

(c) If the area of triangle AOD is 14 cm^2 , find the area of triangle AOC . [2]

9 The table below summarises the heights of 200 trees in Rainforest A.

Height (h metres)	$0 \leq h < 10$	$10 \leq h < 20$	$20 \leq h < 30$	$30 \leq h < 40$	$40 \leq h < 50$
Frequency	10	25	80	65	20

- (a) Calculate an estimate of
- (i) the mean height, [1]
 - (ii) the standard deviation. [1]
- (b) The mean height for another 200 trees in Tropical Forest B was 20.1 metres and the standard deviation was 4.53 metres.
- Use this information to comment on two differences between the heights of the trees in the two forests. [2]
- (c) A tree was selected at random from Rainforest A.
Find, as a fraction in its lowest terms, the probability that its height is
- (i) 40 metres and above, [1]
 - (ii) below 30 metres. [1]
- (d) Two trees are selected at random.
Find the probability that **both** trees will be less than 20 metres.
Give your answer as a decimal correct to 3 significant figures. [2]
-

[Turn over

- 10 The Central Provident Fund (CPF) is a comprehensive social security savings scheme funded by contributions from **both** employers and employees. It is a key pillar of Singapore's social security system, and serves to meet the citizen's retirement, housing and healthcare needs.

The table shows the current monthly CPF contribution rates for Singapore Citizens and Permanent Residents.

Employee's age (years)	Monthly Contribution Rates from 1 Jan 2016 (for gross monthly income \geq \$750)		
	By Employer (% of income)	By Employee (% of income)	Total (% of income)
55 and below	17	20	37
Above 55 to 60	13	13	26
Above 60 to 65	9	7.5	16.5
Above 65	7.5	5	12.5

- (a) Brandon, a Singapore Citizen, aged 25 years, earns a gross monthly income of \$3650.

Calculate the **total** amount that contributes to Brandon's CPF account every month. [1]

- (b) The monthly CPF contribution goes into three accounts.

The table below provides information on the accounts and the ratio of contribution.

Account Type	Ratio of Contribution
Ordinary Account (OA) <i>Primarily for housing needs.</i>	0.6217
Special Account (SA) <i>Primarily for retirement needs.</i>	0.1621
Medisave Account (MA) <i>Primarily for healthcare needs.</i>	0.2162

Calculate the monthly amount that goes into Brandon's OA, giving your answer to the nearest cent. [1]

- (c) Brandon is planning to purchase a new 3-room flat.

He found the following information online.

Average Price of New Flats in 3 rd Quarter of 2018		
3-room	4-room	5-room/Executive
\$270000	\$350000	\$410000

***Administration Fees Payable for Purchase of a New Flat**

Type of fee	Amount
Option Fee <i>Option Fee is paid when you book your flat. It is based on the flat type that is booked.</i>	4/5-room and Executive Flat : \$2000 3-room : \$1000 2-room : \$1000
Downpayment	10% of purchase price of flat
Stamp Duty on Agreement for Lease <i>A duty levied on the legal recognition of certain documents. It is based on the purchase price of the flat.</i>	First \$180,000 : 1% Next \$180,000 : 2% Remaining Amount : 3%
Conveyancing fee for sale of flat <i>Legal costs involved when buying/selling a flat. It is based on the purchase price of the flat.</i>	First \$30,000 : \$0.90 per \$1000 Next \$30,000 : \$0.72 per \$1000 Remaining Amount : \$0.60 per \$1000 Please note that conveyancing fees are subjected to 7% GST.
Caveat registration fee <i>A caveat is lodged with the Singapore Land Authority to protect your interest in the flat. This is done by giving notice of your interest pending the Lease registration.</i>	\$64.45 (Inclusive of GST)
* These administration fees can be paid using funds in the CPF OA.	

Brandon wishes to pay the administration fees completely from his OA and has \$6000 in his OA.

Suggest the number of years that Brandon will need to accumulate sufficient money in his OA to pay for the administration fees.

[7]

Answer Key

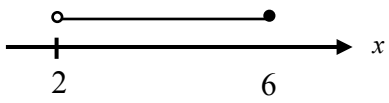
1	(a)(i)	$2 < x \leq 6$
	(a)(ii)	
	(a)(iii)	3
	(b)	$\frac{x+4}{(2x+1)(x-3)}$
	(c)	$\frac{4p^{\frac{5}{2}}}{9q^{\frac{9}{2}}}$
	(d)	$x = 2$
2	(a)	Car X : distance from $O = (50 - 25t)$ cm Car Y : distance from $O = 20t$ cm
	(b)	Show question
	(c)	$t = 1.71$ or $t = 0.73$
	(d)	When $t = 0.73$, distance of Y from $O = 14.5$ cm (3 sig.fig) When $t = 1.71$, distance of Y from $O = 34.3$ cm (3 sig.fig)
	(e)	$2 < t < 5$
3	(a)	$y = 6$
	(b)	$y = 2x + 16$
	(c)	$A(-5, 6)$
	(d)	40 units ²
	(e)	Since $B(-2, 12)$ does not satisfy the equation $y = -3x + 1$, the point B does not lie on the line $y = -3x + 1$. The student is not correct.
4	(a)	5.91×10^9
	(b)	8.81×10^7
	(c)	Show question
	(d)	487.64 s
5	(a)	Show question
	(b)	73.0 cm (3 s.f.)
	(c)	312 cm ³
6	(a)(i)	39.6°
	(a)(ii)	019.8°
	(b)	542 m (3 s.f.)
	(c)(i)	510 m (3 s.f.)
	(c)(ii)	26.1° (1 d.p.)
7	(a)	$p = 6.8$
	(c)(i)	6.7 m
	(c)(ii)	6.6 s
	(d)(i)	0.938
	(d)(ii)	It represents the speed at which the drone is rising at $t = 10$, which is 0.938 m/s.

8	(a)(i)	$\frac{p+\frac{1}{2}q}{\sim \quad \sim}$
	(a)(ii)	$-\frac{1}{2}p+\frac{1}{2}q$
	(a)(iii)	$-\frac{1}{3}p+\frac{1}{3}q$
	(a)(iv)	$\frac{1}{3}p+\frac{1}{6}q$
	(b)	O, G and E are collinear since $\overrightarrow{GE} = \frac{1}{3}\overrightarrow{OE}$ with a common point E .
	(c)	28 cm ²
9	(a)(i)	28 m
	(a)(ii)	9.80 m
	(b)	The trees in Rainforest A are generally taller as their mean height of 28 m is higher than 20.1 m of Tropical Forest B. The heights of trees in Rainforest A are generally more widespread as they have a higher standard deviation of 9.80 as compared to Tropical Forest B of 4.53 m.
	(c)(i)	$\frac{1}{10}$
	(c)(ii)	$\frac{23}{40}$
	(d)	0.0299 (3 s.f.)
10	(a)	\$1350.50
	(b)	\$839.61 (nearest cents)
	(c)	Brandon will need about 3 years to accumulate sufficient money.

Name:	Class:	Class Register Number:
-------	--------	------------------------



中正中学

CHUNG CHENG HIGH SCHOOL (MAIN)

Chung Cheng High School Chung Cheng High School Chung Cheng High School Chung Cheng High School Chung Cheng High School
Chung Cheng High School Chung Cheng High School Chung Cheng High School Chung Cheng High School Chung Cheng High School
Chung Cheng High School Chung Cheng High School Chung Cheng High School Chung Cheng High School Chung Cheng High School
Chung Cheng High School Chung Cheng High School Chung Cheng High School Chung Cheng High School Chung Cheng High School
Chung Cheng High School Chung Cheng High School Chung Cheng High School Chung Cheng High School Chung Cheng High School

**PRELIMINARY EXAMINATION 2018
SECONDARY 4**

MATHEMATICS

4048/02

Paper 2

13 September 2018

2 hours 30 minutes

SOLUTION FOR STUDENTS

This document consists of **21** printed pages and **0** blank page.

1 (a)(i)

$$\begin{aligned}\frac{7}{3} &< \frac{x}{2} - \frac{x}{3} + 2 \leq 3 \\ \frac{7}{3} - 2 &< \frac{x}{2} - \frac{x}{3} \leq 3 - 2 \\ \frac{1}{3} &< \frac{x}{6} \leq 1 \\ 2 &< x \leq 6\end{aligned}$$

(a)(ii)

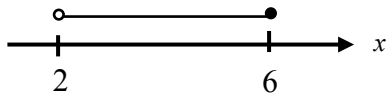

(a)(iii) 3

(b)

$$\begin{aligned}\frac{4x-5}{2x^2-5x-3} - \frac{3}{2x+1} \\ = \frac{4x-5}{(2x+1)(x-3)} - \frac{3}{2x+1} \\ = \frac{4x-5}{(2x+1)(x-3)} - \frac{3(x-3)}{(2x+1)(x-3)} \\ = \frac{4x-5-3x+9}{(2x+1)(x-3)} \\ = \frac{x+4}{(2x+1)(x-3)}\end{aligned}$$

(c)

$$\begin{aligned}\left(\frac{2p}{3q}\right)^2 \div \frac{\sqrt{q^5}}{\sqrt{p}} \\ = \frac{4p^2}{9q^2} \times \frac{\sqrt{p}}{\sqrt{q^5}} \\ = \frac{4p^2}{9q^2} \times \frac{p^{\frac{1}{2}}}{q^{\frac{5}{2}}} \\ = \frac{4p^{\frac{5}{2}}}{9q^{\frac{5}{2}}}\end{aligned}$$

(d)

$$\begin{aligned} \frac{x}{3-x} &= \frac{3}{x-3} + 5 \\ -\frac{x}{x-3} &= \frac{3}{x-3} + 5 \\ -5 &= \frac{3}{x-3} + \frac{x}{x-3} \\ -5 &= \frac{3+x}{x-3} \\ -5(x-3) &= 3+x \\ -5x+15 &= 3+x \\ 6x &= 12 \\ x &= 2 \end{aligned}$$

2 (a) Car X : distance from $O = (50 - 25t)$ cmCar Y : distance from $O = 20t$ cm

(b)

$$\begin{aligned} (50 - 25t)^2 + (20t)^2 &= 35^2 \\ 2500 - 2500t + 625t^2 + 400t^2 &= 1225 \\ 1025t^2 - 2500t + 1275 &= 0 \\ (\div 25) \quad 41t^2 - 100t + 51 &= 0 \text{ (shown)} \end{aligned}$$

(c)

$$\begin{aligned} 41t^2 - 100t + 51 &= 0 \\ t &= \frac{-(-100) \pm \sqrt{(-100)^2 - 4(41)(51)}}{2(41)} \\ &= \frac{100 \pm \sqrt{1636}}{82} \\ t &= 1.7127... \quad \text{or} \quad t = 0.72625... \\ &= 1.71 \text{ (2 dec.pl)} \quad \quad = 0.73 \text{ (2 dec.pl)} \end{aligned}$$

(d)

When $t = 0.76262\dots$

$$\begin{aligned}\text{Distance of } Y \text{ from } O &= 20(0.76262\dots) \\ &= 14.525\dots \\ &= 14.5 \text{ cm (3 sig. fig)}\end{aligned}$$

When $t = 1.7127\dots$

$$\begin{aligned}\text{Distance of } Y \text{ from } O &= 20(1.7127\dots) \\ &= 34.255\dots \\ &= 34.3 \text{ cm (3 sig. fig)}\end{aligned}$$

(e)

$$\begin{aligned}\text{Time to reach } O &= \frac{50}{25} \\ &= 2\end{aligned}$$

$$\begin{aligned}\text{Time to reach } Q &= \frac{75}{25} \\ &= 3\end{aligned}$$

$$2 < t < 5$$

3 (a) $y = 6$

(b)

$$y = 2x + c$$

subst $(-2, 12)$

$$12 = 2(-2) + c$$

$$12 = -4 + c$$

$$c = 16$$

$$\therefore L_1 : y = 2x + 16$$

(c)

$$y = 6 \text{ --- (1)}$$

$$y = 2x + 16 \text{ --- (2)}$$

subst (1) into (2),

$$2x + 16 = 6$$

$$2x = -10$$

$$x = -5$$

$$y = 6$$

$$\therefore A(-5, 6)$$

(d)

$$L_1 : y = 2x + 16$$

when $x = 0, y = 16$ Area of triangle AOD

$$= \frac{1}{2} \times 16 \times 5$$

$$= 40 \text{ units}^2$$

(e)

subst $x = -2$ into $y = -3x + 1$

$$y = -3(-2) + 1$$

$$= 7 \neq 12$$

Since $B(-2, 12)$ does not satisfy the equation $y = -3x + 1$,
the point B does not lie on the line $y = -3x + 1$.

The student is not correct.

4 (a) $5.91 \text{ billion} = 5.91 \times 10^9$

(b)

$$1.46 \times 10^8 - 5.79 \times 10^7$$

$$= 8.81 \times 10^7$$

(c)

$$\frac{2.88 \times 10^9}{5.79 \times 10^7} = 49.7409\dots$$

$$= 50 \text{ (2 sig.fig) (Shown)}$$

(d)

Time taken

$$= 1.46 \times 10^8 \times 3.34 \times 10^{-6}$$

$$= 487.64 \text{ s}$$

5 (a)

$$\angle ORS = \frac{\pi}{2} \text{ (tangent perpendicular to radius)}$$

$$\cos \angle ROS = \frac{9}{15}$$

$$\begin{aligned} \angle ROS &= \cos^{-1}\left(\frac{9}{15}\right) \\ &= 0.927295\dots \\ &= 0.927 \text{ (3 sig.fig)} \end{aligned}$$

(b)

$$\begin{aligned} RS &= \sqrt{15^2 - 9^2} \\ &= \sqrt{144} \\ &= 12 \text{ cm} \end{aligned}$$

$$\begin{aligned} OP &= OQ \\ &= 15 + 12 \\ &= 27 \text{ cm} \end{aligned}$$

$$\begin{aligned} RP &= 27 - 9 \\ &= 18 \text{ cm} \end{aligned}$$

$$\begin{aligned} \angle RSQ &= \frac{\pi}{2} + 0.927295\dots \\ &= 2.49809\dots \end{aligned}$$

$$\begin{aligned} \text{Arc length } RQ &= 12(2.49809\dots) \\ &= 29.9770\dots\text{cm} \end{aligned}$$

$$\begin{aligned} \text{Arc length } PQ &= 27(0.927295\dots) \\ &= 25.036965\dots\text{cm} \end{aligned}$$

$$\begin{aligned} \text{Perimeter} &= 18 + 29.97709 + 25.036965 \\ &= 73.0140\dots \\ &= 73.0 \text{ cm (3 sig.fig)} \end{aligned}$$

(c)

$$\begin{aligned}\text{Area of triangle } ROS &= \frac{1}{2} \times 9 \times 12 \\ &= 54 \text{ cm}^2\end{aligned}$$

$$\begin{aligned}\text{Area of sector } RSQ &= \frac{1}{2} \times (12)^2 \times 2.49809\dots \\ &= 179.86259\dots \text{ cm}^2\end{aligned}$$

$$\begin{aligned}\text{Area of sector } OPQ &= \frac{1}{2} \times (15+12)^2 \times \left[\cos^{-1} \left(\frac{9}{15} \right) \right] \\ &= 337.999\dots \text{ cm}^2\end{aligned}$$

$$\begin{aligned}\text{Area of shaded region} &= 337.999\dots - 54 - 179.86259 \\ &= 104.136517\dots \text{ cm}^2\end{aligned}$$

Volume of wood to be cut off

$$\begin{aligned}&= 104.136517\dots \times 3 \\ &= 312.4095\dots \\ &= 312 \text{ cm}^3 \text{ (3 sig.fig)}\end{aligned}$$

6 (a) (i)

$$\begin{aligned}600^2 &= 800^2 + 300^2 - 2(800)(300)\cos \angle BCD \\ 360000 &= 730000 - 480000 \cos \angle BCD \\ \cos \angle BCD &= \frac{360000 - 730000}{-480000} \\ \angle BCD &= 39.571219\dots \\ &= 39.6^\circ \text{ (1 dec.pl)}\end{aligned}$$

(ii)

 $AC = BC$ (given) $\angle ABC = \angle CAB$

$$\begin{aligned}&= \frac{180^\circ - 39.571219^\circ}{2} \\ &= 70.21439\dots^\circ\end{aligned}$$

$$\begin{aligned}\angle N_1BA &= 90^\circ - 70.21439\dots^\circ \\ &= 19.7856\dots^\circ \\ &= 19.8^\circ \text{ (1 dec.pl)}\end{aligned}$$

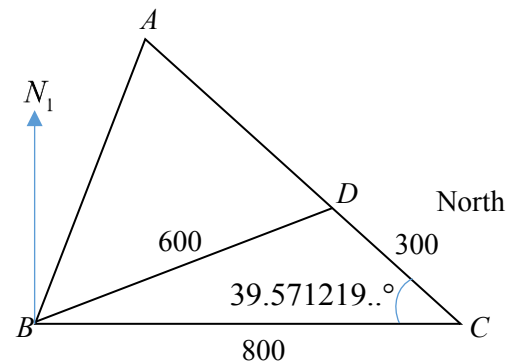
Bearing of A from $B = 019.8^\circ$ (1 dec.pl)

(b)

$$\frac{800}{\sin \angle BAC} = \frac{AB}{\sin \angle DCB}$$

$$\frac{800}{\sin 70.21439^\circ} = \frac{AB}{\sin 39.57129^\circ}$$

$$AB = \frac{800}{\sin 70.21439^\circ} \times \sin 39.57129^\circ$$

$$= 541.60336\dots$$

$$= 542 \text{ m (3 sig.fig)}$$

Using cosine rule

$$AB^2 = 800^2 + 800^2 - 2(800)(800) \cos 39.57129^\circ$$

$$AB^2 = 293333.32\dots$$

$$AB = 541.60255\dots$$

$$= 542 \text{ m (3 sig.fig)}$$

(c)(i)

$$\frac{BX}{AB} = \sin 70.2143\dots^\circ$$

$$BX = 541.60336\dots \times \sin 70.2143\dots^\circ$$

$$= 509.629\dots$$

$$= 510 \text{ m (3 sig.fig)}$$

(ii)

Let the top of the flame be F

$$\tan \angle FBX = \frac{250}{509.629\dots}$$

$$\angle FBX = 26.1303\dots^\circ$$

$$= 26.1^\circ \text{ (1 dec.pl)}$$

7 (a)

$$p = 6.8$$

(b) All 8 points plotted
Smooth curve through plotted points

(c)(i) Minimum height = 6.7 m

(ii) length of time = 10.8 – 4.2
= 6.6 s

(d)(i)

$$\text{gradient} = \frac{11-5}{13.2-6.8}$$

$$= 0.938$$

(ii) It represents the speed at which the drone is rising at $t = 10$, which is 0.938 m/s.

8 (a)(i)

$$\begin{aligned}\overrightarrow{OE} &= \overrightarrow{OA} + \overrightarrow{AE} \\ &= \underset{\sim}{p} + \frac{1}{2} \underset{\sim}{q}\end{aligned}$$

(ii)

$$\begin{aligned}\overrightarrow{AD} &= \overrightarrow{AO} + \overrightarrow{OD} \\ &= -\underset{\sim}{p} + \frac{1}{2} \overrightarrow{OC} \\ &= -\underset{\sim}{p} + \frac{1}{2} \left(\underset{\sim}{p} + \underset{\sim}{q} \right) \\ &= -\underset{\sim}{p} + \frac{1}{2} \underset{\sim}{p} + \frac{1}{2} \underset{\sim}{q} \\ &= -\frac{1}{2} \underset{\sim}{p} + \frac{1}{2} \underset{\sim}{q}\end{aligned}$$

(iii)

$$\begin{aligned}\overrightarrow{AG} &= \frac{2}{3} \overrightarrow{AD} \\ &= \frac{2}{3} \left(-\frac{1}{2} \underset{\sim}{p} + \frac{1}{2} \underset{\sim}{q} \right) \\ &= -\frac{1}{3} \underset{\sim}{p} + \frac{1}{3} \underset{\sim}{q}\end{aligned}$$

(iv)

$$\begin{aligned}\overrightarrow{GE} &= \overrightarrow{GA} + \overrightarrow{AE} \\ &= \frac{1}{3} \underset{\sim}{p} - \frac{1}{3} \underset{\sim}{q} + \frac{1}{2} \underset{\sim}{q} \\ &= \frac{1}{3} \underset{\sim}{p} + \frac{1}{6} \underset{\sim}{q}\end{aligned}$$

(b)

$$\begin{aligned}\overrightarrow{GE} &= \frac{1}{3} \underset{\sim}{p} + \frac{1}{6} \underset{\sim}{q} \\ &= \frac{1}{3} \left(\underset{\sim}{p} + \frac{1}{2} \underset{\sim}{q} \right) \\ &= \frac{1}{3} \overrightarrow{OE}\end{aligned}$$

O, G and E are collinear since $\overrightarrow{GE} = \frac{1}{3} \overrightarrow{OE}$ with a common point E .

(c)

Both triangles have common height,

$$\frac{\text{Area of triangle } AOD}{\text{Area of triangle } AOC} = \frac{1}{2}$$

$$\frac{14}{\text{Area of triangle } AOC} = \frac{1}{2}$$

$$\begin{aligned} \text{Area of triangle } AOC &= 14 \times 2 \\ &= 28 \text{ cm}^2 \end{aligned}$$

- 9 (a) (i) 28 m
(ii) 9.80 m

(b) The trees in Rainforest A are generally taller as their mean height of 28 m is higher than 20.1 m of Tropical Forest B.

The heights of trees in Rainforest A are generally **more widespread** as they have a higher standard deviation of 9.80 as compared to Tropical Forest B of 4.53 m.

(c) (i)

$$\begin{aligned} P(\text{height} \geq 40 \text{ m}) &= \frac{20}{200} \\ &= \frac{1}{10} \end{aligned}$$

(ii)

$$\begin{aligned} P(\text{height} < 30 \text{ m}) &= \frac{80 + 25 + 10}{200} \\ &= \frac{23}{40} \end{aligned}$$

(d)

$$\begin{aligned} P(\text{both trees} < 20 \text{ m}) &= \frac{35}{200} \times \frac{34}{199} \\ &= 0.0299 \text{ (3 sig. fig)} \end{aligned}$$

- 10 (a) monthly contribution

$$= \$ \frac{37}{100} \times 3650$$

$$= \$1350.50$$

- (b)

Amount in OA

$$= \$ 0.6217 \times 1350.50$$

$$= \$839.605\dots$$

$$= \$839.61 \text{ (nearest cents)}$$

- (c)

Administrative Fees for 3 room flat

(1) option fee : \$1000

$$(2) \text{ Downpayment} = \$ \frac{10}{100} \times 270\,000$$

$$= \$27\,000$$

$$(3) \text{ Stamp duty} = \$1800 + \left(\frac{2}{100} \times \$90\,000 \right)$$

$$= \$3600$$

$$(4) \text{ Conveyancing fee : First } \$30000 : \$0.90 \times 30 = \$27$$

$$\text{Next } \$30000 : \$0.72 \times 30 = \$21.60$$

$$\text{Remaining amount : } \$0.60 \times 210 = \$126$$

$$\text{Total including GST} = (\$27 + \$21.60 + \$126) \times 1.07$$

$$= \$186.82$$

$$\text{Total amount payable} = \$1000 + \$27\,000 + \$3600 + \$186.82 + \$64.45$$

$$= \$31851.27$$

$$\text{Amount that Brandon needs} = \$31851.27 - \$6000$$

$$= \$25851.27$$

Number of years needed

$$= \left(\frac{\$25851.27}{\$839.61} \right) \div 12$$

$$= 2.565\dots \text{ years}$$

$$\approx 3 \text{ years}$$

Brandon will need about 3 years to accumulate sufficient money.
