

NAME: _____ ()

CLASS: _____



FAIRFIELD METHODIST SCHOOL (SECONDARY)

**PRELIMINARY EXAMINATION 2019
SECONDARY 4 EXPRESS**

ADDITIONAL MATHEMATICS

4047/01

Paper 1

Date: 30 August 2019

Duration: 2 hours

READ THESE INSTRUCTIONS FIRST

Write your name, index number and class on all the work you hand in.
Write in dark blue or black pen.
You may use a pencil for any diagrams or graphs.
Do not use staples, paper clips, highlighters, glue or correction fluid.

Answer all questions.

Write your answers on the space provided.

Give non-exact numerical answers correct to 3 significant figures, or 1 decimal place in the case of angles in degrees, unless a different level of accuracy is specified in the question.

The use of a scientific calculator is expected, where appropriate.

You are reminded of the need for clear presentation in your answers.

At the end of the examination, fasten all your work securely together.

The number of marks is given in brackets [] at the end of each question or part question.

The total number of marks for this paper is 80.

For Examiner's Use	
Paper 1	/ 80

Setter: Ms Lim Chee Chin and Mr Wilson Ho

This paper consists of 22 printed pages.

Name: _____ ()

Class: _____

Mathematical Formulae

1. ALGEBRA

Quadratic Equation

For the equation $ax^2 + bx + c = 0$,

$$x = \frac{-b \pm \sqrt{b^2 - 4ac}}{2a}$$

Binomial expansion

$$(a+b)^n = a^n + \binom{n}{1}a^{n-1}b + \binom{n}{2}a^{n-2}b^2 + \dots + \binom{n}{r}a^{n-r}b^r + \dots + b^n,$$

where n is a positive integer and $\binom{n}{r} = \frac{n!}{r!(n-r)!} = \frac{n(n-1)\dots(n-r+1)}{r!}$

2. TRIGONOMETRY

Identities

$$\sin^2 A + \cos^2 A = 1$$

$$\sec^2 A = 1 + \tan^2 A$$

$$\operatorname{cosec}^2 A = 1 + \cot^2 A$$

$$\sin(A \pm B) = \sin A \cos B \pm \cos A \sin B$$

$$\cos(A \pm B) = \cos A \cos B \mp \sin A \sin B$$

$$\tan(A \pm B) = \frac{\tan A \pm \tan B}{1 \mp \tan A \tan B}$$

$$\sin 2A = 2 \sin A \cos A$$

$$\cos 2A = \cos^2 A - \sin^2 A = 2 \cos^2 A - 1 = 1 - 2 \sin^2 A$$

$$\tan 2A = \frac{2 \tan A}{1 - \tan^2 A}$$

Formulae for $\triangle ABC$

$$\frac{a}{\sin A} = \frac{b}{\sin B} = \frac{c}{\sin C}$$

$$a^2 = b^2 + c^2 - 2bc \cos A$$

$$\Delta = \frac{1}{2} ab \sin C$$

Name: _____ ()

Class: _____

1. Solve the equation $5 \sin y \cos y - 3 \cos^2 y = 0$ for $0^\circ < y < 360^\circ$.

[4]

Name: _____ () Class: _____

- 2 The figure shows part of a straight line graph obtained by plotting $\ln y$ against x^2 , together with the coordinates of a point $(\sqrt{3}, 5)$ on the line. Express y as a function of x . [4]

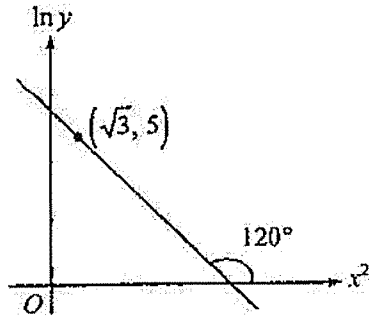

Name: _____ () Class: _____

- 3 The diagram shows part of the curve $y = \frac{1}{x}$ ($x > 0$) and $y^2 = x$ which intersect at A . Calculate the area of the shaded region. [5]

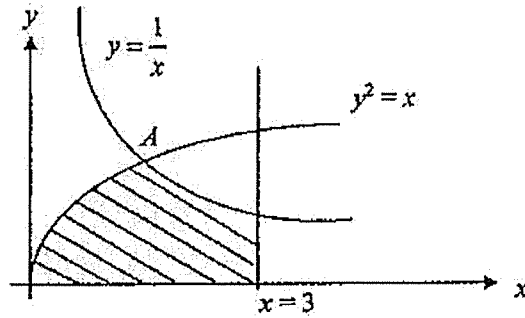

Name: _____ ()

Class: _____

4

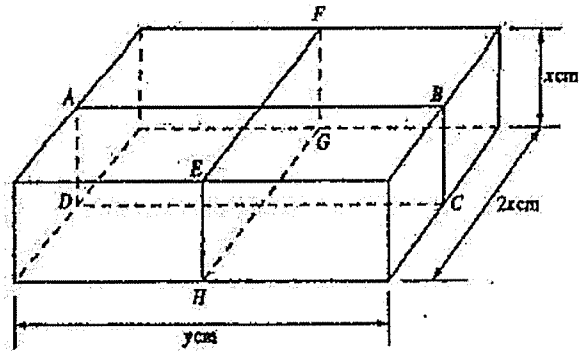

The diagram shows a package in the shape of a rectangular block whose sides are of length x cm, $2x$ cm and y cm. The package is secured by two pieces of ribbon, $ABCD A$ and $EFGHE$, whose total length is 312 cm. The volume of the package is V cm³.

(i) Show that $V = 312x^2 - 8x^3$.

[2]

Name: _____ () Class: _____

4 (ii) Given that x can vary, find the dimensions of the block that make V a maximum. [3]

Name: _____ ()

Class: _____

5

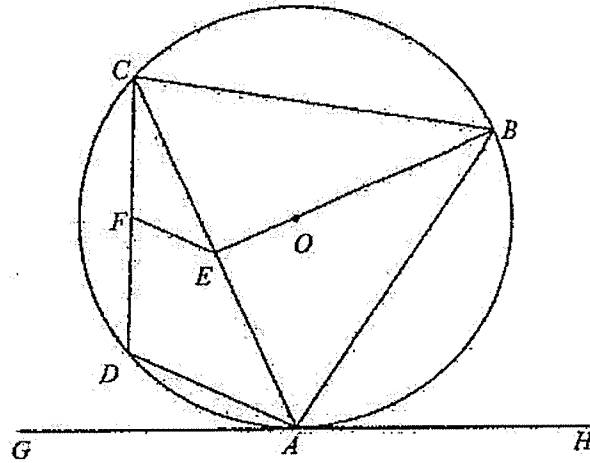

The diagram shows a circle with centre O , passing through points A , B , C and D . GAH is a tangent to the circle at point A . It is given that $BA = BC$ and $FC = FD$. It is also given that E is a point on AC such that BE is perpendicular to AC and BE passes through O .

- (i) Show that AB bisects $\angle CAH$. [3]

Name: _____ ()

Class: _____

5 (ii) Show that FE is parallel to DA .

[3]

Name: _____ () Class: _____

- 6 The diagram shows part of the curve $y = |ax^2 + bx + c|$, where $a > 0$. The curve touches the x -axis at $A(r, 0)$ and $B(1, 0)$ and has a maximum point at $(-2, 27)$.

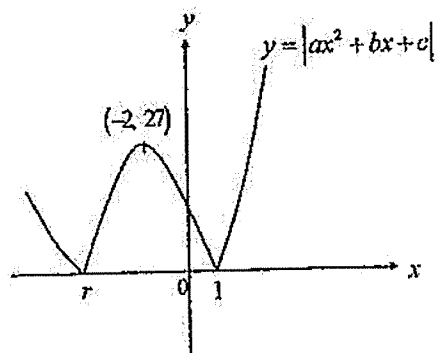

- (i) Show that $r = -5$. [1]

- (ii) Determine the value of a , b and c . [4]

- (iii) State the value of q for which the line $y = q$ intersects the curve at exactly 3 points. [1]

Name: _____ () Class: _____

- 7 (a) Without using a calculator, show that $\operatorname{cosec} 105^\circ = \sqrt{2}(\sqrt{3}-1)$. [3]

Name: _____ ()

Class: _____

7 (b) Prove that $\tan x + \cot x = 2 \operatorname{cosec} 2x$.

[4]

Name: _____ () Class: _____

8 The curve $y = e^{\frac{1}{x}} + ke^{-\frac{1}{x}}$, where k is a constant has a stationary point at $x = \ln 3$.

(i) Show that the value of $k = 3$.

[3]

Name: _____ ()

Class: _____

- 8 (ii) Hence, find the y -coordinate of the stationary point in the form $a\sqrt{b}$ where a and b are integers, and determine the nature of the stationary point. [4]

Name: _____ ()

Class: _____

- 9 (a) The coefficient of x^{-2} in the expansion of $\left(1 - \frac{3}{x}\right)^n$, where n is a positive integer, is 819.

Find the value of n .

[4]

Name: _____ () Class: _____

- 9 (b) Write down, and simplify, the first 4 terms in the expansion of $(1+p)^9$ in ascending powers of p . Hence, find the coefficient of x^3 in the expansion of $(1-x-2x^2)^9$. [4]

Name: _____ () Class: _____

10 The equation of the curve C is $2y = x^2 + 4$. The equation of the line L is $y = 3x - k$, where k is an integer.

(i) Find the largest value of the integer k for which L intersects C . [4]

Name: _____ () Class: _____

- 10 (ii) In the case where $k = -2$, show that the line joining the points of intersection of L and C' is bisected by the line $y = 2x + 5$. [4]

Name: _____ () Class: _____

- 11 (a) A curve is such that $\frac{dy}{dx} = \frac{3k}{(x-4)^2}$. The equation of the normal to the curve at the point where the curve crosses the x -axis is given by $y = 2x + 4$.
Find the value of k and hence find the equation of the curve. [5]

Name: _____ ()

Class: _____

11 (b) Show that $\frac{d}{dx}(\cos^3 x - 3\cos x) = 3\sin^3 x$.

Hence, evaluate $\int_{0.5}^1 (3\sin^3 x - 2\sin x) dx$.

[5]

Name: _____ () Class: _____

12 The line $x = 17$ is a tangent to a circle and the points $A(1, 9)$ and $B(1, -7)$ lie on the circle.

(i) Show that the radius of the circle is 10 units. [4]

Name: _____ ()

Class: _____

12 (ii) State the coordinates of the centre of the circle.

[1]

(iii) Write down the equation of the circle in the form $x^2 + y^2 + px + qy + r = 0$.

[2]

(iv) The circle is reflected along the line $y = -1$. Determine whether the point (3, 10) lies on or inside or outside the reflected circle.

[3]

~ End of Paper ~

Mathematical Formulae**I. ALGEBRA***Quadratic Equation*For the equation $ax^2 + bx + c = 0$,

$$x = \frac{-b \pm \sqrt{b^2 - 4ac}}{2a}$$

Binomial expansion

$$(a+b)^n = a^n + \binom{n}{1}a^{n-1}b + \binom{n}{2}a^{n-2}b^2 + \dots + \binom{n}{r}a^{n-r}b^r + \dots + b^n$$

where n is a positive integer and $\binom{n}{r} = \frac{n!}{r!(n-r)!} = \frac{n(n-1)\dots(n-r+1)}{r!}$

2. TRIGONOMETRY*Identities*

$$\sin^2 A + \cos^2 A = 1$$

$$\sec^2 A = 1 + \tan^2 A$$

$$\operatorname{cosec}^2 A = 1 + \cot^2 A$$

$$\sin(A \pm B) = \sin A \cos B \pm \cos A \sin B$$

$$\cos(A \pm B) = \cos A \cos B \mp \sin A \sin B$$

$$\tan(A \pm B) = \frac{\tan A \pm \tan B}{1 \mp \tan A \tan B}$$

$$\sin 2A = 2 \sin A \cos A$$

$$\cos 2A = \cos^2 A - \sin^2 A = 2 \cos^2 A - 1 = 1 - 2 \sin^2 A$$

$$\tan 2A = \frac{2 \tan A}{1 - \tan^2 A}$$

Formulae for $\triangle ABC$

$$\frac{a}{\sin A} = \frac{b}{\sin B} = \frac{c}{\sin C}$$

$$a^2 = b^2 + c^2 - 2bc \cos A$$

$$\Delta = \frac{1}{2} ab \sin C$$

Name: _____ ()

Class: _____

- 1 A cuboid has a square base of side $(5 - \sqrt{12})$ cm and a volume of $(14 - \sqrt{27})$ cm³. Find the height of the cuboid in the form $(a + b\sqrt{3})$ cm, where a and b are integers.

[4]

Name: _____ () Class: _____

- 2 A flock of 20 Yellow-crested Cockatoos was introduced to an island where it is not a native species. The population of Cockatoos is predicted to increase so that after a period of t

years, the population, P , is given by $P = \frac{k}{1 + 4e^{-0.14t}}$, where k is a constant.

- (i) Show that $k = 100$.

[1]

- (ii) Find the number of Cockatoos present after 10 years. Give your answer correct to the nearest integer.

[2]

- (iii) Find the value of P as t becomes very large. Explain the significance of this value. [2]

Name: _____ ()

Class: _____

3

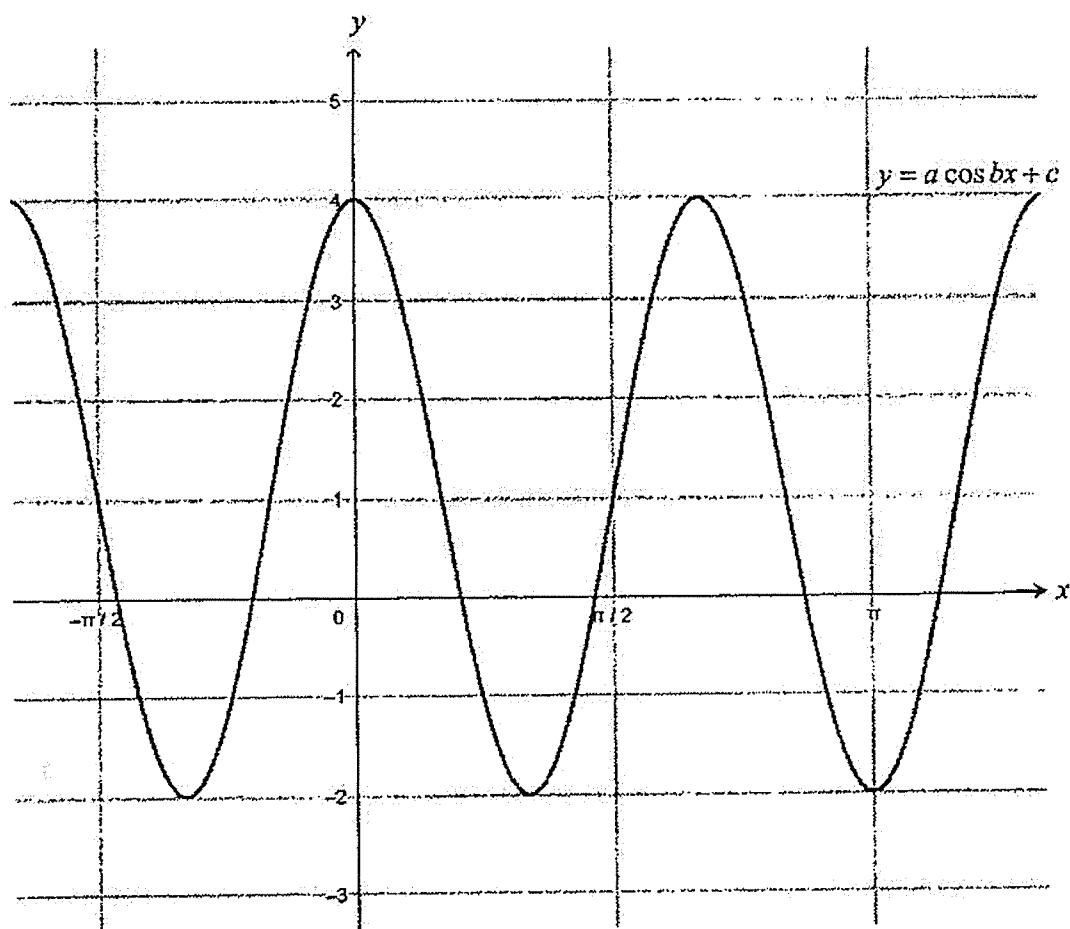

The diagram below shows the graph of $y = a \cos bx + c$, where a , b and c are integers.

Name: _____ ()

Class: _____

- (i) From the graph above, find the values of a , b and c .

[3]

- (ii) Sketch on the same diagram, the graph of $y = 1 - 2\sin x$ for the interval $0 \leq x \leq \pi$.

State the number of solutions in the interval $0 \leq x \leq \pi$ of the equation

$$a \cos bx + c = 1 - 2\sin x$$

[3]

Name: _____ ()

Class: _____

4 A curve has the equation $y = \ln\left(\frac{6+2x}{5x-3}\right)$.

(i) Express $\frac{dy}{dx}$ in the form $\frac{k}{(3+x)(5x-3)}$, where k is a constant.

[4]

4 (ii) Show that y is a decreasing function for

$x > \frac{3}{5}$. [2]

Name: _____ ()

Class: _____

5 The roots of the equation $x^2 - 2x + 7 = 0$ are α and β .

(i) Show that

$$\alpha^3 + \beta^3 = -34.$$

[4]

Name: _____ () Class: _____

- 5 (ii) Given that the roots of $x^2 + ax + b = 0$ are $\frac{1}{\alpha^3} + 2$ and $\frac{1}{\beta^3} + 2$, find the values of a and b where a and b are constants.

[4]

Name: _____ ()

Class: _____

6 Solution to this question by accurate drawing will not be accepted.

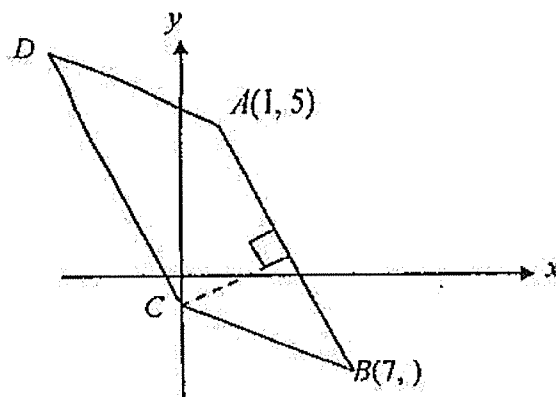

The figure above shows a sketch of a quadrilateral $ABCD$. The coordinates of A and B are $(1, 5)$ and $(7, -3)$ respectively.

(i) Find the gradient of the line perpendicular to AB .

[2]

(ii) If the perpendicular bisector of AB cuts the y -axis at C , find the coordinates of C .

[3]

Name: _____ ()

Class: _____

6 (iii) Find the coordinates of D if $ABCD$ is a parallelogram.

[1]

(iv) Calculate the area of the parallelogram $ABCD$.

[2]

Name: _____ ()

Class: _____

- 7 (a) Given that $\frac{a^{x+1}}{b^{5-x}} \times \frac{b^{2y}}{a^{2x-2}} = ab^6$, find the value of x and of y .

[4]

Name: _____ ()

Class: _____

7 (b) Solve the equation $3^{2x-2} - 6(3^{x-1}) + 5 = 0$

[4]

Name: _____ ()

Class: _____

- 7 (c) Given that $\log_3 a = p$, $\log_{27} b = q$ and $\frac{a}{b} = 3^c$, express c in terms of p and q .

[4]

Name: _____ () Class: _____

8 The cubic polynomial $f(x) = 6x^3 + hx^2 + kx - 18$ is exactly divisible by $3x - 2$ and leaves a remainder of 11 when it is divided by $x - 1$.

(i) Show that $h = -4$ and $k = 27$. [4]

Name: _____ ()

Class: _____

- 8 (ii) Hence, factorise $f(x)$ completely. [2]

- 8 (iii) Using the results in (ii), express $\frac{-8x^2 - 7x + 28}{f(x)}$ in partial fractions. [4]

9

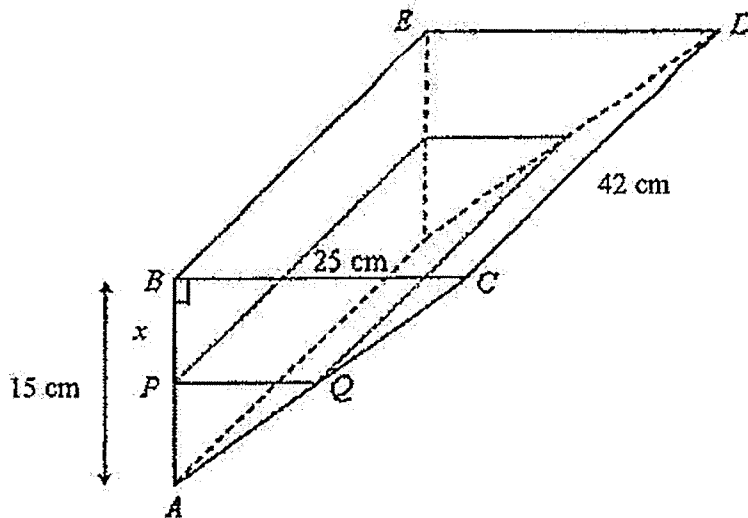

A trough has the shape of a triangular prism as shown in the diagram. The cross-section is a right-angled triangle with a height of 15 cm. The open top $BCDE$ is horizontal and rectangular in shape with $BC = 25$ cm and $BE = 42$ cm.

The trough is being filled with water. At time t seconds after filling starts, the surface of water is x cm from the open top (i.e. $BP = x$ cm), with PQ indicating the level reached.

Given that the water is flowing into the trough at a rate of $45 \text{ cm}^3/\text{s}$,

(i) find PQ in terms of x ,

[2]

9 (ii) show that the volume, V , of water in the trough at time t is $35(15-x)^2$,

[2]

Name: _____ ()

Class: _____

(iii) find the rate at which x is changing when $x = 8$.

[3]

10 (i) Express $\frac{4x}{2x-1}$ in the form $a + \frac{b}{2x-1}$, where a and b are integers.

[2]

(ii) Differentiate $2x \ln(2x-1)$ with respect to x .

[3]

Name: _____ () Class: _____

10. (iii) Using the results in part (i) and part (ii), determine $\int \ln(2x-1) dx$.

[4]

Name: _____ ()

Class: _____

- 11 In the diagram below, $ABCD$ is a rectangle. A line through A makes an angle of θ with AB and intersects DC and BC produced at F and G respectively. $AF = 9$ cm, $FG = 3$ cm and θ is acute.

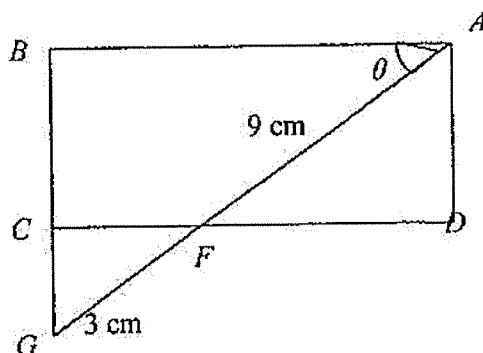

- (i) Show that the perimeter, P cm, of the rectangle $ABCD$ is given by

$$P = 24 \cos \theta + 18 \sin \theta.$$

[3]

- (ii) Express P in the form $P = R \cos(\theta - \alpha)$ where R is positive and α is acute.

[4]

Name: _____ () Class: _____

11 (iii) Given that θ varies, state the maximum value of P and the corresponding value of θ .
[2]

(iv) Find the values of θ for which $P = 28$ cm.
[4]

Name: _____ ()

Class: _____

12 A particle starts from point O and moves in a straight line with a velocity, $v \text{ ms}^{-1}$, given by

$$v = 5e^{-t} - \frac{1}{5} \text{ where } t \text{ is the time in seconds after leaving } O. \text{ Calculate the}$$

(i) initial velocity of the particle,

[1]

(ii) value of t when the particle is instantaneously at rest,

[3]

Name: _____ () Class: _____

12 (iii) acceleration of the particle when it is instantaneously at rest,
[3]

(iv) distance travelled from $t = 0$ to $t = 5$.
[5]



Name: _____ ()

Class: _____

Sec 4/5 Preliminary Examination 2019
Additional Mathematics Paper 1
Answer Key

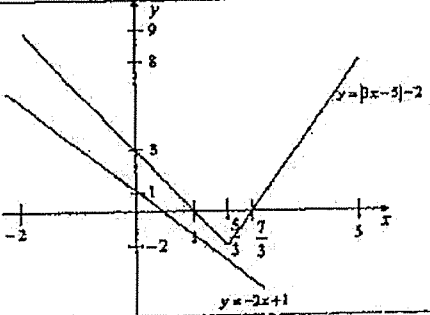
1(i)	$k > \frac{25}{12}$	1(ii)	For values of $k > \frac{25}{12}$, $3x^2 - 5x + k > 0$ $(x-2)^2 \geq 0$ for all real values of x . Therefore $\frac{(x-2)^2}{3x^2 - 5x + k} \geq 0$
2	$x = 16$	3	$-\frac{621}{200}$ or $-3\frac{21}{200}$ or -3.105 .
4(i)		4(ii)	$y = -2x + 1$
		4(iii)	0 solutions
5	20	6(ii)	$x = -23.6^\circ, -156.4^\circ, 203.6^\circ, 336.4^\circ$
7(i)	12 cm	7(ii)	$\frac{1}{4}$ cm ² /s
7(iii)	The rate will decrease. Since $\frac{dr}{dt} = \frac{3}{r}$ (as $r \uparrow$, $\frac{dr}{dt} \downarrow$)	8(i)	$2x - 3 - \frac{2}{3x+2} + \frac{1}{2x-1}$
8(ii)	$x^2 - 3x - \frac{3}{2} \ln 3x+2 + \frac{1}{2} \ln 2x-1 + c$	9	$y = \frac{3}{2}x^3 - 3x^2 + \frac{3}{2}x + 4$
10(ii)(a)	$p = 2.0$ (Accept 1.9 - 2.1) $q = 3.0$ (Accept 2.5 - 3.1)	10(ii)(b)	$x = 4.39$ (Accept 4.36 - 4.49)
11(i)	$y = x - 3$	11(ii)	Q(9, 0) S(3, 6)
11(iii)	T(-15, 24)	11(iv)	96 units ²
11(v)	18.8 units	12(iii)	$x = \frac{2}{3}$ Maximum $V = 9.93$ cm ³

~ End of Paper ~
 Sec 4 Express Prelim Examination 2019
 Additional Mathematics Paper 2
 Answer Key

1. $h = 2 + \sqrt{3}$
 2. (ii) 50
 (iii) As t becomes very large, $e^{-0.14t}$ approaches zero.

Therefore, P approaches 100.

This means that the population of Cockatoos will not exceed 100.

- 3 (i) $a = 3, b = 3, c = 1$

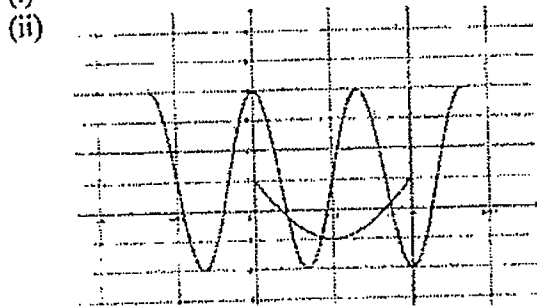

4(i) $\frac{dy}{dx} = \frac{18}{(3+x)(5x-3)}$

4(ii) For $x > \frac{3}{5}$, $5x - 3 > 0$.

Since $(3+x) > 0$ and $(5x-3) > 0$ for $x > \frac{3}{5}$,

$\Rightarrow (3+x)(5x-3) > 0$

$\therefore \frac{18}{(3+x)(5x-3)} < 0$ for $x > \frac{3}{5}$,

$\Rightarrow \frac{dy}{dx} < 0$

Thus, y is a decreasing function for $x > \frac{3}{5}$ (Shown)

5(ii) $\therefore a = -3\frac{309}{343}, b = 3\frac{276}{343}$

6(i) $\frac{3}{4}$

6(ii) $C(0, -2)$

6(iii) $D(-6, 6)$

6(iv) 50 units²

7(a) $x = 3, y = 4$

7(b) $x = 1$ or 2.46 (to 3 s.f.)

7(c) $c = p - 3q$

8(ii) $f(x) = (3x-2)(2x^2+9)$

8(iii) $\frac{2}{3x-2} - \frac{4x+5}{2x^2+9}$

9(i) $PQ = \frac{5}{3}(15-x)$

9(ii) -0.0918 (to 3 s.f.) or $-\frac{9}{98}$ cm/s

9(iii)

10(i) $2 + \frac{2}{2x-1}$

10(ii) $\frac{4x}{2x-1} + 2 \ln(2x-1)$

10(iii) $x \ln(2x-1) - x - \frac{1}{2} \ln(2x-1) + c$

11(ii) $P = 30 \cos(\theta - 36.9)^\circ$ (to 1 d.p.)

11(iii) Max. $P = 30$ when $\theta = 36.9^\circ$

11(iv) $\theta = 15.8^\circ, 57.9^\circ$

12(i) $4\frac{4}{5}$ m/s

12(ii) $\ln 25$ or 3.22 (to 3 s.f.)

12(iii) -0.2 m/s²

12(iv) 4.35 m (to 3 s.f.)