



FUCHUN SECONDARY SCHOOL
 Secondary 4 Express / 5 Normal Academic
 Mid-Year Examination 2021

CANDIDATE
 NAME

CENTRE
 NUMBER

S	2	2	4	6
---	---	---	---	---

INDEX
 NUMBER

--	--	--	--

CLASS

MATHEMATICS

Paper 1

4048/01

6 May 2021

2 hours

Candidates answer on the Question Paper

READ THESE INSTRUCTIONS FIRST

Write your Centre number, index number and name on all the work you hand in.

Write in dark blue or black pen.

You may use an HB pencil for any diagrams or graphs.

Do not use staples, paper clips, highlighters, glue or correction fluid.

Answer **all** questions.

If working is needed for any question it must be shown with the answer.

Omission of essential working will result in loss of marks.

The use of an approved scientific calculator is expected, where appropriate.

If the degree of accuracy is not specified in the question, and if the answer is not exact, give the answer to three significant figures. Give answers in degrees to one decimal place.

For π , use either your calculator value or 3.142, unless the question requires the answer in terms of π .

The number of marks is given in brackets [] at the end of each question or part question.

The total number of marks for this paper is 80.

For Examiner's Use

Name of Setter: Mr Johni Masli

This document consists of 17 printed pages and 1 blank page.

[Turn over

Mathematical Formulae

<i>Compound interest</i>	Total amount = $P\left(1 + \frac{r}{100}\right)^n$
<i>Mensuration</i>	Curved Surface area of a cone = πrl
	Surface area of a sphere = $4\pi r^2$
	Volume of a cone = $\frac{1}{3}\pi r^2 h$
	Volume of a sphere = $\frac{4}{3}\pi r^3$
	Area of triangle $ABC = \frac{1}{2}ab \sin C$
	Arc length = $r\theta$, where θ is in radians
	Sector area = $\frac{1}{2}r^2\theta$, where θ is in radians
<i>Trigonometry</i>	$\frac{a}{\sin A} = \frac{b}{\sin B} = \frac{c}{\sin C}$
	$a^2 = b^2 + c^2 - 2bc \cos A$
<i>Statistics</i>	Mean = $\frac{\sum fx}{\sum f}$
	Standard deviation = $\sqrt{\frac{\sum fx^2}{\sum f} - \left(\frac{\sum fx}{\sum f}\right)^2}$

1. Write the following numbers in order of size, starting with the smallest.

$$33\% \quad \frac{1}{3} \quad \left(\frac{1}{3}\right)^2 \quad -0.3$$

Answer , , , [2]

2. The line $4y - 3x = 21$ crosses the x -axis at A .

Find

- (a) the gradient of the line,

Answer [1]

- (b) the coordinates of point A .

Answer A (..... ,) [1]

3. A school has 360 students.

The ratio of the number of boys to the number of girls is 3 : 5.

On one day, 15 boys and 15 girls were absent.

Find the ratio of the number of boys to the number of girls on that day.

Give your answer in its simplest form.

Answer : [2]

[Turn over

4. Sally invested \$20 000 in a savings account paying simple interest at r % per year.
After 3.5 years, there was \$23 150 in her account.
Calculate the value of r .

Answer $r =$ [2]

5. Complete the sentence below.

If y cm² is the total surface area of a cube with side of x cm,

y is proportional to , where $k =$ [2]

6. A conical paper cup, as shown in the diagram, is filled up to $\frac{1}{2}$ of its maximum height.

Kumar claimed that the paper cup is filled to 50% of its capacity.

Explain whether his statement is true.

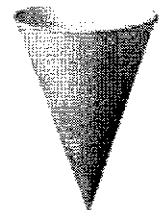

.....

.....

.....

.....

.....

.....

..... [2]

7. Sarah knows that one angle of an isosceles triangle is 50° .

She says that one of the other angles **must** be $\frac{180^\circ - 50^\circ}{2} = 65^\circ$.

Explain why Sarah is wrong.

.....
 [2]

8. It is given that $x^2y = 5 + 4y$.

(a) Find y when $x = -3$.

Answer $y =$ [1]

(b) Rearrange the formula to make y the subject.

Answer [2]

9. 100 grams of peanuts contain 25.8 grams of protein.

Calculate the mass of protein in 248.9 kilograms of peanuts, in grams.

Leave your answer in standard form, correct to 3 significant figures.

Answer grams [3]

[Turn over

10. (a) Expand and simplify $2-3(2-3x)$.

Answer [1]

- (b) Factorise $6ax+9bx-4a-6b$.

Answer [2]

11. The total surface area of a cylindrical solid with radius r and height h is twice the total surface area of a sphere with radius r .

Find h in terms of r .

Answer [3]

12. A map is drawn to a scale of 1 : 50 000.

- (a) Two towns P and Q are 5 km apart.

Calculate, in metres, the distance PQ on the map.

Answer m [1]

- (b) A lake has an actual area of 10 km^2 .

Find the area, in square centimetres, of the lake on the map.

Answer cm^2 [2]

13. Sketch the graph of $y = -(x-8)(x+2)$ on the axes below.

Indicate clearly the coordinates of the maximum point and the values where the graph crosses the axes on the curve.

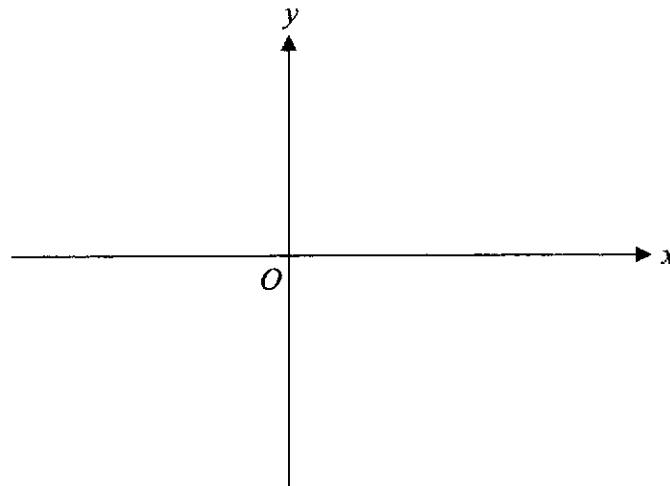

[3]

14. (a) Simplify $\left(\frac{625}{a^8}\right)^{-\frac{1}{4}}$, leaving your answer in positive index notation.

Answer [2]

- (b) Given that $9^n \times \sqrt{3} = 1$, find the value of n .

Answer $n =$ [2]

[Turn over

15. (a) Express 720 as the product of its prime factors.

Answer [1]

- (b) Given that $720k = m^3$, where k and m are positive integers and m is as small as possible, find the value of k and of m .

Answer $k =$
 $m =$ [1]

- (c) The lowest common multiple of two numbers is 720.
 The highest common factor of these two numbers is 24.
 Both numbers are smaller than 150.
 Find the two numbers.

Answer , [2]

16. (a) Use the set notation to describe the shaded region.

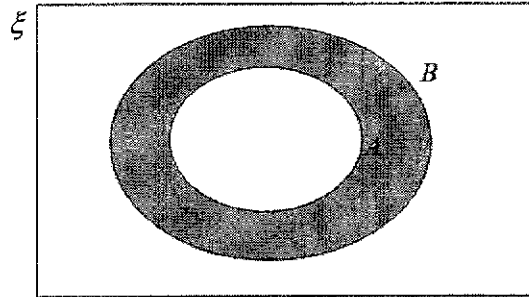

Answer [1]

- (b) $\xi = \{ \text{integers } x: 1 \leq x \leq 6 \}$

$A = \{ \text{prime numbers} \}$

$B = \{ \text{multiples of 3} \}$

- (i) List the elements of $A \cap B'$.

Answer [1]

- (ii) On the Venn diagram below, shade the region which represents $A \cap B'$.

Answer

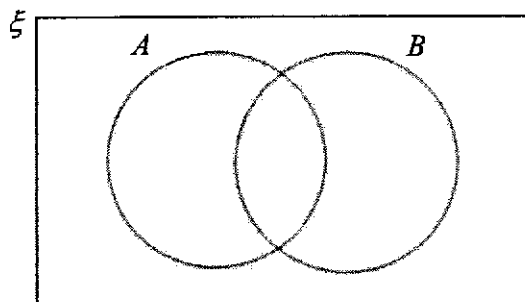

[1]

- (iii) Underline the correct statement from the list below.

$5 \subset A$

$\{ \} \not\subset B$

$(A' \cap B) \subset \xi$

[1]

[Turn over

17. The diagram shows the path of a plane from airport A to airport B .
 C is due south of B , A is due west of C .

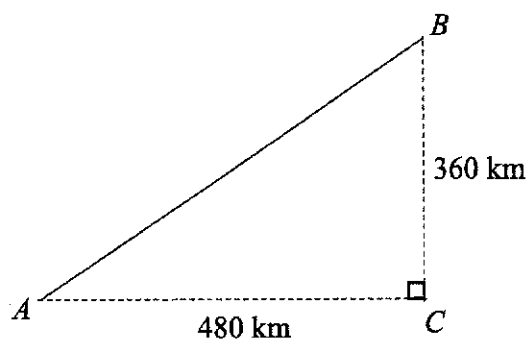

The plane flies at an average speed of 444 km/h.

It leaves A and flies **directly** to B .

Calculate the time taken for the plane to reach B .

Give your answer in hour(s) and minute(s), to the nearest minute.

Answer hour(s) minute(s) [4]

18. The zoo is setting up a new Panda Park on a plot of land $STUV$.

There is a waterfall at W and a bamboo forest at B , as shown in the diagram below.

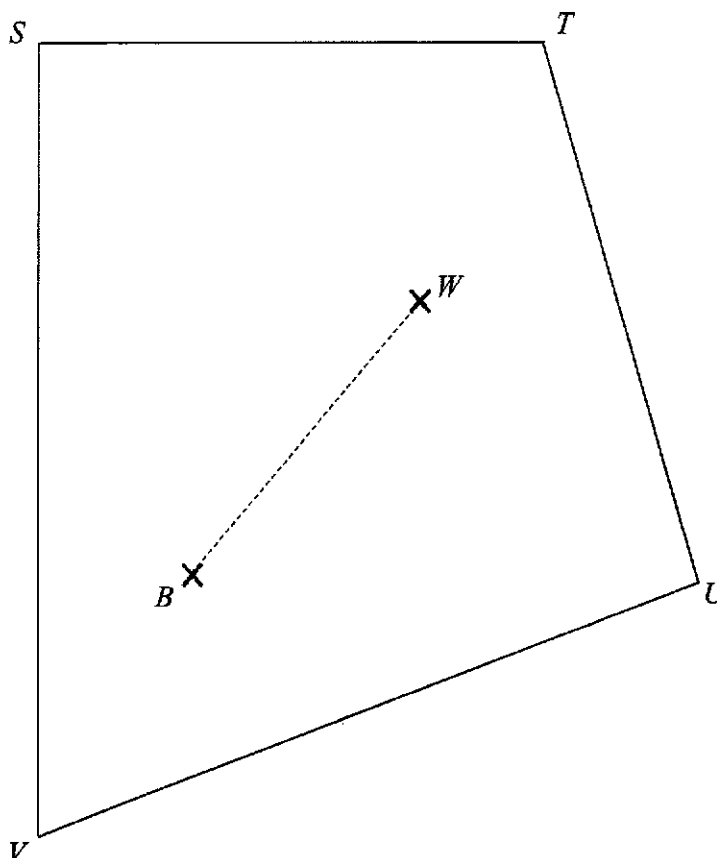

- (a) Construct the perpendicular bisector of BW . [1]

The panda enclosure is to be built in the park such that it is equidistant from the waterfall (W) and the bamboo forest (B).

It must also be nearer to edge ST than to UT .

- (b) By showing the necessary construction line(s) clearly, label one possible location of the panda enclosure with a P . [3]

[Turn over

19. Die A has the numbers 1, 2, 3 and 4 engraved on it while die B has the numbers 2, 3 and 5 engraved on it. They are rolled one after another.

- (a) Complete the possibility diagram.

		Die B		
		2	3	5
Die A	1			(1,5)
	2	(2,2)		
	3	(3,2)	(3,3)	(3,5)
	4		(4,3)	(4,5)

[1]

- (b) Giving your answer as a fraction in its simplest form, find the probability that

- (i) both dice are even numbers,

Answer [1]

- (ii) product of the two numbers is less than 10.

Answer [1]

- (c) Using the experiment above, give one example of an event E, such that $P(E)$ is $\frac{1}{4}$.

.....
 [1]

20. Alex had 4 tests in a semester and the results were A , B , C and D respectively.

He calculated his mean score and standard deviation using a calculator and obtained 67.5 for mean and 9 for standard deviation.

(a) Based on the information, find the value of

(i) $A + B + C + D$,

Answer [1]

(ii) $A^2 + B^2 + C^2 + D^2$.

Answer [2]

(b) While checking, Alex realised that he had entered one of the scores wrongly.

The score should be 86 instead of 68.

Calculate the correct mean.

Answer [1]

[Turn over

21. The table below shows the number of cups of four brands of ice cream sold at 2 dessert shops on a particular day.

	Shop 1	Shop 2
Brand <i>A</i>	5	3
Brand <i>B</i>	11	7
Brand <i>C</i>	8	9
Brand <i>D</i>	5	12

- (a) Write down a 4×2 matrix \mathbf{Q} that represents the data in the table above.

Answer $\mathbf{Q} =$ [1]

A cup of ice cream costs \$5 for Brand *A*, \$10 for Brand *B*, \$8 for Brand *C* and \$ x for Brand *D*.

The information can be represented by the matrix $\mathbf{P} = \begin{pmatrix} 5 & 10 & 8 & x \end{pmatrix}$.

- (b) Find, in terms of x , matrix $\mathbf{R} = \mathbf{PQ}$.

Answer $\mathbf{R} =$ [1]

- (c) Explain what each of the elements in \mathbf{R} represent.

.....
 [1]

- (d) Both shops collected the same amount of money that day.

Calculate the value of x .

Answer $x =$

22. In the diagram, the points A, B, C, D and E lie on a circle, centre O .

AD is a diameter of the circle, M is the point on BE such that $EM = BM$ and $\angle BCD = 121^\circ$.

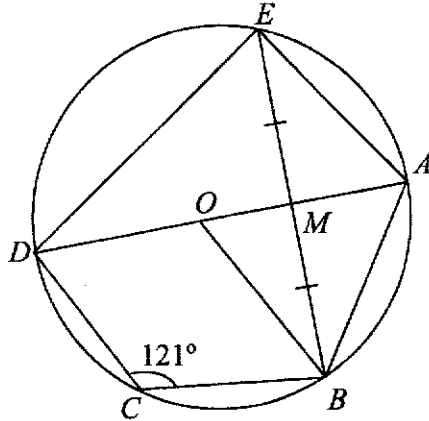

(a) Find

(i) angle BAD ,

Answer [1]

(ii) angle AEB .

Answer [2]

(b) Explain whether line AE is parallel to line BO .

.....

.....

.....

.....

.....

..... [2]

[Turn over

23. The diagram shows a regular octagon $ABCDEFGH$.

AB and DC are extended to meet at P .

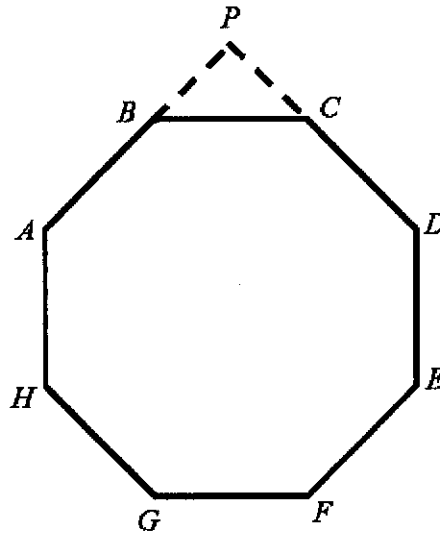

(a) Find angle CDE .

Answer [1]

(b) Show that angle BPC is a right angle.

Answer

[2]

(c) Given that $CG = 8$ cm, find the area of this octagon.

Answer cm^2 [2]

24. The lengths of the sides of an equilateral triangle are $(3x + y - 3)$ cm, $(2x + 3y)$ cm and $(x + 4y + 5)$ cm.

- (a) Write down and simplify two simultaneous equations, in terms of x and y , to represent this information.

Answer 1st equation [1]
 2nd equation [1]

- (b) Solve the simultaneous equations to find the perimeter of the triangle.

Answer Perimeter = cm [4]

BLANK PAGE



FUCHUN SECONDARY SCHOOL
 Secondary 4 Express / 5 Normal Academic
 Mid-Year Examination 2021

CANDIDATE
 NAME

CENTRE
 NUMBER

S	2	2	4	6
---	---	---	---	---

INDEX
 NUMBER

--	--	--	--

CLASS

MATHEMATICS

Paper 2

4048/02

10 May 2021

2 hours 30 minutes

Candidates answer on the Question Paper

READ THESE INSTRUCTIONS FIRST

Write your Centre number, index number and name on all the work you hand in.

Write in dark blue or black pen.

You may use an HB pencil for any diagrams or graphs.

Do not use staples, paper clips, highlighters, glue or correction fluid.

Answer **all** questions.

If working is needed for any question it must be shown with the answer.

Omission of essential working will result in loss of marks.

The use of an approved scientific calculator is expected, where appropriate.

If the degree of accuracy is not specified in the question, and if the answer is not exact, give the answer to three significant figures. Give answers in degrees to one decimal place.

For π , use either your calculator value or 3.142, unless the question requires the answer in terms of π .

The number of marks is given in brackets [] at the end of each question or part question.

The total number of marks for this paper is 100.

For Examiner's Use

Name of Setter: Mr Johni Masli

This document consists of 21 printed pages and 1 blank page.

[Turn over

Mathematical Formulae

<i>Compound interest</i>	Total amount = $P\left(1 + \frac{r}{100}\right)^n$
<i>Mensuration</i>	Curved Surface area of a cone = πrl
	Surface area of a sphere = $4\pi r^2$
	Volume of a cone = $\frac{1}{3}\pi r^2 h$
	Volume of a sphere = $\frac{4}{3}\pi r^3$
	Area of triangle $ABC = \frac{1}{2}ab \sin C$
	Arc length = $r\theta$, where θ is in radians
	Sector area = $\frac{1}{2}r^2\theta$, where θ is in radians
<i>Trigonometry</i>	$\frac{a}{\sin A} = \frac{b}{\sin B} = \frac{c}{\sin C}$
	$a^2 = b^2 + c^2 - 2bc \cos A$
<i>Statistics</i>	Mean = $\frac{\sum fx}{\sum f}$
	Standard deviation = $\sqrt{\frac{\sum fx^2}{\sum f} - \left(\frac{\sum fx}{\sum f}\right)^2}$

1. (a) The first four terms of a sequence are 2, 5, 8 and 11.

(i) Write down the 6th term of the sequence.

Answer [1]

(ii) Write down an expression for the n th of this sequence.

Answer [1]

(iii) Explain whether 2021 is a term of this sequence.

.....
 [2]

(b) The first four terms in a different sequence of numbers are given below.

$$T_1 = 2^2 - 1 = 3$$

$$T_2 = 5^2 - 1 = 24$$

$$T_3 = 8^2 - 1 = 63$$

$$T_4 = 11^2 - 1 = 120$$

(i) Find T_5 .

Answer [1]

(ii) Find and simplify an expression, in terms of n , for T_n .

Answer [2]

(iii) Hence explain why the terms of the sequence are all multiples of 3.

.....
 [1]

[Turn over

2. The diagram shows the speed-time graph for a bus journey between two places.

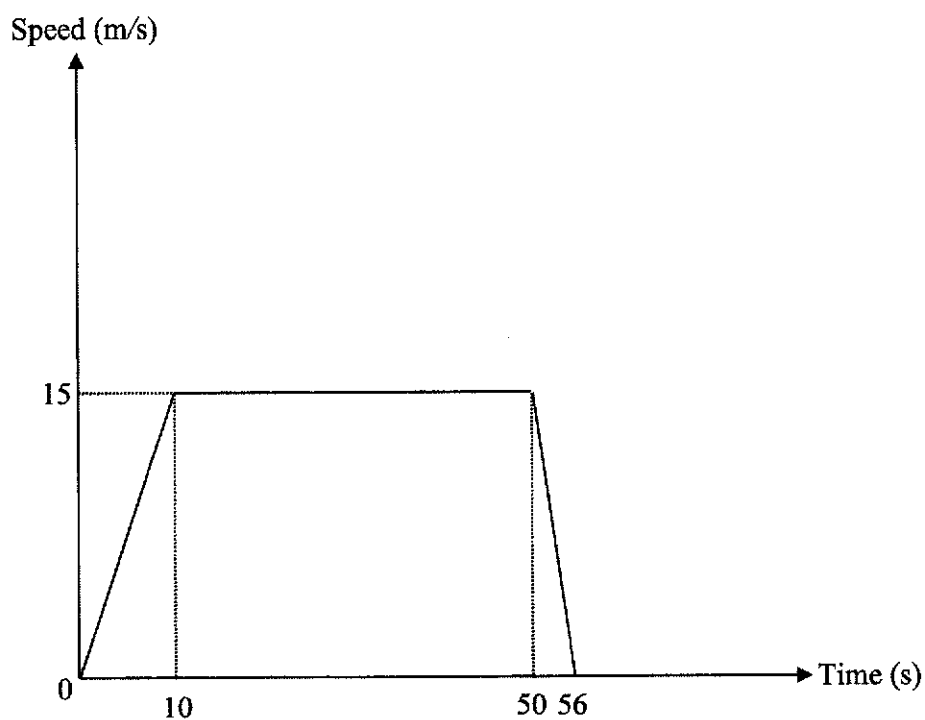

- (a) Find the deceleration after 52 seconds.

Answer m/s^2 [1]

- (b) Describe the motion of the bus between $t = 10$ seconds and $t = 50$ seconds.

.....
 [1]

5

- (c) Find the distance travelled by the bus in the first 50 seconds.

Answer m [2]

A car started its journey from rest 10 seconds later after the bus.

It took the same route as the bus.

It accelerated uniformly until it met the bus at $t = 50$ seconds.

- (d) Calculate the speed of the car at $t = 50$ seconds.

Answer m/s [2]

[Turn over

3. (a) Solve the inequality $-2 < 1 - 2x \leq 5$.

Answer [2]

- (b) Alan claimed that 5^{22} is larger than 3^{33} .

Explain whether his claim is true without using a calculator.

.....
.....
.....
..... [2]

- (c) Simplify $\frac{3x^2 + x - 2}{27x^2 - 12}$.

Answer [3]

(d) Express as a single fraction in its simplest form $\frac{5x}{(3x-2)^2} + \frac{2}{2-3x}$.

Answer [3]

(e) (i) Express $5-9x+x^2$ in the form of $q+(x-p)^2$.

Answer [2]

(ii) Hence find the minimum value of $5-9x+x^2$.

Answer [1]

[Turn over

4 On Saturday, the exchange rate between Euros (€) and Singapore Dollars (S\$) was $\text{€}1 = \text{S\$ } x$.

(a) Mr Lee changed S\$480 into Euros.

Write down an expression, in terms of x , for the amount of Euros that he received on Saturday.

Answer € [1]

On Sunday, the Euros grew stronger and the exchange rate was $\text{€}1 = \text{S\$ } (x - 0.1)$.

(b) Mr Lee changed another S\$300 into Singapore Dollars.

Write down an expression, in terms of x , for the amount of Euros that he received on Sunday.

Answer € [1]

(c) Mr Lee realised that he received €100 more on Saturday than on Sunday.

Form an equation in x and show that it reduces to $50x^2 - 95x + 24 = 0$.

Answer

[3]

(d) Solve the equation $50x^2 - 95x + 24 = 0$.

Answer $x = \dots\dots\dots$, $x = \dots\dots\dots$ [4]

(e) Mrs Lim changed €1000 into Singapore Dollars on Sunday.

Given that $x > 1$, calculate the amount of Singapore Dollars that she received.

Answer S\$ $\dots\dots\dots$ [1]

[Turn over

5

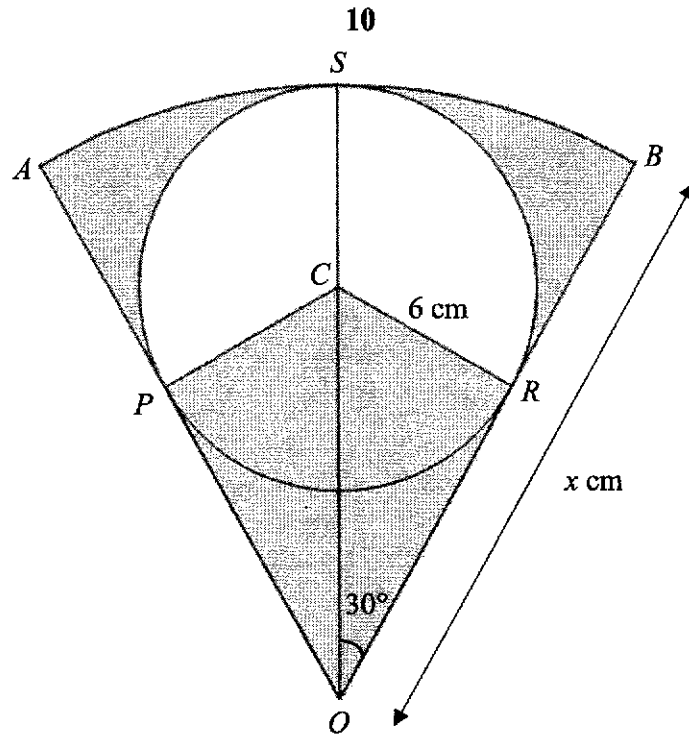

The diagram shows a sector OAB of a circle with centre O and radius x cm.

A circle with centre C and radius 6 cm lies within the sector and touches the sector OAB at P , R and S .

It is given that angle ROC is 30° .

(a) Show that triangle CRO is congruent to triangle CPO .

.....

.....

.....

.....

.....

[3]

(b) Show that $x = 18$.

Answer

[2]

- (c) Calculate the perimeter of the **unshaded** region, *CPSRC*.

Write your answer in terms of $a + b\pi$.

Answer cm [3]

- (d) Calculate the total area of the shaded regions.

Answer cm² [3]

[Turn over

6

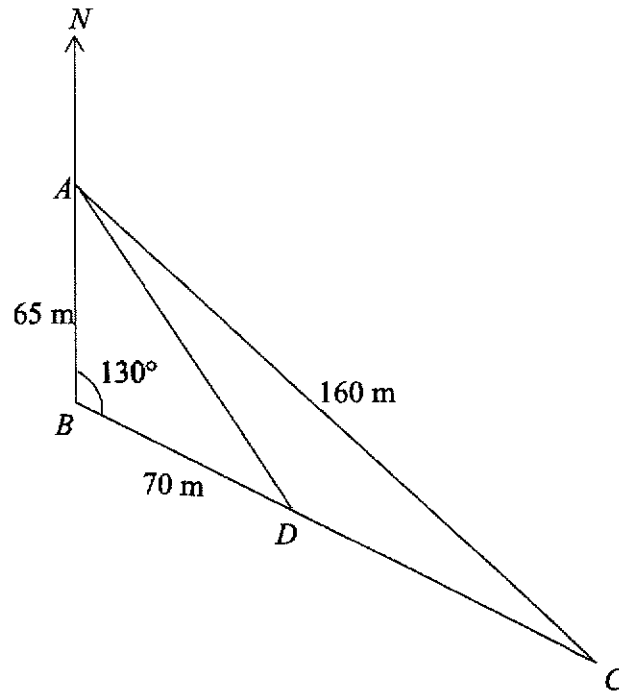

In the diagram, ABC is a horizontal triangular plot of land and D lies on BC .

$AB = 65$ m, $BD = 70$ m, $AC = 160$ m and angle $ABD = 130^\circ$.

(a) Find the distance AD .

Answer m [3]

(b) Show that angle $BAC = 31.87^\circ$.

Answer

[3]

13

- (c) Find the bearing of A from C .

Answer [2]

- (d) A bird is hovering vertically above B .
The angle of elevation of the bird from A is 20° .
Find the angle of elevation of the bird when viewed from D .

Answer [3]

[Turn over

- 7 (a) 200 students from school *A* recorded the time, t minutes, for their journey from home to school.

The results are shown in the cumulative frequency graph.

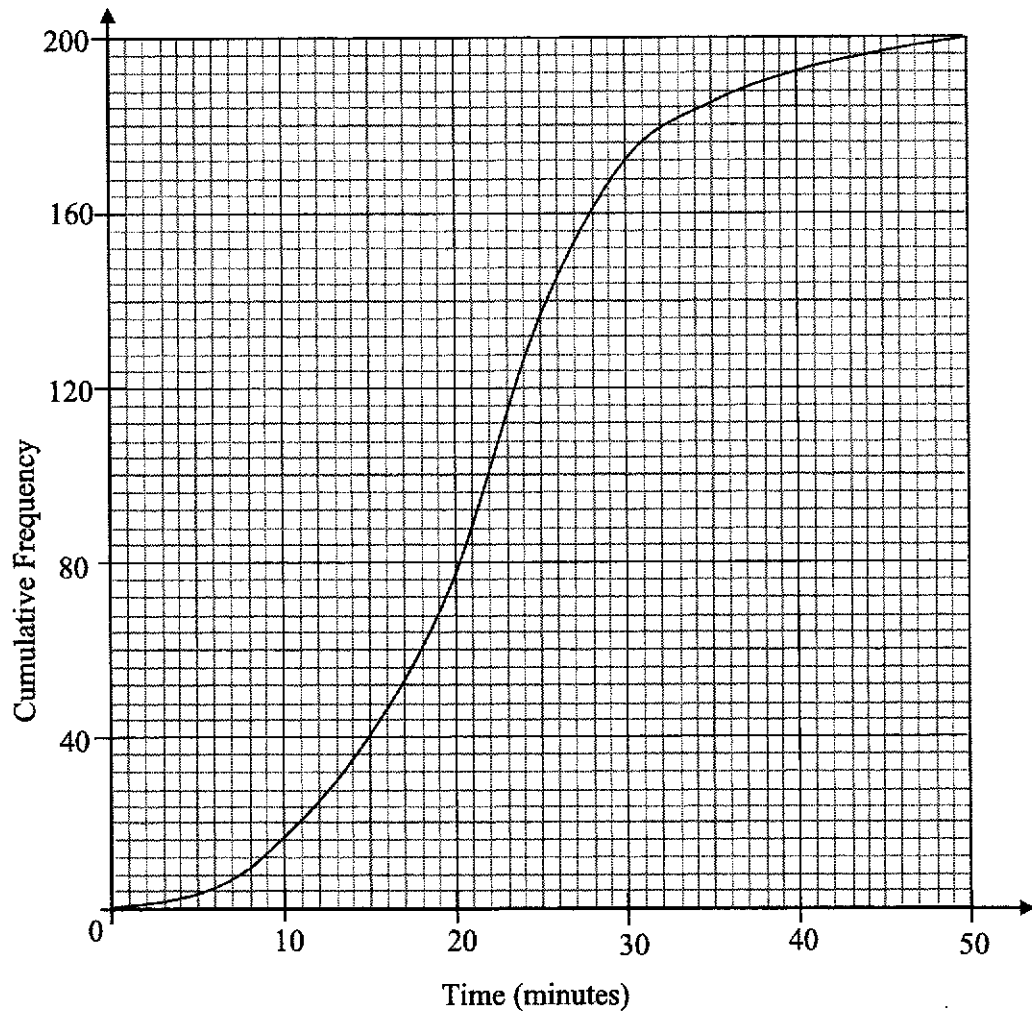

Using the graph to find the

- (i) number of students who took between 15 and 40 minutes,

Answer [2]

- (ii) interquartile range.

Answer minutes [2]

200 students from school *B* also recorded their journey time from home to school and the information could be found in the table.

Lower Quartile	Upper Quartile
15 minutes	30 minutes

- (iii) Susi mentioned that there are more students in school *A* than in school *B* who took more than 30 minutes to reach school.

Explain whether her statement is correct.

.....

.....

.....

.....

.....

[2]

- (b) A bag contains 5 red balls, 4 blue balls and 3 green balls.

Two balls are taken out at random without replacement.

Find, in its simplest form, the probability that

- (i) one red ball and one green ball are selected,

Answer [2]

- (ii) both balls are of the same colours.

Answer [2]

A third ball is taken out.

- (iii) Find the probability that none of the three balls taken out is red.

Answer [1]

[Turn over

- 8 The variables x and y are connected by the equation $y = \frac{8}{x^2} + 2x - 7$.

Some corresponding values of x and y are given in the following table.

x	1	1.5	2	3	4	5	6
y	3	-0.44	-1	-0.11	1.5	3.32	p

- (a) Find the value of p .

Answer [1]

- (b) On the grid opposite, draw the graph of $y = \frac{8}{x^2} + 2x - 7$ for $1 \leq x \leq 6$. [3]

- (c) Use the graph to write down the range of values x where $\frac{8}{x^2} + 2x < 8$.

Answer [2]

- (d) By drawing a tangent, find the gradient of the curve at $x = 1.5$.

Answer [2]

- (e) (i) On the same axes, draw a line that passes through $(2, 0)$ and has gradient of -1 . [2]

- (ii) Write down the x -coordinates of the points where this line intersects the curve.

Answer $x = \dots\dots\dots$, $x = \dots\dots\dots$ [1]

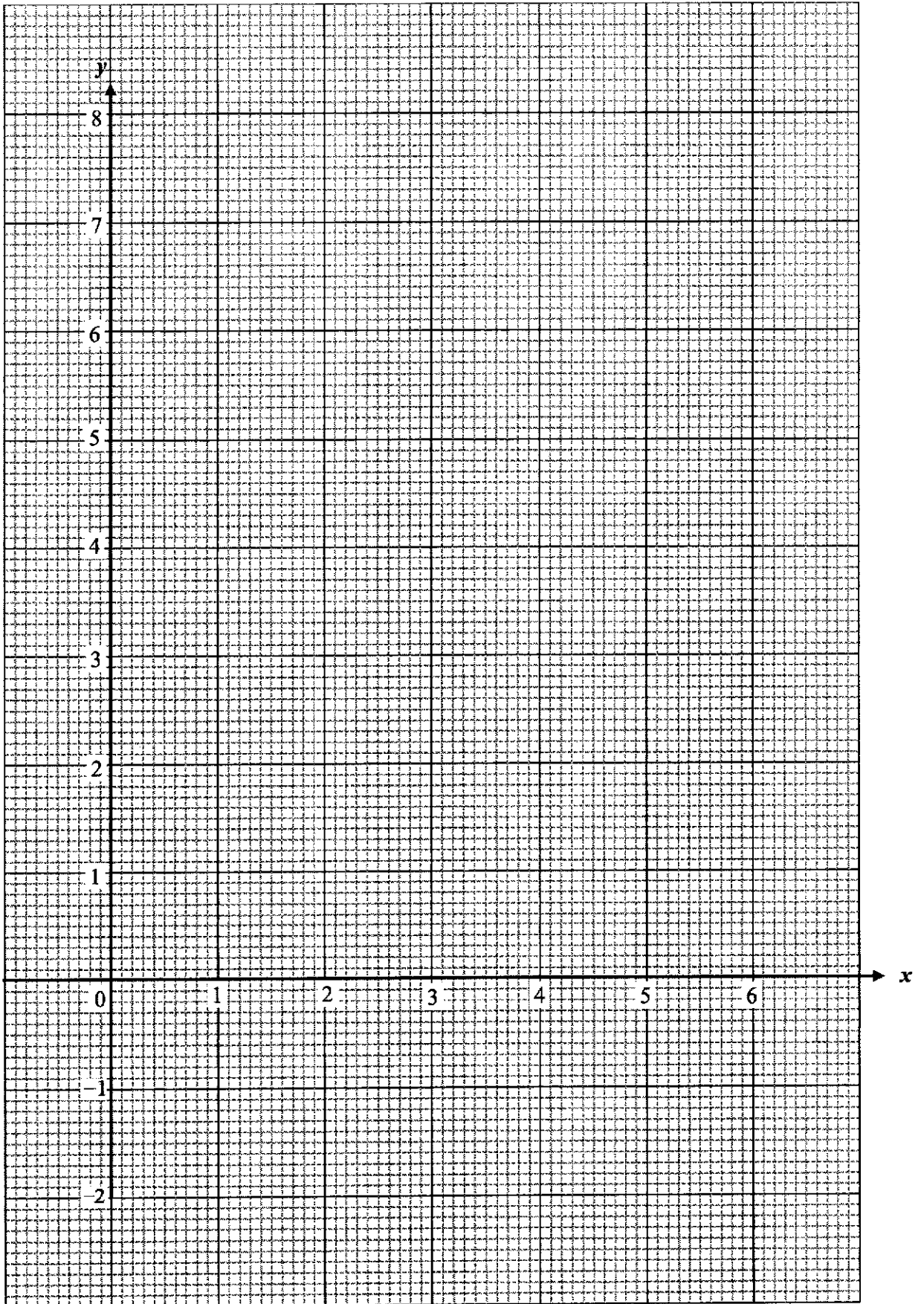

[Turn over

- 9 A beverage factory produces soft drink in a bottle, as shown in figure 1.

The bottle can be modelled as a frustum attached to the top of a cylinder as shown in figure 2.

The measurements are given in the table.

Diameter (D_1) of the base of the bottle = 84 mm.
Diameter (D_2) of bottle opening = 36 mm
Height (H_1) = 80 mm
Height (H_2) = 120 mm



Figure 1

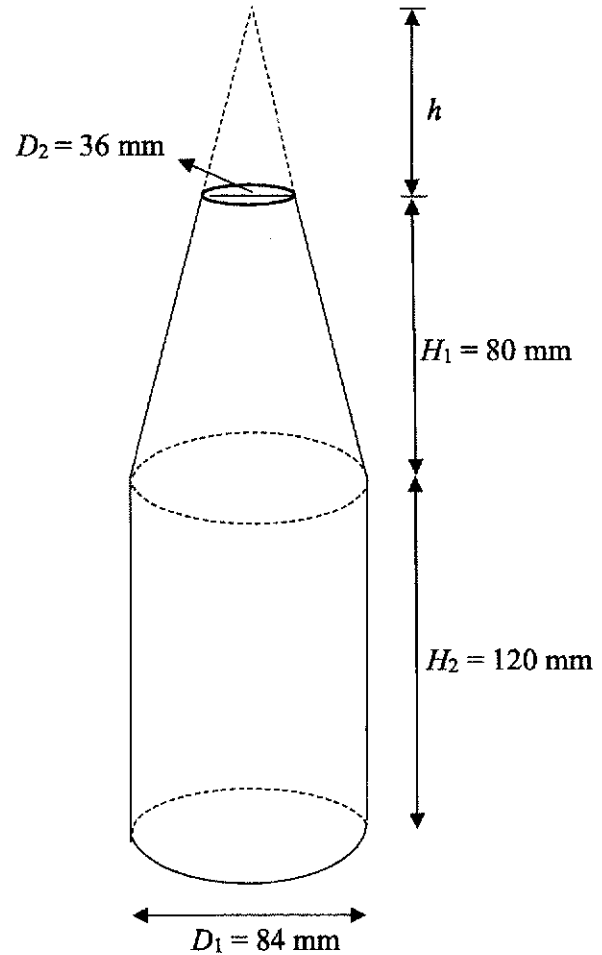

Figure 2

- (a) Using similarity, show that $h = 60$ mm.

Answer

[2]

- (b) Calculate the volume, in cubic centimeters, of the bottle in Figure 2.

Answer cm^3 [5]

- (c) Another bottle is to be made with a volume that is **half** the volume of the bottle in Figure 2.
Given that the two bottles are geometrically similar, find the height of the smaller bottle.

Answer mm [2]

[Turn over

- 10 The table below shows the flag-down rate and charges for SBC taxi.

Metered Fare	
Flag down rate (inclusive of first 1 km or less)	\$3.50
Distance rate (beyond 1 km)	
Every 400 m up to 10 km	\$0.22
Every 300 m after 10 km	\$0.25
Traffic waiting time rate	
Every 45 seconds of waiting or less	\$0.22

Time-based Additional Surcharges	
Peak period surcharge (6 am to 9.29 am and 6 pm to 11.59 pm)	30% of metered fare
Late night surcharge (12.00 am to 5.59 am)	50% of metered fare

- (a) Bryan hailed and got into a taxi during the non-peak period to travel to his workplace.

The total distance covered by the taxi is 11 km and the traffic waiting time is about 90 seconds.

Calculate how much Bryan paid for his taxi fare.

Answer \$ [3]

Below is some additional information about the payment method.

Payment by Easy Link Card	\$0.30 charge on top of metered fare
Payment by Go Card	5% discount of the total fare

(b) Lisa hailed a taxi to return to her house.

She boarded the taxi at 7 pm and reached her house at 7.30 pm.

During the journey, the traffic waiting time is about 5 minutes.

She used Go Card and paid \$27.84 for the fare.

Suggest what is a likely average speed of the taxi during this journey, in km/h.

Answer km/h [7]

BLANK PAGE

Paper 1

1. $-0.3, \left(\frac{1}{3}\right)^2, 33\%, \frac{1}{3}$ [B2: all correct, B1 for three numbers in the correct sequence]

2. (a) $\frac{3}{4}$ [B1] (b) $A(-7, 0)$ [B1]

3. Number of boys = 135, number of girls = 225 [B1]
New ratio on that day = 4 : 7 [B1]

4. Amount of interest = \$3150

$$3150 = \frac{20000 \times r \times 3.5}{100} \quad [\text{M1: correct amount of interest and attempt to use the formula}]$$

$$r = 4.5 \text{ [A1]}$$

OR interest per year = \$900 [M1: correct amount of interest/year]

$$r \% = \frac{900}{20000} \times 100\% = 4.5\%$$

$$r = 4.5 \text{ [A1]}$$

5. y is directly proportional to x^2 with $k = 6$. [B2: all correct, B1: 2 correct answers]

6. $\frac{V_1}{V_2} = \left(\frac{1}{2}\right)^3$ [B1] or attempt to say that the volume of upper half is not equal to volume of

lower half. However, correct terminology must be used.

$$\frac{V_1}{V_2} = 0.125$$

His statement is not **true** as it is only filled to **12.5%** of its capacity. [B1]

7. Sarah is **wrong** as there is other possible angle. [B1]

OR 50° could be one of the base angles.

The other angle could also be $180^\circ - 50^\circ - 50^\circ = 80^\circ$. [B1: s.o.i.]

8. (a) 1 [B1]

(b) $x^2y - 4y = 5$ [M1]

$$y(x^2 - 4) = 5$$

$$y = \frac{5}{x^2 - 4} \text{ [A1]}$$

9. 100 grams peanuts rep. 25.8 grams protein
 248.9 × 1000 grams peanuts [B1: correct conversion]

$$248900 \text{ grams peanuts rep. } \frac{248900}{100} \times 25.8 \text{ [M1]}$$

$$= 6.42 \times 10^4 \text{ grams of protein [A1]}$$

10. (a) $9x - 4$ [B1]

(b) $6ax + 9bx - 4a - 6b$

$$= 3x(2a + 3b) - 2(2a + 3b) \text{ [M1]}$$

$$= (3x - 2)(2a + 3b) \text{ [A1] No mark is awarded if the method is wrong.}$$

For a slip and correct answer, award B1 only

11. Total surface area of cylinder = $2\pi r^2 + 2\pi rh$ [B1]

$$\text{Surface area of sphere} = 4\pi r^2$$

$$2\pi r^2 + 2\pi rh = 2(4\pi r^2) \text{ [M1 } \checkmark \text{: total SA of cylinder} = 2(\text{surface area of sphere})]$$

$$h = 3r \text{ [A1]}$$

12. (a) 0.1m [B1]

(b) 1cm rep. 0.5km

$$1\text{cm}^2 \text{ rep. } 0.25 \text{ km}^2 \text{ [M1: must square and indicate the correct unit]}$$

$$\text{Area on map} = 40 \text{ cm}^2 \text{ [A1]}$$

- 13.

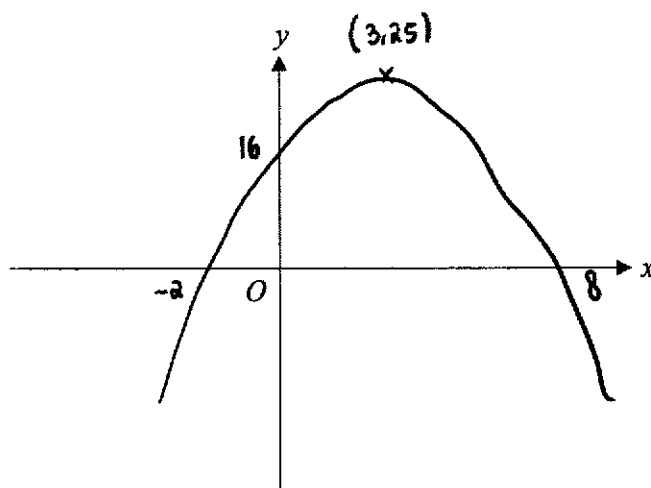

B1: correct x-intercepts and y-intercept

B1: correct turning point – coordinates of the point must be written

B1: correct shape (concave downward, symmetrical, cuts x- and y-axis)

$$14. (a) \left(\frac{625}{a^8}\right)^{-\frac{1}{4}}$$

$$= \left(\frac{a^8}{625}\right)^{\frac{1}{4}} \quad [\text{M1}]$$

$$= \frac{a^2}{5} \quad [\text{A1}]$$

$$\text{OR} \quad \left(\frac{625^{-\frac{1}{4}}}{a^{-2}}\right)$$

$$(b) 9^n \times \sqrt{3} = 1$$

$$9^n = \frac{1}{\sqrt{3}}$$

$$3^{2n} = \frac{1}{3^{0.5}} \quad [\text{M1}]$$

$$3^{2n} = 3^{-0.5}$$

$$n = -0.25 \quad [\text{A1}]$$

$$\text{OR} \quad 9^n \times \sqrt{3} = 1$$

$$3^{2n} \times 3^{0.5} = 3^0 \quad [\text{M1: at least 2 correct}]$$

$$2n + 0.5 = 0$$

$$n = -0.25 \quad [\text{A1}]$$

For guess and check, only B1 is awarded.

$$15. (a) 720 = 2^4 \times 3^2 \times 5 \quad [\text{B1}]$$

$$(b) k = 300 \text{ and } m = 60 \quad [\text{B1}]$$

$$(c) 720 = 2^4 \times 3^2 \times 5$$

$$24 = 2^3 \times 3$$

$$1^{\text{st}} \text{ number} = 2^3 \times 3 \times 5 = 120$$

$$2^{\text{nd}} \text{ number} = 2^4 \times 3^2 = 144$$

[B1: finding prime factorisation of 24 and one correct number]

[B2: both correct numbers]

$$16. (a) B \cap A' \quad [\text{B1}]$$

$$(b) (i) 2 \text{ and } 5 \quad [\text{B1}]$$

(ii) Shade the correct region [B1]

(iii) $(A' \cap B) \subset \xi$ [B1]

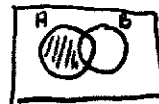

$$17. AB = 600 \text{ km} \quad [\text{B1}]$$

$$\text{time} = \frac{600}{444} \text{ hour} \quad [\text{M1: distance/speed}]$$

$$\text{time} = 1.351 \text{ hour} \quad [\text{A1}\checkmark]$$

1 hour and 21 minutes [A1\checkmark if it doesn't change level of difficulty]

18. (a) line is drawn correctly [B1]
 (b) Attempt to draw any angle bisector [B1]
 Angle bisector of UTS drawn correctly [B1]
 Correct point plotted and labelled [B1]

19. (a) (1,2), (1,3), (2,3), (2,5) and (4,2) [B1]

(b) (i) $\frac{1}{6}$ [B1] (ii) $\frac{2}{3}$ [B1]

(if both answers correct but not simplified, awards B1)

- (c) Any logical answer, where $n(E) = 3$.

For example, probability that the first die shows 1 [B1]

20. (a) (i) 270 [B1]

(ii) $9 = \sqrt{\frac{\text{sum of } x^2}{4} - 67.5^2}$ [M1]

Sum of $x^2 = 18549$ [A1]

- (b) (72 [B1])

21. (a) $\begin{pmatrix} 5 & 3 \\ 11 & 7 \\ 8 & 9 \\ 5 & 12 \end{pmatrix}$ [B1] (b) $(199 + 5x \quad 157 + 12x)$ [B1]

(c) **Amount of money** collected, **in dollars**, from selling four brands of ice-cream in **shop A and B** respectively. [B1] or in each shop respectively. **Do not accept** in both shops respectively.

- (d) \$6 [B1]

22. (a) (i) 59° [B1]

(ii) $\angle BED = 59^\circ$ [B1]

$\angle AEB = 90^\circ - 59^\circ = 31^\circ$ [B1]

OR

$\angle AOB = 180^\circ - 59^\circ - 59^\circ = 62^\circ$ [B1]

$\angle AOB = \frac{1}{2} \times 62^\circ = 31^\circ$ [B1]

For students who assume $\angle AEM = \angle ABM$, 1 mark is awarded for correct answer

(iii) $\angle MBO = 180^\circ - 90^\circ - 62^\circ = 28^\circ$ [B1]

Since $\angle MBO \neq \angle AEB$, AE is **NOT** parallel to line BO [B1]

0 mark if angle not found.

23. (a) $\angle CDE = 135^\circ$ [B1]

(b) $\angle BCP = 45^\circ$ [B1: must write down what angle is found]

Therefore, $\angle BPC = 180^\circ - 45^\circ - 45^\circ = 90^\circ$ [B1]

(c) Area of triangle $BOC = \frac{1}{2} \times 4 \times 4 \times \sin 45^\circ = 5.657$ [M1]

Area of octagon = 45.3 cm^2 [A1]

24. (a) $(3x + y - 3)$, $(2x + 3y)$, $(x + 4y + 5)$

Any of these two equations or equivalent [B1 each: must simplify]

$$x - 2y = 3$$

$$x - y = 5$$

$$2x - 3y = 8$$

(b) [M1]: any method to solve the two equations

[A1, A1] $x = 7, y = 2$

[B1 \checkmark] $20 \times 3 = 60 \text{ cm}^2$

Paper 2

1. (a) (i) 17 [B1]
 (ii) $-1 + 3n$ [B1]
 (iii) $-1 + 3n = 2021$ [M1 \checkmark : part (ii) answer = 2021]
 $n = 674$
 Since n is a positive integer, 2021 is a term of the sequence. [A1]
- (b) (i) $T_5 = 195$ [B1]
 (ii) $T_n = (3n-1)^2 - 1$ [M1]
 $T_n = 9n^2 - 6n$ [A1]
 (iii) $T_n = 3(3n^2 - 2n)$. Therefore, it is a multiple of 3 [B1 \checkmark \rightarrow must show factor of 3]
2. (a) 2.5 [B1]
 (b) The bus moves at a constant speed. [B1]
 (c) $\frac{1}{2} \times 10 \times 15 + 40 \times 15$ [M1: finding the area under the graph. May award M1 if students accidentally find the distance for all journey instead]
 $= 675$ m [A1]
 (d) $\frac{1}{2} \times 40 \times v = 675$ [M1 \checkmark]
 $v = 33.75$ [A1]
3. (a) $-2 < 1 - 2x \leq 5$
 $-3 < -2x \leq 4$
 $1.5 > x \geq -2$ [B1: for one correct inequality]
 [B2: correct inequalities and combined]
- (b) $5^{22} = (5^2)^{11}$
 $3^{33} = (3^3)^{11}$ [B1: attempt to change to same power 11]
 $27^{11} > 25^{11}$. Therefore, Alan's claim is wrong [B1]

$$(c) \frac{(3x-2)(x+1)}{3(3x-2)(3x+2)} \text{ [M1, M1 each for correct factorization]}$$

$$= \frac{(x+1)}{3(3x+2)} \text{ or } \frac{(x+1)}{9x+6} \text{ [A1}\checkmark\text{: cancelling the common factor from numerator and denominator]}$$

$$(d) \frac{5x}{(3x-2)^2} - \frac{2}{3x-2} \text{ [M1]} \qquad \text{OR} \quad \frac{5x(2-3x)+2(3x-2)^2}{(3x-2)^2(2-3x)} \text{ [M1]}$$

$$= \frac{5x}{(3x-2)^2} - \frac{2(3x-2)}{(3x-2)^2} \text{ [M1: equalise denominator]} \qquad \frac{3x^2-14x+8}{(3x-2)^2(2-3x)} \text{ [M1]}$$

$$= \frac{5x-6x+4}{(3x-2)^2} \qquad \frac{(2-3x)(-x+4)}{(3x-2)^2(2-3x)}$$

$$= \frac{-x+4}{(3x-2)^2} \text{ [A1]}$$

$$(e) (i) (x-4.5)^2 - 15.25 \text{ [B1, B1 for correct } p \text{ and } q \text{ each]}$$

$$(ii) -15.25 \text{ [B1}\checkmark\text{ -- the value of } q\text{]}$$

$$4. (a) \frac{480}{x} \text{ [B1]}$$

$$(b) \frac{300}{x-0.1} \text{ [B1]}$$

$$(c) \frac{480}{x} - \frac{300}{x-0.1} = 100 \text{ [M1}\checkmark\text{: part (a) -- part (b)]}$$

$$480(x-0.1) - 300x = 100x(x-0.1) \text{ [M1}\checkmark\text{: get rid of the denominator without changing the level of difficulty]}$$

$$100x^2 - 190x + 48 = 0 \rightarrow 50x^2 - 95x + 24 = 0 \text{ [A1]}$$

$$(d) \frac{95 \pm \sqrt{(-95)^2 - 4(50)(24)}}{2 \times 50} \text{ [M1 for substitution of } -b \text{ and } 2a, \text{ M1 for } b^2 - 4ac \text{]}$$

$$x = 1.6, x = 0.3 \text{ [A1, A1]} \qquad \text{(if no working shown, B1 each for correct answer)}$$

$$\text{OR } (10x-3)(5x-8) = 0 \text{ [M2]}$$

$$(e) \$1500 \text{ [B1]}$$

5. (a) In triangle CRO and triangle CPO ,

$$CO = CO \text{ (common side)}$$

$$\angle CRO = \angle CPO \text{ (tangent perpendicular to radius)}$$

$$CR = CP \text{ (radius)}$$

[B1 for two correct statements and reason, B2 for all correct statements and reason]

$\triangle CRO$ is congruent to $\triangle CPO$ (RHS) [B1 for RHS -- the congruence test must tally with the three statements used]

Accept SAS, SSS, ASA as well when student used tangents from external point concept. However the 3 statements must tally with the congruence test used.

$$(b) \sin 30^\circ = \frac{6}{CO} \text{ [M1]}$$

$$CO = 12$$

$$\text{Therefore } x = 12 + 6 = 18 \text{ [A1]}$$

$$(c) \text{ Arc length } PSR = \frac{240}{360} \times 2\pi(6) \text{ [M1]}$$

$$= 8\pi \text{ [A1]}$$

$$\text{Perimeter} = 12 + 8\pi \text{ [B1}\checkmark\text{ : } 12 + \text{arc length } PSR \text{ found]}$$

$$(d) \text{ Area of sector } AOB = \frac{60}{360} \times \pi \times 18^2 \text{ [M1]}$$

$$\text{Area of major sector } CPRS = \frac{240}{360} \times \pi(6)^2 \text{ [M1]}$$

$$\text{Shaded area} = 94.2 \text{ cm}^2 \text{ [A1]}$$

6. (a) $AD^2 = 65^2 + 70^2 - 2(65)(70)\cos 130^\circ$ [M1]
 $= 14974.367$ [M1: taking square root or s.o.i. in taking square root]
 $AD = 122 \text{ m}$ [A1]
- (b) $\frac{\sin 130^\circ}{160} = \frac{\sin \angle ACB}{65}$ [M1: using sine rule to find angle ACB]
 $\sin \angle ACB = \frac{65 \sin 130^\circ}{160}$
 $\angle ACB = 18.13$ [M1√: making sin angle ACB as subject and take sin inverse]
 $\angle BAC = 180^\circ - 18.13^\circ - 130^\circ = 31.87^\circ$ [A1]
- (c) Draw north line from C . $\angle N_2CA = 31.87^\circ$ [M1] or any method reaching to this correct angle.
 Bearing of A from $C = 360 - 31.87^\circ = 328.1^\circ$ [A1]
- (d) $\tan 20^\circ = \frac{h}{65}$ [M1] **OR** using correct sine rule
 $h = 65 \tan 20^\circ$
 $\tan \theta = \frac{65 \tan 20^\circ}{70}$ [M1 √] **OR** using correct sine rule
 $\theta = 18.7^\circ$ [A1]
7. (a) (i) $192 - 40 = 152$ [M1, A1] - Award M1 if one of the numbers is correct and attempt to subtract both numbers.
 (ii) $26.5 - 16.5 = 10$ [M1, A1] - Award M1 if one of the quartiles is correct and attempt to subtract Q_1 from Q_3 .
 (iii) School B upper quartile is 30 minutes. Therefore there are 25% of students (or 50 students) who took more than 30 minutes. [B1]
- Her statement is **incorrect** as Q_3 in school A is smaller than school B which means that fewer students who took more than 30 minutes. [B1]
- OR** from the curve, there are 28 students in school A who took more than 30 minutes. Therefore, her statement is incorrect. [B1]

$$(b) (i) \left(\frac{5}{12} \times \frac{3}{11}\right) \times 2 = \frac{5}{22} \text{ [M1,A1]}$$

M1 is awarded if $\left(\frac{5}{12} \times \frac{3}{11}\right)$ is seen.

$$(ii) \left(\frac{5}{12} \times \frac{4}{11}\right) + \left(\frac{4}{12} \times \frac{3}{11}\right) + \left(\frac{3}{12} \times \frac{2}{11}\right) \text{ [M1: at least two correct]}$$

$$= \frac{19}{66} \text{ [A1]}$$

$$(iii) \frac{7}{12} \times \frac{6}{11} \times \frac{5}{10} = \frac{7}{44} \text{ [B1]}$$

8. (a) 5.22 [B1]

(b) P2: all points plotted correctly

P1: 4 to 6 points plotted correctly

C1: smooth curve, curve passes through all the points, no 'break'

(c) $y = 1$ is seen or implied. [B1]

$1.2 < x < 3.7$ [B1√ from graph]

(d) Tangent is drawn correctly at $x = 1.5$ [B1]

Gradient = -2.75 ± 0.5 [B1]

(e) (i) A line with passes through (2,0) [B1]

A line has gradient of -1 [B1]

(ii) $x = 1.2$ or 2.6 [B1√ from graph]

$$9. (a) \frac{h}{h+80} = \frac{36}{84} \text{ [M1]}$$

$$84h = 36h + 2880$$

$$h = 60 \text{ [A1]}$$

(b) Volume of cylinder (in mm^3) = $\pi(42)^2(120)$ [M1]

Volume of big cone (in mm^3) = $\frac{1}{3}\pi(42)^2(140)$ [M1]

Volume of small cone (in mm^3) = $\frac{1}{3}\pi(18)^2(60)$ [M1]

Can award at most M1 if all workings are correct but students used diameter and not radius

Volume of frustum (in mm^3) = Volume of big cone – volume of small cone [M1 \checkmark]

$$= \frac{1}{3}\pi(42)^2(140) - \frac{1}{3}\pi(18)^2(60)$$

Total volume = Volume of cylinder + frustum = $903.27 \text{ cm}^3 = 903 \text{ cm}^3$ [A1]

Penalise overall 1 mark for issue with wrong conversion for this part.

$$(c) \frac{V_1}{V_2} = \left(\frac{h_1}{h_2}\right)^3$$

$$\frac{1}{2} = \left(\frac{h_1}{200}\right)^3 \quad [\text{M1: concept of ratio of volume and height}]$$

$$h = 159 \text{ mm} \quad [\text{A1}]$$

10. (a) Waiting rate = $2 \times \$0.22 = \0.44 [M1]

Distance rate = $\$3.50 + \frac{10000}{400} \times \0.22 [M1: for flag rate and attempt to use rate:

every 400m is \$0.22]

Total fare = \$9.44 [A1]

(b) Price before discount = $\$27.84 \div 0.95$ [M1] = \$29.305

Price before surcharge = $\$29.305 \div 1.3 =$ [M1 \checkmark] = \$22.542

Waiting rate = $7 \times \$0.22$ [M1] = \$1.54

Price excluding waiting rate = $\$22.542 - \$1.54 = \$21$

$$3.50 + \frac{10000}{400} \times \$0.22 + \frac{x}{300} \times \$0.25 = \$21 \quad [\text{M1 } \checkmark]$$

$$\frac{x}{300} \times \$0.25 = \$12 \quad [\text{M1 } \checkmark]$$

$$x = 14400 \text{ Accept}$$

Total distance = $1 + 10 + 14.4$ [M1 \checkmark : 1 + 10 + the remaining km] = 25.4 km

Average speed = $\frac{25.4}{0.5} = 50.8 \text{ km/h}$ [A1] (Accept between 50.2 and 50.8 km/h)

