

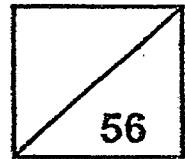

**Rosyth School**  
**Semestral Assessment 1 2018**  
**SCIENCE**  
**Primary 6**



Name: \_\_\_\_\_

Total  
Marks:

Class: Pr 6 \_\_\_\_\_

Register No. \_\_\_\_\_

Duration: 1 h 45 min

Date: 9 May 2018

Parent's Signature: \_\_\_\_\_

---

## Booklet A

**Instructions to Pupils:**

1. Do not open the booklets until you are told to do so.
2. Follow all instructions carefully.
3. This paper consists of 2 booklets - Booklet A and Booklet B
4. For questions 1 to 28 in Booklet A, shade the correct ovals on the Optical Answer Sheet (OAS) provided using a 2B pencil.
5. For questions 29 to 40, give your answers in the spaces given in the Booklet B.

\* This booklet consists of 24 printed pages (including cover page).

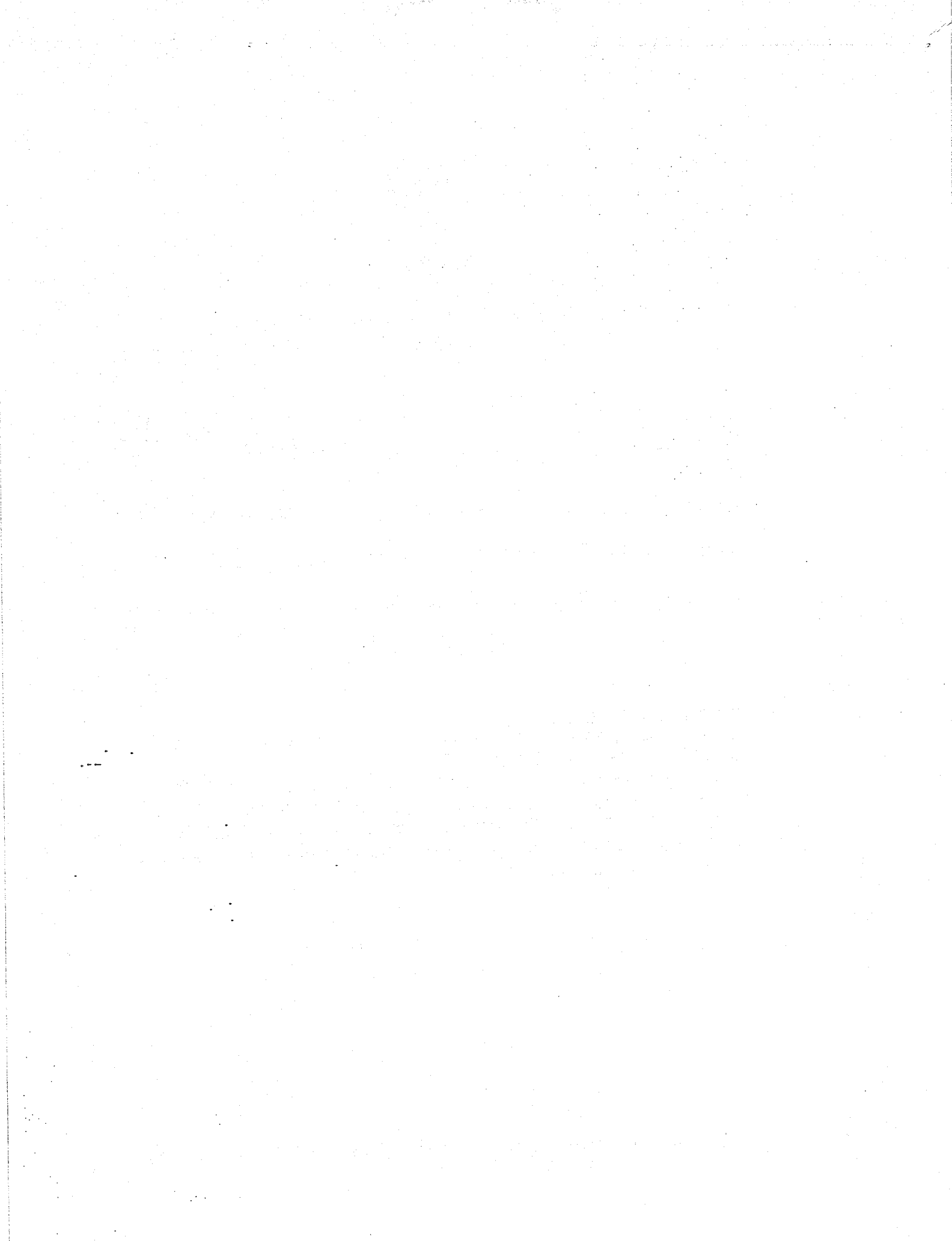

**Part I**

For each question from 1 to 28, four options are given. One of them is the correct answer. Make your choice (1, 2, 3 or 4). Shade the correct oval (1, 2, 3 or 4) on the Optical Answer Sheet. **(56 Marks)**

1. Dominic wanted to keep a grasshopper as a pet in a bottle. He thought of three possible ways A, B and C to keep the grasshopper.

The table below shows the three conditions.

	A	B	C
Plant	No	Yes	No
Temperature	28 °C	28 °C	32 °C
Lid with holes	No	Yes	Yes

Which one of the following is correct?

	Most suitable way to keep a grasshopper	Least suitable way to keep a grasshopper
(1)	A	B
(2)	B	C
(3)	B	A
(4)	A	C

2. The diagram below shows a flowering plant.

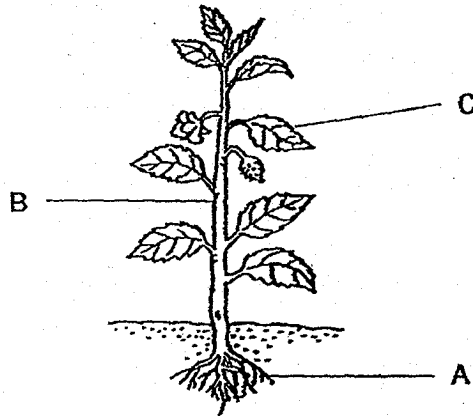

Which of the plant parts, A, B and C show the respective functions correctly?

	Part A	Part B	Part C
(1)	To trap sunlight to make food for the plant.	To support the plant to receive sunlight.	To absorb water for the plant.
(2)	To absorb water for the plant.	To support the plant to receive sunlight.	To trap sunlight to make food for the plant.
(3)	To absorb water for the plant.	To hold the plant firmly to the ground.	To trap sunlight to make food for the plant.
(4)	To hold the plant firmly to the ground.	To trap sunlight to make food for the plant.	To absorb water for the plant.

3. Study the diagram below.

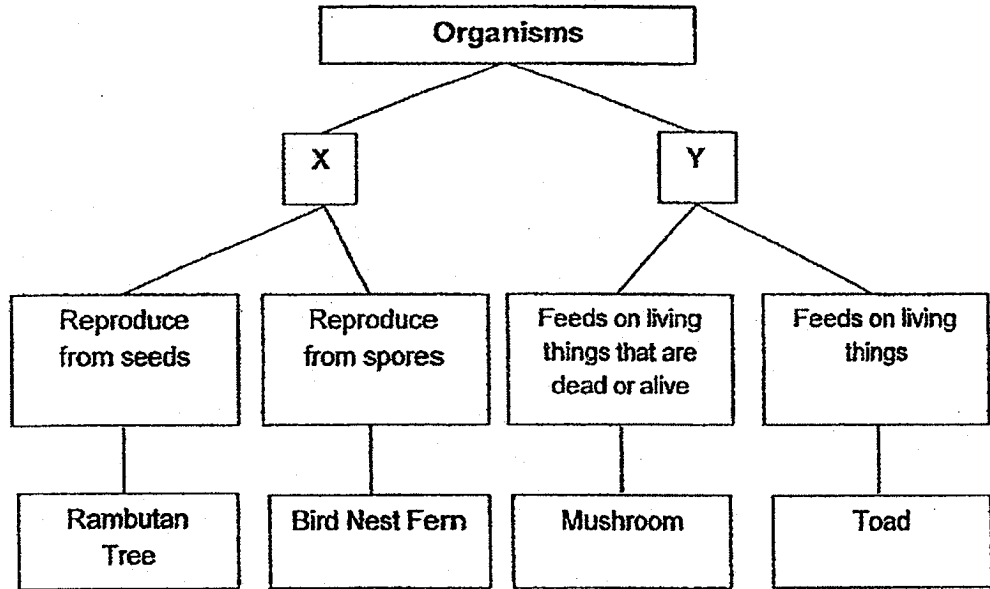

Which one of the following can headings X and Y be?

	X	Y
(1)	Plant	Animal
(2)	Lives on land	Lives in water
(3)	Has chloroplasts	Does not have chloroplasts
(4)	Cannot move from place to place	Can move from place to place

4. The diagram below shows the cross-section of a flower.

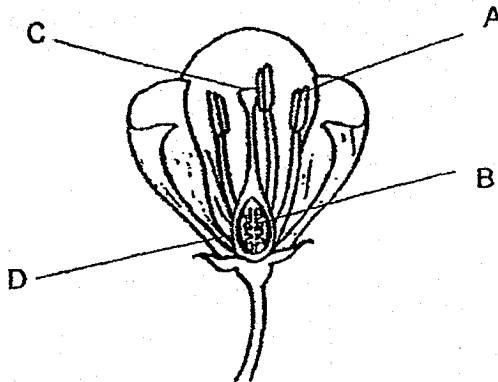

Cross-section of a flower

Which parts of the flower will develop into parts of the fruit after fertilisation?

- (1) A and B only  
(2) A and C only  
(3) B and C only  
(4) B and D only
5. Study the transfer of energy below.

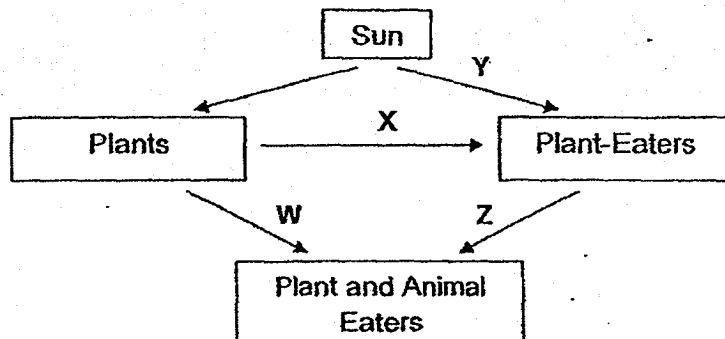

Which one of the following shows the direct transfer of energy incorrectly?

- (1) W  
(2) X  
(3) Y  
(4) Z

6. Bella used the set-up shown below to find out if hydrilla affects the amount of carbon dioxide in the water at different times of the day.

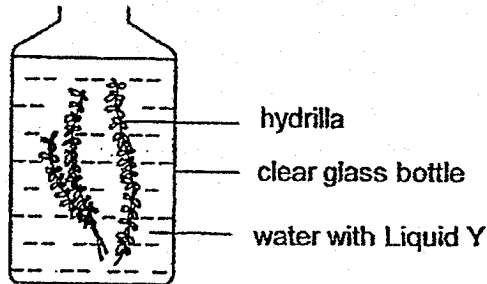

She placed the set-up near the window and added a few drops of Liquid Y to the water. The table shows how Liquid Y changes the colour as it mixed with the different amount of carbon dioxide produced in the water.

Amount of carbon dioxide in the water (cm <sup>3</sup> )	Less than normal	Normal	More than Normal
Colour of water with Liquid Y	Blue	Purple	Red

What is the colour of the water with Liquid Y at noon and midnight respectively?

- (1) Blue and red  
 (2) Red and blue  
 (3) Red and purple  
 (4) Purple and blue

7. Which of the following statements correctly compare the difference between inhaled and exhaled air?

- A: Inhaled air has less water vapour.
- B: Inhaled air has less carbon dioxide.
- C: Exhaled air has less oxygen.
- D: Exhaled air has less water vapour.

(1) A and B only

(2) B and D only

(3) A, B and C only

(4) A, C and D only

8. The graph below shows how gases are transported in the blood through blood vessels A, B, C, D, E, F and G in the circulatory systems of a fish and man.

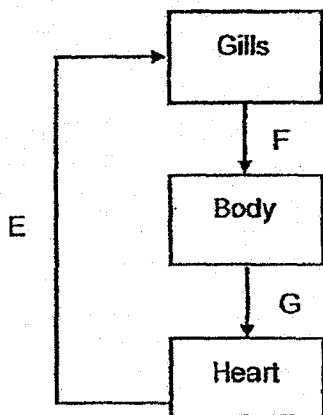

Circulatory system of a fish

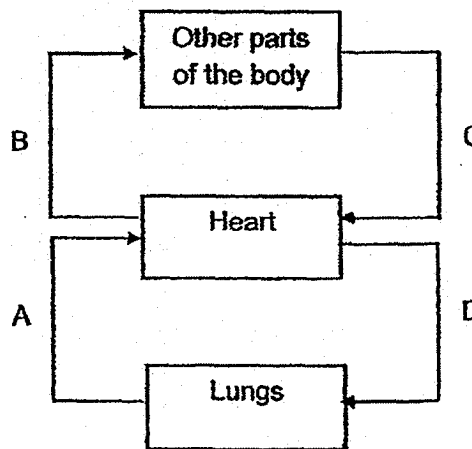

Circulatory system of a human

Based on the diagrams above, which of the following statement(s) is/are correct?

- A: The blood vessels A, B, and F carry blood rich in oxygen.
- B: The blood vessels C, D and E carry blood rich in carbon dioxide.
- C: The heart is needed to pump blood from the body of the fish to the gills.

(1) A only

(2) A and B only

(3) B and C only

(4) A, B and C



9. The chart below shows some substances X and Y are transported in the human body.

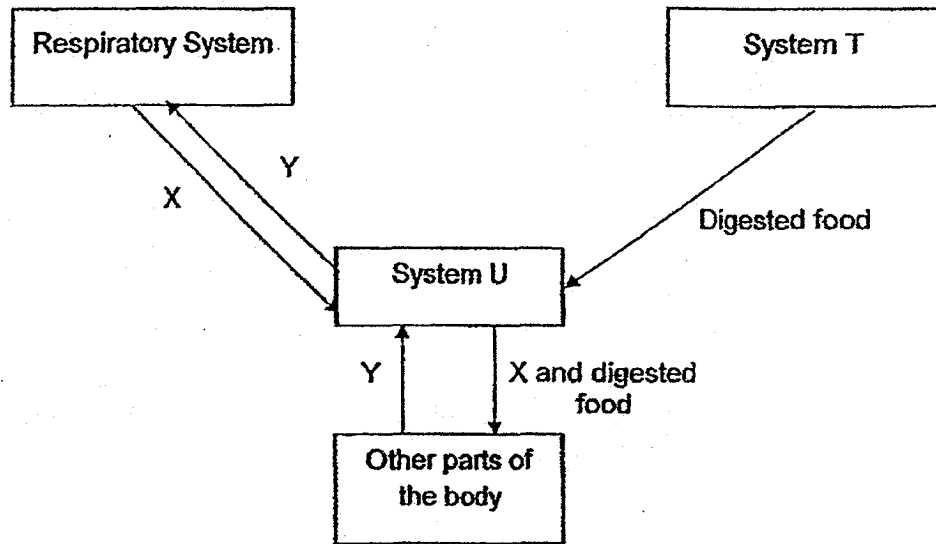

Which one of the following correctly identifies substances X and Y and systems T and U?

	X	Y	System T	System U
(1)	Carbon dioxide	Oxygen	Digestive System	Circulatory System
(2)	Carbon dioxide	Oxygen	Circulatory System	Digestive System
(3)	Oxygen	Carbon dioxide	Circulatory System	Digestive System
(4)	Oxygen	Carbon dioxide	Digestive System	Circulatory System

10. Which one of the graphs correctly shows the interaction between two physical factors in an environment?

(1)

Temperature of pond water ( $^{\circ}\text{C}$ )

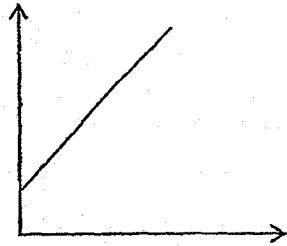

Intensity of light shining on the pond water (lux)

(2)

Amount of soil (g)

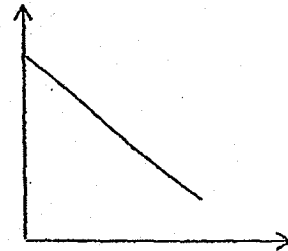

Amount of rainfall (ml)

(3)

Amount of water in the soil (ml)

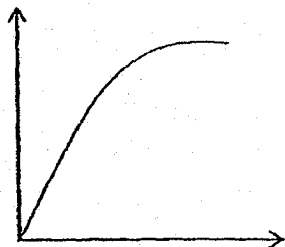

Intensity of light (lux)

(4)

Temperature of pond water ( $^{\circ}\text{C}$ )

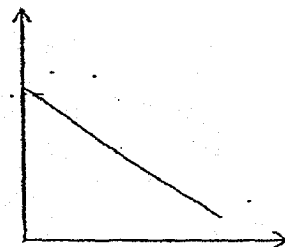

Intensity of light shining on the pond water (lux)

11. Study the table below.

Organisms	Number of organisms
Frog	3
Catfish	4
Duckweed	20
Butterfly	3
Guppy	2
Caterpillar	2
Tadpole	3
Water Hyacinth	4
Arrowhead Plant	3

What is the correct number of populations and producers living together?

	Number of populations	Number of food producers
(1)	6	2
(2)	7	2
(3)	7	3
(4)	9	3

12. The diagram below shows a plant. Part X of the plant is thick, green and waxy.

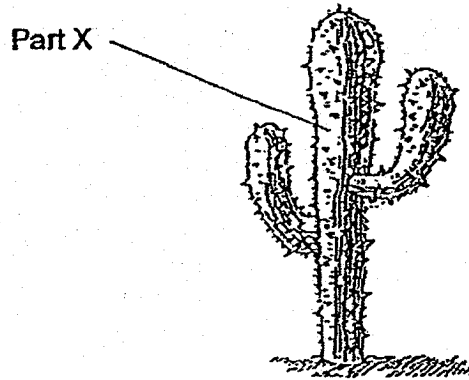

Which of the following shows how Part X helps the plant to survive in a desert?

A: It helps to make food.

B: It helps to store water.

C: It helps to reduce water loss.

D: It helps to anchor the plant firmly to the soil.

(1) B only

(2) A and B only

(3) A, B and C only

(4) A, B, C and D

13. The food web below shows the food relationships among some organisms.

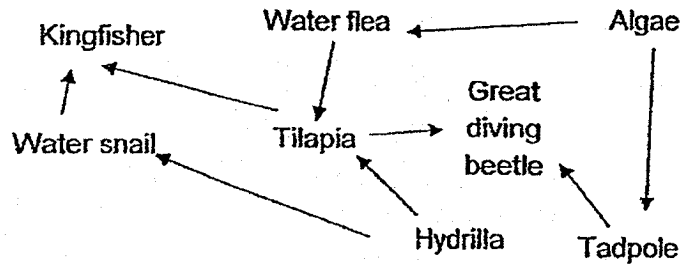

Based on the above food web, which of the following statements are true?

- A: There are four prey.
- B: There are three predators.
- C: There are four plant-eaters.
- D: There are two plant and animal eaters.

(1) A and D only

(2) C and D only

(3) A, B and C only

(4) B, C and D only

14. There are many tall trees in Forests Y and Z. The table below shows the conditions of the forest floor in the two forests.

Conditions of Forest Floor	Forest Y	Forest Z
Amount of light reaching the floor	Moderate	Very Little
Amount of nutrients in the topsoil of forest floor	Large	Very Little

Based on the information above, which one of the following options are the correct observation and explanation for the organisms found in each forest?

	Observation	Explanation
(1)	Fewer small plants grow on the Forest Floor Y than Forest Floor Z.	There is enough nutrients in the topsoil.
(2)	More small plants grow on Forest Floor Y than Forest Floor Z.	The plants are able to make more food.
(3)	More tall-trees grow in Forest Z than Forest Y.	There is not enough nutrients in the topsoil.
(4)	Fewer tall trees grow in Forest Z than Forest Y.	There is very little light reaching Forest Floor Z.

15. Shane had four sheets A, B, C and D made of different materials. He wanted to find out the amount of light passing through the four sheets. He arranged the sheets as shown below in the two set-ups, X and Y.

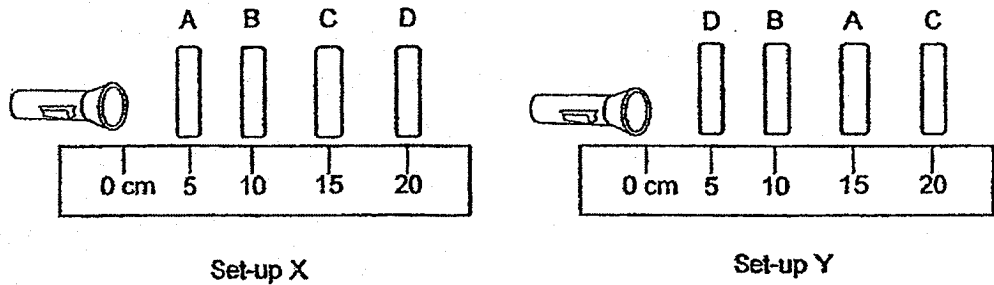

He measured the distance travelled by the light for each set-up and the results are shown in the bar graph below.

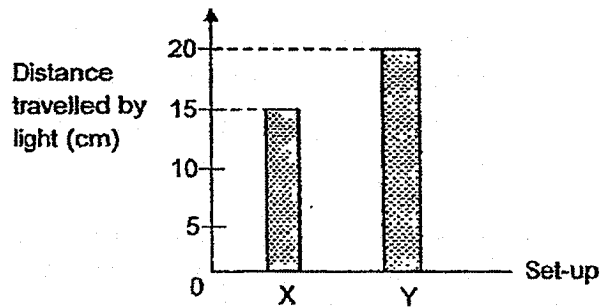

Which one of the following statements is correct?

- (1) Sheet C does not allow light to pass through.
- (2) Sheet D does not allow light to pass through.
- (3) Sheets A and B do not allow light to pass through.
- (4) Sheet A allows more light to pass through than Sheet C.

16. A torchlight was placed at the 1m mark of a ruler. The torchlight shone at an object that was placed at the 3m mark of a ruler as shown below. A shadow was cast on the screen.

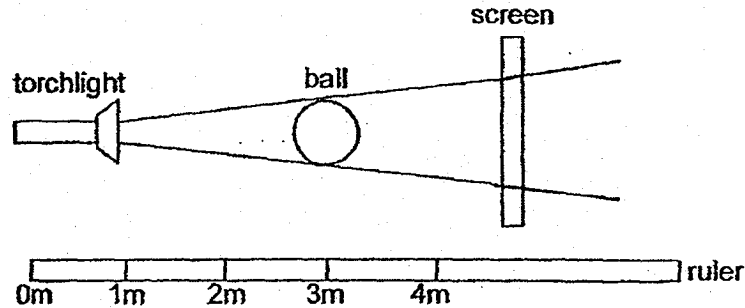

Which one of the following actions would cause a larger shadow to be formed on the screen?

- (1) Move the ball closer to the screen.
  - (2) Move the screen closer to the ball.
  - (3) Move the screen further away from the ball.
  - (4) Move the torchlight further away from the ball.
17. Azus carried out an experiment. He heated up a mug of coffee in a microwave. He then took out the mug from the microwave and placed it in a basin of cold water as shown below.

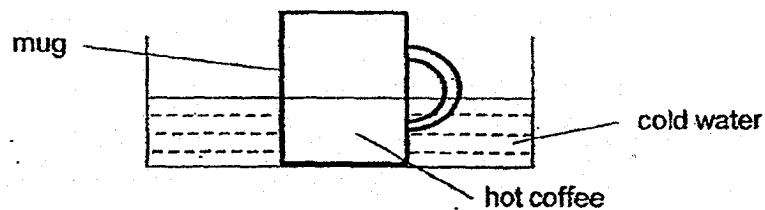

Which one of the following correctly shows the objects in the above set-up had gained heat or lost heat before it reaches room temperature?

	hot coffee	mug	cold water
(1)	lost heat	lost heat	gained heat
(2)	gained heat	gained heat	lost heat
(3)	lost heat	gained heat	gained heat
(4)	gained heat	lost heat	gained heat



18. Grace coated the 4 ends of different materials (W, X, Y, and Z) with some wax. Next, she heated the other ends of each rod over a candle flame. She measured the time taken for the wax to melt completely. Her results are shown in the bar graph below.

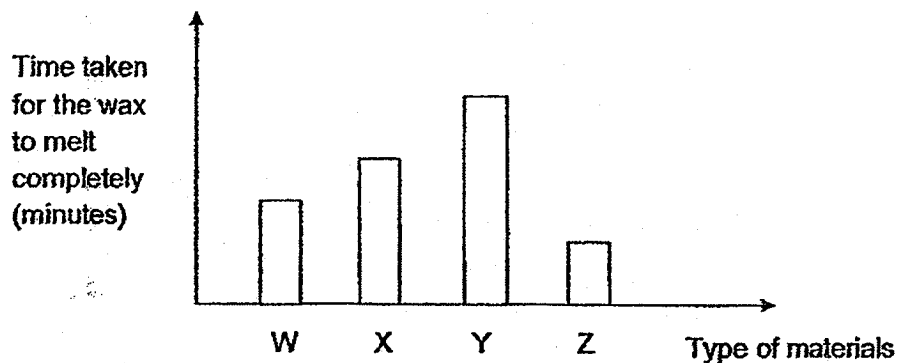

Which one of the following variables should she keep the same for a fair experiment?

- A: Size of rods
- B: Amount of wax
- C: Intensity of the flame
- D: Time taken for the wax to melt completely

- (1) A and B only
- (2) C and D only
- (3) A, B and C only
- (4) A, B, C and D

19. Study the flow chart below.

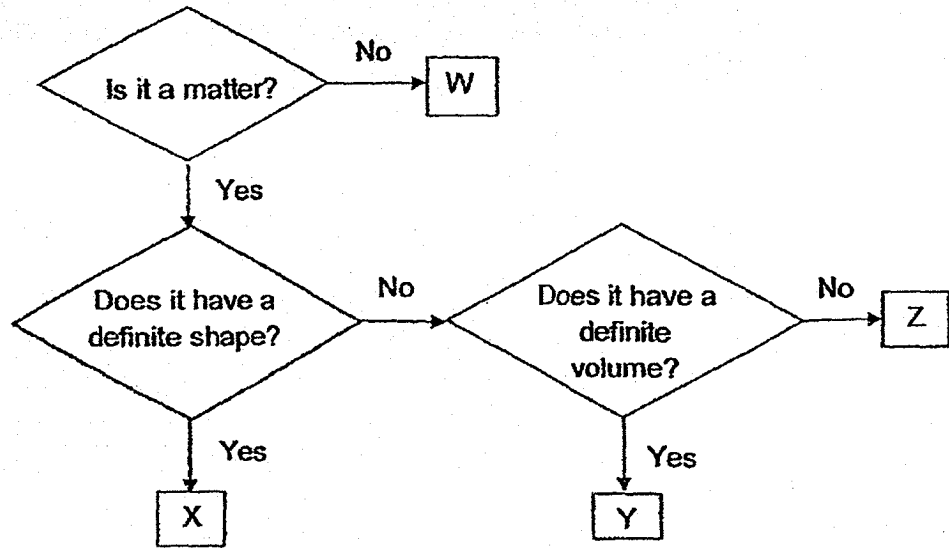

Which one of the following represents steam in the flow chart?

- (1) W
- (2) X
- (3) Y
- (4) Z

20. Four metal blocks were heated to a temperature of 80 °C. Each block was dropped into a beaker of water as shown below. Each beaker contained a different amount of water, at a different temperature.

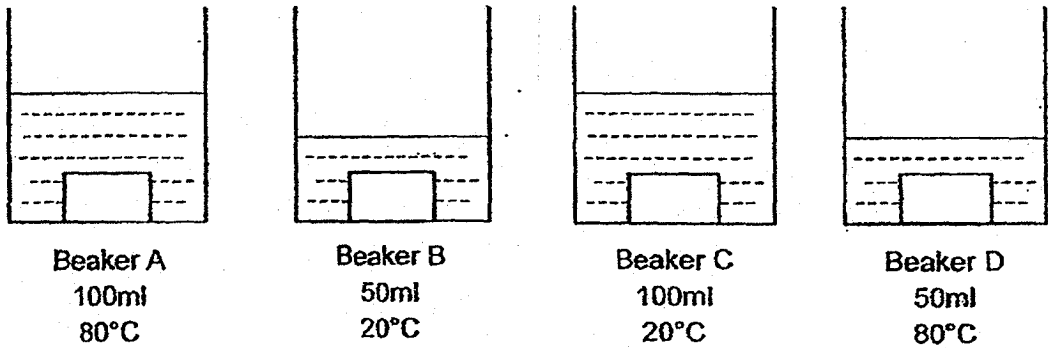

In which beaker would the water show the greatest rise in temperature?

- (1) Beaker A
- (2) Beaker B
- (3) Beaker C
- (4) Beaker D

21. Jenny heated some ice cubes in a beaker using a hot pan. All the ice melted after 10 minutes. After 10 minutes, the water started to boil. She then switched off the hot pan 10 minutes later.

Which of the following graphs shows the results of Jenny's experiment correctly?

(1)

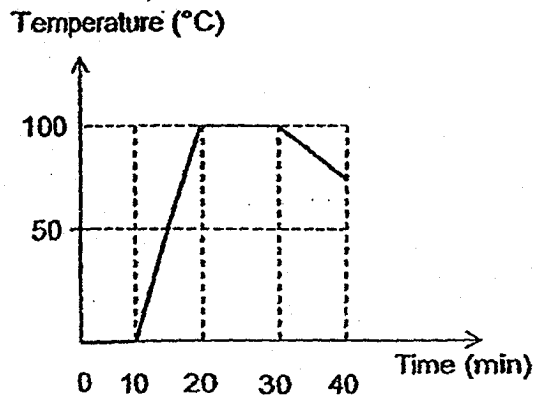

(2)

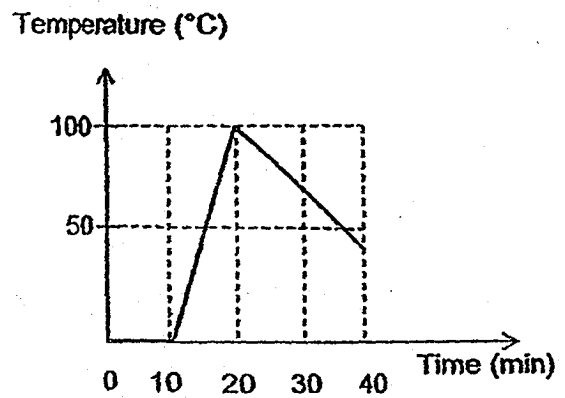

(3)

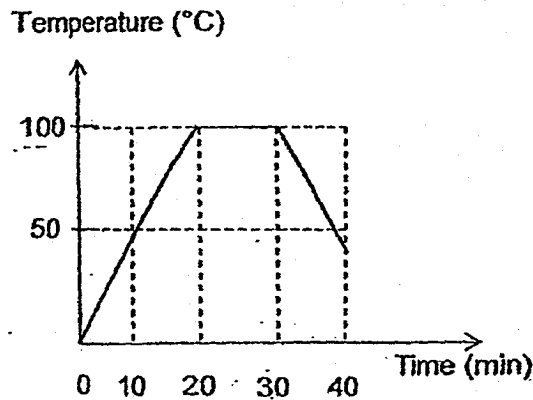

(4)

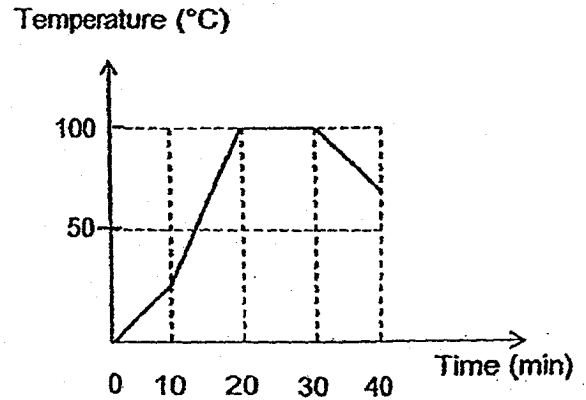

22. Which of the following diagrams correctly shows how rivers play a part in the water cycle?

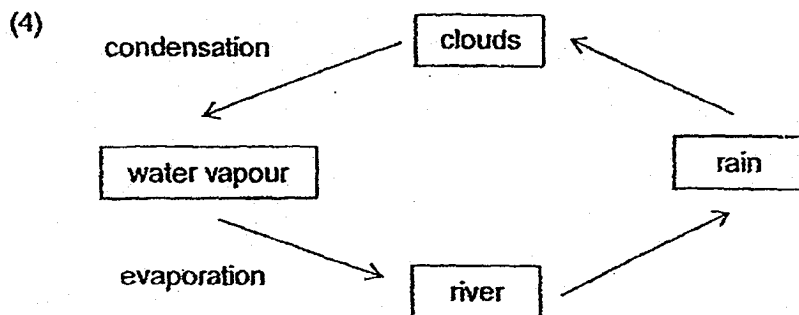
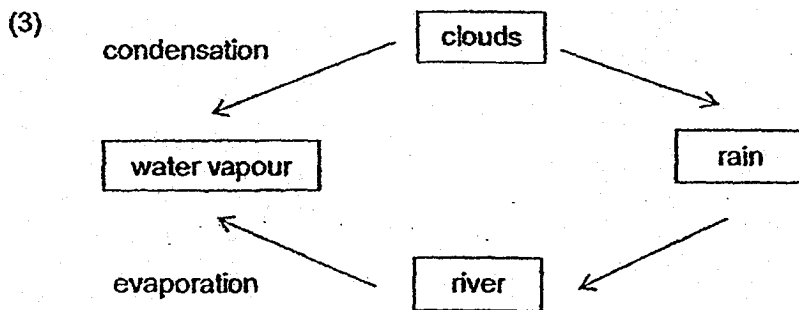
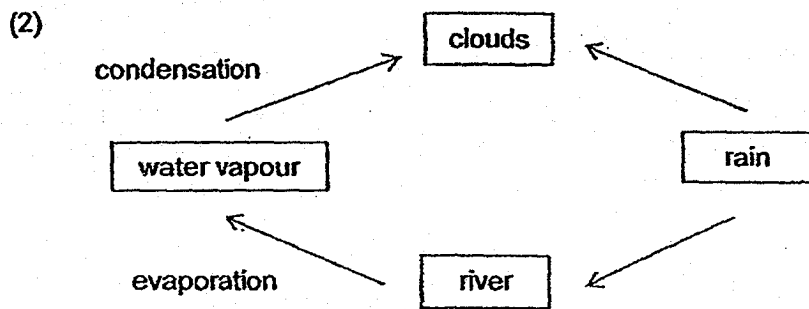
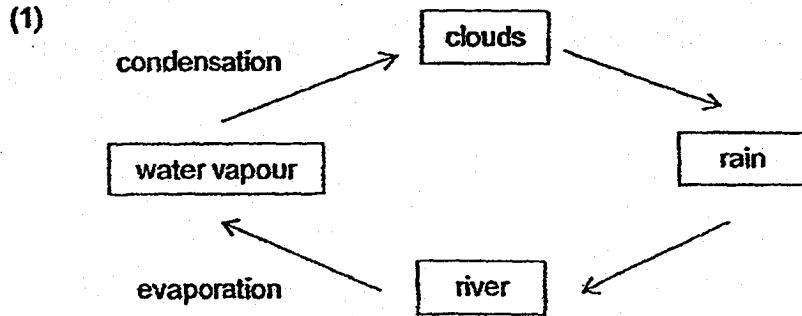

23. Ben released a ball at position W in the plastic bowl shown below. The ball rolled to position X and then to position Y where it rolled back.

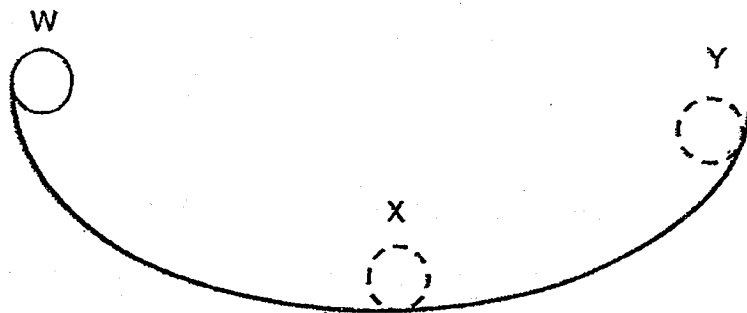

Which of the following shows the energy conversion when the ball rolled from X to Y?

- (1) kinetic energy  $\rightarrow$  heat energy + sound energy
  - (2) potential energy  $\rightarrow$  sound energy + heat energy
  - (3) kinetic energy  $\rightarrow$  potential energy + heat energy + sound energy
  - (4) potential energy  $\rightarrow$  kinetic energy + sound energy + heat energy
24. Janice wanted to find out if gravitational potential energy of a car affects the distance it travelled.

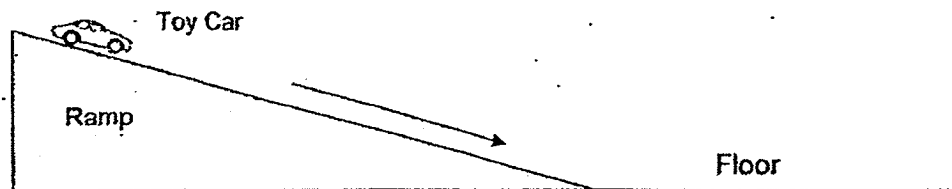

Which one of the following variables could be a changed variable for the above investigation?

- (1) Size of the floor
- (2) Mass of the toy car
- (3) Surface texture of the ramp.
- (4) Amount of force applied to push the car



26. Study the diagram below carefully.

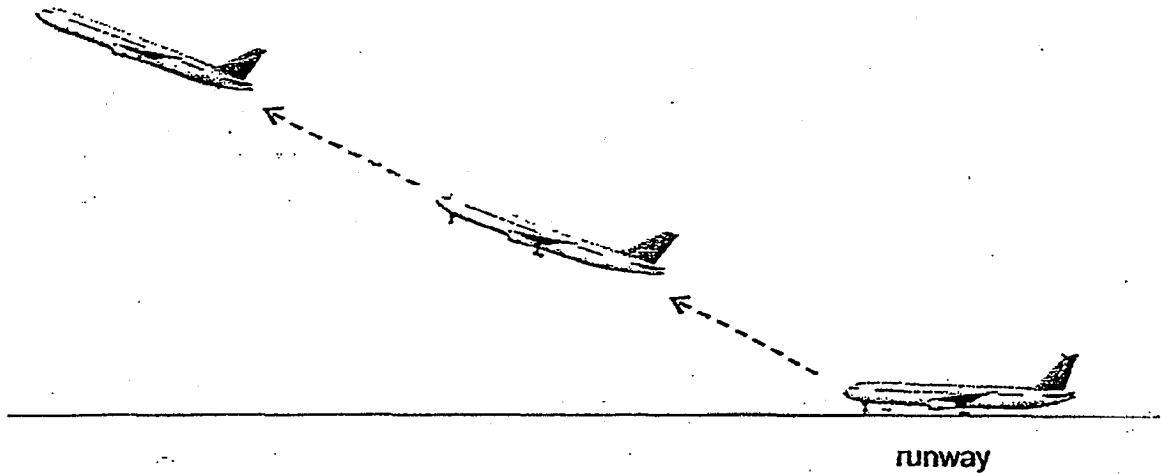

As the plane takes off from the runway as shown in above diagram, what forces are acting on the plane?

W: Frictional Force

X: Magnetic Force

Y: Gravitational Force

Z: Elastic Spring Force

(1) W and X only

(2) W and Y only

(3) W, Y and Z only

(4) X, Y and Z only

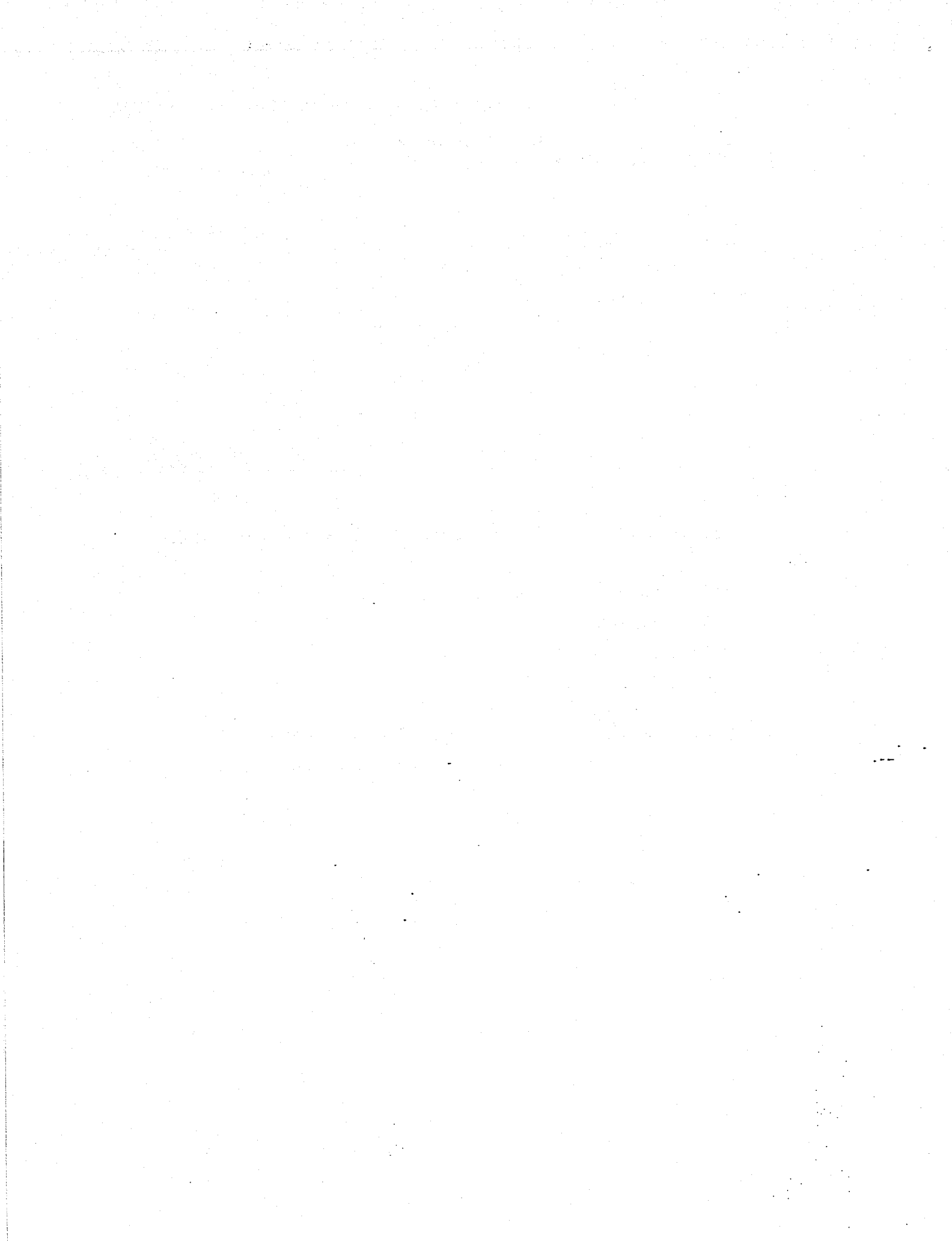



27. Alan used the set-up below to study four types of springs, A, B, C and D.

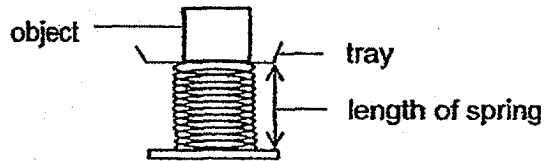

He placed an object on each spring A, B, C and D. He measured the length of the spring decreased. The results are shown in the graph below.

Springs	Mass of objects (g)	Length of spring decreased (cm)
A	10	1
B	10	2
C	10	3
D	10	0

Using the same set-up Alan wanted to compare the mass of the two apples below.

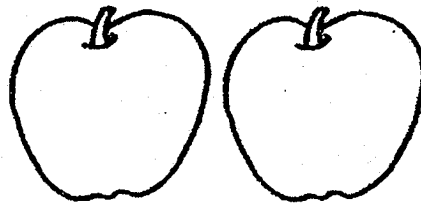

Which spring, A, B, C or D, is the most suitable for his set-up?

- (1) A
- (2) B
- (3) C
- (4) D

28 Ramsy has four different toy parachutes, W, X, Y and Z.

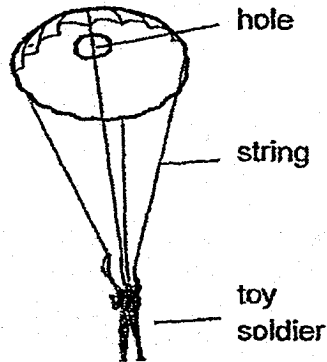

The details of the four toy parachutes are given in the table.

Parachute	Area of hole (cm <sup>2</sup> )	Length of string (cm)	Mass (g)
W	1	5	30
X	1	10	15
Y	1	10	30
Z	4	5	15

Ramsy predicted that the length of string of a toy parachute does not affect the time needed for it to fall to the ground.

Which pair of toy parachutes should he use to test his prediction?

(1) W and X

(2) W and Y

(3) X and Z

(4) Y and Z

END OF BOOKLET A



**Rosyth School**  
**Semestral Assessment 1 2018**  
**SCIENCE**  
**Primary 6**

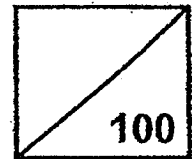

Name: \_\_\_\_\_

Total  
Marks:

Class: Pr 6 \_\_\_\_\_

Register No. \_\_\_\_\_

Duration: 1 h 45 min

Date: 9 May 2018

Parent's Signature: \_\_\_\_\_

---

---

## Booklet B

Instructions to Pupils:

1. For questions 29 to 40, give your answers in the spaces given in Booklet B.

	Maximum	Marks Obtained
Booklet A	56 marks	
Booklet B	44 marks	
Total	100 marks	

\* This booklet consists of 15 printed pages (including cover page).

**Part II**

For questions 29 to 40, write your answers in the space provided. **(44 Marks)**

---

29. Study the flowchart below.

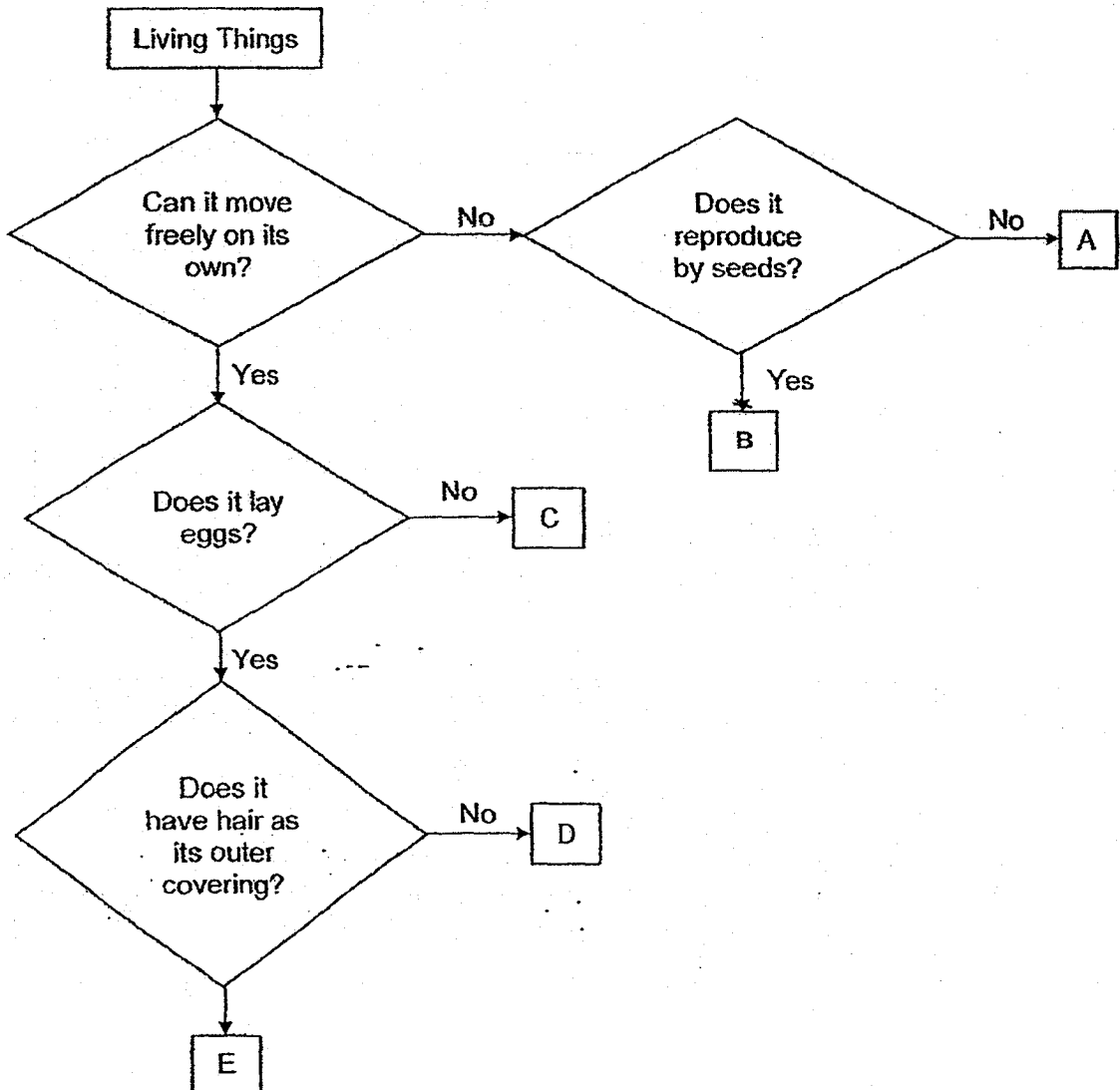

(a) What are the characteristics of Organism B? [1]

---

---

Q29 continues on page 2

(b) Can organism D be a mammal? Explain why. [1]

---

---

---

(c) Which organisms A, B, C or D, represent the following living things? [2]

(i) Grasshopper: \_\_\_\_\_ (ii) Rose Plant: \_\_\_\_\_

30. Study the diagrams below.

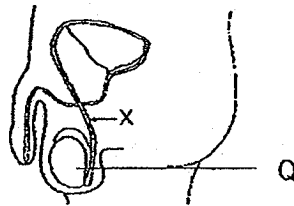

Diagram 1

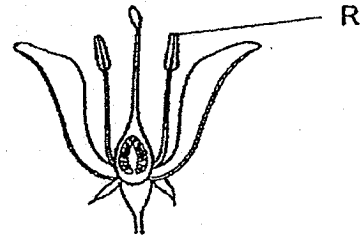

Diagram 2

(a) Write a similarity between the function of Parts Q and R. [1]

---

---

(b) Describe how insect pollination occurs. [2]

---

---

---

---

31. Felicia planted a green pea as shown below.

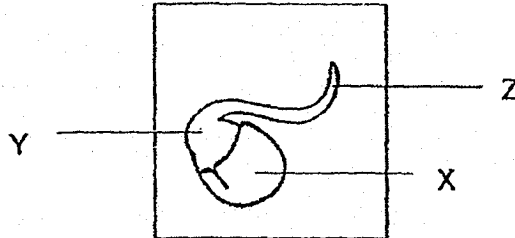

(a) Which part X, Y or Z provides the seed with energy to germinate? [1]

---



---

Felicia then decided to investigate the conditions required for seeds to germinate. She put 15 seeds on a cotton wool in each petri-dish. She watered them with the same amount of water daily. She then placed each dish at three different locations as shown in the table below.

		Number of Seeds germinated			
Day		Day 1	Day 2	Day 3	Day 4
Location of petri-dish					
Dark Cupboard		0	6	9	13
Air-conditioned Room		0	3	6	9
Freezer		0	0	0	0

(b) Based on results in the table, which is the most suitable place for the seeds to germinate? Give a reason for your choice. [1]

---



---

(c) After a week, Felicia found that all the seedlings in the dark cupboard had died. Explain why. [1]

---



---

32. The diagram below shows how four organisms, R, S, T and U, interact with one another in a natural environment. The arrows in the diagram show the direction of the flow of energy.

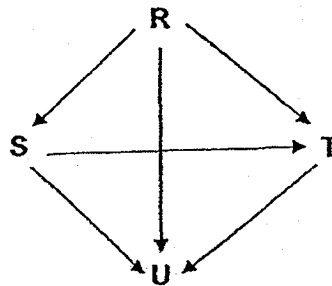

- (a) Use the letters R, S, T or U to identify the following organism. [2]

(i) Food Producer: \_\_\_\_\_

(ii) Decomposer: \_\_\_\_\_

Kelly wanted to study the conditions for decomposers to reproduce quickly. She took two similar cans of sardines and opened one of them. She left both the opened and sealed cans of sardines on a table. After a few days, she observed that the sardines in the opened can have turned bad while the one in the sealed can was fresh upon opening.

- (b) Explain why the sardines in the sealed can did not turn bad after a few days. [1]

\_\_\_\_\_

\_\_\_\_\_

- (c) Next, Kelly had two slices of bread. Describe what she should do to show that moisture caused the decomposers to reproduce faster. [1]

\_\_\_\_\_

\_\_\_\_\_

33. The table below shows how some animals living in the same habitat depend on the different parts of the tree for food. The (✓) shows the parts of the tree that the organisms depend on them for food.

Parts of a tree Animals	Bark	Leaf	Flower	Fruit
Bee			✓	
Bird				✓
Beetle	✓			
Caterpillar		✓		
Squirrel				✓
Termite	✓			

- (a) If a large number of bees is destroyed by pest controllers, which populations will be affected first? Explain your answer. [2]

---



---



---

- (b) Explain the advantage of the plant-eaters eating different parts of the tree. [1]

---



---



34. The picture below shows Animal W.



Animal W is adapted to extreme desert conditions in the desert. To cope with the extreme heat in the desert, it has a white coat in the summer but in the winter the coat turns brownish-grey. Animal W rests during the hot day in deep holes dug out in the sand. It is a herbivore and lives in a herd.

(a) How does their behavioural adaptation benefit the Animal W? Provide two benefits below. [2]

(i) Benefit 1: \_\_\_\_\_  
\_\_\_\_\_

(ii) Benefit 2: \_\_\_\_\_  
\_\_\_\_\_

(b) How does the change in the colours of Animal W's coat help it adapt to the extreme temperature in summer and winter? [2]

\_\_\_\_\_  
\_\_\_\_\_

(c) Using the information above, Animal W rarely drinks but it is able to survive in the hot desert. Suggest a possible reason. [1]

\_\_\_\_\_  
\_\_\_\_\_

35. Sue set up an experiment as shown below to compare a property of three planks, A, B and C which are made of different materials.

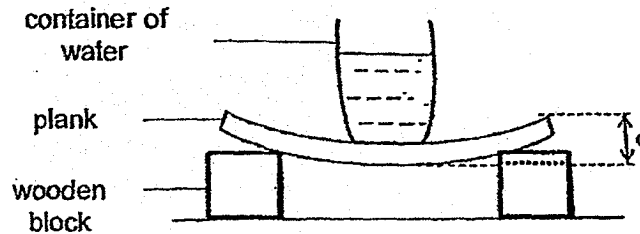

For each plank, she added  $40 \text{ cm}^3$  of water into the container and measured the distance  $d$ . Her results are shown below.

Plank	Amount of water added into the container ( $\text{cm}^3$ )	$d$ (mm)
A	40	28
B	40	39
C	40	15

- (a) Based on Sue's experiment, which plank, A, B or C, is the most suitable for making a bridge? Explain your answer. [2]

---



---



---

Sue repeated her experiment with the planks A, B and C. This time, to keep the distance  $d$  equal, she added different amount of water into the container.

- (b) Name the plank with the most and least amount of water added. [1]

Most amount of water: Plank \_\_\_\_\_

Least amount of water: Plank \_\_\_\_\_

36. An object was placed in a shoe box with two openings. One opening was for the light to enter and the other opening was for the observer to look inside the black box.

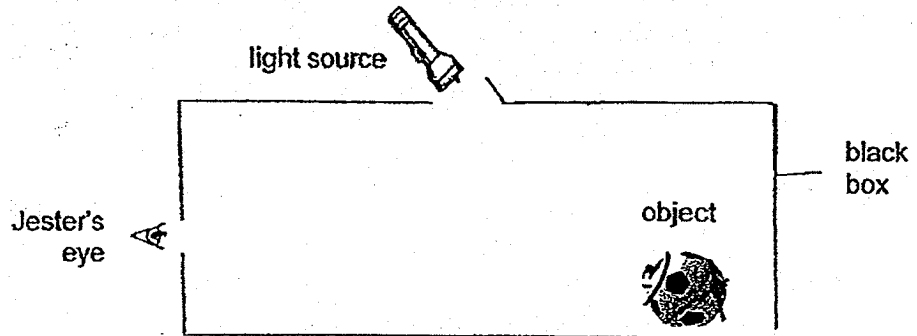

- (a) In the diagram above draw the path of light so that Jester can see the object. [1]
- (b) State two properties of light that enabled Jester to see the object. [2]

---

---

37. The following set-up as shown in the diagram below is used to obtain pure water.

As sunlight shines onto the glass cover, water droplets are formed on the underside of the glass as shown in the set-up above. Water droplets then run downwards and drip into an outlet at the base of the set-up. The water droplets are collected and stored as pure water for drinking.

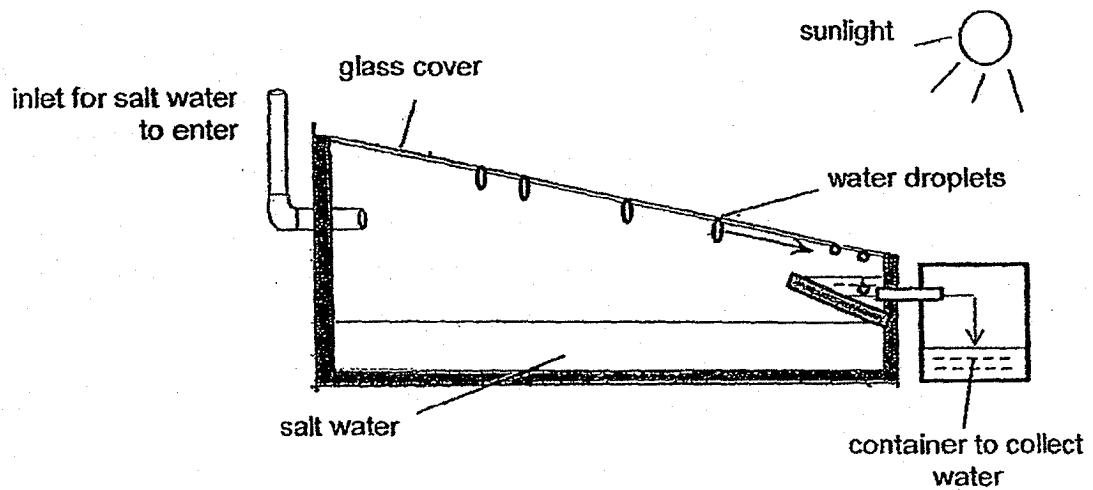

- (a) Name the process that causes the water droplets to form on the glass. [1]

---

- (b) Based on the set-up above, explain how water is collected. [2]

---

---

The amount of water that is collected is recorded at different times of the day in the table as shown below.

Time	Amount of sunlight (lux)	Amount of water collected (cm <sup>3</sup> )
8am	100	30
12pm	400	50
4pm	80	20

- (c) What is the relationship between the amount of water collected and the amount of sunlight? [1]

---

---

38. Molly hung two wet identical cloths, A and B, each on a laundry line in the garden. Cloth A was spread out while cloth B was folded in half as shown in the diagram below.

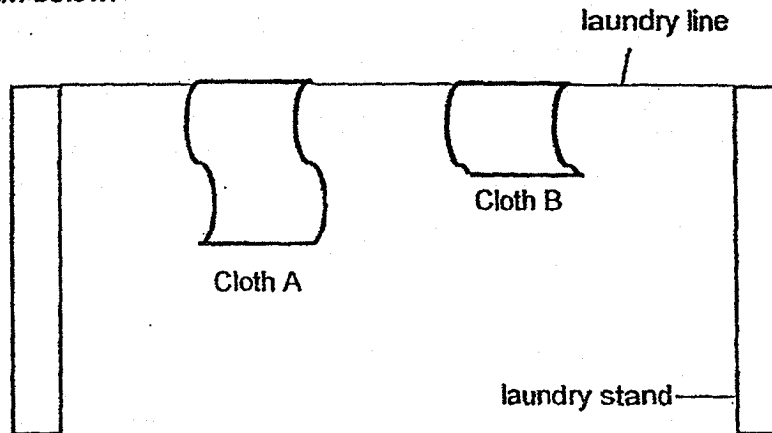

- (a) Which of the two cloths A or B will dry faster? Explain your answer. [2]

---

---

---

---

- (b) Apart from the answer in (a) suggest two other ways to dry cloth B faster. [2]

---

---

---

---

- (c) What should Molly do to make sure that her results are reliable? [1]

---

---

39. Ahmad made a simple set-up of a hydro-electric power station as shown in the diagram below. The running water turns the blades in the turbine so that electricity is produced by the generator.

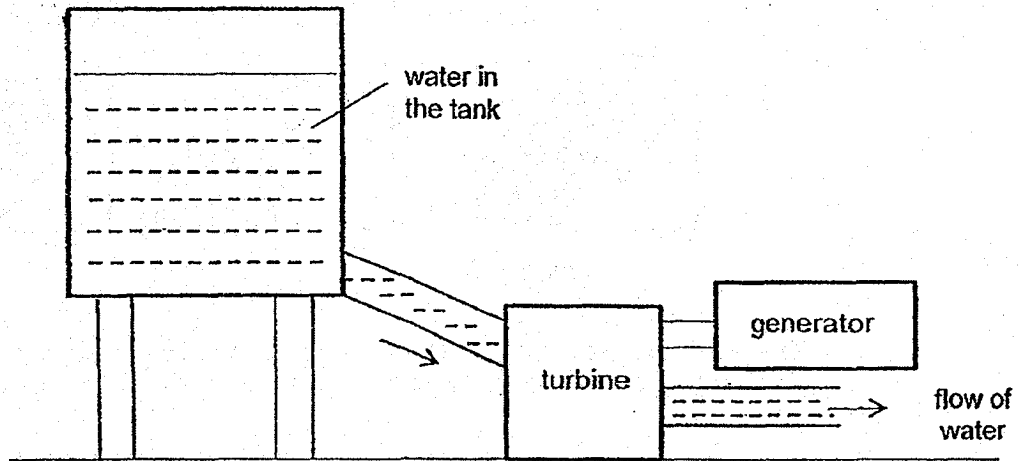

- (a) Fill in the main form of energy in the box below. [1]

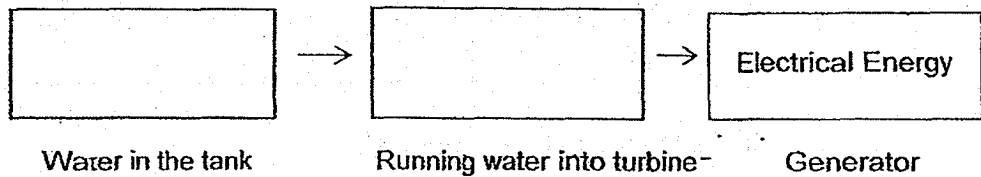

Actual hydro-electric power stations are built such that the height of the water tank is above the turbine.

- (b) Give one advantage for building the water tank at a higher level than the turbine. Explain your answer [2]

Advantage: \_\_\_\_\_

\_\_\_\_\_

Reason: \_\_\_\_\_

\_\_\_\_\_

40. An experiment was set up as shown in the diagram below. Mr Wong has three identical ramps of the same height with three different surfaces, A, B and C. Surfaces B and C were painted with a different number of thick strips of white paint.

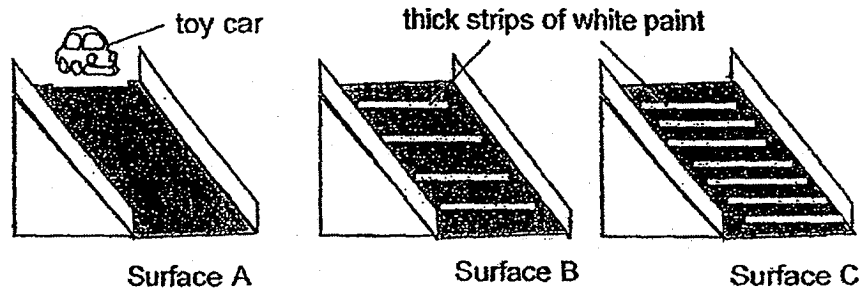

The three toy cars were released along the 3 surfaces at the same time. The table below shows the average time taken by each car to reach the bottom of the ramp.

	Surface		
	A	B	C
Time taken (s)	3.1	4.8	6.2

- (a) What is the aim of the experiment? [1]

---



---

- (b) What is the purpose of the set-up with surface A? [1]

---



---



- (c) Name one force acting on the toy car as it travelled along the 3 surfaces. [1]

---

---

- (d) From the experiment, which surface A, B or C should be used to make the road near schools safer for the driver? Explain your answer. [1]

---

---

**END OF PAPER**



**EXAM PAPER 2018(P6)**

**SCHOOL : ROSYTH**

**SUBJECT : SCIENCE**

**TERM : SA1**

Q1	Q2	Q3	Q4	Q5	Q6	Q7	Q8	Q9	Q10
3	2	3	4	3	1	3	4	4	1
Q11	Q12	Q13	Q14	Q15	Q16	Q17	Q18	Q19	Q20
3	3	3	2	1	3	1	3	4	2
Q21	Q22	Q23	Q24	Q25	Q26	Q27	Q28		
1	1	3	2	4	2	3	2		

**29)a)Organism B is a living thing that cannot move freely on its own and reproduces by seeds.**

**b)No. Organism D does not have hair as its outer covering but mammals have hair as their outer covering.**

**c)i)Grasshopper : D**

**ii)Rose Plant : B**

**30)a)Both parts Q and R produce the male reproductive cell.**

**b)When the insect/ animal enters the flower, its hairy body rubs against the anther and the pollen grains covers its body. It then helps to transfer the pollen grain from the anther to the stigma of the same different flower.**



**Q31 (a) Part Y.**

**(b) Dark cupboard. The most number of seeds germinated in the dark cupboard which shows the dark cupboard is the most suitable place for seeds to germinate.**

**(c) The seedlings have to photosynthesis and make food for themselves using light since there is no more seed leaf. There is no light in the dark cupboard so they will die from starvation.**

**Q32 (a) (i) Food Producer: R**

**(ii) Decomposer: U**

**(b) There was no air in the sealed can and decomposers require air to reproduce and survive.**

**(c) Toast one slice of bread and leave the other slice of bread in its original way. Leave both of them in the open and after a few days, observe if any slice have turned bad.**

**Q33 (a) Bird and squirrel population. The bee pollinates the flowers which result in fertilization and fruits are produced from the ovary. However, without pollination, fruits cannot be produced so birds and squirrels' only food source is not available and their population will eventually be wipe out.**

**(b) They need not compete for the same type of food.**

**Q34 (a) (i) Benefit 1: Animal W rests during the hot day in deep holes dug out in the sand so that it can avoid the heat.**

**(ii) Benefit 2: Animal W stays in a herd to protect itself from predators.**

**(b) Animal W has a white coat in summer since the weather is very hot and white does not absorb so much heat from its surroundings. Animal W has a brownish-grey coat in winter which is a darker colour since the weather is cooler, to reduce heat loss from its body to the surroundings and absorb as much heat from the surroundings to its body to feel warmer.**

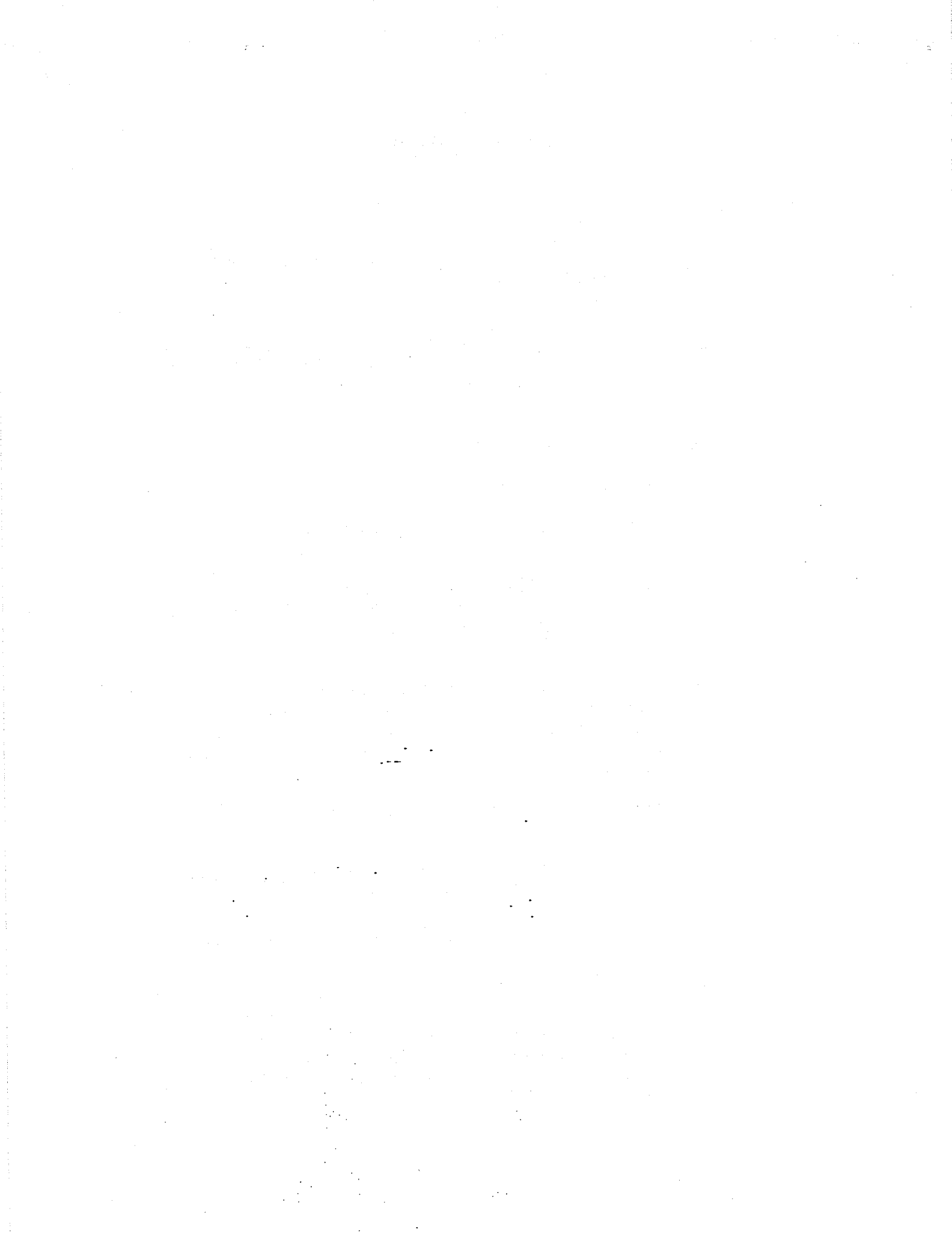

(c) It feeds on plants which contains moisture so it does not need to drink often.

Q35 (a) Plank C. The distance  $d$  is smallest so it is the least flexible.

(b) Plank C  
Plank B

Q36 (a)

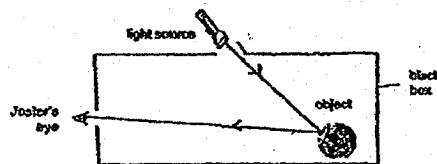

(b) Light travels in a straight line and can be reflected by objects.

Q37 (a) Water from the salt water.

(b) Water from the salt water gains heat and evaporates to form water vapour. Water vapour loses heat to the cooler surface of the glass cover and condensed into water vapour.

(c) As the amount of sunlight increases, the amount of water collected increases.

Q38 (a) Cloth A. Cloth A has a bigger exposed surface area than cloth B, so the droplets of water on A will gain heat faster from the sun and evaporate to become water vapour faster than on B, so A will dry faster than B.

(b) Place a fan near cloth B or place cloth B at a place with a higher temperature.

(c) Repeat the experiment a few times and take the average results.





Q39 (a)

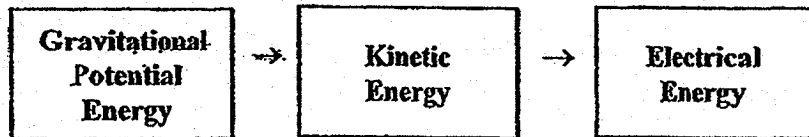

(b) **Advantage:** *More electrical energy will be produced.*

**Reason:** *The water in the tank will have more gravitational potential energy at a higher level, converting to more kinetic energy of the running water and into the turbine, and finally converting to more electrical energy produced in the generator.*

Q40 (a)

*To find out how the present or amount of thick strips of white paint affects the average time taken by each car to reach the bottom of the ramp.*

(b) *To confirm that the average time taken by each car to reach the bottom of the ramp is only due to the presence (A & B) or amount of (B & C) thick strips of white paint.*

(c) *Frictional Force.*

(d) *Surface C. The toy car took the longest time to reach the bottom of surface C since there was the most friction between surface C and the wheels of the ramp. The most friction will prevent drivers from skidding on the roads, so the road will be safer for the drivers.*

