

**RIVER VALLEY PRIMARY SCHOOL**  
**SEMESTRAL ASSESSMENT 1**  
**2019**  
**MATHEMATICS**  
**PRIMARY SIX**

Name : \_\_\_\_\_ (       )

Class : Primary 6 ( \_\_\_\_\_ )

Date : 17 May 2019

Duration : 60 min (Total time for Booklets A and B)

**PAPER 1**

**(BOOKLET A)**

**INSTRUCTIONSTO CANDIDATES**

1. Write your Name, Register No. and Class in the space above.
2. Do not turn over this page until you are told to do so.
3. Follow all instructions carefully.
4. Answer all questions.
5. Shade your answers on the Optical Answer Sheet (OAS) provided.
6. You are **not** allowed to use a calculator.

Questions 1 to 10 carry 1 mark each. Questions 11 to 15 carry 2 marks each. For each question, four options are given. One of them is the correct answer. Make your choice (1, 2, 3 or 4). Shade the correct oval (1, 2, 3 or 4) on the Optical Answer Sheet. (20 marks)

1. What does the digit 5 in 4.153 stand for?

- (1) 5 ones
- (2) 5 tenths
- (3) 5 hundredths
- (4) 5 thousandths

2. Machine A can pack 1000 boxes in an hour. Machine B can pack 800 similar boxes in an hour. At these rates, how many more boxes can Machine A pack than Machine B in 6 hours?

- (1) 10800
- (2) 6000
- (3) 4800
- (4) 1200

3.  $40 + \frac{4}{100} + \frac{4}{1000} =$

- (1) 40.044
- (2) 40.404
- (3) 40.440
- (4) 44.040

4. Which of the following is not a net of this figure?

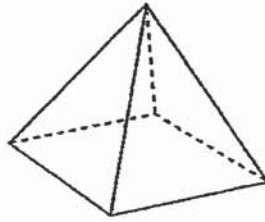

(1)

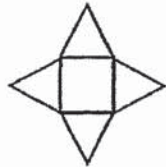

(2)

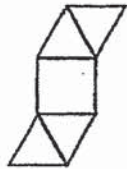

(3)

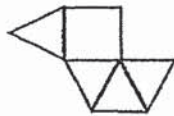

(4)

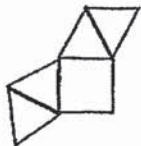

5. 40% of a number is 240. What is the number?

- (1) 96  
(2) 144  
(3) 600  
(4) 960

6. What is the area of the shaded triangle ABC below?

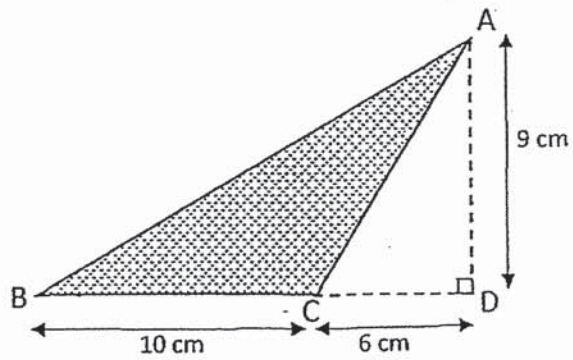

- (1) 27 cm<sup>2</sup>  
(2) 45 cm<sup>2</sup>  
(3) 72 cm<sup>2</sup>  
(4) 90 cm<sup>2</sup>
7. In the scale below, what is the value of X?

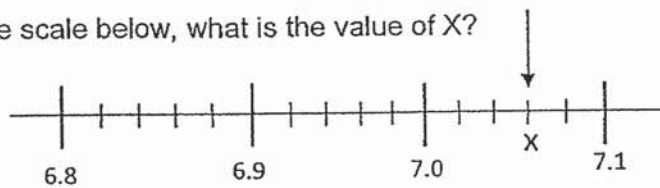

- (1) 7.075  
(2) 7.06  
(3) 7.6  
(4) 7.3

8. Rashid took 50 min to walk from his house to the park and back. If his average speed for the whole journey was 30 m/min, what was the distance between his house and the park?

- (1)  $1\frac{2}{3}$  m
- (2)  $\frac{3}{5}$  m
- (3) 750 m
- (4) 1500 m

9. Siti has  $\frac{4}{5}$  m of cloth. She used  $\frac{1}{4}$  of it. How much cloth did she have left?

- (1)  $\frac{1}{5}$  m
- (2)  $\frac{3}{5}$  m
- (3)  $\frac{9}{20}$  m
- (4)  $\frac{11}{20}$  m

10. Which of the following is likely to be the height of the school's flagpole?

- (1) 45 cm
- (2) 450 cm
- (3) 45 m
- (4) 450 m

11. Mrs Sim had \$20. After buying 4 identical files, she had \$m left.  
Express the cost of 1 file in terms of m.

(1)  $\$ \left( \frac{20 - m}{4} \right)$

(2)  $\$ \left( 20 - \frac{m}{4} \right)$

(3)  $\$ ( 20 - 4m )$

(4)  $\$ \left( \frac{20m}{4} \right)$

12. The pie chart shows the favourite stalls of the pupils in Primary 6. Each pupil could only choose one stall.

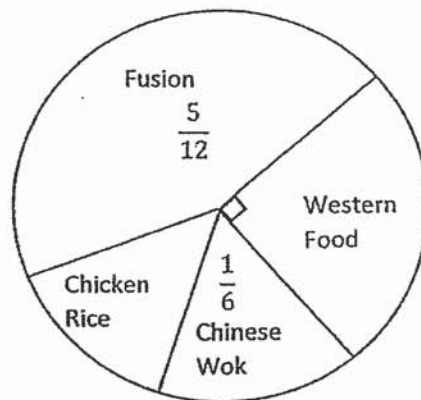

48 more pupils chose the Fusion stall than the Western Food stall as their favourite stall. How many Primary 6 pupils were there altogether?

- (1) 72  
(2) 120  
(3) 192  
(4) 288

13. A shop was selling mobile phones at a discount of 15%. As a member of the shop, Mr Lee received an additional 10% discount on top of the discounted price. In the end, he paid \$765 for a mobile phone. What was the total discount that Mr Lee received?
- (1) \$85
  - (2) \$150
  - (3) \$235
  - (4) \$1000
14. Alice and Candice have a total of \$128. Candice and Belinda have a total of \$78. Alice has three times as much money as Belinda. What is the average amount of money the three girls have?
- (1) \$51
  - (2) \$75
  - (3) \$153
  - (4) \$206
15. A rope was first cut into 2 pieces in the ratio of 3 : 2. The longer piece was then cut into 2 pieces in the ratio 3 : 1. Among the three pieces, the longest piece was 18 cm. What was the original length of the rope before it was first cut?
- (1) 24 cm
  - (2) 30 cm
  - (3) 36 cm
  - (4) 40 cm

**RIVER VALLEY PRIMARY SCHOOL**  
**SEMESTRAL ASSESSMENT 1**  
**2019**  
**MATHEMATICS**  
**PRIMARY SIX**

Name : \_\_\_\_\_ (       )

Class : Primary 6 ( \_\_\_\_\_ )

Date : 17 May 2019

Duration : 60 min (Total time for Booklets A and B)

**PAPER 1**  
**(BOOKLET B)**

**INSTRUCTIONSTO CANDIDATES**

1. Write your Name, Register No. and Class in the space above.
2. Do not turn over this page until you are told to do so.
3. Follow all instructions carefully.
4. Answer all questions.
5. You are **not** allowed to use a calculator.

**SUMMARY OF MARKS :**

			Questions	Marks Awarded	Maximum Marks
Paper 1	Booklet A	MCQ	1 – 15		20
	Booklet B	SAQ	16 – 30		25
Paper 2		SAQ	1 – 5		10
		LAQ	6 - 17		45
	Total				100

Parent's Signature :



Questions 16 to 20 carry 1 mark each. Write your answers in the spaces provided. For questions which require units, give your answers in the units stated. (5 marks)

Do not write in this space

16. Write two hundred and five thousand and eighty-four in numerals.

Ans: \_\_\_\_\_

17. 64 099 people watched a match at the stadium. Round off the number of people to the nearest hundred.

Ans: \_\_\_\_\_

18. Measure and write down the size of  $\angle f$ .

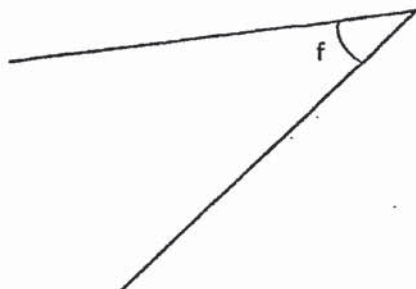

Ans: \_\_\_\_\_

19. Find the value of  $1.08 \times 40$

Do not write  
in this space

Ans: \_\_\_\_\_

20 Express  $\frac{7}{9}$  as a percentage. Give your answer to the nearest  
1 decimal place.

Ans: \_\_\_\_\_%

Questions 21 to 30 carry 2 marks each. Show your working clearly and write your answers in the spaces provided. For questions which require units, give your answers in the units stated. (20 marks)

Do not write in this space

21. Shade two more boxes in the square grid below so that Line XY is the line of symmetry.

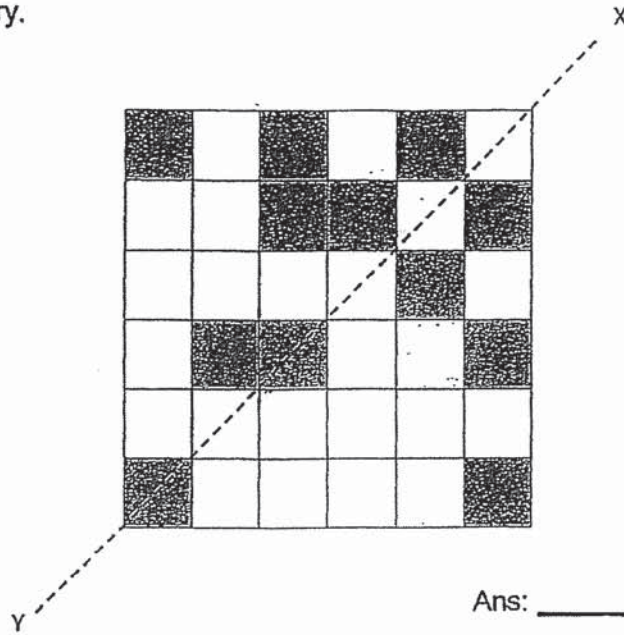

Ans: \_\_\_\_\_

22. The volume of a cube is  $64 \text{ cm}^3$ . Find the total area of all the faces of the cube.

Ans \_\_\_\_\_  $\text{cm}^2$

23. Two whole numbers add up to 623. One of them is a 2-digit number and the other is a 3-digit number. What is the largest possible difference between the two numbers?

Do not write  
in this space

Ans: \_\_\_\_\_

24. The table shows how much a shop charges for dry-washing services.

First 5 jackets	\$50
Each additional jacket	\$8

Mrs Wong paid \$98 to dry wash some jackets. How many jackets did she send to dry wash?

Ans: \_\_\_\_\_

25. Bee Ling had 1080 red, blue and yellow beads. She had 20 more blue beads than red beads. She had 3 times as many yellow beads as blue beads. How many yellow beads did Bee Ling have?

Ans: \_\_\_\_\_

26. A box contains marbles of three different colours.  $\frac{2}{5}$  of the marbles are blue. The ratio of the number of red marbles to that of the green marbles is 3 : 4. There are 16 more blue than green marbles. How many red marbles are there?

Do not write  
in this space

Ans: \_\_\_\_\_

27. The grid below shows a straight line AB. Draw another straight line that is parallel to Line AB and passes through Dot C.

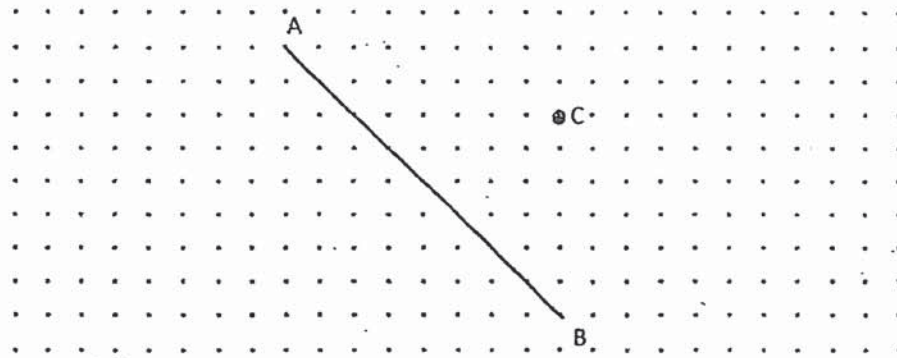

28. Draw the top view of the following solid in the square grid provided.

Do not write  
in this space

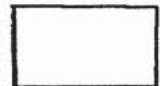
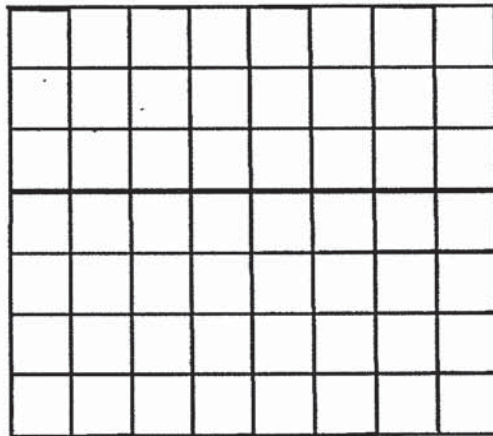
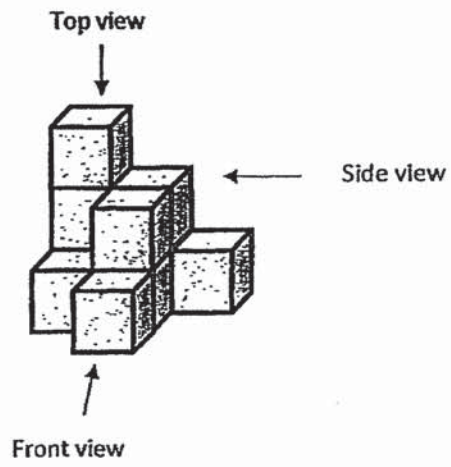

29. In the figure below, PQRS is a parallelogram. PTSU is a straight line.  $\angle PQT = 47^\circ$  and  $\angle RSU = 68^\circ$ . Find  $\angle RQT$ .

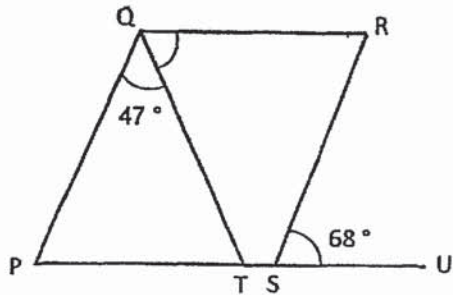

Ans: \_\_\_\_\_ °

30. Last year, Weiting saved an average of \$80 per month from January to November. She **did not** save any money in December.

Each statement below is either true, false or not possible to tell from the information given. For each statement, put a (✓) in the correct column.

Statement	True	False	Not possible to tell
a) Weiting saved a total of \$950 last year.			
b) The average amount of money that Weiting saved from January to November was higher than the average amount of money she saved from January to December.			

- End of Booklet B -

**RIVER VALLEY PRIMARY SCHOOL**  
**SEMESTRAL ASSESSMENT 1**  
**2019**  
**MATHEMATICS**  
**PRIMARY SIX**

Name : \_\_\_\_\_ (       )

Class : Primary 6 ( \_\_\_\_\_ )

Date : 17 May 2019

Duration : 1 h 30 min

**PAPER 2**

**INSTRUCTIONS TO CANDIDATES**

1. Write your Name, Register No. and Class in the space above.
2. Do not turn over this page until you are told to do so.
3. Follow all instructions carefully.
4. Answer all questions.
5. You are allowed to use a calculator.



Questions 1 to 5 carry 2 marks each. Show your working clearly and write your answers in the spaces provided. For questions which require units, give your answers in the units stated. (10 marks)

1. Asree bought the bag shown in the advertisement below. She still had to pay 7% GST after the discount. How much did she pay for the bag?

Do not write in this space

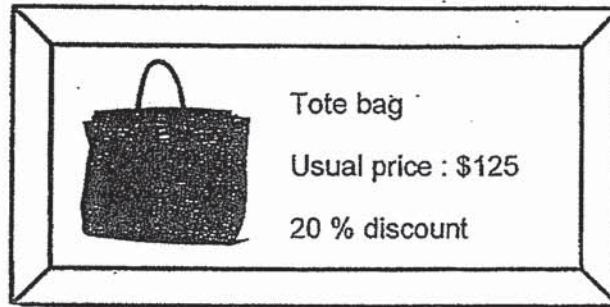

Ans : \$ \_\_\_\_\_

2. Mr Ding had 84 more haversacks than Mr En at first. After Mr En sold 25 haversacks to Mr Ding, Mr Ding had 3 times as many haversacks as Mr En. How many haversacks did Mr En have at first?

Ans : \_\_\_\_\_

3. Chong and Dan had some money. Chong spent  $\frac{1}{3}$  of his money on a meal and Dan spent  $\frac{1}{4}$  of his money on a file. Both boys had an equal amount of money left. If Chong had \$15 more than Dan at first, how much money did the 2 boys have altogether at first?

Do not write  
in this space

Ans : \$ \_\_\_\_\_

4. What is the area of the shaded figure drawn on the 1-cm square grid below?

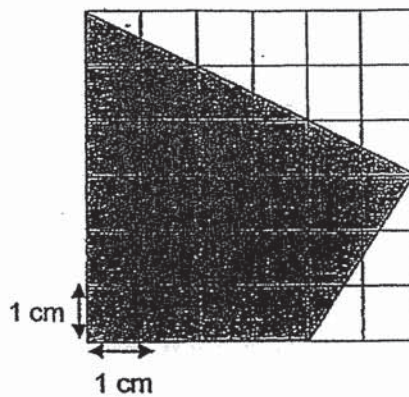

Ans : \_\_\_\_\_ cm<sup>2</sup>

5. The bar graph shows the number of children in the families living in a block of flats.  $\frac{2}{5}$  of the families in the block of flats have 2 children. Draw the bar that shows the number of families with 2 children.

Do not write in this space

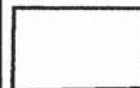
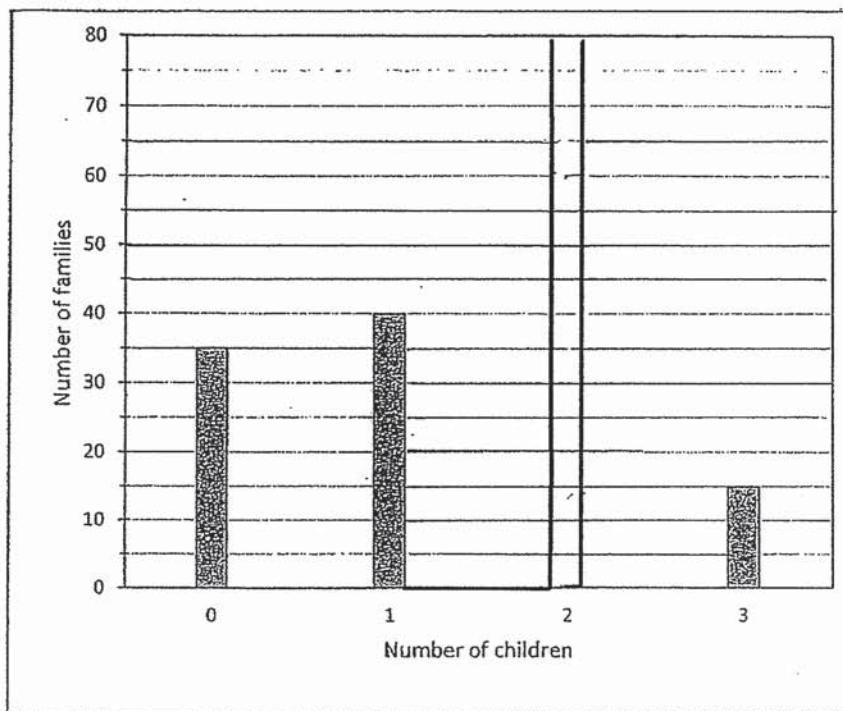

For questions 6 to 17, show your working clearly and write your answers in the spaces provided. The number of marks available is shown in brackets ( ) at the end of each question or part-question. (45 marks)

6. A shop offered 120 iPads at a discount during a 5-day sale. The line graph below shows the number of iPads left **unsold** at the end of each day.

Do not write in this space

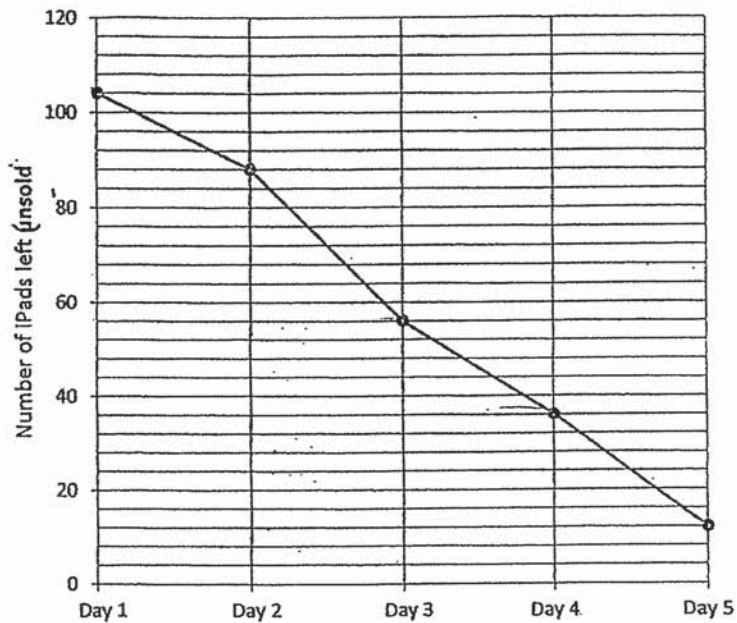

- (a) On which day was the most number of iPads sold?
- (b) What percentage of the 120 iPads were sold in the first 2 days of the sale? Leave your answer correct to 1 decimal place.

Ans: (a) \_\_\_\_\_ (1)  
 (b) \_\_\_\_\_ (2)

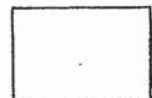

7. Mrs Tan paid  $\$m$  for 3 pies and 2 cakes. Each pie cost  $\$4$ .

Do not write  
in this space

(a) How much did each cake cost? Leave your answer in terms of  $m$ .

(b) How much did each cake cost when  $m = 120$ ?

Ans : (a) \_\_\_\_\_ (1)

(b) \_\_\_\_\_ (2)

8. In a function room, chairs were arranged in rows such that there were exactly 11 chairs in each row. After lunch, Pavan brought 6 more chairs into the room and rearranged all the chairs into exactly 8 chairs in each row. As a result there were 12 more rows than before. How many chairs were there in the function room before lunch?

Ans : \_\_\_\_\_ (3)

9. The figure below is made up of a rectangle and a circle. Q is the centre of the circle. The radius of the circle is 14 cm. QRST is a rectangle and  $RS = 34$  cm. Use the calculator  $\pi$  to find the perimeter of the shaded part of the rectangle. Leave your answer correct to 2 decimal places.

Do not write  
in this space

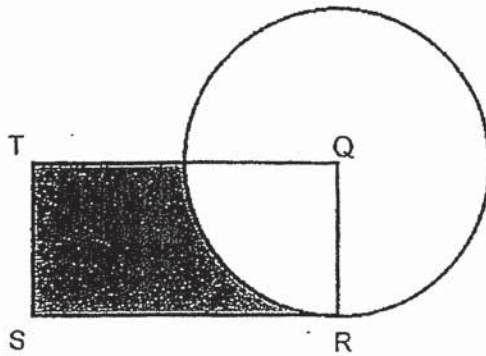

Ans: \_\_\_\_\_(3)

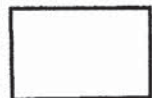

10. A van left Town A for Town B travelling at an average speed of 92 km/h for the first 30 minutes of the journey. Then the van drove another 32 km at an average speed of 80 km/h before reaching Town B. What was the average speed of the van for the whole journey?

Do not write  
in this space

Ans : \_\_\_\_\_ (3)

11. Cheryl, Dewi and Eli spent some money. The ratio of the amount of money Cheryl spent to the total amount of money Dewi and Eli spent was 3 : 4 . Dewi spent  $\frac{2}{3}$  as much money as the total amount of money spent by Cheryl and Eli. Cheryl spent \$369 more than Eli. How much money did Dewi spend?

Ans : \_\_\_\_\_ (3)

12. Kris bought an equal number of apples, pears and lemons to make some pies for a charity sale. The prices of the fruits are shown below. The total amount she paid for the apples and lemons was \$66 more than the amount she paid for the pears. How much money did Kris pay altogether for the fruits she bought?

Do not write  
in this space



Apples  
5 for \$4



Pears  
3 for \$2



Lemons  
10 for \$6

Ans : \_\_\_\_\_(4)

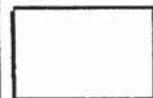



13 In the figure below, ABCD is a rhombus and  $DE \parallel CF$ .

$\angle ABG = 86^\circ$  and  $\angle AHE = 108^\circ$ .

(a) Find  $\angle BDE$

(b) Find  $\angle DCF$

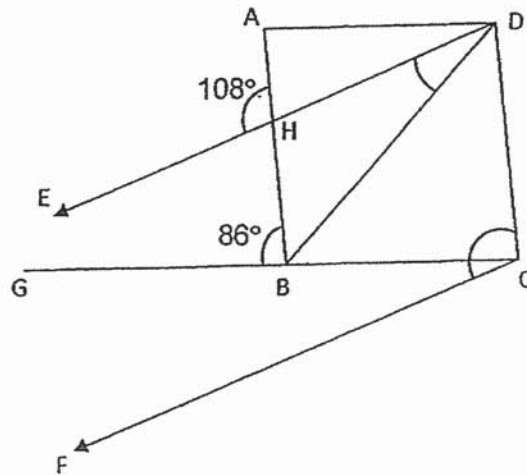

Do not write  
in this space

Ans : (a) \_\_\_\_\_ (2)

(b) \_\_\_\_\_ (2)

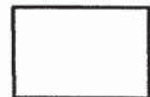

14. The figure below shows a semicircle with centre  $O$  and three triangles,  $ABC$ ,  $ACO$  and  $AEO$ .  $AB$  is parallel to  $ED$ ,  $\angle ACB = 136^\circ$  and  $\angle BAC = 18^\circ$ .

Do not write  
in this space

(a) Find  $\angle COD$ .

(b) Find  $\angle AEO$ .

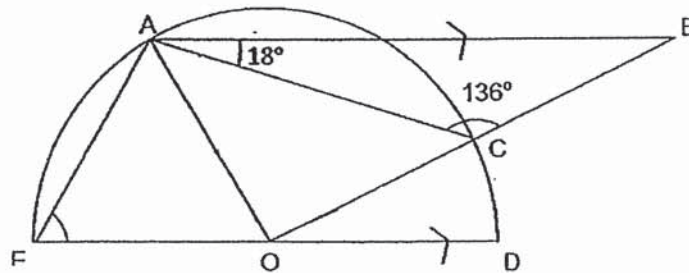

Ans: (a) \_\_\_\_\_ (2)

(b) \_\_\_\_\_ (2)

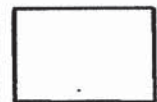

15. The figure below is made up of quadrants and semicircles.

(a) Find the perimeter of the shaded figure.

(b) Find the area of the shaded figure.

(Take  $\pi = \frac{22}{7}$ )

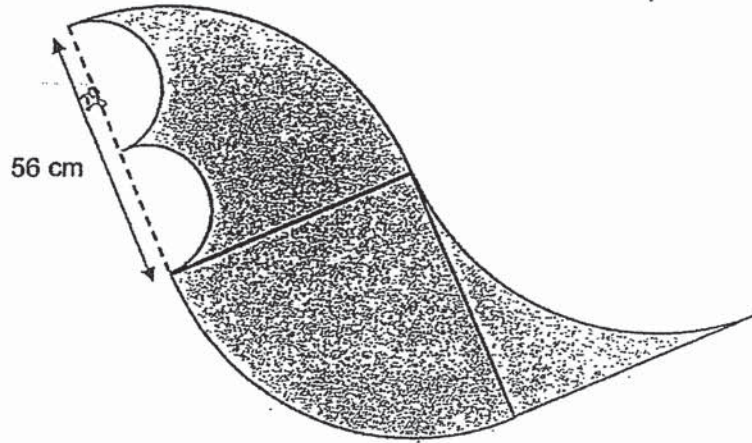

Do not write  
in this space

Ans : (a) \_\_\_\_\_ (2)

(b) \_\_\_\_\_ (3)

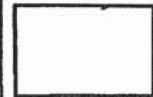

16. June and Kelvin have a collection of game cards. If June gives Kelvin half of her game cards, Kelvin will have 72 more game cards than June. If June gives Kelvin  $\frac{1}{6}$  of her game cards, she will have 16 fewer game cards than Kelvin. How many game cards do they have in all?

Do not write  
in this space

Ans : \_\_\_\_\_ (5)

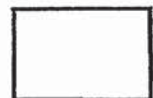

17. Grandma has 2 rectangular tanks, Tank X and Tank Y. Tank X is an empty container with a square base of sides 30 cm. Tank Y measures 20 cm by 30 cm by 100 cm. Tank Y was  $\frac{4}{5}$  filled with water at first.

Do not write  
in this space

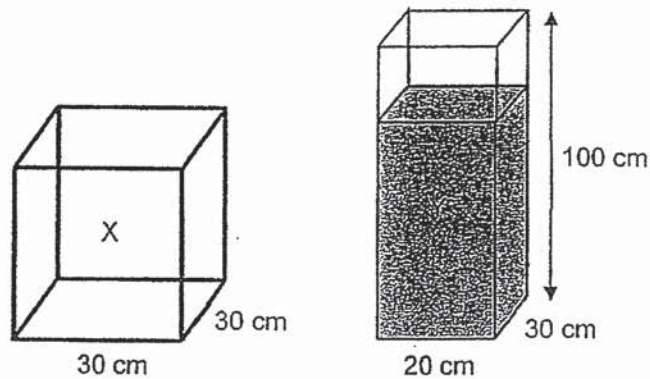

Grandma then poured some water from Tank Y into Tank X until the height of the water in Tank X became 2 times the height of the water in Tank Y.

- (a) How much water was in Tank Y at first?  
(b) What was the height of the water in Tank X in the end?

Ans: (a) \_\_\_\_\_ (1)

(b) \_\_\_\_\_ (4)

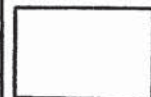

- End of Paper 2 -

www.TestPapersFree.com

**SCHOOL : RIVER VALLEY PRIMARY SCHOOL**  
**LEVEL : PRIMARY 6**  
**SUBJECT : MATH**  
**TERM : 2019 SA1**

**PAPER 1 BOOKLET A**

Q 1	Q2	Q3	Q4	Q5	Q6	Q7	Q8	Q9	Q10
3	4	1	3	3	2	2	3	2	2

Q 11	Q12	Q13	Q14	Q15
1	4	3	1	4

**PAPER 1 BOOKLET B**

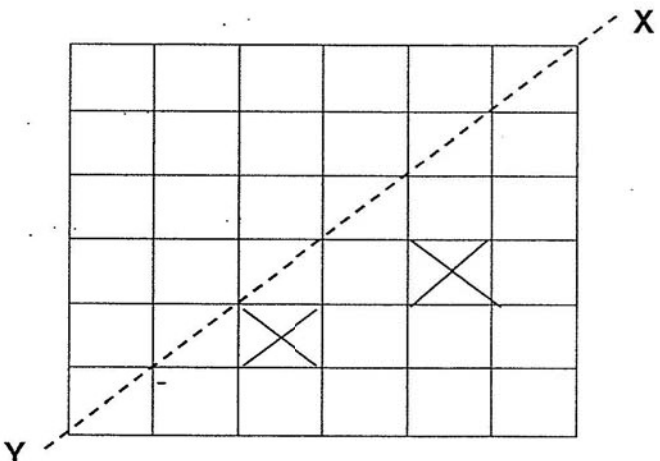
Q16)	205084
Q17)	64100
Q18)	36°
Q19)	43.2
Q20)	77.8%
Q21)	
Q22)	$4 \times 4 \times 6 = 96\text{cm}^2$
Q23)	603

Q24)	11
Q25)	660
Q26)	72
Q27)	
Q28)	
Q29)	65°
Q30)	a)False b)True

**PAPER 2**

Q1)	$80\% \times 125 = 100$ $107\% \times 100 = \$107$
Q2)	$3U - 1U = 2U$ $2U \rightarrow 25 + 84 + 25 = 134$ $1U \rightarrow 134 \div 2 = 67$ $67 + 25 = 92$
Q3)	$9U - 8U = 1U$ $1U \rightarrow 15$ $17U \rightarrow 17 \times 15 = \$255$
Q4)	$6 \times 6 = 36$ $\frac{1}{2} \times 6 \times 3 = 9$

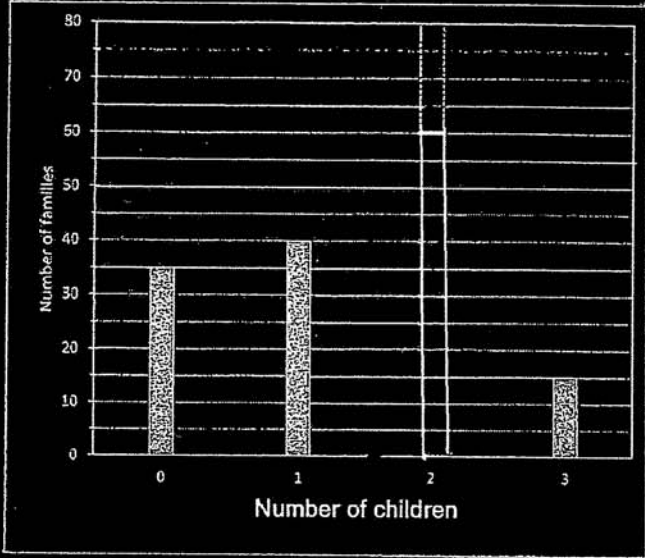

	$\frac{1}{2} \times 3 \times 2 = 3$ $36 - 9 - 3 = 24 \text{ cm}^2$										
Q5)	$\frac{5}{5} - \frac{2}{5} = \frac{3}{5}$ $\frac{3}{5} \rightarrow 35 + 40 + 15 = 90$ $\frac{2}{5} \rightarrow \frac{90}{3} \times 2 = 60$  <table border="1" data-bbox="347 546 995 1102"> <caption>Data for Bar Chart</caption> <thead> <tr> <th>Number of children</th> <th>Number of families</th> </tr> </thead> <tbody> <tr> <td>0</td> <td>35</td> </tr> <tr> <td>1</td> <td>40</td> </tr> <tr> <td>2</td> <td>0</td> </tr> <tr> <td>3</td> <td>15</td> </tr> </tbody> </table>	Number of children	Number of families	0	35	1	40	2	0	3	15
Number of children	Number of families										
0	35										
1	40										
2	0										
3	15										
Q6)	<p>a) Day 3</p> <p>b) <math>120 - 104 = 16</math>  <math>104 - 88 = 16</math>  <math>16 + 16 = 32</math>  <math>\frac{32}{120} \times 100\% = 26.66 \approx 26.7\%</math></p>										
Q7)	<p>a) <math>4 \times 3 = 12</math>  <math>= \\$\left(\frac{m-12}{2}\right)</math></p> <p>b) <math>120 - 12 = 108</math>  <math>108 \div 2 = \\$54</math></p>										
Q8)	$12 \times 8 = 96$ $96 - 6 = 90$ $11 - 8 = 3$ $90 \div 3 = 30$ $11 \times 30 = 330$										
Q9)	$34 - 14 = 20$ $\pi \times 28 \times \frac{1}{4} = 7\pi$										

	$7\pi + 34 + 14 + 20 = 89.99cm$
Q10)	 <p> <math>92km/h \times \frac{1}{2} h = 46km</math>  <math>32km \div 80km/h = \frac{2}{5}h</math>  <math>46 + 32 = 78</math>  <math>78 \div (\frac{2}{5} + \frac{1}{2}) = 86.6km/h</math>  <math>= 86\frac{2}{3} km/h</math> </p>
Q11)	$15u - 6u = 9u$ $9u \rightarrow 369$ $14u \rightarrow \frac{369}{9} \times 14 = \$574$
Q12)	$72 + 60 + 54 = \$186$
Q13)	<p>a) <math>\angle AHE = \angle DHE = 10^\circ</math>  <math>\angle HBD = (180^\circ - 86^\circ) \div 2 = 47^\circ</math>  <math>\angle BDE = 180^\circ - 47^\circ - 108^\circ = 25^\circ</math></p> <p>b) <math>180^\circ - 86^\circ - 72^\circ = 22^\circ</math>  <math>86^\circ + 22^\circ = 108^\circ</math></p>
Q14)	<p>a) <math>\angle ABC = 180^\circ - 136^\circ - 18^\circ = 26^\circ</math>  <math>\angle ABC = \angle COD = 26^\circ</math></p> <p>b) <math>\angle ACO = 180^\circ - 136^\circ = 44^\circ</math>  <math>\angle AOC = 180^\circ - 44^\circ - 44^\circ = 92^\circ</math>  <math>\angle AOE = 180^\circ - 92^\circ - 26^\circ = 62^\circ</math>  <math>\angle AEO = (180^\circ - 62^\circ) \div 2 = 59^\circ</math></p>
Q15)	<p>a) <math>56 + 56 = 112</math>  <math>\frac{22}{7} \times 112 \times \frac{1}{4} = 88</math>  <math>\frac{22}{7} \times 28 \times \frac{1}{2} \times 2 = 88</math>  <math>(88 \times 3) + 88 = 352</math>  <math>352 + 56 = 408cm</math></p> <p>b) <math>\frac{22}{7} \times 56 \times 56 \times \frac{1}{2} = 4928</math></p>

	$\frac{22}{7} \times 14 \times 14 = 616$ $4928 - 616 = 4312$ $(56 \times 56) - \left(\frac{22}{7} \times 56 \times 56 \times \frac{1}{4}\right) = 672$ $4312 + 672 = 4984 \text{cm}^2$																
Q16)	<table style="width: 100%; border-collapse: collapse;"> <tr> <td style="text-align: center; width: 50%; border-bottom: 1px solid black;"> <math display="block">\begin{array}{r} \text{J} \quad : \quad \text{K} \\ 2\text{U} \quad 72 \\ -1\text{U} \quad +1\text{U} \\ \hline 1\text{U} \quad 1\text{U}+72 \end{array}</math> </td> <td style="text-align: center; width: 50%; border-bottom: 1px solid black;"> <math display="block">\begin{array}{r} \text{J} \quad : \quad \text{K} \\ 6\text{p} \quad 4\text{p}+16 \\ -1\text{p} \quad +1\text{p} \\ \hline 5\text{p} \quad 5\text{p}+16 \end{array}</math> </td> </tr> <tr> <td colspan="2"> <math display="block">4\text{p} + 16 = 72</math> <math display="block">4\text{p} = 72 - 16 = 56</math> <math display="block">1\text{p} = 56 \div 4 = 14</math> <math display="block">14 \times 10 = 140</math> <math display="block">140 + 16 = 156</math> </td> </tr> </table>	$\begin{array}{r} \text{J} \quad : \quad \text{K} \\ 2\text{U} \quad 72 \\ -1\text{U} \quad +1\text{U} \\ \hline 1\text{U} \quad 1\text{U}+72 \end{array}$	$\begin{array}{r} \text{J} \quad : \quad \text{K} \\ 6\text{p} \quad 4\text{p}+16 \\ -1\text{p} \quad +1\text{p} \\ \hline 5\text{p} \quad 5\text{p}+16 \end{array}$	$4\text{p} + 16 = 72$ $4\text{p} = 72 - 16 = 56$ $1\text{p} = 56 \div 4 = 14$ $14 \times 10 = 140$ $140 + 16 = 156$													
$\begin{array}{r} \text{J} \quad : \quad \text{K} \\ 2\text{U} \quad 72 \\ -1\text{U} \quad +1\text{U} \\ \hline 1\text{U} \quad 1\text{U}+72 \end{array}$	$\begin{array}{r} \text{J} \quad : \quad \text{K} \\ 6\text{p} \quad 4\text{p}+16 \\ -1\text{p} \quad +1\text{p} \\ \hline 5\text{p} \quad 5\text{p}+16 \end{array}$																
$4\text{p} + 16 = 72$ $4\text{p} = 72 - 16 = 56$ $1\text{p} = 56 \div 4 = 14$ $14 \times 10 = 140$ $140 + 16 = 156$																	
Q17)	<p>a) <math>\frac{4}{5} \times 20 \times 30 \times 100 = 48000 \text{ml}</math></p> <p>b)</p> <table style="width: 100%; border-collapse: collapse;"> <thead> <tr> <th style="width: 10%;"></th> <th style="width: 30%; text-align: center; border-bottom: 1px solid black;">Height</th> <th style="width: 30%; text-align: center; border-bottom: 1px solid black;">BA</th> <th style="width: 30%; text-align: center; border-bottom: 1px solid black;">volume</th> </tr> </thead> <tbody> <tr> <td>X</td> <td style="text-align: center;">2u</td> <td style="text-align: center;"><math>30 \times 30 = 900</math></td> <td style="text-align: center;"><math>1800\text{u}</math></td> </tr> <tr> <td>Y</td> <td style="text-align: center;">1u</td> <td style="text-align: center;"><math>20 \times 30 = 600</math></td> <td style="text-align: center;"><math>600\text{u}</math></td> </tr> <tr> <td></td> <td></td> <td></td> <td style="text-align: center; border-top: 1px solid black;"><math>2400\text{u}</math></td> </tr> </tbody> </table> <p style="margin-left: 40px;"> <math display="block">48000 \div 2400 = 20</math> <math display="block">20 \times 2 = 40\text{cm}</math> </p>		Height	BA	volume	X	2u	$30 \times 30 = 900$	$1800\text{u}$	Y	1u	$20 \times 30 = 600$	$600\text{u}$				$2400\text{u}$
	Height	BA	volume														
X	2u	$30 \times 30 = 900$	$1800\text{u}$														
Y	1u	$20 \times 30 = 600$	$600\text{u}$														
			$2400\text{u}$														