



CATHOLIC HIGH SCHOOL
PRELIMINARY EXAMINATION (2017)
PRIMARY SIX
SCIECCE
BOOKLET A

Name: _____ ()

Class: Primary 6 - _____

28 questions

56 marks

Total Time for Booklets A and B: 1 hour 45 minutes

INSTRUCTIONS TO CANDIDATES

Do not turn over this page until you are told to do so.

Follow all instructions carefully.

Answer all questions.

Shade your answers in the Optical Answer Sheet (OAS) provided.

This booklet consists of 19 printed pages, excluding the cover page.

Booklet A (28 × 2 marks)

For each question from 1 to 28, four options are given. One of them is the correct answer. Make your choice (1, 2, 3 or 4). Shade your answer on the Optical Answer Sheet. (56 marks)

- 1 Four pupils recorded their observations of an animal they saw at the Singapore Zoo.

- Ali Its body is covered with hair.
Betty It reproduces by laying eggs.
Chen Bin Its young resembles the adult.
Danny It moves by swimming and hopping.



Who gave the correct observations about the animal shown?

- (1) Ali and Danny only
(2) Ali and Chen Bin only
(3) Ali, Chen Bin and Danny only
(4) Betty, Chen Bin and Danny only

2 The diagram below shows parts of a human digestive system.

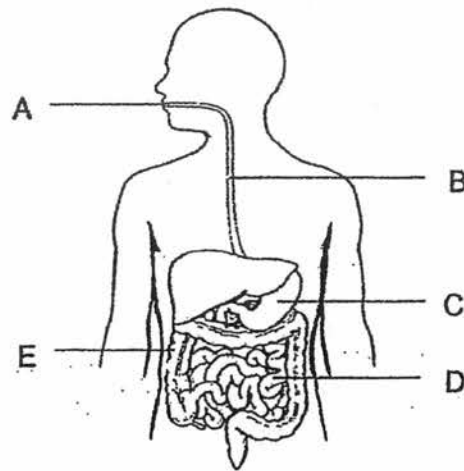

In which parts, A, B, C, D and E, are digestive juices found?

- (1) C and D only
- (2) A, C and D only
- (3) A, B, C and E only
- (4) A, B, D and E only

3 The diagrams below show the life cycles of 2 animals.

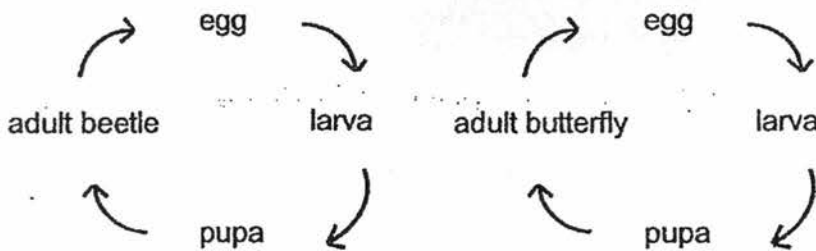

Which of the following statements about the life cycles of the animals are correct?

- A Both give birth to young alive.
- B Both their young do not resemble the adult.
- C The young will only become insects at the adult stage.
- D The pupa does not eat before reaching the adult stage.

- (1) A and C only
- (2) B and D only
- (3) A, C and D only
- (4) B, C and D only

- 4 Susan conducted an experiment to find out whether the presence of oxygen would affect the growth of seeds. She placed a few seeds in each of the four containers.

The table below shows the amount of water that Susan used to water the plants each day. It also shows which containers received oxygen and sunlight.

Container	Amount of water (ml)	Oxygen	Sunlight
A	5	Yes	No
B	10	No	Yes
C	5	No	Yes
D	10	Yes	Yes

Which two containers should she use if she wants to find out whether the presence of oxygen would affect the growth of seeds?

- (1) A and B only
- (2) A and C only
- (3) B and C only
- (4) B and D only

5 Study the diagram below.

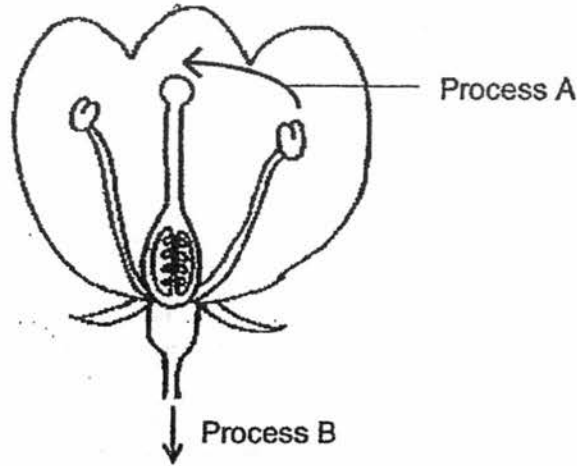

- The ovary develops into part X.
- The ovule develops into part Y.

Which of the following could processes A and B and parts X and Y be?

	A	B	X	Y
(1)	fertilisation	germination	fruit	seed
(2)	fertilisation	seed dispersal	seed	fruit
(3)	pollination	seed dispersal	seed	fruit
(4)	pollination	fertilisation	fruit	seed

- 6 John wanted to find out if the colour of the petals has an effect on the number of pollinators attracted to the flower. He had the following flowers.

Flower	Colour of petals	Characteristics
A	pink	anther within the flower
B	white	anther within the flower
C	yellow	small petals
D	white	sweet scent
E	purple	no scent
F	white	small petals

Which of the flowers should John use to conduct his investigation?

- (1) A and B only
 - (2) D and E only
 - (3) B, D and F only
 - (4) C, E and F only
- 7 The diagram below shows the male and female reproductive systems.

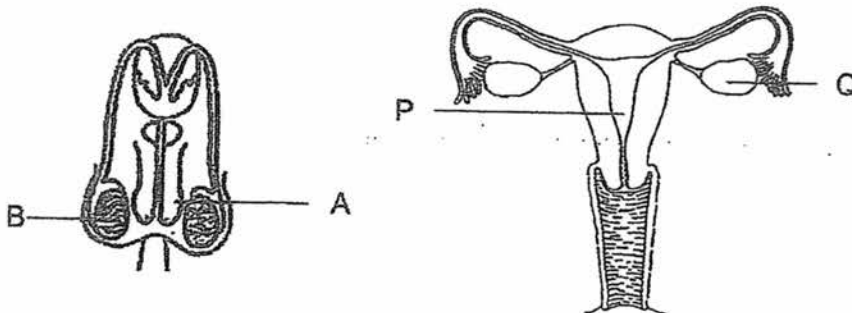

In which parts of the reproductive systems are the reproductive cells produced?

- (1) A and P only
- (2) A and Q only
- (3) B and P only
- (4) B and Q only

- 8 Some pupils were asked to find out if a plant takes in water through its roots. The following set-up was left in an open area for a few days.

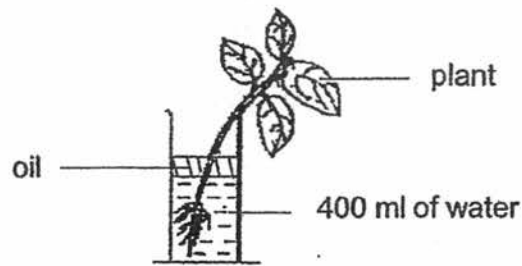

Which of the following should the pupils use as the control set-up for the experiment?

(1)

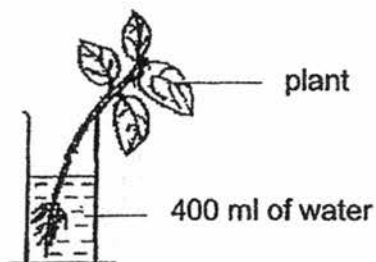

(2)

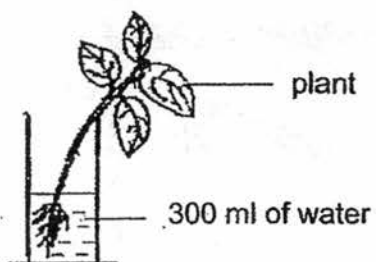

(3)

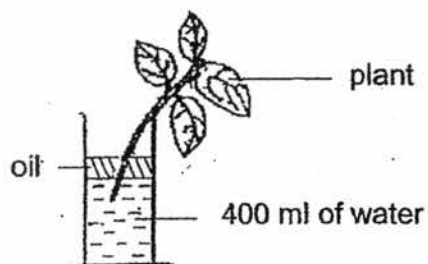

(4)

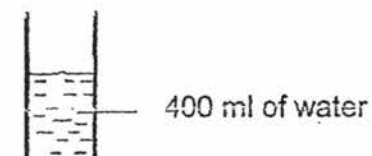

- 9 The diagram below shows how some substances are transported in the human body.

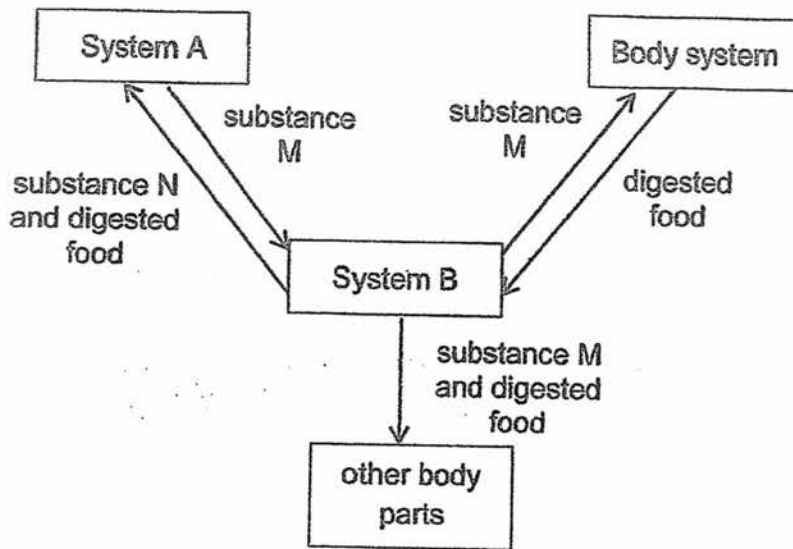

Which one of the following correctly identifies substances M and N, and Systems A and B?

	Substance M	Substance N	System A	System B
(1)	Carbon dioxide	Oxygen	Circulatory	Respiratory
(2)	Carbon dioxide	Oxygen	Respiratory	Digestive
(3)	Oxygen	Carbon dioxide	Digestive	Circulatory
(4)	Oxygen	Carbon dioxide	Respiratory	Circulatory

- 10 The diagram below shows a plant cell.

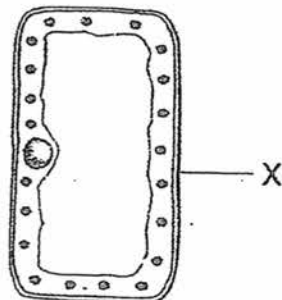

Which one of the following statements is correct about X?

- (1) It enables the cell to keep its shape.
- (2) It prevents substances from leaving the cell.
- (3) It prevents substances from entering the cell.
- (4) It helps trap light energy from the sun for the plant to make food.

11 The diagram below shows a certain process that takes place in green plants.

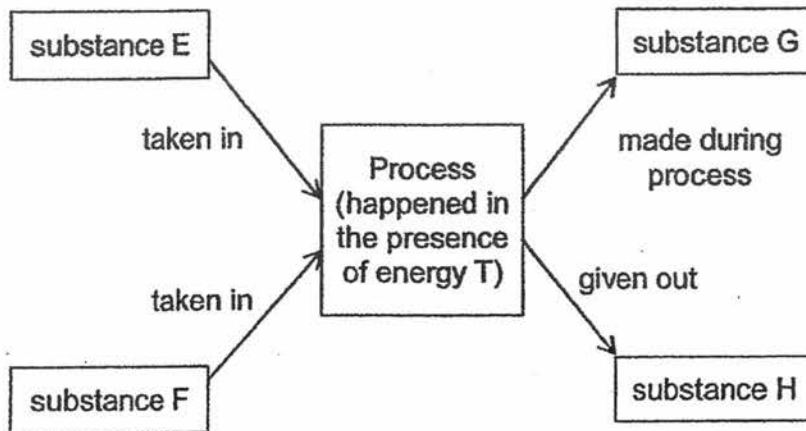

Which one of the following correctly identifies substances E, F, G and H?

	Substance				Energy T
	E	F	G	H	
(1)	Food	Water	Oxygen	Carbon dioxide	Light
(2)	Oxygen	Food	Carbon dioxide	Water	Heat
(3)	Carbon dioxide	Water	Food	Oxygen	Light
(4)	Carbon dioxide	Food	Oxygen	Water	Heat

12 The following relationships were observed among four living things J, K, L and M.

J feeds on L.
 M feeds on J.
 L gets its food from K.
 M feeds on L but does not feed on K.

Which one of the following identifies J, K, L and M correctly?

	Food producer	Prey	Prey and predator	Predator
(1)	K	M	J	L
(2)	M	J	L	K
(3)	K	L	J	M
(4)	M	K	L	J

13 The statements below are about the adaptations of some animals.

- A Wolf hunts in groups.
- B Grizzly bear eats a lot before hibernation.
- C Polar bear has thick fur coat to keep warm.
- D Fish uses gills to help them breathe in water.

Which of the following shows how the above adaptations can be classified?

	Behavioural adaptation	Structural adaptation
(1)	A, B	C, D
(2)	A, B, D	C
(3)	C	A, B, D
(4)	A, D	B, C

14 The statements below describe a field habitat and a tree habitat. Which one of them is not correct?

- (1) Air in the field habitat and tree habitat moves freely.
- (2) The field habitat is exposed to light while the tree habitat is shady.
- (3) Both the field and tree habitats get periods of brightness and darkness.
- (4) The tree habitat experiences greater temperature changes than the field habitat.

15 The food web shows the relationships between organisms V, W, X, Y and Z in a pond.

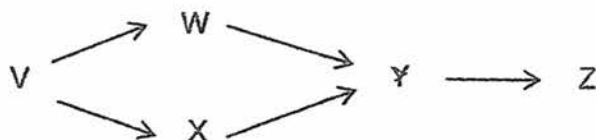

The whole population of Y died out due to water pollution.

Which one of the following correctly shows what would first happen to the populations of the other organisms after all of Y died?

	Organism	What would first happen to the population?
(1)	V	Increase
(2)	W	Increase
(3)	X	Decrease
(4)	Z	Increase

- 16 Wei Yi plotted the number of different organisms he saw in a school pond in the bar graph below.

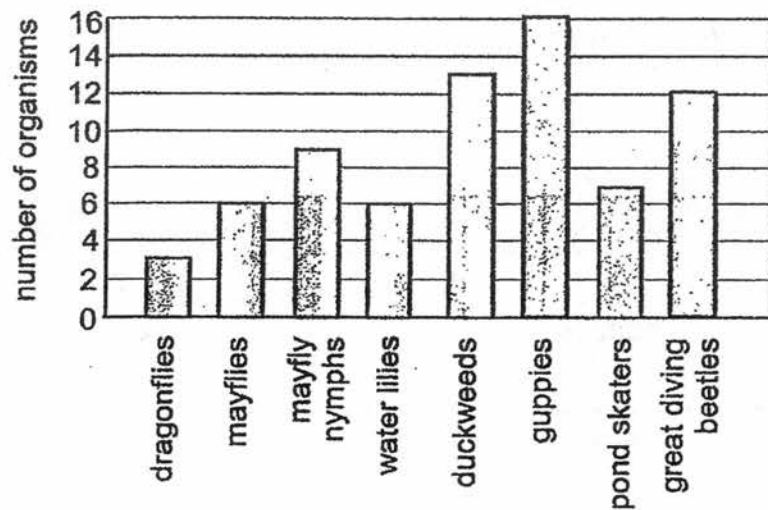

Which of the following statements is/are correct?

- A There are 5 insect populations.
- B There are less number of plants than animals.
- C There are 15 organisms in the mayfly population.
- D There are 7 communities living in the school pond.

- (1) A only
- (2) B and C only
- (3) A, B and C only
- (4) B, C and D only

- 17 Christine conducted an experiment to compare the absorbency of different types of materials. She placed 4 strips of materials, W, X, Y and Z, of identical size, into a basin of blue-coloured water for 10 minutes. Christine recorded her observations as shown in the diagram below.

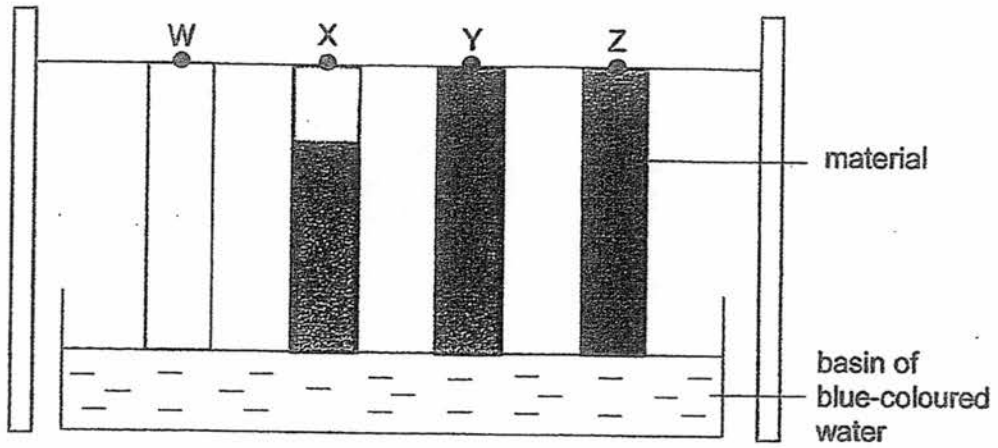

Based on the information above, which of the following shows the most suitable material to make a raincoat, a towel and a cup?

	Raincoat	Towel	Cup
(1)	Z	W	Y
(2)	W	X	Z
(3)	Y	X	Z
(4)	W	Z	W

- 18 Joe placed object A securely onto the plastic board and measured the length of the spring as shown in diagram X.

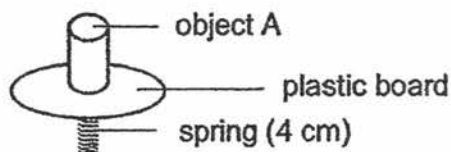

Diagram X

He wanted to find out if objects, A, B and C, would interact with the magnet hanging from the retort stand. He hung a magnet above object A and measured the length of the spring as shown in diagram Y. He repeated the experiment with objects B and C. Objects A, B and C are of the same mass.

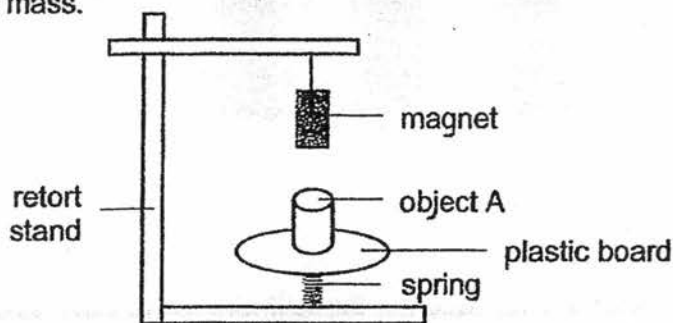

Diagram Y

The results of the experiments were recorded as below.

Object	Length of spring (cm)
A	3
B	4
C	6

Based on the results above, what could objects A, B and C be?

	Object A	Object B	Object C
(1)	magnet	copper bar	iron bar
(2)	magnet	iron bar	copper bar
(3)	iron bar	magnet	copper bar
(4)	iron bar	copper bar	magnet

- 19 A metal tank has a capacity of 1000 cm^3 . Which one of the following can Jane use to fill the tank completely?

- (1) 1200 cm^3 of oil
- (2) 1200 cm^3 of water
- (3) 1200 cm^3 of oxygen
- (4) 1200 cm^3 of rice grains

20 In the diagram shown below, an object is placed between the torch and the screen.

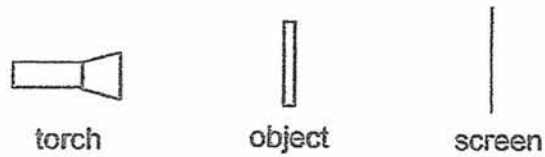

The object is made up of different materials as shown in the diagram below.

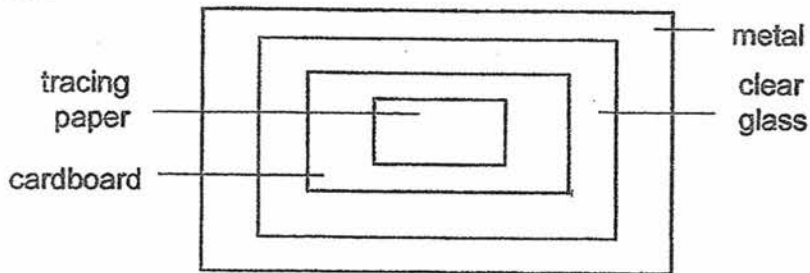

Legend:

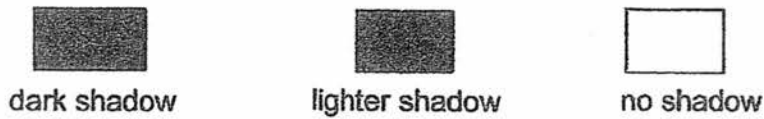

Which one of the following is most likely to be the shadow formed on the screen?

- (1)
- (2)
- (3)
- (4)

- 21 Sophia conducted an experiment to find out which liquid fuel, X or Y, produces more heat when burnt. The diagram below shows the set-ups for her experiment.

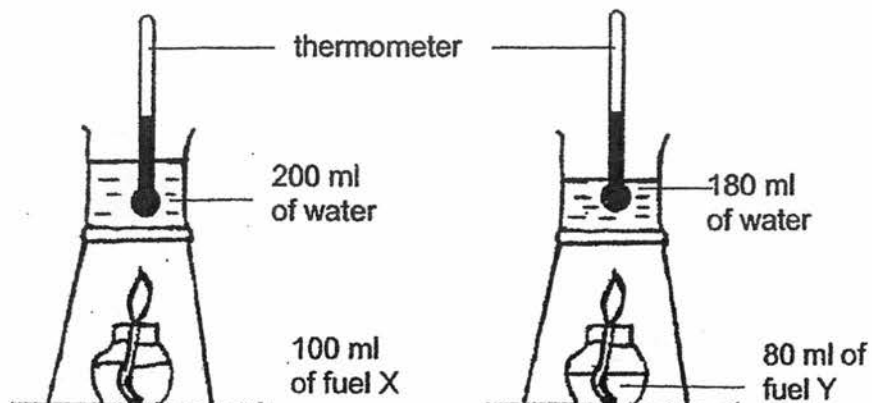

Sophia said that it was not a fair test. Which variables should Sophia keep the same to make it a fair test?

- A Volume of fuel
- B Volume of water
- C Type of liquid fuel
- D Initial temperature of the water

- (1) A and D only
- (2) B and C only
- (3) A, B and C only
- (4) A, B and D only

- 22 The table below shows the melting and boiling points of substances P, Q and R.

Substance	Melting point ($^{\circ}\text{C}$)	Boiling point ($^{\circ}\text{C}$)
P	42	78
Q	28	63
R	54	90

At which of the following temperatures will the three substances be in the same state?

- (1) 32°C
- (2) 60°C
- (3) 75°C
- (4) 80°C

- 23 Dan placed a beaker of crushed ice with a thermometer on a table as shown in the diagram below.

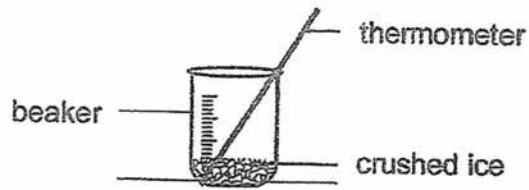

for 60 minutes

He left it to stand on the table. He observed the temperature of the crushed ice and recorded the readings in a graph. Which of the following graphs would he obtain?

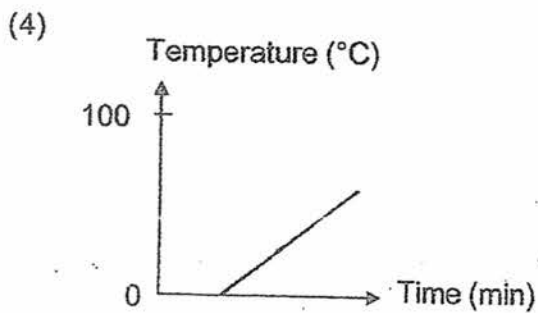
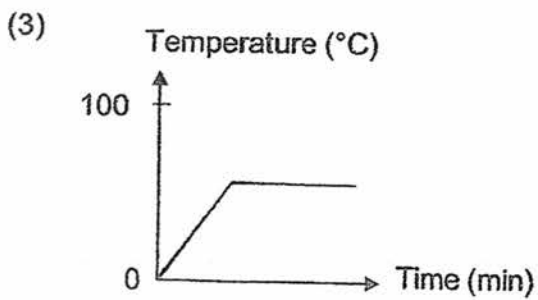
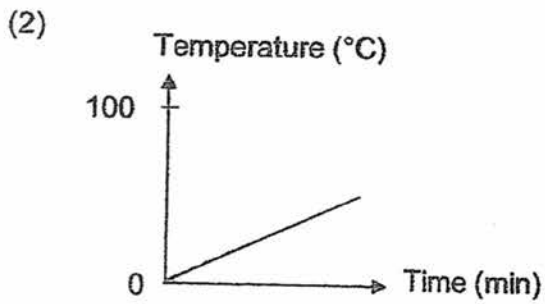
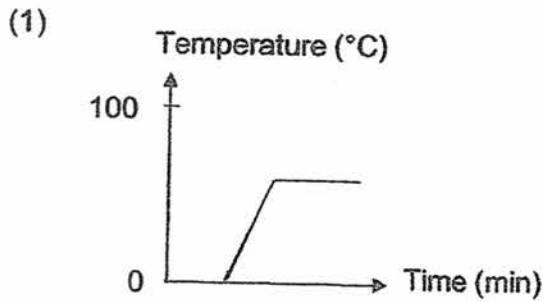

- 24 Bulbs D, E and F and switches G, H and J are connected in a circuit as shown. All bulbs in the circuit are working properly.

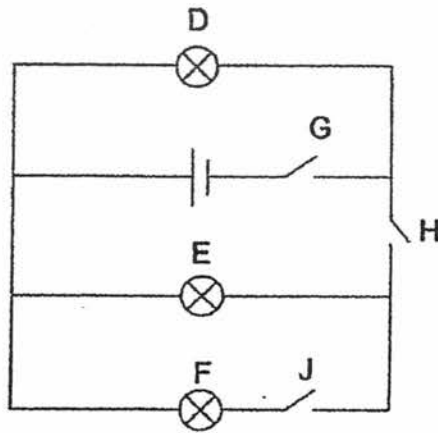

Which one of the following is correct?

	Does the bulb light up?			Switch		
	D	E	F	G	H	J
(1)	Yes	Yes	No	Closed	Closed	Open
(2)	No	Yes	No	Open	Closed	Open
(3)	Yes	No	Yes	Closed	Open	Closed
(4)	No	No	Yes	Open	Open	Closed

- 25 The diagram below shows how energy can be converted from one form to another form, through activities A, B, C and D.

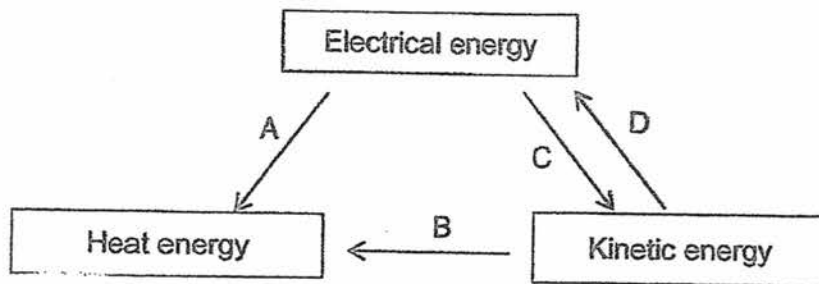

Which of the following could activities A, B, C and D be?

	A	B	C	D
(1)	Rubbing of palms	Using an oven	Using a ceiling fan	Turning a turbine
(2)	Using an oven	Rubbing of palms	Using a ceiling fan	Turning a turbine
(3)	Turning a turbine	Using a ceiling fan	Rubbing of palms	Using an oven
(4)	Using an oven	Rubbing of palms	Turning a turbine	Using a ceiling fan

- 26 The picture shows a group of children taking a roller coaster ride.

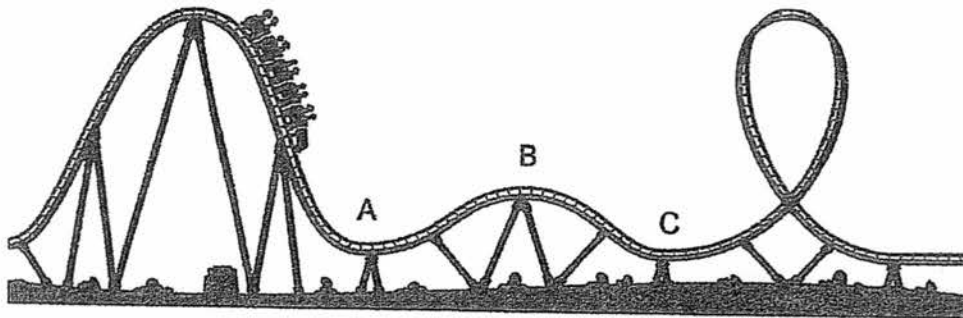

Which one of the following shows the changes in the kinetic energy and gravitational potential energy as the roller coaster travelled from A to C?

	Change in gravitational potential energy from A to B	Change in kinetic energy from B to C
(1)	Increase	Increase
(2)	Increase	Decrease
(3)	Decrease	Increase
(4)	Decrease	Decrease

27 Petrina conducted an experiment with two blocks of the same size but of masses 100 g and 200 g.

She then released the blocks from two different heights as shown in set-ups A, B, C and D.

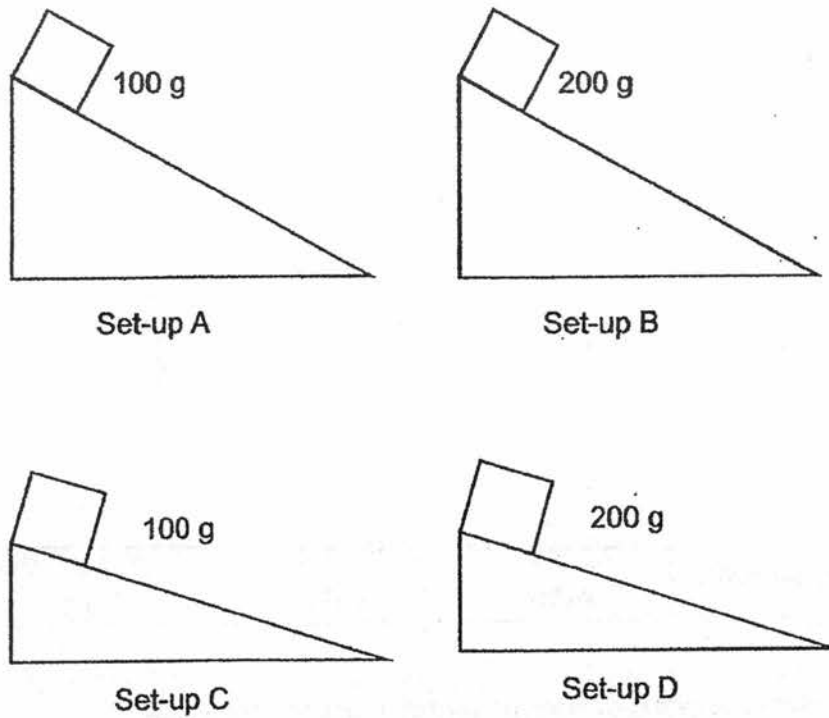

Petrina wanted to investigate how the gravitational potential energy of the block depends on its mass and the height from where it was released.

Which pairs of set-ups should she use in her investigation?

Gravitational potential energy depends on	
mass	height
(1) A and B	C and D
(2) B and D	A and C
(3) C and D	B and D
(4) A and C	A and B

- 28 The diagram below shows two similar loads X and Y being released from the same height on a parachute.

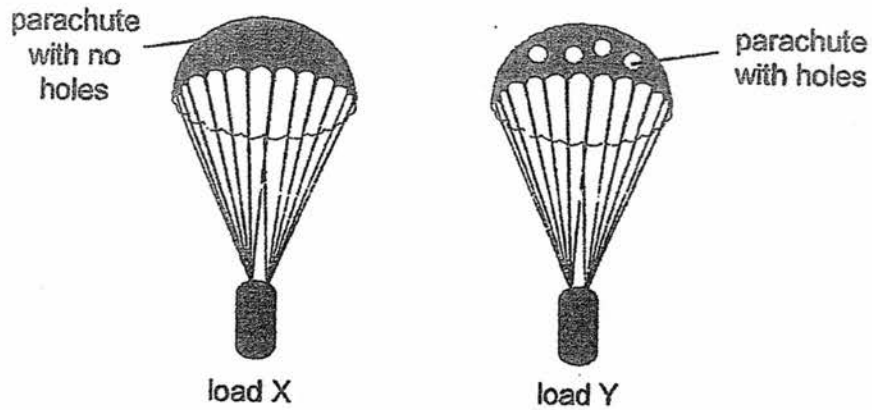

Which one of the following correctly explains why load Y falls faster than load X?

- (1) More gravitational force is acting on load Y.
- (2) More air is pushing down on the parachute of load Y.
- (3) Less force is acting upwards on the parachute of load Y.
- (4) There is more potential energy in load Y than load X before they were released.

End of Booklet A



CATHOLIC HIGH SCHOOL

PRELIMINARY EXAMINATION ONE (2017)

PRIMARY SIX

SCIENCE

BOOKLET B

Name: _____ ()

Class: Primary 6 - _____

Date: 9 May 2017

Parent's Signature: _____

Booklet A	56
Booklet B	44
Total	100

13 questions

44 marks

Total Time for Booklets A and B: 1 hour 45 minutes

INSTRUCTIONS TO CANDIDATES

Do not turn over this page until you are told to do so.

Follow all instructions carefully.

Answer all questions.

Write your answers in this booklet.

This booklet consists of 16 printed pages, excluding the cover page.

Booklet B (44 marks)

For questions 29 to 41, write your answers in this booklet.

The number of marks available is shown in brackets [] at the end of each question or part question. (44 marks)

29 Study the fruit below.

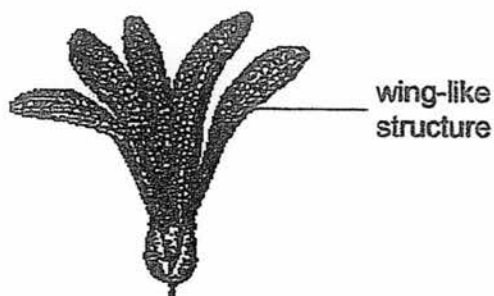

(a) State the dispersal method for the fruit above. [1]

(b) How does the structure help in its dispersal? [1]

(Go on to the next page)

SCORE	2
-------	---

- 30 The diagram below shows a plant placed in a beaker of red-coloured water. The outer ring of a section of the stem of the plant was removed.

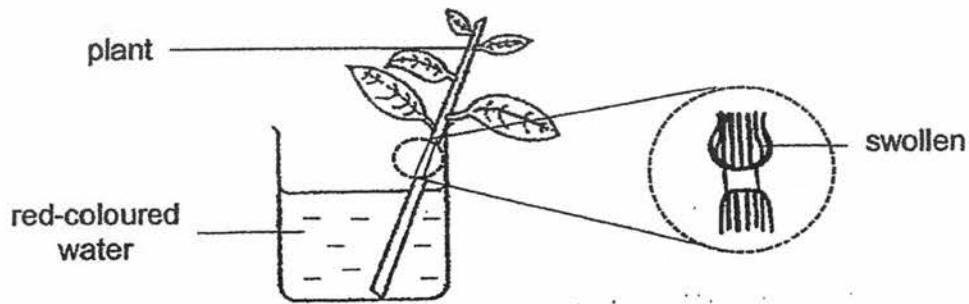

- (a) What would happen to the colour of the leaves after a few days? [1]

- (b) Give a reason for your answer in (a). [1]

- (c) Explain why the part just above the cut stem was swollen after a few days. [1]

(Go on to the next page)

SCORE	3
-------	---

- 31 The diagram below shows how substances A and B are transported from one part of the plant to another in the plant transport system.

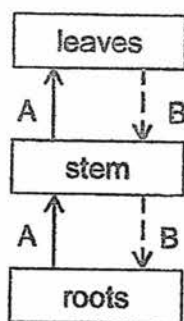

- (a) Identify substance B. [1]

- (b) What happens to substance A when it reaches the leaves? [1]

The diagram below shows the human circulatory system.

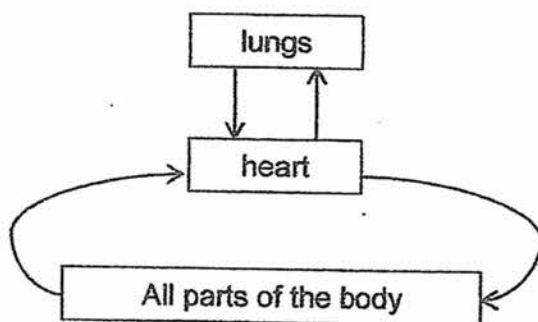

Compare the diagrams on the plant transport system and the human circulatory system.

- (c) State the difference in the direction in which food is transported in plants and humans. [1]

(Go on to the next page)

SCORE	3
-------	---

- 32 Ian caught two organisms C and D from his school pond and wanted to find out whether they were animals or plants. He filled four beakers 1, 2, 3 and 4 with pond water. He placed organism C in beakers 1 and 2 and organism D in beakers 3 and 4 as shown below.

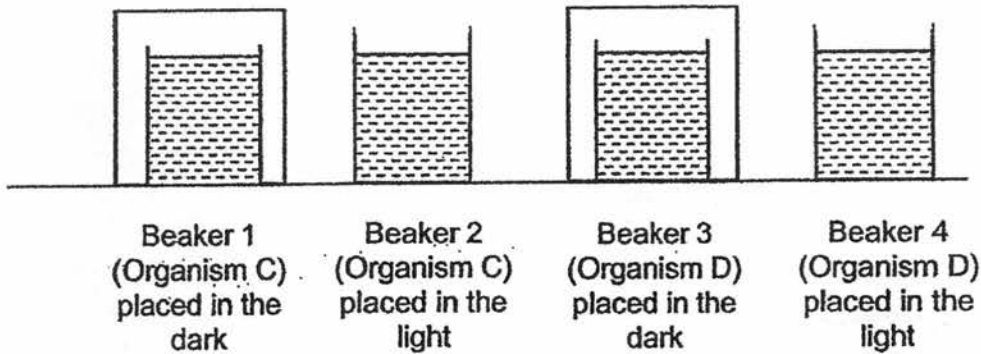

Ian added a drop of liquid A in each beaker. The table below shows the colour of liquid A in the presence of more oxygen or more carbon dioxide.

Colour of liquid A	More oxygen is present	More carbon dioxide is present
	blue	yellow

Ian recorded the colour of liquid A after the experiment as shown below.

Beaker	Colour of liquid A
1	yellow
2	yellow
3	yellow
4	blue

- (a) Based on the results, Ian concluded that organism C was an animal. [1]
Explain how he arrived at this conclusion.

- (b) Name the process that took place in beaker 4. Explain how this process caused the change in the colour of liquid A. [2]

(Go on to the next page)

SCORE	3
-------	---

- 33 Olivia conducted an experiment using two identical air-tight containers A and B as shown. Container A had a black surface while container B had a white surface.

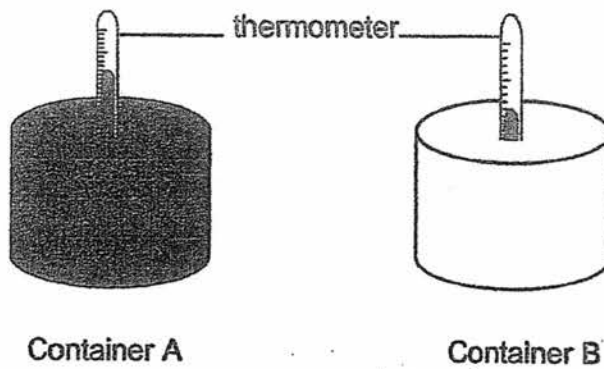

The readings on both thermometers were the same before Olivia placed the containers under the Sun. She recorded the change in the temperature of air in each container as shown in the graph below.

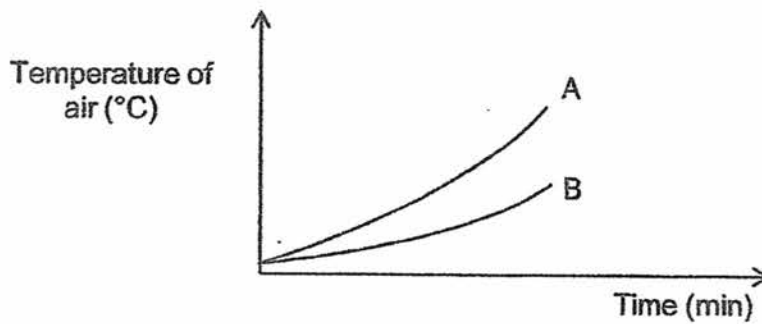

- (a) Line A represents the change in the temperature of air in Container A. [1]
What could Olivia conclude from her experiment?

(Go on to the next page)

SCORE	1
-------	---

Continue from Question 33

Bird P lives in a very cold habitat.

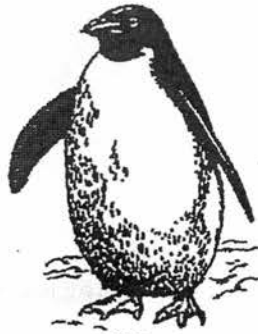

Bird P

- (b) Bird P usually stands with its back facing the Sun. Suggest a reason [1]
for such a behaviour.

- (c) Bird P puffs up the feathers when it gets colder. Explain how puffing [1]
up the feathers will help it to keep warm.

(Go on to the next page)

SCORE	2
-------	---

- 34 Joanna wrote down some information about the organisms found in her garden. The table below shows the information about the relationships of some organisms in Joanna's garden.

Organism	Information
M	A plant eater
N	Feeds on M and P
O	A predator of N
P	A plant eater
Q	Gets its energy directly from the Sun

- (a) Based on the information above, construct a food web, involving organisms M, N, O, P and Q, in the box below. [2]

- (b) One of the organisms was a plant and its population size had been decreasing over the past few months. Joanna wanted the plant population to increase. Without adding more plants, Joanna planned to introduce more of one type of organism.

Based on the information and food web above, which one of the organisms M, N, O, P or Q should Joanna add? Explain your answer. [3]

(Go on to the next page)

SCORE	5
-------	---

- 35 Diagram 1 below shows a magnet held near P which is tied to a string. It is then observed that P moved away from the magnet and a distance is maintained between them. A flame was then placed at one end of the magnet as shown in Diagram 2. After some time, P started to move towards the magnet and the distance between them decreased.

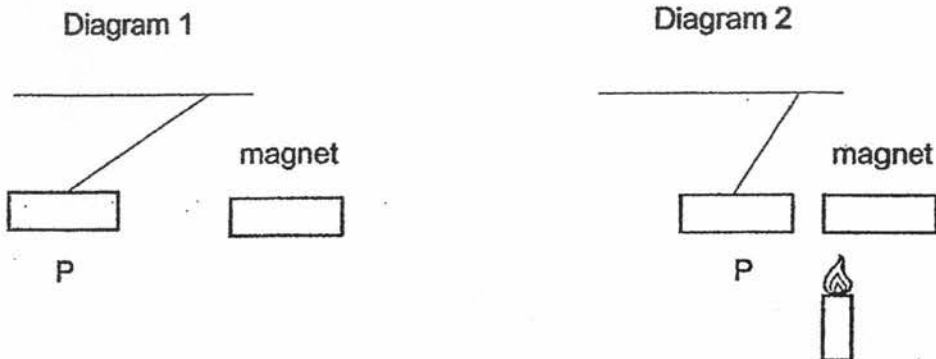

- (a) Based on the above observations, what is P likely to be? [1]

- (b) Give a reason for your answer in (a). [1]

- (c) In Diagram 2, give a reason why the distance between P and the magnet decreased. [1]

(Go on to the next page)

SCORE	3
-------	---

36 Helen shone a torch on a tin can from two different positions as shown in the diagram below.

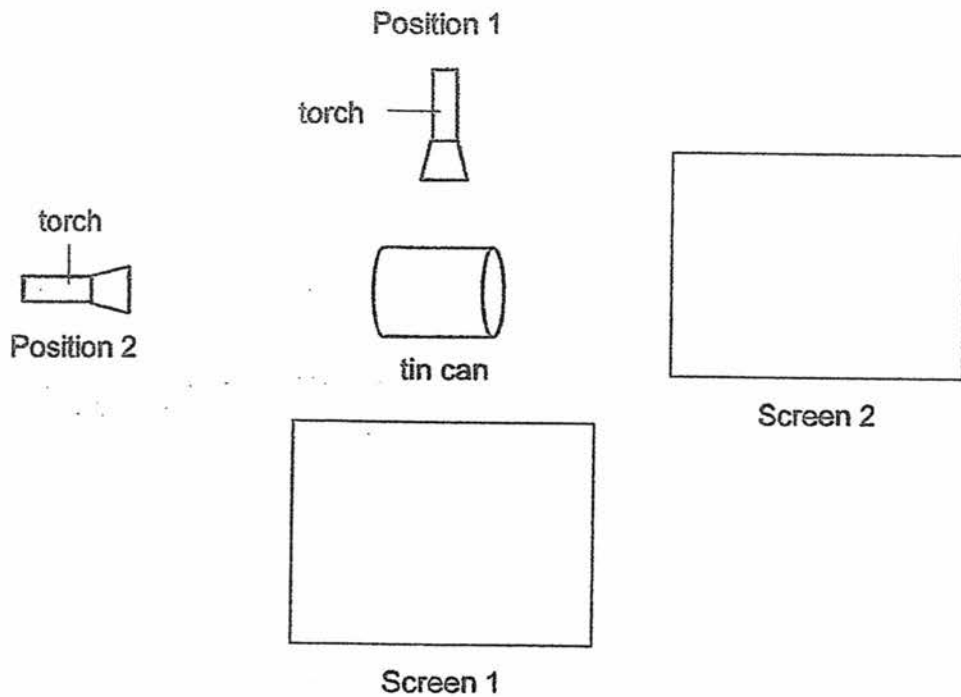

- (a) Draw the shadows that will be formed on the two screens, 1 and 2, [1]
respectively.
- (b) How is a shadow formed? [1]
- (c) If Helen was to move the tin can closer to position 2, what change [1]
would she observe about the shadow on screen 2?

(Go on to the next page)

SCORE	3
-------	---

- 37 Gabriel set up two set-ups below to find out how heat affects the temperature of the air. Both set-ups were placed in the same location.

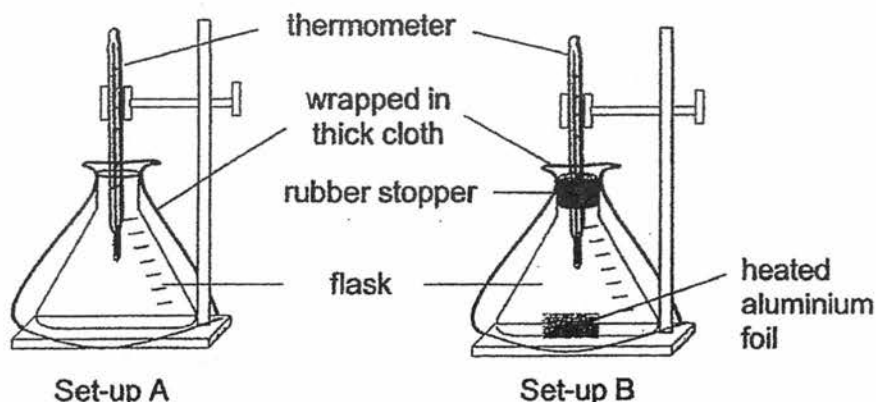

He recorded the changes in the temperatures in both set-ups over a period of 30 minutes in the table below.

Time (mins)	Set-up A (°C)	Set-up B (°C)
0	30	30
15	30	38
20	30	44
25	30	48
30	30	48

- (a) Why was there an increase in the temperature in set-up B from the start of the experiment to 25th minute of the experiment? [1]

- (b) Explain what happened in set-up B between the 25th and 30th minute. [1]

- (c) Gabriel was advised by his mother to put a lid on the pot while cooking the food. How does this make cooking faster? [1]

(Go on to the next page)

SCORE	3
-------	---

- 38 Rafiq set up circuit A as shown below using an eraser and a copper coin which are connected to the circuit at either position X or Y.

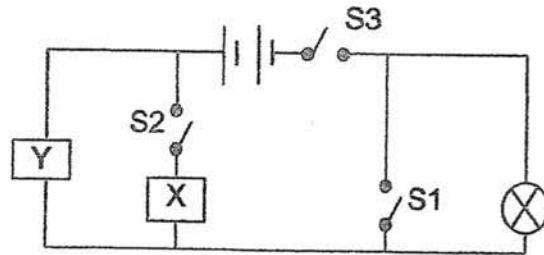

Circuit A

He closed some of the switches in the above circuit and his observations were recorded below.

Closed switches	Did the bulb light up?
S1 and S3	No
S2 and S3	Yes

- (a) Based on his observations, write down the positions, X and Y, of the two items used in circuit A. [1]

Items	Position
eraser	
copper coin	

Rafiq created circuit B as shown below, using similar batteries and bulbs. All the bulbs were lit up in this circuit.

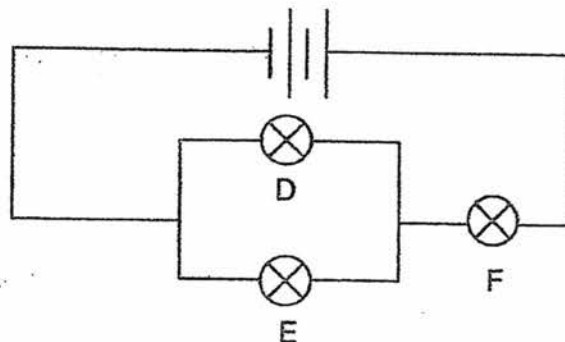

Circuit B

- (b) Rafiq removed one of the bulbs from circuit B and the other two bulbs did not light up. Which bulb did Rafiq remove? Explain your answer. [1]

(Go on to the next page)

Continue from Question 38

- (c) Rafiq wanted to rearrange circuit B so that all 3 bulbs would be brighter [2]
than before. Using the same number of batteries and bulbs, draw a circuit
diagram to show a new arrangement to make all 3 bulbs brighter.

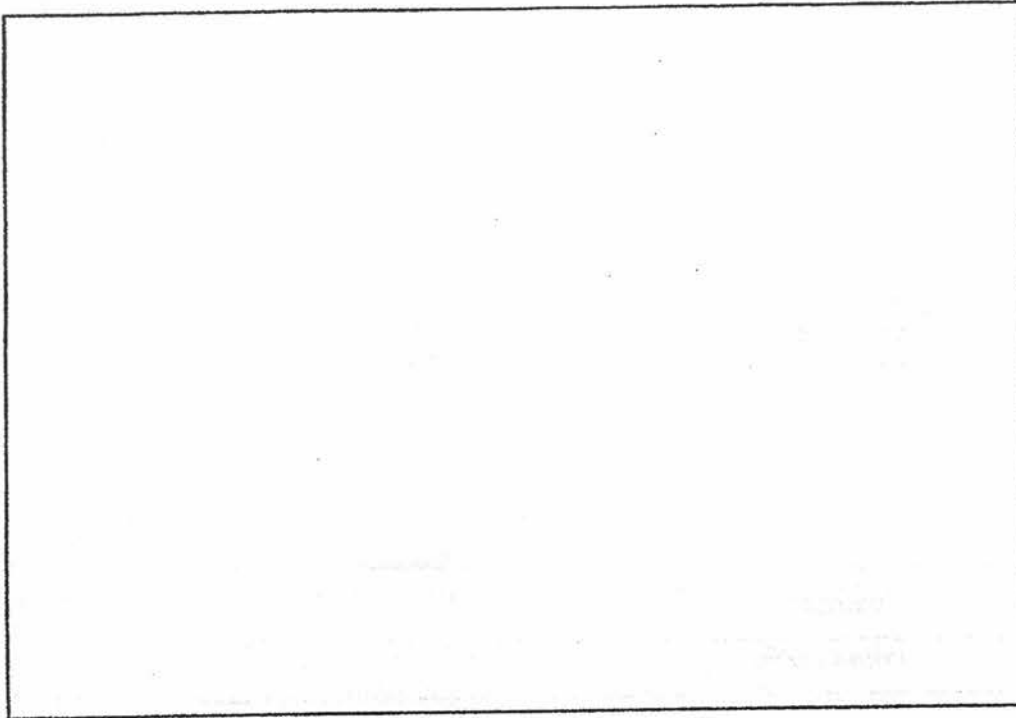

(Go on to the next page)

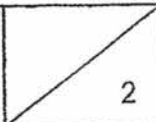
SCORE	
-------	---

- 39 A block is placed on a wooden table as shown in the diagram. The rubber band is stretched when the block is pulled against the rubber band.

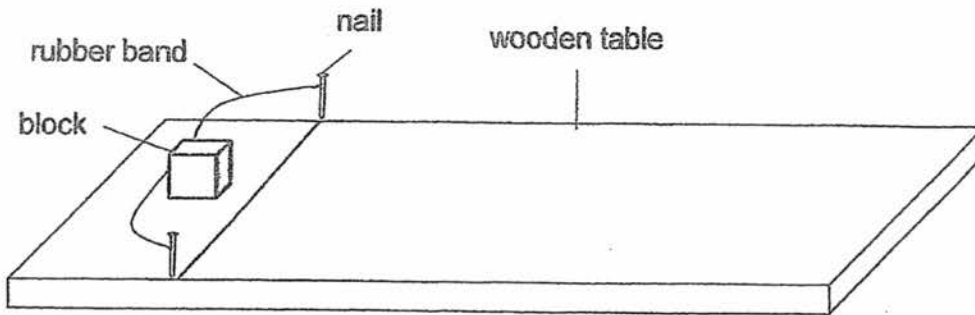

- (a) What are the two forces that are involved when the block is released? [1]

- (b) The wooden table is replaced by a marble table while all of the other variables are held constant. Will the block travel over a longer distance? Explain your answer. [1]

- (c) Bala decides to repeat the experiment using blocks of the same mass and material, but different area of contact with the wooden table.

His results are shown below.

Block	Area of contact with the table (cm ²)	Distance moved (cm)
G	100	12
H	120	12

- Based on Bala's results, did the area of contact with the table affect the friction on the block? Explain how you came to your conclusion. [1]

(Go on to the next page)

SCORE	3
-------	---

Continue from Question 39

Bala then wanted to find out how the distance from the block and the end of the wooden table (distance M) will affect the distance travelled by the block.

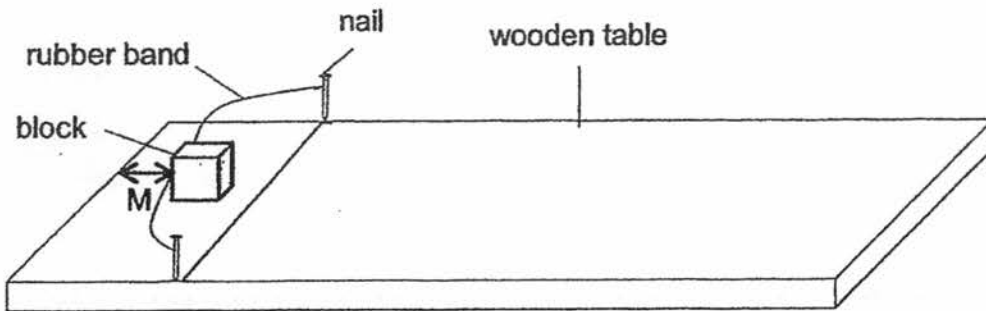

He recorded his findings in the table below.

Distance M (cm)	Distance travelled by the block (cm)
15	25
10	28
6	30

- (d) What is the relationship between distance M and the distance travelled by the block before it comes to a stop? [1]

- (e) Explain your answer in (d). [1]

(Go on to the next page)

SCORE	2
-------	---

- 40 Mrs Tan hung 3 wet towels of the same material out to dry at the same place as shown below.

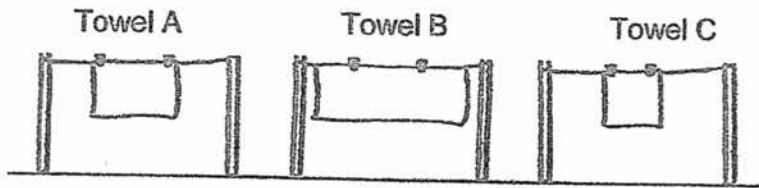

- (a) The graph below shows the amount of water left on each towel. Write down the correct letter (A, B or C) in the boxes below to indicate the graph for towels A, B and C. [1]

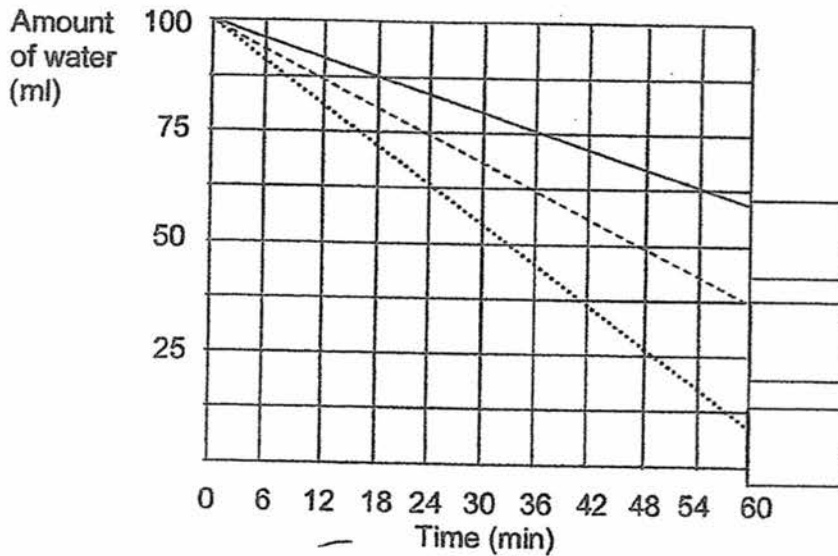

- (b) Which towel dried the fastest? Explain your answer. [1]

- (c) Write down one other variable that was kept the same in this experiment to ensure a fair test. [1]

(Go on to the next page)

SCORE	3
-------	---

- 41 Brian conducted an experiment with his toy car. He placed the toy car behind the starting point as shown below. When he released the toy car, it rolled down the ramp.

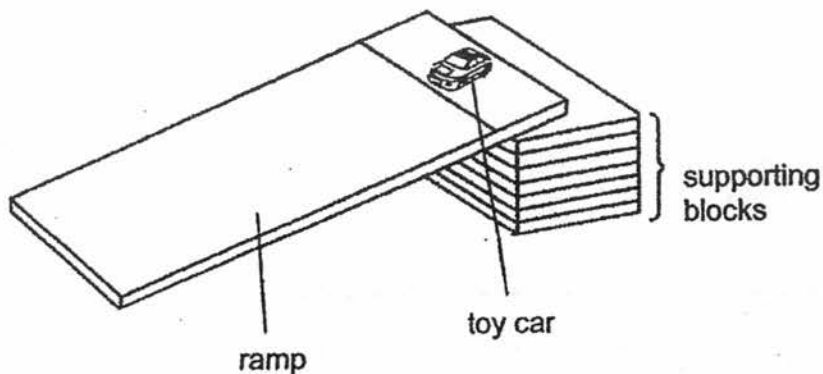

Brian also used a stop watch and two other toy cars of different masses in this experiment. He wanted to find out how the mass of the toy cars would affect the average time taken for the toy car to roll down from the starting point to the end of the ramp.

- (a) Describe how Brian could carry out his experiment. [2]

- (b) In his experiment, Brian decided to keep the height of the supporting blocks constant. Why would this make his experiment a fair test? [1]

- (c) What is the energy conversion as the toy car is moving down the ramp? [1]

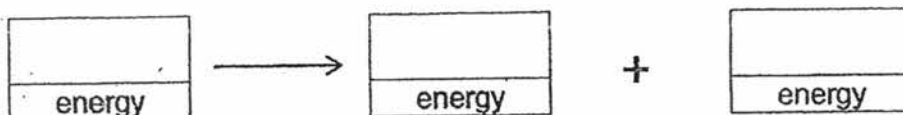

End of Booklet B

SCORE	4
-------	---

EXAM PAPER 2017

LEVEL : PRIMARY 6
SCHOOL : CATHOLIC HIGH SCHOOL
SUBJECT : SCIENCE

Booklet A

Q1	Q2	Q3	Q4	Q5	Q6	Q7	Q8	Q9	Q10	Q11	Q12	Q13	Q14
2	2	2	4	4	1	4	3	4	1	3	3	1	4
Q15	Q16	Q17	Q18	Q19	Q20	Q21	Q22	Q23	Q24	Q25	Q26	Q27	Q28
2	2	4	1	3	1	4	2	1	1	2	1	3	3

Booklet B

- Q29 (a) By wind
 (b) The wing-like structure helps the fruit to fly long distance so that it can be further away from its parent plant to avoid overcrowding.
- Q30 (a) The leaves would turn red.
 (b) The water is transported through the water-carrying tubes.
 (c) Food that is made by the leaves would not be able to move down the stem to be transported to other parts of the plant. As a result, this causes the food/starch to accumulate and swell at the opening/end of the cut.
- Q31 (a) Food for the plant
 (b) Water evaporates as the plant exchanges water for carbon dioxide during transpiration through the stomata in the leaves.
 (c) Food in leaves are transported in one direction while food in humans are transported through blood in a circulatory manner.
- Q32 (a) If the plant were placed in the light, the colour of liquid A would be blue as there would more oxygen present as plants photosynthesis but the colour of liquid A is yellow which is how Ian arrived at this conclusion.
 (b) Photosynthesis. Photosynthesis produces oxygen and when more oxygen is produced, the colour of liquid A would change to blue.
- Q33 (a) Olivia could conclude from her experiment that black absorbs more heat than white.
 (b) As the back of Bird P is black, it could absorb more heat than its front facing the sun as its front is white as Bird P needs heat as it lives in a cold habitat.
 (c) Puffing up the feathers will trap air and air is a poor conductor of heat. Hence, bird P will lose less body heat to the cold.

Q34 (a)

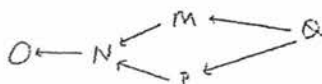

- (b) Q is the plant. With more N added, they will feed on more P and more M. Hence, there will be less P and M to feed on Q/plant.

- Q35 (a) P is likely to be a magnet.
 (b) P repelled from the magnet and only magnet repel.
 (c) The magnet lost some of its magnetism when heated.

- Q36 (a) screen 1 
 screen 2 

- (b) A shadow is formed when the path of light is fully or partially blocked by an opaque or translucent object.
 (c) The shadow would become bigger.

- Q37 (a) The heated aluminium foil caused the air in the flask to gain heat and the hot air did not escape due to the rubber stopper.
 (b) The temperature of air in the flask was the same as the heated aluminium foil so there was no transfer of heat between them.
 (c) By putting the lid on, the hot air will not escape and it reduces heat loss to the surrounding so the cooking will be faster.

- Q38 (a) Y, X
 (b) Bulb F. The circuit becomes open and the electric current is unable to flow through the circuit.

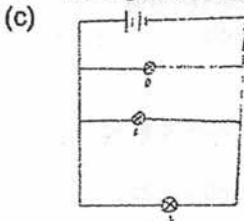

- Q39 (a) Elastic spring force and frictional force.
 (b) Yes, it will. The marble table is smoother than the wooden table so the frictional force between the marble table and block is lesser. Thus, the block travels over a longer distance.
 (c) No. When the area of contact with the table changed, it did not affect the friction on the block as the distance moved is the same.
 (d) As distance M decrease, the distance travelled by the block increases.
 (e) When distance M decreases, the rubber band with the block is pulled further backwards and there is more elastic spring force so the block will travel a greater distance before coming to a stop.

- Q40 (a) C
 A
 B
 (b) It has the greater amount of exposed surface area for water to evaporate the fastest. Hence, it has the least amount of water left.
 (c) Thickness of material

- Q41 (a) Step 1: release the car at the starting point 1
 Step 2: record the time taken for the car to reach the ground (repeat 3 times)
 Step 3: calculate the average time taken.

Do the same for the other car then compare the results.

- (b) If the height of the supporting blocks do not stay constant, some cars might have more gravitational potential energy than the other cars, thus, it will have a greater kinetic energy which would affect the time taken for a car to reach the ground.
- (c) Potential energy → Kinetic energy → Heat energy

3
END

SINGAPORE CHINESE GIRLS' SCHOOL (PRIMARY)

PRIMARY SIX PRELIMINARY ASSESSMENT 2017

NAME: _____ ()

DATE: 25 August 2017

CLASS: PRIMARY 6 SY / C / G / SE / P

Parent's Signature:

SCIENCE

BOOKLET A

28 questions

56 marks

Total time for Booklets A & B: 1 h 45 min

DO NOT OPEN THIS BOOKLET UNTIL YOU ARE TOLD TO DO SO.

FOLLOW ALL INSTRUCTIONS CAREFULLY.

Part I (56 marks)

For each question from 1 to 28, four options are given. One of them is the correct answer. Make your choice (1, 2, 3 or 4). Shade the correct oval (1, 2, 3 or 4) on the Optical Answer Sheet.

1. Victoria placed 4 different organisms in 4 separate tanks and provided them with different conditions as shown below.

Organisms	Oxygen	Carbon Dioxide	Food	Water
A	✓			✓
B	✓		✓	
C		✓		✓
D		✓	✓	

3 days later, only organisms A and C remained alive.

Based on the results, what can Victoria conclude about the 4 organisms? They can survive 3 days only if _____ is/are provided.

- (1) food
 - (2) water
 - (3) oxygen
 - (4) both water and oxygen
2. 4 pupils made the statements below.

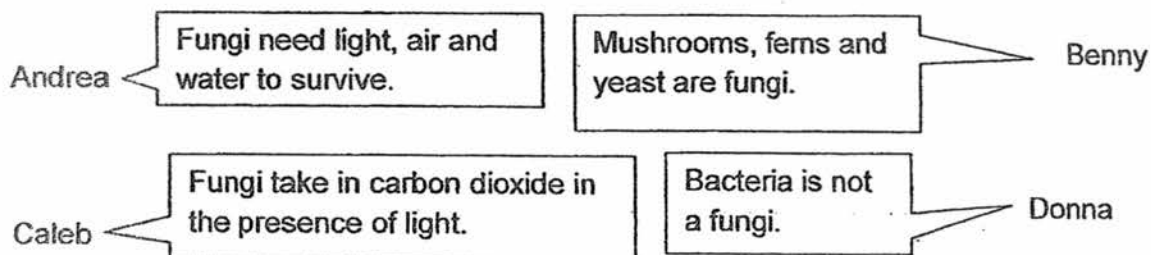

Which of the pupil/s is/ are correct?

- (1) Donna only
- (2) Andrea and Caleb only
- (3) Benny and Donna only
- (4) All of the above

3. Gavin wants to differentiate between mammals and birds. Which of the following questions should he ask to differentiate the 2 groups of animals?

	Questions
A	Does it fly?
B	Does it suckle its young?
C	What is its body covering?
D	How many legs does it have?

- (1) D only
 (2) A and D only
 (3) B and C only
 (4) A, B and C only
4. Grace has 4 materials, R, S, T and U, and their properties are stated in the table below.

	Strong	Flexibility	Waterproof	Good conductor of heat
Material R	✓		✓	
Material S		✓		✓
Material T			✓	
Material U	✓		✓	✓

- Which of the material(s) should Grace choose for making a water bottle that is durable and able to keep her water hot as long as possible?
- (1) Material R only
 (2) Material U only
 (3) Materials S and U only
 (4) Materials R, T and U only
5. A number of people were trapped in the lift and no air could enter or exit the lift. Which of the following best shows how the different gases in the air had changed in the lift after 15 minutes?

	Carbon dioxide	Water Vapour
(1)	Increase	Increase
(2)	Increase	No change
(3)	Decrease	Decrease
(4)	Decrease	Increase

8. Devi set up the circuit below with 3 batteries and 4 similar bulbs, A, B, C and D.

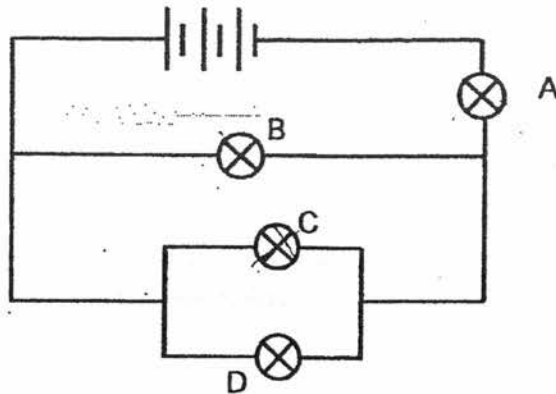

Which of the following will Devi observe if one bulb is fused?

	Fused bulb	Bulbs that remain lit
(1)	A	C and D only
(2)	B	A and D only
(3)	C	A and B only
(4)	D	A, B and C only

9. Study the following food web carefully.

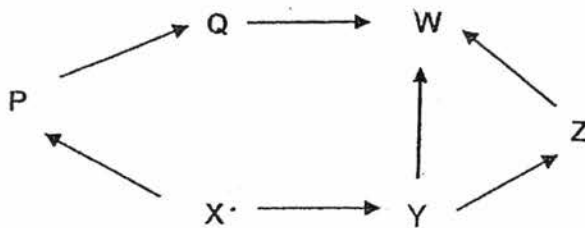

If the population of Y is removed suddenly, which of the following is likely to happen?

- (1) Population of Q will remain the same.
- (2) Population of X will decrease in number.
- (3) Population of W will increase in number.
- (4) Population of Z will decrease in number.

10. Study the following food web carefully.

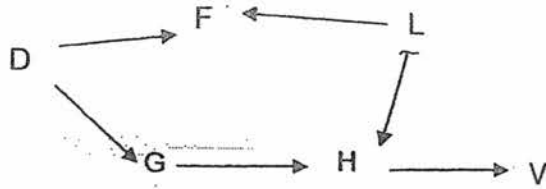

Which of the organism/s is/are food producer/s?

- (1) Organism D only
- (2) Organism V only
- (3) Organisms D and L only
- (4) Organisms F and V only

11. Uncle Willy counted the number of organisms living in his garden and plotted a bar graph as shown below.

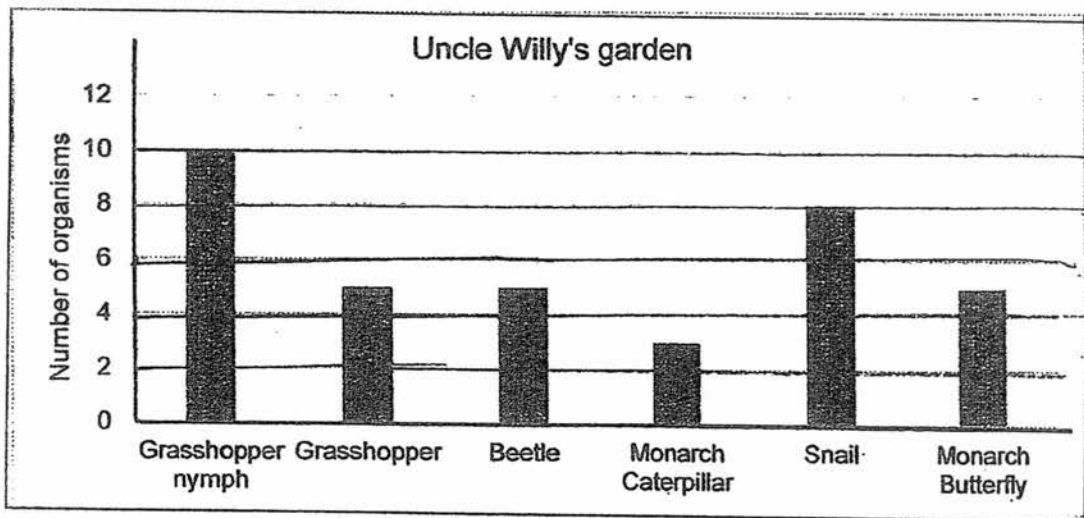

Based on the bar graph above, how many population/s is/are there in the garden?

- (1) 1 population
- (2) 5 populations
- (3) 6 populations
- (4) 4 populations

12. Zoe compared the seashore and pond habitats and listed the characteristics in the table below.

Characteristics	Seashore	Pond
Type of water	Salty	Fresh
Amount of sunlight	Low	High
Types of plants	Coconut trees and seaweed	Hydrilla and Water hyacinth
Types of animals	Crabs, Fish and Mudskipper	Frogs and Pond skater

Which one of the characteristics was wrongly observed?

- (1) Type of water
 (2) Amount of sunlight
 (3) Types of plants
 (4) Types of animals
13. Bryce set up the experiment below.

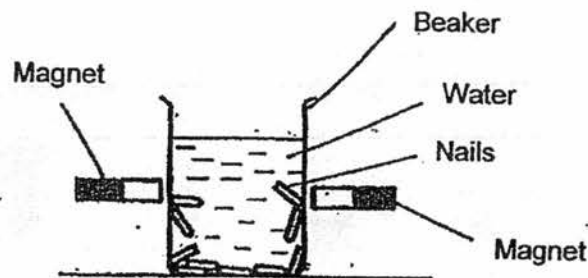

He observed that the magnets could only attract a few nails and gave a few reasons below.

- A: Some of the nails are not magnetic.
 B: The magnets are repelling one another.
 C: The magnets are not strong enough to attract all the nails.

Based on the observations above, which of the following statements is/are likely to be correct?

- (1) A only
 (2) B and C only
 (3) A and C only
 (4) A, B and C

14. The diagram below shows 3 different rings, D, E and F, placed through a smooth plastic rod randomly.

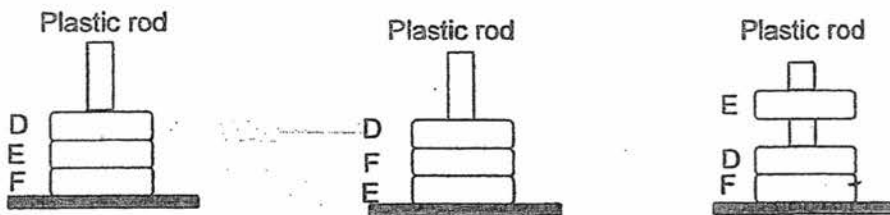

Based on the observations above, which of the following statements is definitely true?

- (1) 2 rings are magnets.
 - (2) Only 1 ring is a magnet.
 - (3) All the rings are non-magnetic.
 - (4) None of the rings are magnets.
15. Noel placed 2 wooden blocks, A and B, at different positions on a slope. Block A is bigger and heavier than Block B.

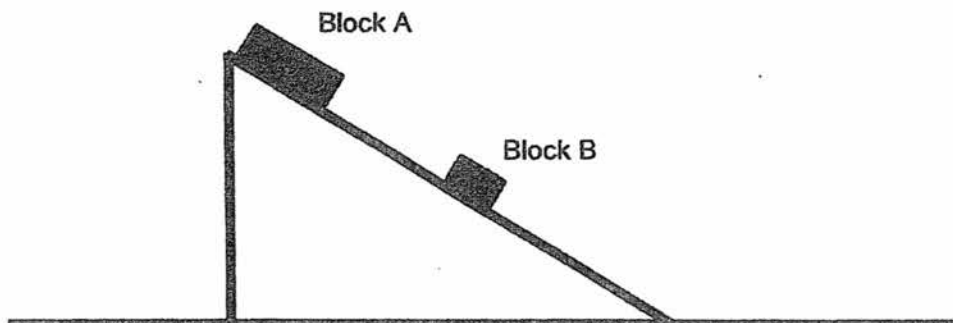

Noel made the following statements:

- A: There are no forces acting on the blocks.
 B: Block A has greater gravitational force acting on it than Block B.
 C: There is no frictional force acting on the blocks when they are not moving.
 D: There is no frictional force acting on the blocks when they slide down the slope.

Which of the following statements is/are correct?

- (1) A only
- (2) B only
- (3) B and C only
- (4) A and D only

16. Mrs Goh set up the experiment below with sandpaper tile and a plastic tile. She then measured the amount of force used to pull 2 wooden blocks of different masses, A and B, on both surfaces using a spring balance.

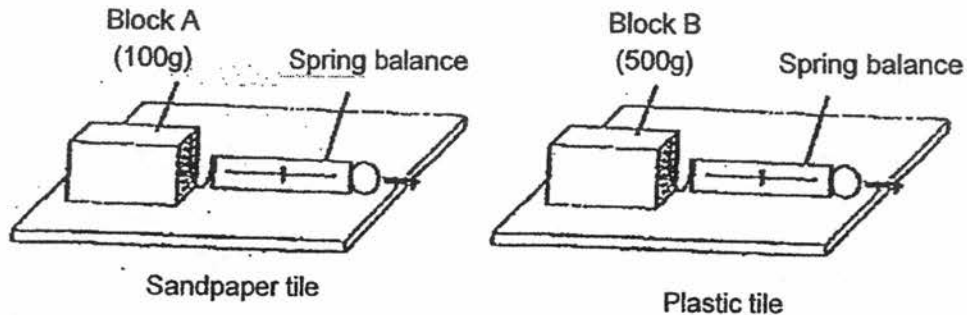

Which of the following is the most likely conclusion?

- (1) It requires more force to pull the Block A on the sandpaper tile than Block B on the plastic tile.
 - (2) It requires more force to pull Block B on the plastic tile than Block A on the sandpaper tile.
 - (3) It requires the same amount of force to pull both Blocks A and B on both surfaces.
 - (4) It is not possible to draw a conclusion based on the experiment.
17. Mr Wong needed to clear the forest to make way for the development of a shopping mall. He considered burning down the trees as it required less effort than cutting down the trees. He stated some of the possible results of burning down the trees as shown below.

- A: Soil erosion
- B: Air pollution
- C: Loss of habitats for some organisms
- D: Global warming

Which of the following shows the possible results of burning the trees?

- (1) A and B only
- (2) B and C only
- (3) B, C and D only
- (4) All of the above

18. Study the life cycles of 2 organisms below.

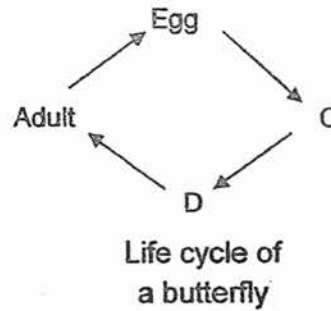
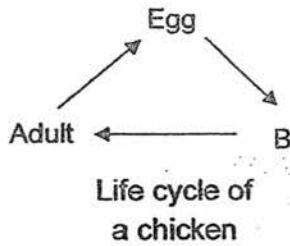

4 pupils made the following statements:

Putra	Stage D does not feed at all.
Bryce	Stages B and C involve moulting.
Xavier	A butterfly spends part of its life cycle in water.
Hossan	The young of a chicken resembles its adult but that of a butterfly does not.

Whose statements is/are definitely true?

- (1) Putra only
 (2) Putra and Hossan only
 (3) Bryce and Xavier only
 (4) All of the above

19. Study the 2 diagrams below.

Human reproductive system

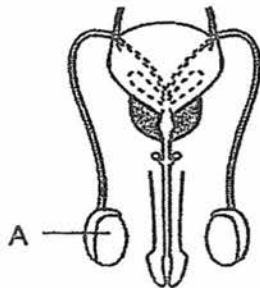

Plant reproductive system

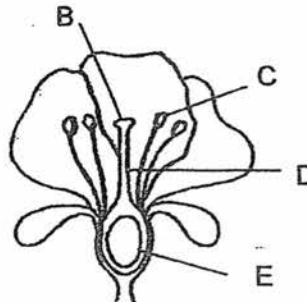

Which of the following parts above has a similar function as Part A?

- (1) B
 (2) C
 (3) D
 (4) E

20. Study the family tree below.

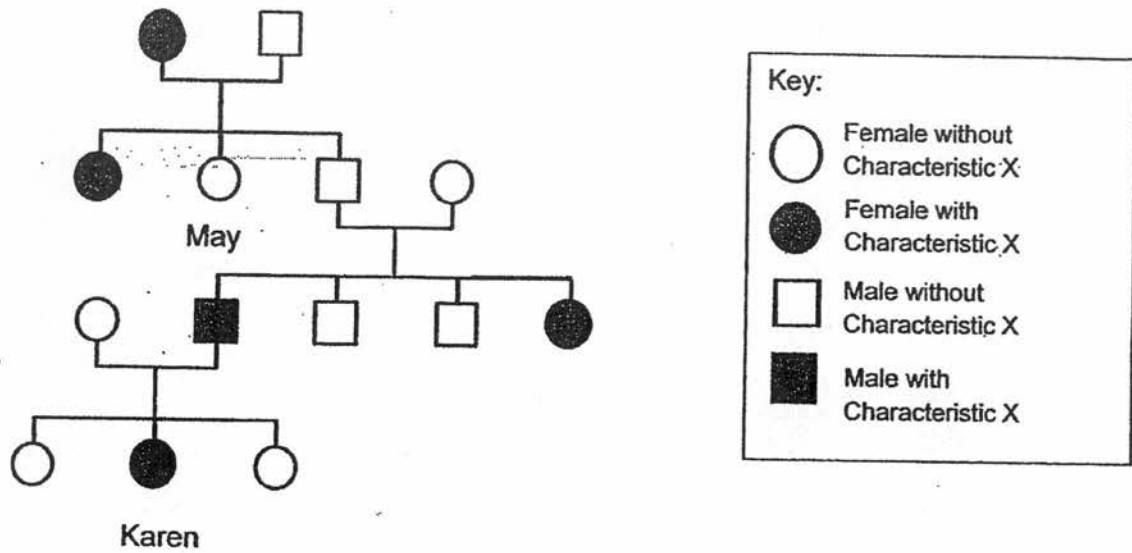

Based on the family tree above, which of the following statements is true?

- (1) Karen has 2 aunts.
 - (2) May has 3 nephews.
 - (3) Karen's grandmother has Characteristic X.
 - (4) It is not possible to have Characteristic X when the parents do not have it.
21. Mdm Sutjah set up the experiment as shown below. There was 100 cm^3 of water, a 30 cm^3 cube and 70 cm^3 of air in the container originally.

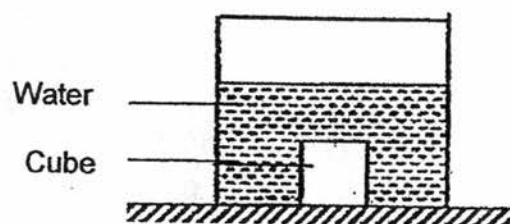

What is the volume of the air in the container when she removes the 30 cm^3 cube?

- (1) 100 cm^3
- (2) 110 cm^3
- (3) 140 cm^3
- (4) 170 cm^3

22. Study the graph below carefully.

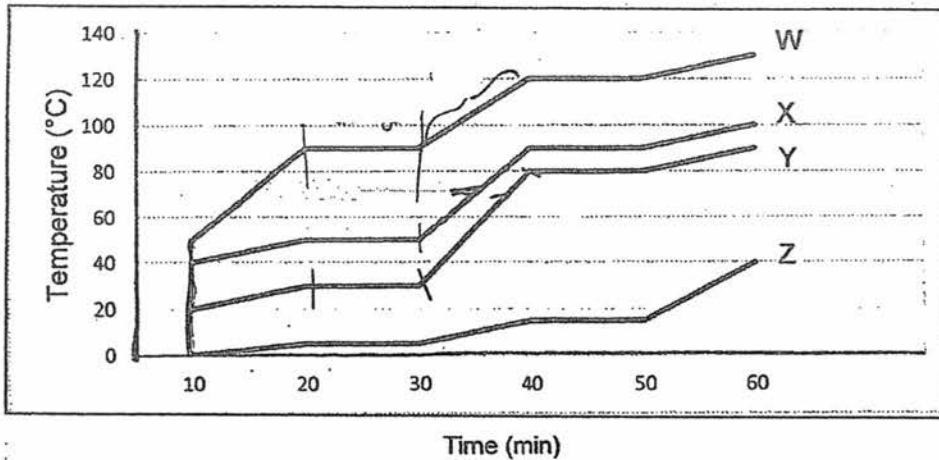

Which of the following substances, W, X, Y or Z, is/are in a liquid state at 70°C?

- (1) W only
 (2) X only
 (3) Z only
 (4) X and Y only

23. Jack set up the experiment as shown below.

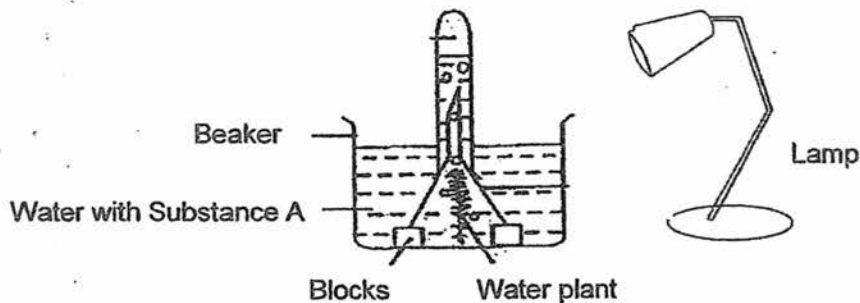

He adds Substance A which removes carbon dioxide in the water. Any carbon dioxide given out by the plant is absorbed by Substance A immediately. He switches on the lamp and measures the amount of oxygen in the water.

What will Jack observe after an hour?

- A: The water plant will die.
 B: Amount of oxygen will not change.
 C: Amount of oxygen in the water will increase.
 D: Amount of oxygen in the water will decrease.

- (1) B only
 (2) C only
 (3) D only
 (4) A and D only

24. Jaylyn wanted to carry out a few experiments and listed the variables in the table below.

A	Number of plants
B	Type of soil
C	Type of plants
D	Amount of water

She wrote down a few aims of the different experiments and the variables to be changed. Which of the following experiments will enable Jaylyn to achieve the aim of an experiment?

	Aim of experiment	Variables to be changed
(1)	To find out if the amount of nutrients affects the rate of photosynthesis.	B only
(2)	To find out if the type of soil affects plant growth.	C only
(3)	To find out if the amount of water given to the plant affects the rate of photosynthesis.	D only
(4)	To find out if different types of plants have different rates of photosynthesis.	A only

25. The diagram below shows 4 test tubes, W, X, Y and Z, filled with different volumes of water and heated to different temperatures.

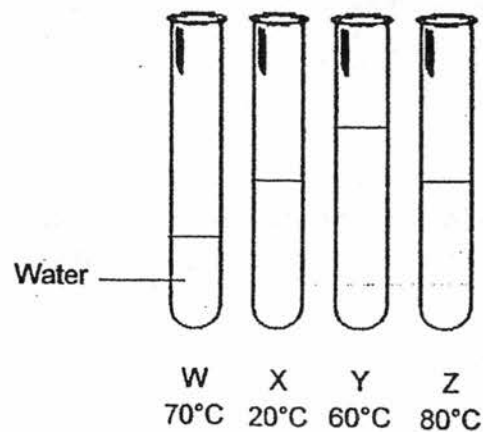

Which of the following statements is true?

- (1) Test tube Z has the most heat energy.
- (2) Test tube W has the least heat energy.
- (3) Test tube Y has less heat energy than test tube Z.
- (4) Test tube X has less heat energy than test tube Z.

26. Sally set up the experiment as shown below. The cup and ball are both 12cm in diameter.

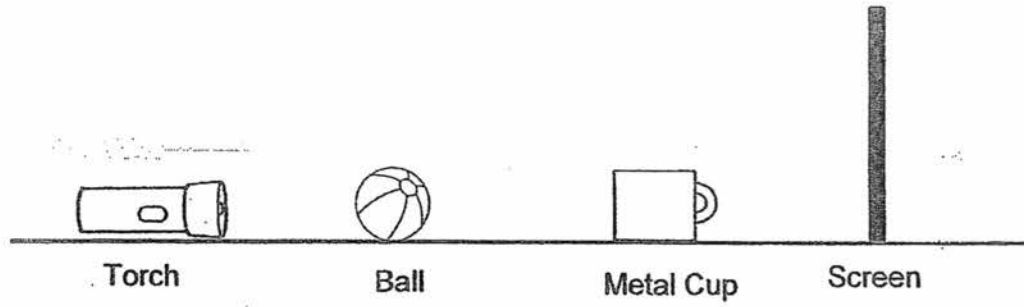

Which of the following shows the correct shadow formed on the screen?

(1)

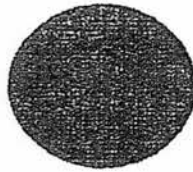

(3)

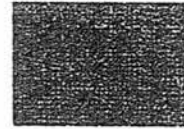

(2)



(4)

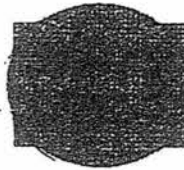

27. Mdm Haliya had 3 different materials of the same thickness. She shone a torch at them separately in a dark room and drew the intensity of light that passed through the materials using arrows.

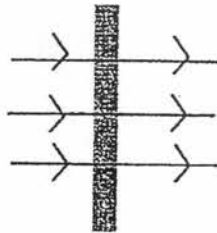

Material A

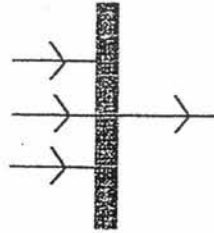

Material B

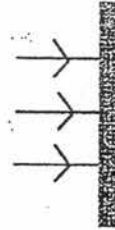

Material C

Based on the observations above, which of the following best identifies the 3 materials?

	Material A	Material B	Material C
(1)	Clear glass	Tracing paper	Wood
(2)	Clear glass	Wood	Tracing paper
(3)	Wood	Tracing paper	Clear glass
(4)	Tracing paper	Wood	Clear glass

28. Which of the options below shows how one form of energy is converted to another correctly?

	Electrical energy → Kinetic energy	Potential energy → Kinetic energy	Kinetic energy → Potential energy
(1)	Switching on a fan	Releasing a compressed spring	Running up a hill
(2)	Switching on a fan	Running up a hill	Releasing a compressed spring
(3)	Switching on a television	Releasing a compressed spring	Running up a hill
(4)	Switching on a television	Running up a hill	Releasing a compressed spring

End of booklet A
Please check your work.