



# RED SWASTIKA SCHOOL

## 2016 PRELIMINARY EXAMINATION SCIENCE PRIMARY 6

Name : \_\_\_\_\_ ( )

Class : Primary 6/ \_\_\_\_\_

Date : 29 August 2016

### BOOKLET A

Total time for Booklets A & B: 1h 45 min

Booklet A: 30 questions (60 marks)

**Note:**

1. Do not open the booklet until you are told to do so.
2. Read carefully the instructions given at the beginning of each part of the booklet.
3. Do not waste time. If the question is too difficult for you, go on to the next question.
4. Check your answers thoroughly and make sure you attempt every question.
5. In this booklet, you should have the following:
  - a. Page 1 to Page 22
  - b. Questions 1 to 30

**Section A**

For Questions 1 to 30, choose the most suitable answer and shade its number in the OAS provided.

1. Look at the flowchart below carefully.

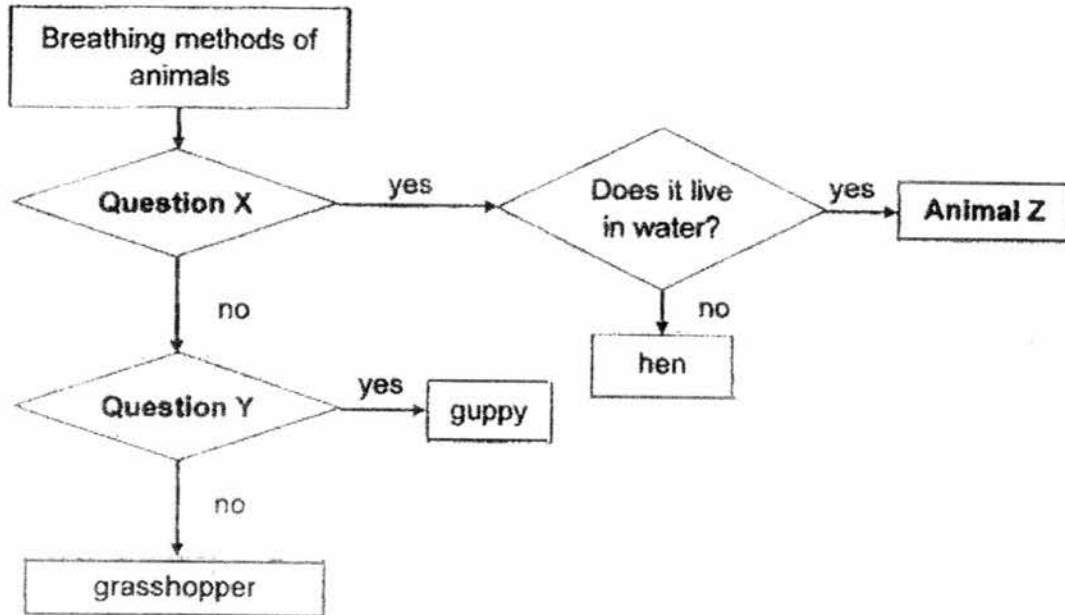

Which of the following describes X, Y and Z?

	<b>Question X</b>	<b>Question Y</b>	<b>Animal Z</b>
(1)	Does it have feathers?	Does it have scales?	duck
(2)	Does it breathe with lungs?	Does it have gills?	dolphin
(3)	Does it breathe through its skin?	Does it have gills?	snake
(4)	Does it breathe with gills?	Does it have breathing tubes?	seal

2. Usha observed some animals in her garden. She recorded her observations in the table shown below.

Observation	cat	bird	butterfly	millipede
Has fur	yes	no	no	no
Has feathers	no	yes	no	no
Has wings	no	yes	yes	no
Has two legs	yes	yes	no	no

Which one of the following animals was described wrongly?

- (1) cat
  - (2) bird
  - (3) butterfly
  - (4) millipede
3. The diagrams below show the human reproductive systems.

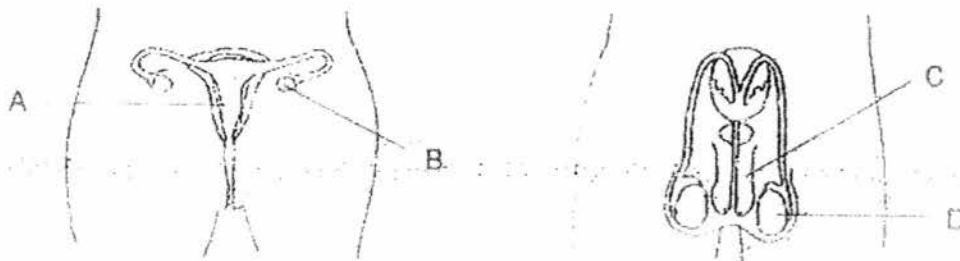

Where are the eggs and sperms produced?

	Eggs	Sperms
(1)	A	C
(2)	B	C
(3)	B	D
(4)	D	B

4. Mrs Chan planted some seeds in two similar pots. She then left the two pots by the window and watered them with the same amount of water every day. The table below shows the number of seeds she planted in each of the pots.

Pot	X	Y
Number of seeds	5	25

The seeds germinated and she measured the average height of the seedlings daily for two weeks. The graph below shows her results.

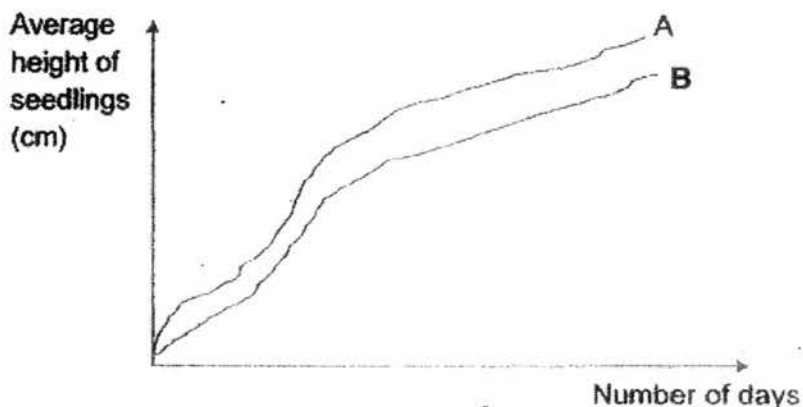

Mrs Chan then asked her four students, Ai Meng, Brendon, Chrischelle and Danu, to explain the graph.

**Ai Meng:** Line A shows the average height of the seedlings in pot X. As there is no overcrowding, the seedlings need not compete for sunlight. Hence their stems are taller and thinner.

**Brendon:** Line B shows the average height of the seedlings in pot Y. Due to overcrowding, the seedlings need to compete for sunlight. Hence their stems are shorter and thicker.

**Chrischelle:** Line A shows the average height of the seedlings in pot Y. Due to overcrowding, the seedlings need to compete for sunlight. Hence their stems are taller but thinner.

**Danu:** Line B shows the average height of the seedlings in pot X. As there is no overcrowding, the seedlings need not compete for sunlight. Hence their stems are shorter and thicker.

Which of the students made the correct statements?

- (1) Ai Meng only
- (2) Chrischelle only
- (3) Ai Meng and Brendon only
- (4) Chrischelle and Danu only

5. Hannah wanted to find out the amount of leaves eaten by an insect in the various stages of its life cycle. She conducted an experiment and plotted a graph according to the sequence of some of the stages in its life cycle as shown below.

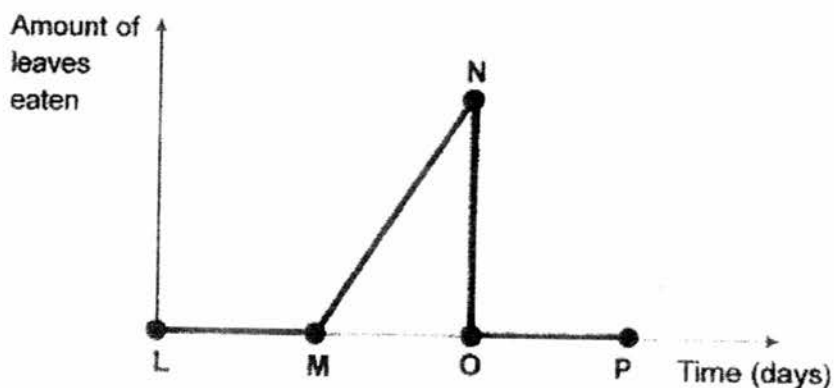

Which of the following represents the egg, larval and pupal stages of the insect?

	egg stage	larval stage	pupal stage
(1)	NOP	MN	LM
(2)	NO	LMN	OP
(3)	LMN	NO	OP
(4)	LM	MN	NOP

6. Professor Javier extracted a cell from organism X as shown in the diagram below. He wanted to study the structure that contains the substance which is able to trap light energy.

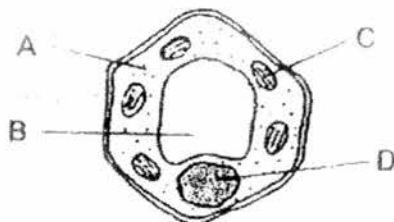

Which part should Professor Javier focus on for his research?

- (1) A
- (2) B
- (3) C
- (4) D

7. The diagram below shows how blood flows in certain parts of the body a few hours after a meal.

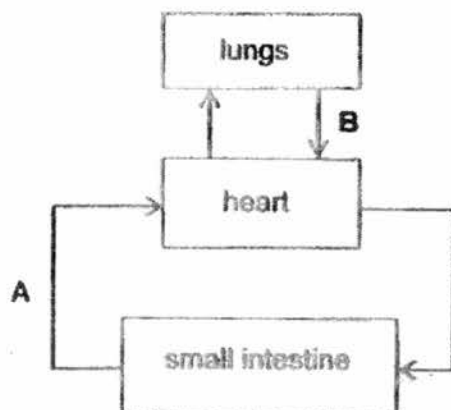

Which of the following correctly shows the comparison between the blood flowing at A and the blood flowing at B?

	<b>Blood flowing at A</b>	<b>Blood flowing at B</b>
(1)	more carbon dioxide, more digested food	less carbon dioxide, less digested food
(2)	more carbon dioxide, less digested food	less carbon dioxide, more digested food
(3)	less carbon dioxide, more digested food	more carbon dioxide, less digested food
(4)	less carbon dioxide, less digested food	more carbon dioxide, more digested food

8. Scott removed the outer ring of a stem from a plant in his garden as shown below. As a result, the tubes carrying food and water were removed.

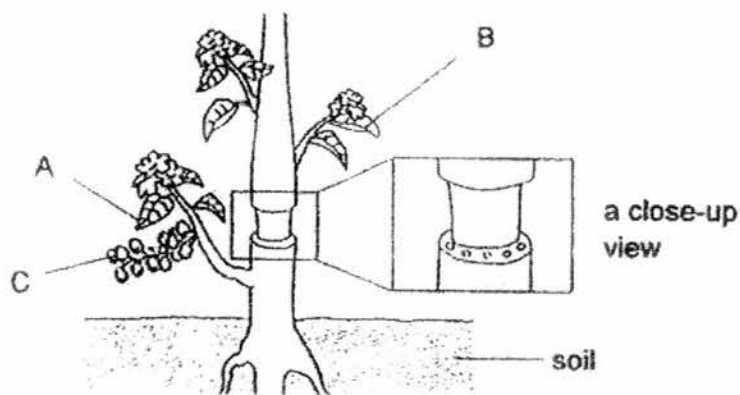

It was observed that C grew bigger after one week. Which of the following statements best explains the observation?

- (1) Food is made by C itself.
  - (2) Food is absorbed by C from the soil.
  - (3) Food is transported from A to C.
  - (4) Food is transported from B to C.
9. Gupta counted the number of organisms in a particular habitat and recorded the data in the table below.

Organisms	Number of organisms
Water lilies	8
Duckweeds	12
Guppies	3
Dragonfly nymphs	4
Wrigglers	8
Dragonflies	2
Mosquitoes	3

Based on the table above, which one of the following is correct?

- (1) There are 5 communities.
- (2) There is 1 community with 5 populations.
- (3) There are 40 populations living in the habitat.
- (4) There are 7 populations with a total of 40 organisms

The diagram represents a food web in a habitat with organisms R, S, T, U, V, W and X. Study the diagram and answer question 10 and 11.

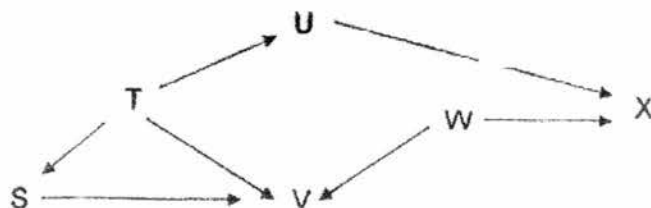

10. Which of the following statements about the food web are true?
- A: X is a carnivore.
  - B: T is the only producer.
  - C: V is a predator of S.
  - D: U and S are herbivores.
- (1) A and B only  
(2) C and D only  
(3) A, B and D only  
(4) A, C and D only
11. The whole population of X is killed by Man due to overhunting. Which one of the following will most likely happen after some time?
- (1) The population of S will increase.
  - (2) The population of T will decrease.
  - (3) The population of U will decrease.
  - (4) The population of W will decrease.



12. Daria obtained water samples from different parts of a river, K, L and M, as shown below. The arrow  $\rightarrow$  shows the direction of flow of the river.

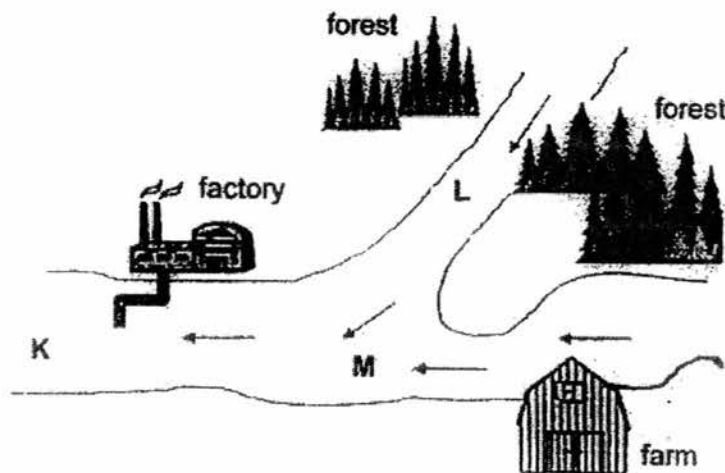

She put 30 fishes into each water sample and recorded her observations in the table below.

water sample from	number of fish alive after two weeks
K	5
L	30
M	15

What can Daria conclude from her observation?

- (1) The water is the most polluted at L.
  - (2) The water is the least polluted at M.
  - (3) The factory waste caused most of the fish to die in the water sample taken from M.
  - (4) The factory waste and the pesticide from the farm caused most of the fish to die in the water sample taken from K.
13. Which of the following correctly describes the direct source of energy received by the angšana tree and the mushroom?

	angsana tree	mushroom
(1)	sun	rotting log
(2)	soil	sun
(3)	soil	rotting log
(4)	sun	sun

14. Zalina used the following set-up to conduct an experiment. She kept the set-ups in a dark room for one before placing the set-ups in the open field during the day. After the experiment, Zalina conducted a starch test on a leaf from each plant.

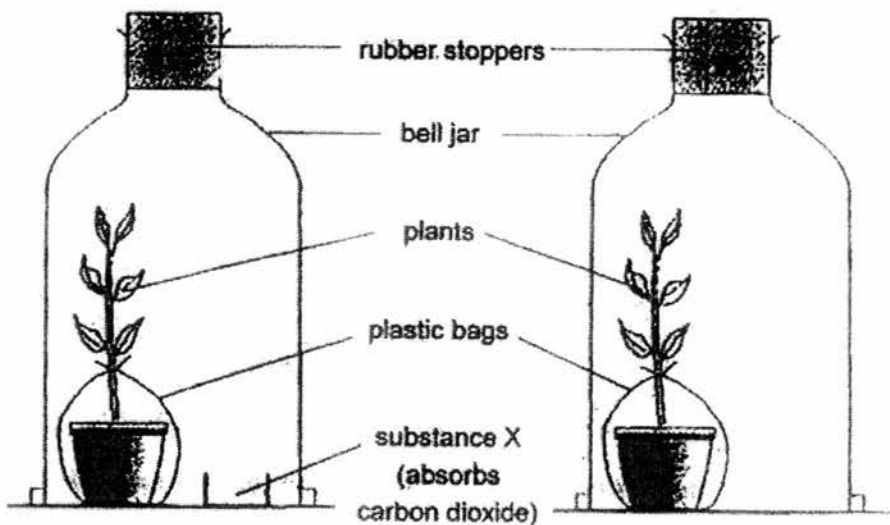

What was the aim of Zalina's experiment?

The aim of her experiment was to find out if plants \_\_\_\_\_

- (1) give out oxygen during photosynthesis
  - (2) give out carbon dioxide during photosynthesis
  - (3) need oxygen to carry out photosynthesis
  - (4) need carbon dioxide to carry out photosynthesis
15. Prima Supermarket encourages shoppers to bring their own plastic bags or the supermarket will sell a paper bag, which is made from recycled paper, at \$0.10 each for the shoppers to store their groceries.

Mdm Krishna listed the characteristics of the paper bag sold by the supermarket as shown below.

- A: Tears easily.
- B: Absorbs water.
- C: Does not allow light to pass through.

Which characteristic(s) of the paper bag made Mdm Krishna decide to bring her own plastic bag since her groceries are often heavy and it is always raining?

- (1) A only
- (2) B only
- (3) A and B only
- (4) A, B and C

18. The diagram below shows a handphone with a screen.

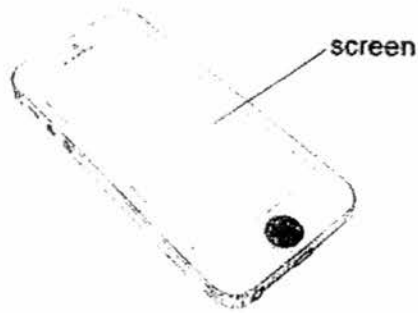

Study the properties of the four materials below.

Material	Property of material		
	Hard	Transparent	Flexible
A	yes	yes	no
B	yes	no	no
C	no	yes	yes
D	no	no	yes

Which material is the most suitable for making the screen?

- (1) A
- (2) B
- (3) C
- (4) D

17. Gary lived overseas. When he entered his car one morning, he found that the inner surface of his car window was covered with tiny water droplets.

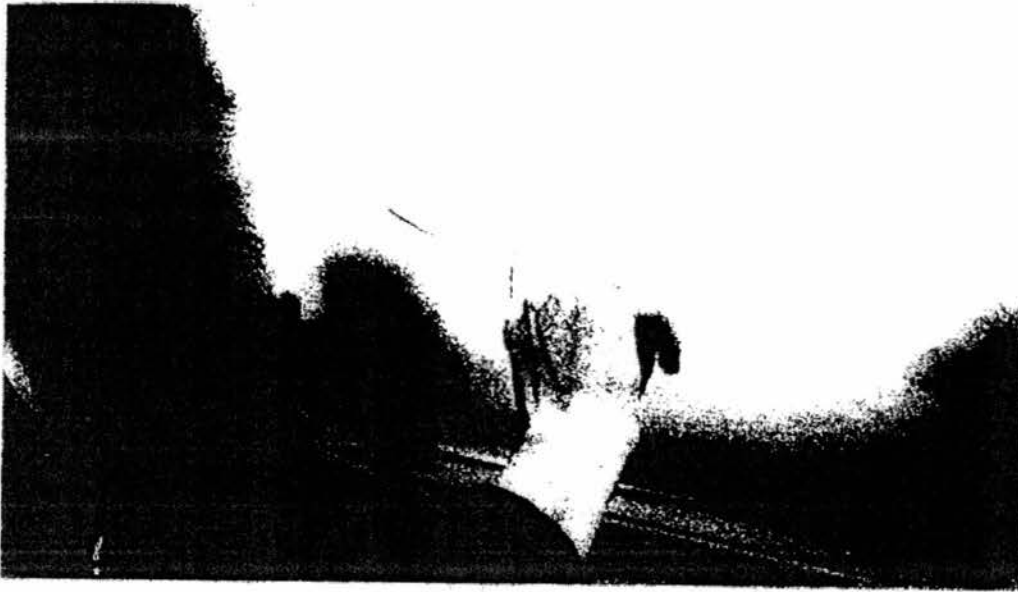

Which of the following statements are true?

- A. The temperature inside the car was higher than the temperature outside the car.
- B. The temperature outside the car was higher than the temperature inside the car.
- C. Lowering the temperature in the car will slow down the formation of tiny water droplets on the inner surface of the window.
- D. Increasing the temperature in the car will slow down the formation of tiny water droplets on the inner surface of the window.

- (1) A and C only
- (2) A and D only
- (3) B and C only
- (4) B and D only

18. A simple experiment with an ice cube was conducted in the Science laboratory. A pinch of substance X was placed on the ice cube and left there for five minutes. After five minutes, a hole was observed in the middle of the ice cube.

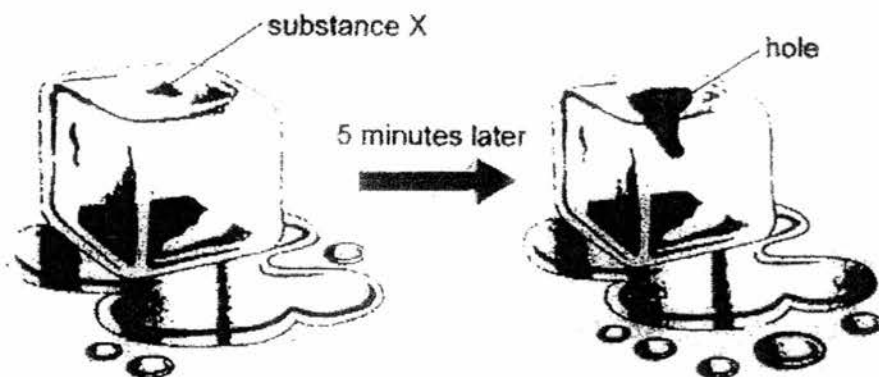

What does the experiment show?

- (1) Substance X causes the boiling point of water to be lower.
  - (2) Substance X causes the freezing point of water to be lower.
  - (3) Substance X causes the freezing point of water to be higher.
  - (4) Substance X causes the melting point of ice to remain the same.
19. The Christmas tree below was decorated with Christmas lighting. When one of the light bulbs on the trees fused, the rest of the light bulbs remained lit.

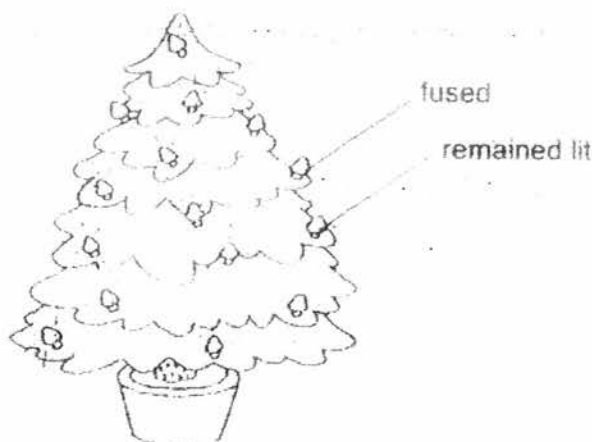

What does this show?

- (1) There were many batteries used for the Christmas tree.
- (2) There were many switches used for the Christmas tree.
- (3) The bulbs in the Christmas tree were arranged in series.
- (4) The bulbs in the Christmas tree were arranged in parallel.

20. The diagram below shows an electric circuit containing three similar batteries and three similar bulbs.

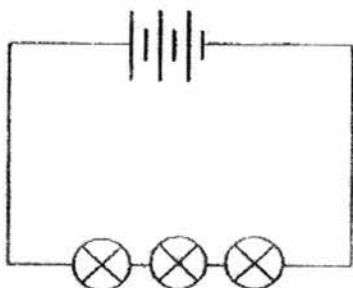

Which of the following actions will increase the brightness of each bulb?

- A: Arrange the bulbs in parallel.
- B: Increase the distance between each bulb.
- C: Reduce the number of bulbs in the circuit.
- D: Increase the number of batteries in the circuit.

- (1) A and B only
- (2) C and D only
- (3) A, C and D only
- (4) B, C and D only

21. In an electrical circuit, all bulbs were initially lit. The table below shows which bulb(s) would continue to light up when one of the bulbs had fused.

Fused bulb	Bulb(s) that continued to light up
A	None
B	A, C and D
C	A, B and D
D	None

Based on the table above, which one the following circuits was used?

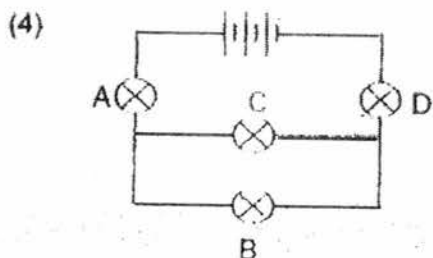
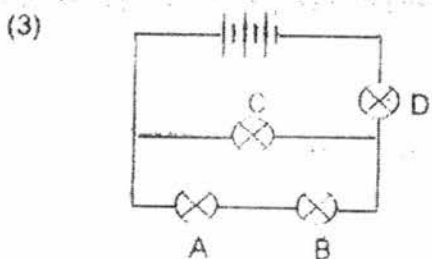
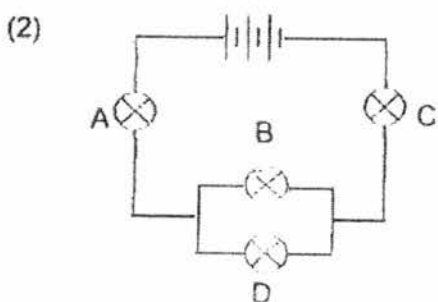
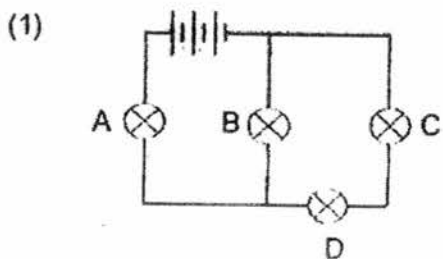

22. Sam wants to magnetise an iron rod using the following 'stroke' methods. The arrows (--->) show the movement of the magnets.

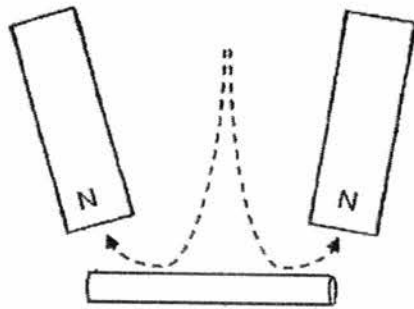

Method A

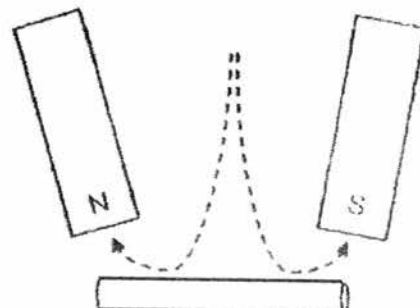

Method B

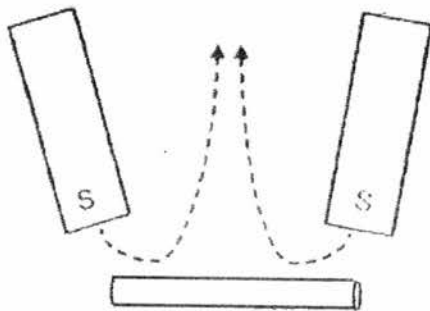

Method C

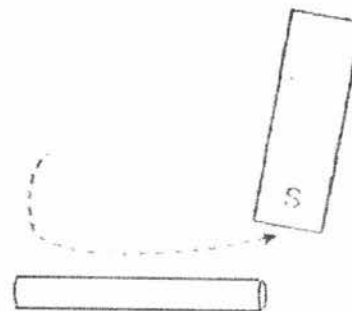

Method D

Which of the above is/are the correct 'stroke' method(s) that will magnetise the iron rod?

- (1) C only
- (2) D only
- (3) A and C only
- (4) B and D only



23. Nurul installed an electrical system in her room as shown below.

X and Y are made of steel and are in contact with one another.  
X is fixed but Y attached to a steel rod that can move sideways.  
Z is an Iron rod placed inside a coil of wire.

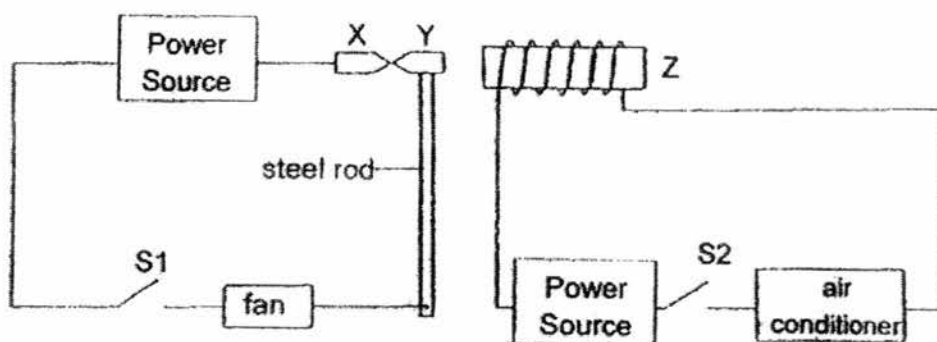

What is the purpose of installing such an electrical system?

- (1) When the air conditioner is turned off, more electricity flows through the fan.
- (2) This system increases the amount of electricity flowing through the air conditioner.
- (3) This system prevents the fan and air conditioner from being turned on at the same time.
- (4) When both S1 and S2 are closed, this system allows the fan and the air conditioner to be turned on at the same time.

24. Mr Lee was looking at three different types of floor tiles. He conducted an experiment to decide which floor tile to use for his bathroom. He leaned each tile on a block to make a ramp. He then dripped a drop of coloured water from a marked line at the top of the ramp and recorded the time taken for the drop of water to reach the bottom of the ramp. The set-up and the data recorded are shown below.

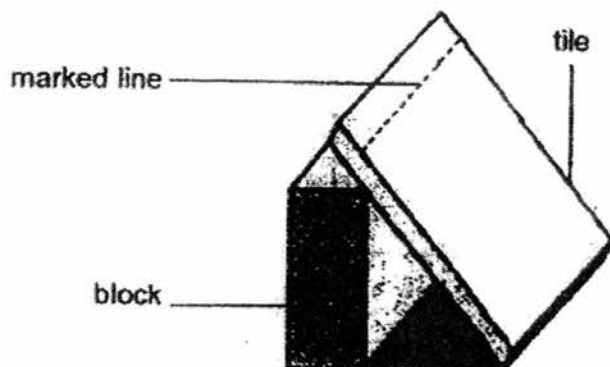

Tile	Time taken for water to reach the bottom of the ramp (s)
W	3.1
X	2.5
Y	4.3

What was the aim of Mr Lee's experiment?

- (1) To find out which tile shows the most friction between its surface and water.
- (2) To find out which tile transfers the most kinetic energy to the water.
- (3) To find out which tile can absorb the most amount of water.
- (4) To find out which tile has the greatest potential energy.

25. Chee Loong hung a weight on a spring as shown below.

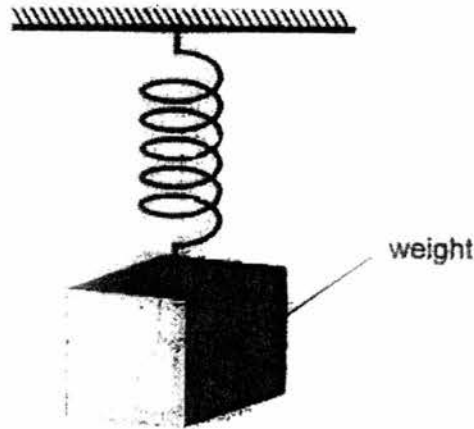

He slowly added more weights to the spring. Which one of the following graphs shows how the number of weights affects the pulling force acting on the spring only?

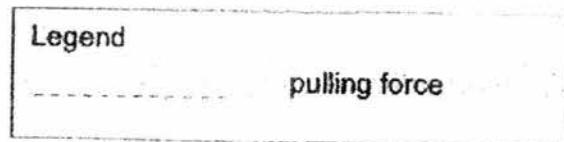
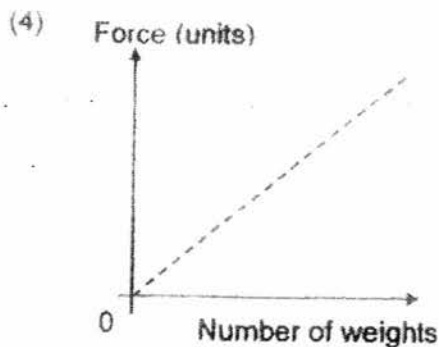
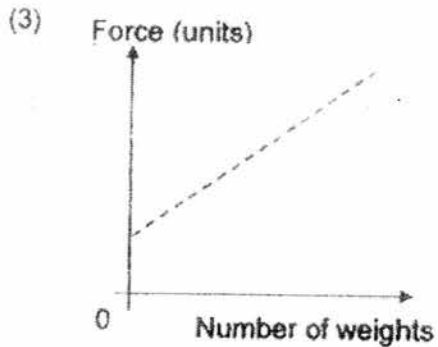
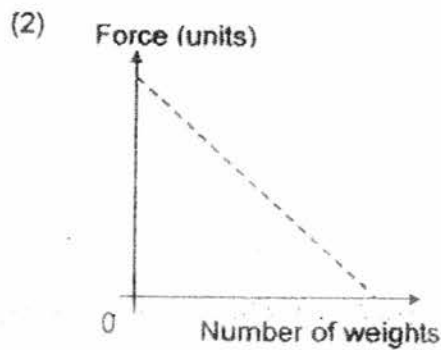
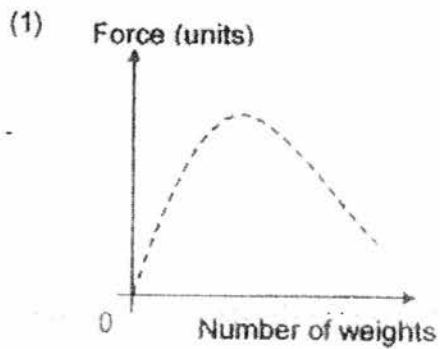

26. Muthu hung four magnets, P, Q, R and S, above a tray of identical iron pins. His observation is shown below.

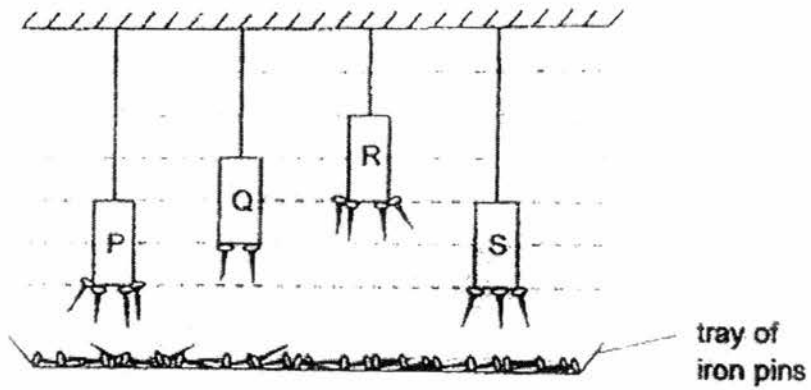

Which of the following conclusions is correct?

	Greatest magnetic strength	Least magnetic strength
(1)	R	Q
(2)	R	cannot be concluded
(3)	P	Q
(4)	P	cannot be concluded

27. Nicole conducted an experiment to investigate the melting of ice in hot tea. Equal amounts of tea were poured into containers A, B and C. The same volume of ice was then added into each container. After five minutes, the temperatures of the tea were recorded.

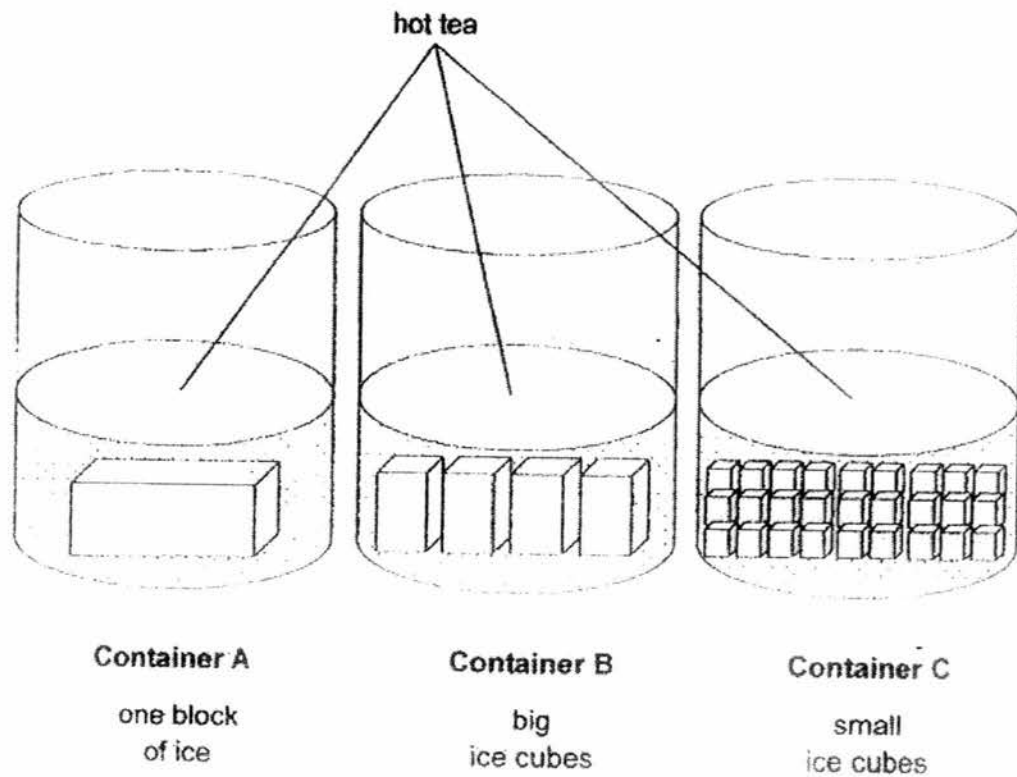

After five minutes, some ice can still be seen in all of the containers. Arrange the containers, A, B and C, in ascending order of the temperatures of the tea in them after five minutes.

- (1) A, B, C
- (2) C, B, A
- (3) B, A, C
- (4) C, A, B

28. The diagram below shows a ball being released from a stationary position at point W. The ball rolled along the track through points X and Y before it was stopped by a wooden block and came to a stop at point Z.

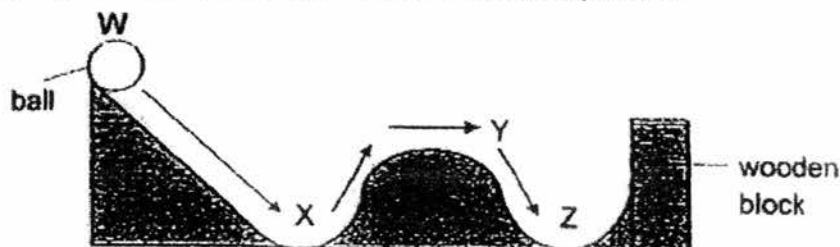

Which one of the following is correct?

	Kinetic Energy			Gravitational Potential Energy		
	From W to X	From X to Y	From Y to Z	From W to X	From X to Y	From Y to Z
(1)	increase	decrease	decrease	increase	decrease	decrease
(2)	decrease	decrease	increase	decrease	decrease	increase
(3)	decrease	increase	increase	increase	increase	increase
(4)	increase	decrease	increase	decrease	increase	decrease

29. The experiment below is carried out in a dark room. Sheets A, B, C, and D are arranged in a straight line.

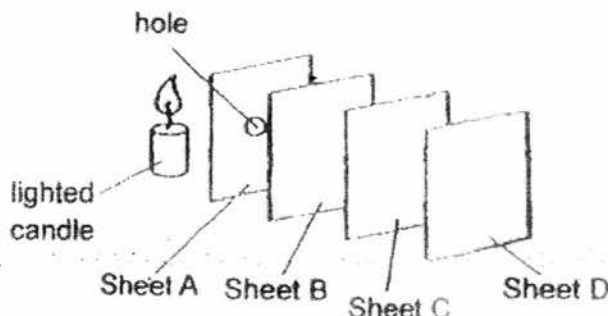

The properties of sheets A, B, C and D are shown in the table below.

Allows light to pass through	Does not allow light to pass through
B, D	A, C

A bright spot of light can be seen on one sheet only. Which sheet is that?

- (1) A  
 (2) B  
 (3) C  
 (4) D

30. The picture below shows a wooden object.

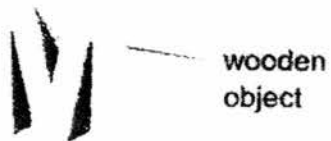

Which of the following shadows could be cast by the object?



- (1) A and D only
- (2) B and C only
- (3) A, B and C only
- (4) A, B, C and D

END OF SECTION A



# RED SWASTIKA SCHOOL

## 2016 PRELIMINARY EXAMINATION SCIENCE PRIMARY 6

Name : \_\_\_\_\_ ( )

Class : Primary 6/ \_\_\_\_\_

Date : 29 August 2016

### BOOKLET B

14 Questions

40 Marks

In this booklet, you should have the following:

- Page 23 to Page 39
- Questions 31 to 44

### MARKS

	OBTAINED	POSSIBLE
BOOKLET A		60
BOOKLET B		<del>40</del> 39
TOTAL		<del>100</del> 99

Parent's Signature : \_\_\_\_\_



## SECTION B

Answer all the questions in the spaces provided.

31. Imran left two pieces of bread in two identical jars, A and B. Drops of water were added to the bread in jar B only. He covered the jars to make them airtight. The diagrams below show the results of the experiment after three days.

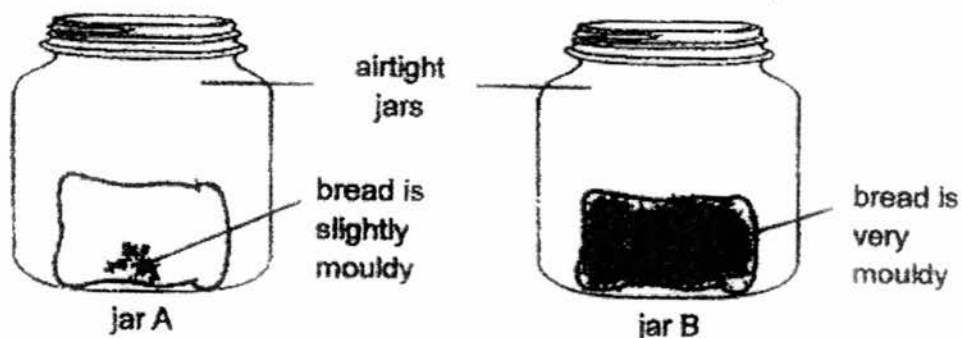

- (a) What is the purpose of keeping the bread in airtight jars? (1m)
- \_\_\_\_\_
- \_\_\_\_\_
- \_\_\_\_\_
- (b) A third piece of bread was toasted in the oven. After the bread had cooled down, it was put into another airtight jar. Three days later, it was observed that no mould grew on the bread. Give a reason for this observation. (1m)
- \_\_\_\_\_
- \_\_\_\_\_
- (c) Other than the condition that was being investigated in this experiment, state another condition that allows the bread to be kept fresh for a longer period of time. (1m)
- \_\_\_\_\_

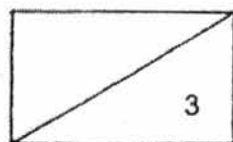

32. The pie chart below shows the dispersal methods of various plants on an island.

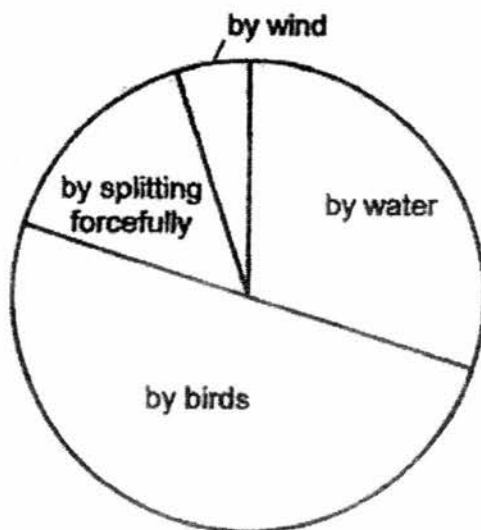

- (a) From the pie chart, describe one characteristic of the fruits that most of the plants on the island will have. Explain how this characteristic helps in the dispersal of the fruits. (1m)

---

---

- (b) Give a reason why the plant with dispersal method mention in part (a) has a better advantage over another plant that is dispersed by splitting its fruit forcefully. (1m)

---

---

- (c) Man decided to cut down many trees found on the island to supply wood for buildings. Some time after the trees were cut down, the population of birds decreased rapidly.

Give a reason why the population of birds decreased rapidly. (1m)

---

---

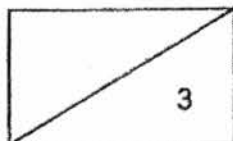

33. There are many air sacs in our lungs. Each air sac is surrounded by many tiny blood vessels. The diagram below shows how oxygen from the air sacs goes into one of the blood vessels.

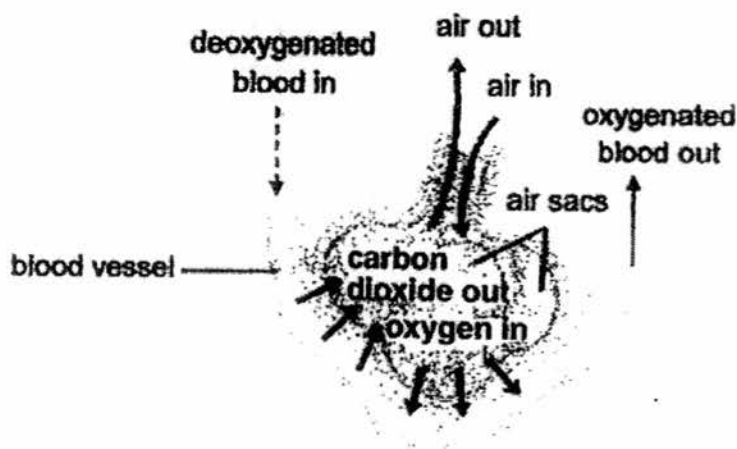

It is found that cigarette smoke damages the walls of air sacs and thus causes the number of air sacs to be reduced. The following table shows the number of breaths Mr X (a non-smoker) and Mr Y (a smoker) take at rest and the number of air sacs found in a sample part of their lungs.

	Number of breaths per minute at rest	Number of air sacs found in sample part of lungs
Mr X	12	15
Mr Y	20	3

- (a) Based on the table, what is the relationship between the number of air sacs in the lungs and the breathing rate at rest? (1m)

---



---

- (b) Using the information above, explain why Mr Y's breathing rate at rest is higher than Mr X's. (1m)

---



---

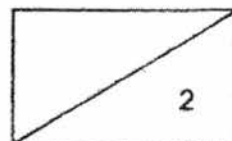

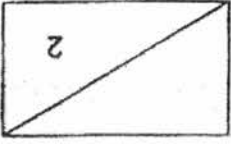

- (c) Mr X and Mr Y are friends who jog together. During a jog, the breathing rates of both Mr X and Mr Y increase. Explain why. (2m)

---

---

---

34. The graph below shows the change in temperature on Earth in the last few hundred years.

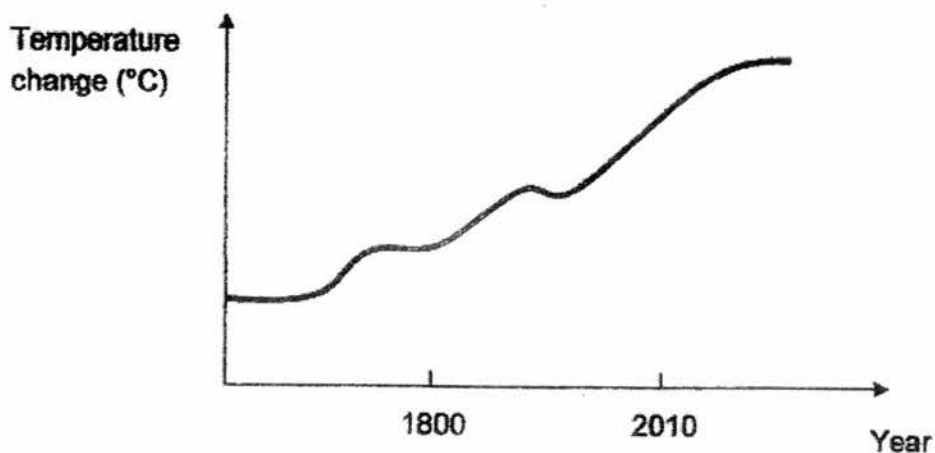

- (a) Name a greenhouse gas responsible for the change in temperature shown in the graph above. (1m)

---

- (b) How does the gas in (a) cause the change in temperature on Earth? (1m)

---

---

- (c) Explain how the loss of trees can lead to global warming. (1m)

---

---

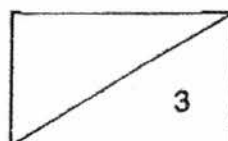

35. A food web comprises of five organisms, A, B, C, D and E. The table below shows the diet of organisms A, B, D and E.

Organism	Diet
A	B and D
B	C
D	C and E
E	C

(a)

In the space provided below, construct a food web based on the information given. (1m)

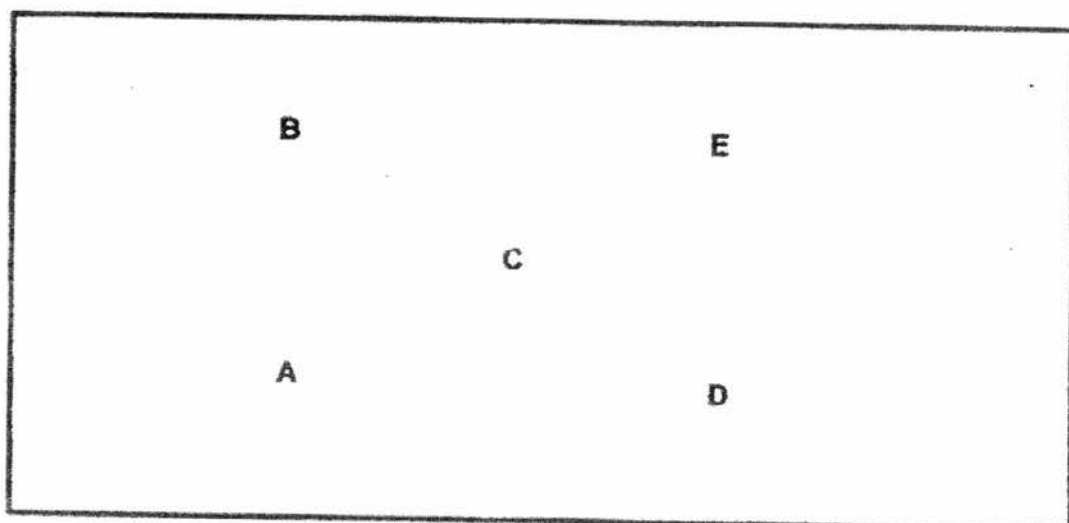

Organism B has the ability to change its skin colour to match the colour of organism C.

(b)

Based on the food web above, how does organism B's ability to change its colour help in its survival? (1m)

---

---

(c)

How does organism C benefit from the other organisms in the food web? (2m)

---

---

---

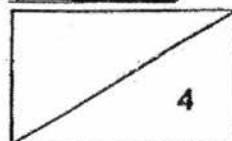

36. **Vultures are birds found in the warm region of the Earth. Unlike other birds, their heads are not covered with feathers. Vultures have sharp beaks and claws. They also have excellent senses of sight and smell. They normally feed on the rotting bodies of dead animals. They often fly and feed in large flocks.**

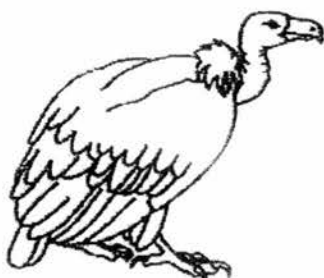

- (a) **A vulture does not have sweat glands and therefore it cannot perspire. Explain how the bald head of the vulture helps it to survive warm climate. (1m)**
- 
- 
- (b) **Besides the bald head, name another structural adaptation of the vulture based on the information given above. (0.5m)**
- 
- (c) **Explain how the structural adaptation mentioned in (b) helps the vulture to survive. (0.5m)**
- 
- 

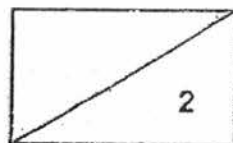

37. Gao Hang wanted to find out if the amount of sunlight would affect the rate of photosynthesis. He prepared two identical set-ups as shown below.

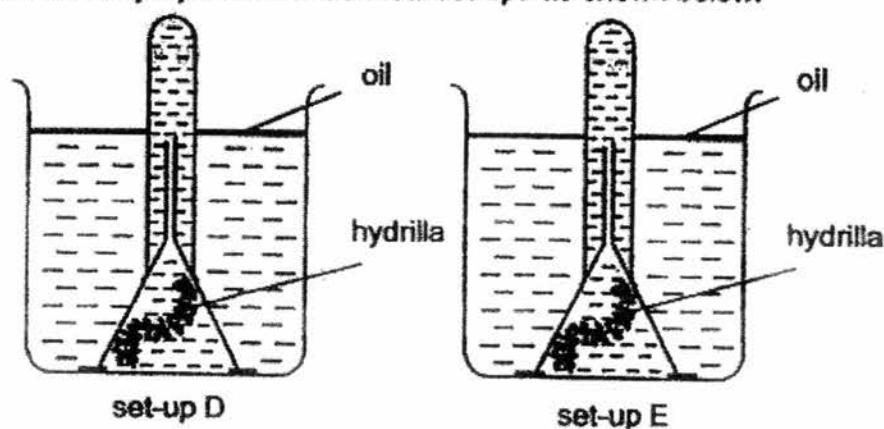

At the start of the experiment, Gao Hang filled each beaker with the same amount of water and each test tube was completely filled with water. He added a layer of oil to the water in the beaker. He placed the set-ups at two different locations.

The diagrams below show the observations of the two set-ups, D and E, after one day.

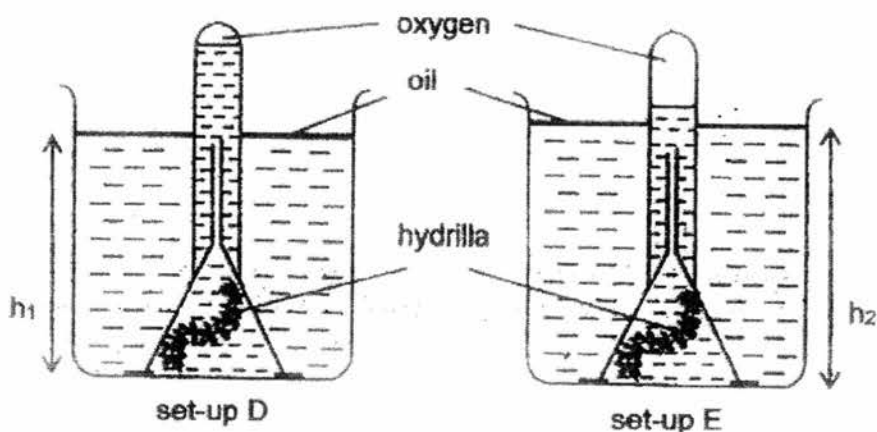

- (a) Which set-up was placed at a brighter location? Explain your answer. (1m)

---



---

- (b) Gao Hang noticed the water level outside the test-tube for set-up E,  $h_2$ , was higher than that in set-up D,  $h_1$ . Explain why  $h_2$  was higher than  $h_1$ . (1m)

---



---

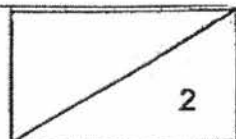



38. Eddie owns a shop that sells steamed buns. He keeps the steamed buns in boxes that look like the one below.



He observes that the steamed buns become soggy and the inside of the boxes become wet after he uses the boxes to store the steamed buns. He decides to make holes on the boxes as shown.

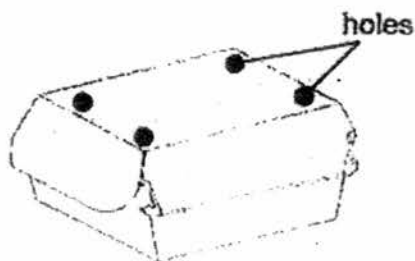

- (a) He realises that the steamed buns become less soggy after being kept in the boxes that have holes. Explain why. (2m)

---

---

---

- (b) Eddie wanted to find out which paper, X or Y, he should use for the box to keep the steamed buns. He conducted a fair experiment to find out how much water each type of paper could absorb and he recorded the results in the following table.

	Paper X	Paper Y
Amount of water absorbed	21.2 ml	13.2 ml

Given that both paper X and Y conducted heat similarly, which paper, X or Y, should Eddie use for the box so that the steamed buns would become less soggy after being kept in the box for some time? Explain your answer. (1m)

---

---

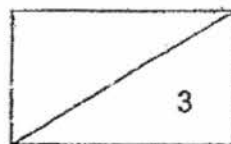

39. Recently, a drinks company changed the design of its cans, from design A to design B, as shown below.

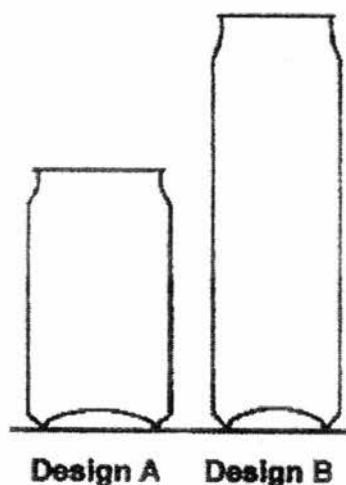

- (a) The same volume of drinks can be placed into both cans. What property of liquids is shown here? (1m)

---



---

Some details of the two designs are shown in the table below.

	Design A	Design B
<b>Height</b>	11.6 cm	14.8 cm
<b>Metal Type</b>	aluminium	aluminium
<b>Amount of metal used</b>	303.24 cm <sup>2</sup>	322.52 cm <sup>2</sup>
<b>Thickness of metal used</b>	0.02 cm	0.02 cm

- (b) Cans of Design A and B at room temperature, containing the same volume of drinks, were placed into a refrigerator at the same time. After five minutes, the drinks in the can of Design B had a lower temperature than the drinks in the can of Design A. Based on the data given, explain why. (1m)

---



---

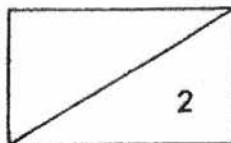

40. Lixin set up the circuit below.

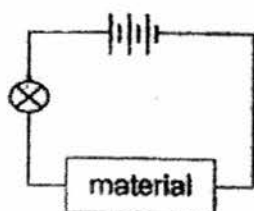

She used different materials in the circuit above and observed whether the bulb lit up. She recorded her results in the table below.

Material	Did the bulb light up?
W	Yes
X	Yes
Y	No
Z	Yes

- (a) What was the aim of her experiment? (1m)

---



---

- (b) Study the circuit diagram below.

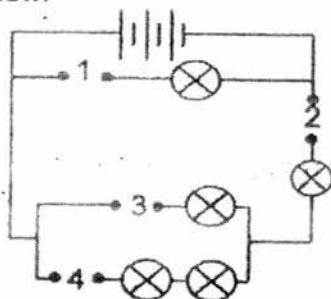

The numbers 1 to 4 represent the locations where materials W, X, Y and Z can be placed in the circuit. All the materials must be used and each material can only be used once. In the tables below, fill in where you can place materials W, X, Y and Z such that:

- (i) the most number of bulbs will light up. ( $\frac{1}{2}$ m)

Position	1	2	3	4
Material				

- (ii) the least number of bulbs will light up. ( $\frac{1}{2}$ m)

Position	1	2	3	4
Material				

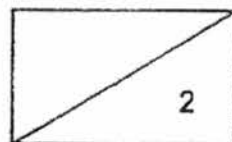

Lixin wanted to find out whether the number of bulbs in a circuit would affect the brightness of bulbs M and N. She set up the following circuits to investigate.

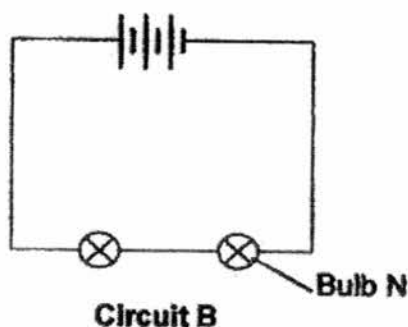
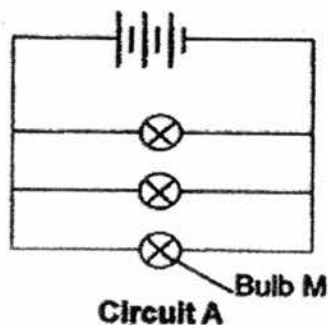

- (c) Do you think Lixin would be able to achieve her aim from the above set-ups? Explain your answer. (1m)

---



---



---

- (d) Lixin set up two circuits, C and D. She increased the number of bulbs in each circuit and observed the brightness of the bulbs. She recorded her observation in the graphs below.

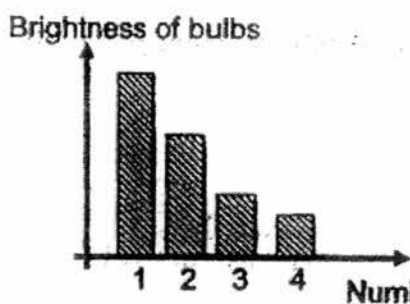

**Circuit C**

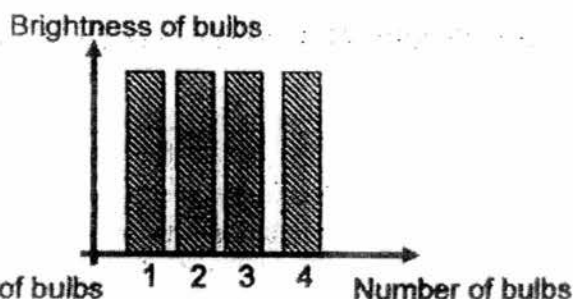

**Circuit D**

Based on the graphs above, what is the arrangement of the bulbs in each of the circuits? (1m)

(i) Circuit C: \_\_\_\_\_

(ii) Circuit D: \_\_\_\_\_

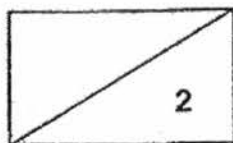

41. Norman set up an experiment as shown below. He pulled the load up the plank using a spring balance for different values of angle  $x$ .

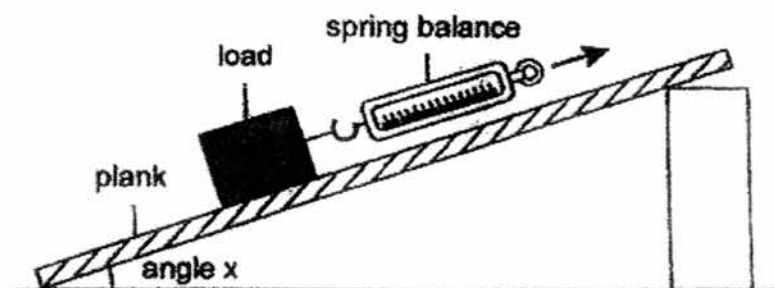

Norman plotted two lines, A and B, to represent the results of the experiment.

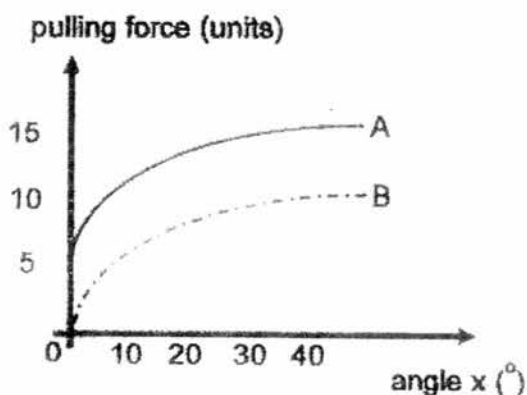

- (a) Which line, A or B, is the correct representation of the results of the experiment Norman conducted? Explain. (1m)

---



---

A worker wanted to push a heavy box up a plank from the ground to the back of a truck as shown below.

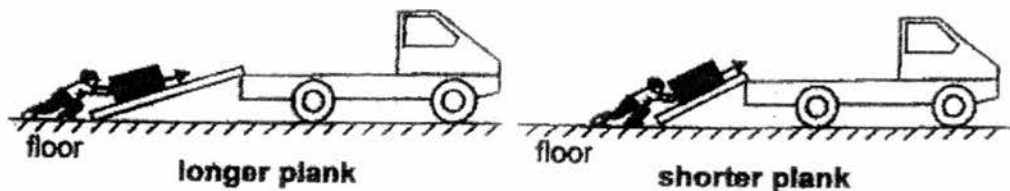

- (b) Give a reason why it is a disadvantage to use the shorter plank instead of the longer plank. (1m)

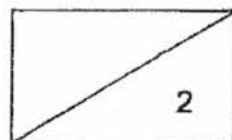

42. Five ring magnets, A, B, C, D and E, with equal magnetic strength were placed over a pencil vertically as shown below.

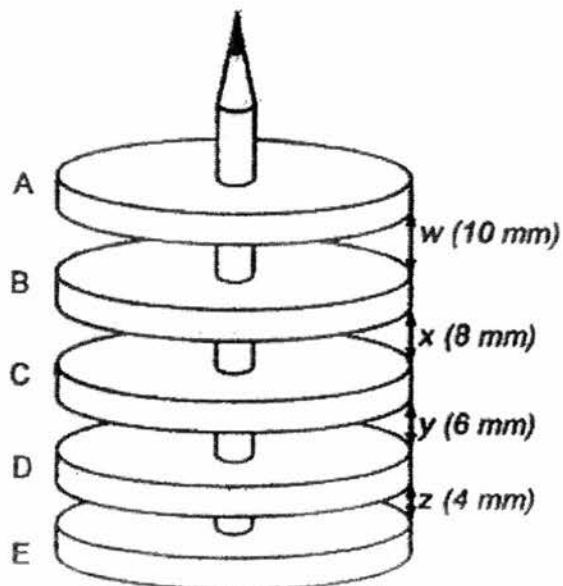

- (a) Why did the magnets float above one another? (1m)

---

---

- (b) In terms of forces, explain why distance  $w$  is greater than distance  $z$ . (1m)

---

---

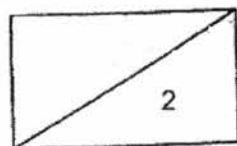

Some steel staple were mixed with other objects. Zhi Wei prepared the following set-up to separate the steel staple from the other objects. The bar magnets used in containers A and B were of the same magnetic strength.

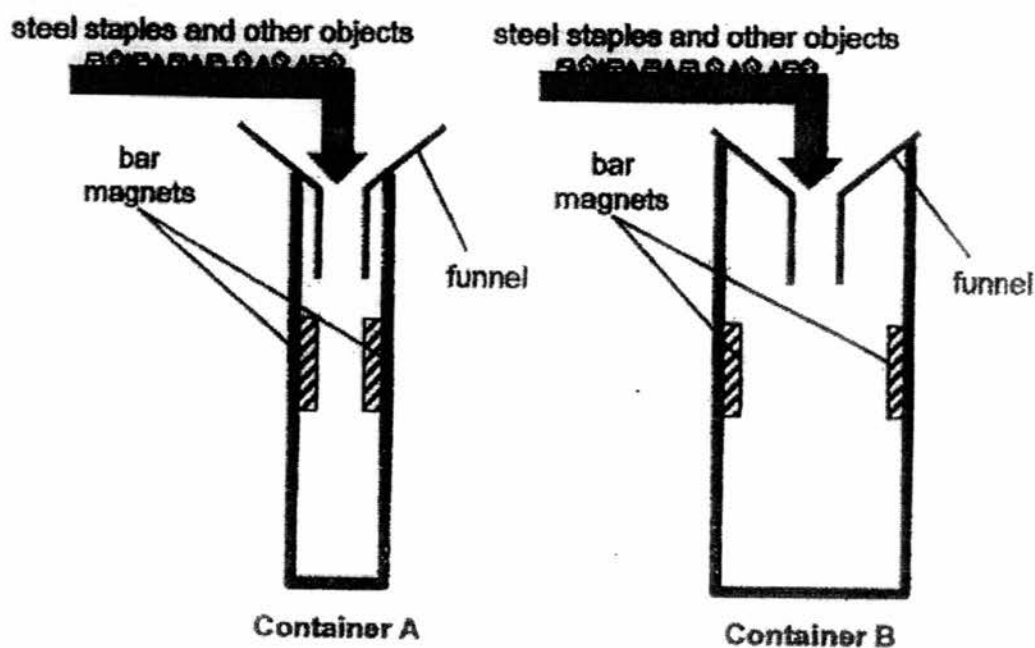

- (c) Which container, A or B, should Zhi Wei use to separate more steel staples from the other objects? Explain your answer. (1m)

---



---



---

- (d) What can Zhi Wei conclude about the property of the remaining items collected at the bottom of the container? Explain your answer. (1m)

---



---

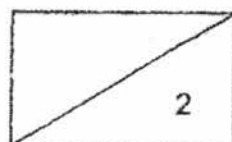

43. Megan wanted to find out if pockets of air would affect how fast cold water gains heat. She poured 150ml of cold water into two similar beakers. She used a plastic wrap that has airpockets to wrap around beaker P. She used another plastic wrap with no air pockets to wrap around beaker Q. Both set-up were placed next to each other in the Science laboratory.

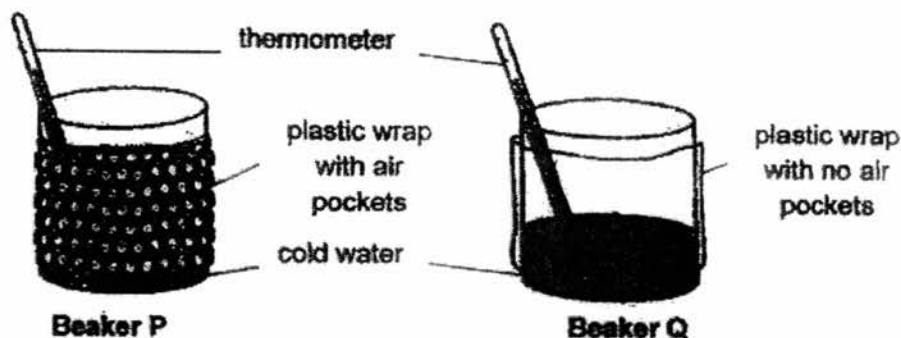

- (a) The water in beaker P had a lower temperature than the water in beaker Q after 5 minutes. Explain why. (1m)

---



---

- (b) Pizza is delivered in a closed cardboard box. A piece of ridged cardboard is placed at the bottom of the pizza as shown below.

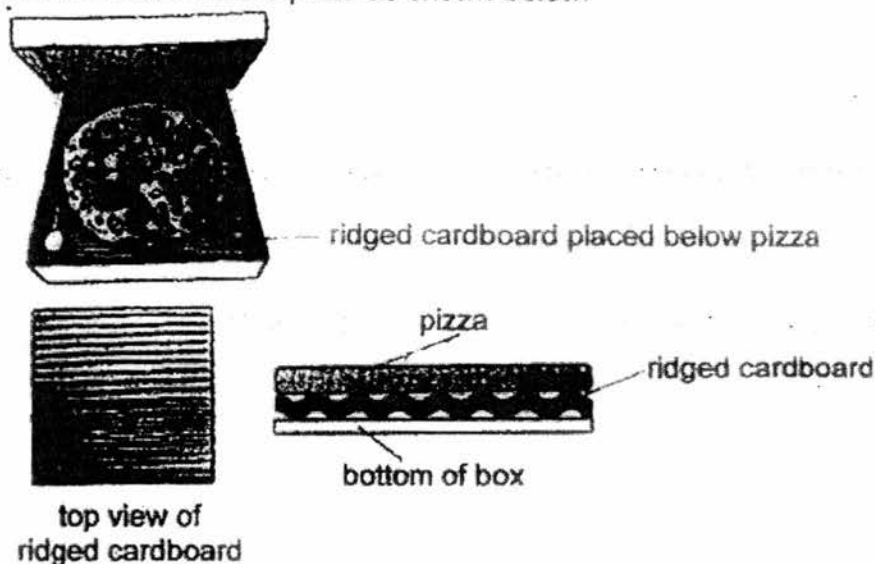

- Explain why a ridged cardboard is placed under the pizza to keep the pizza warm for a longer period of time. (1m)

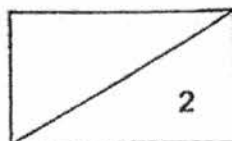



44. The diagram below shows how a hydro-electric power station is set up.

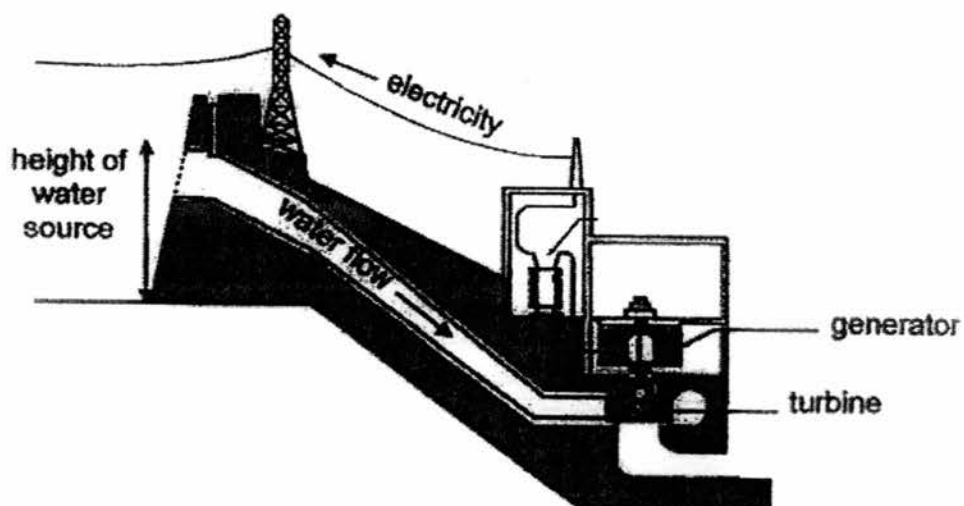

- (a) What is the relationship between the height of the water source and the electrical energy generated by the generator. (1m)

---

---

- (b) Fill in the boxes to show the energy changes. (1m)

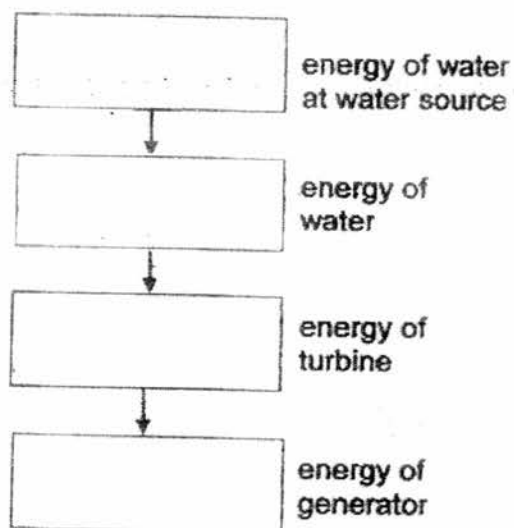

**END OF SECTION B**  
**PLEASE CHECK YOUR WORK**

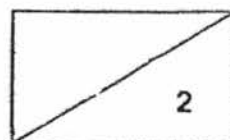



**PRELIMINARY EXAM PAPER 2016**

**SCHOOL : RED SWASTIKA PRIMARY SCHOOL**  
**SUBJECT : SCIENCE PRIMARY 6**  
**TERM : PRELIMINARY EXAMINATION 2016**

**PAPER 1**  
**BOOKLET A**

<b>Q1</b>	<b>Q2</b>	<b>Q3</b>	<b>Q4</b>	<b>Q5</b>	<b>Q6</b>	<b>Q7</b>	<b>Q8</b>	<b>Q9</b>	<b>Q10</b>
2	1	3	4	4	3	1	3	2	2
<b>Q11</b>	<b>Q12</b>	<b>Q13</b>	<b>Q14</b>	<b>Q15</b>	<b>Q16</b>	<b>Q17</b>	<b>Q18</b>	<b>Q19</b>	<b>Q20</b>
2	4	1	4	3	1	1	2	4	3
<b>Q21</b>	<b>Q22</b>	<b>Q23</b>	<b>Q24</b>	<b>Q25</b>	<b>Q26</b>	<b>Q27</b>	<b>Q28</b>	<b>Q29</b>	<b>Q30</b>
4	4	3	1	3	2	2	4	3	3

**PRELIMINARY EXAM PAPER 2016**

**SCHOOL : RED SWASTIKA PRIMARY SCHOOL**  
**SUBJECT : SCIENCE PRIMARY 6**  
**TERM : PRELIMINARY EXAMINATION 2016**

**BOOKLET B**

**31a)** It is to ensure that no water vapour/ spores/ oxygen from the surroundings will enter the jars and no water vapour/ spores/ oxygen from the jars will escape.

**31b)** As the moisture in the bread was removed from the bread during the toasting/ heating, mould would not be able to grow.

**31c)** Low temperature/ No oxygen/ less oxygen/ No air/ Less air/ Kept at 0°C/ NO warmth/ Cold/ cooler temperature.

**32a)** Most of the fruits are sweet /fleshy have small seeds that can be eaten/ have seeds that cannot be digested The birds eat the fruits and disperse the seeds in their droppings when they fly to the other parts of the island.

OR

Most of the fruits have last-be structures/ stiff hair and would cling onto the feathers/body/legs of the birds and be dropped off somewhere else.

**32b)** The fruits seeds can be dispersed further away from their parent plants so there will be less overcrowding and competition for nutrients space/sunlight/water.

**32c)** Trees are the natural habitat of birds. They provide food/ place to build nests/ protection from predators/ shelter. Without the trees on the island, the birds have no food/ no or place to live/ no place to build nest /no protection from predators /no shelter.

**33a)** The fewer the( the number of air sacs, the higher/ faster the breathing rate at rest.

**33b)** Mr Y has fewer air sacs, so oxygen moves into his blood from his air sacs. Hence, he has to breathe faster/ his breathing rate has to be higher to take in more oxygen.

**33c)** When they jog, their body needs more energy, hence they have to breathe faster to take in more oxygen from the surrounding air

**34a)** Carbon dioxide

**34b)** The gas traps heat from the sun, thus increasing the temperature on Earth

**34c)** There will be less trees to remove/ take in carbon dioxide for photosynthesis, so there will be more carbon dioxide in the atmosphere to trap more heat from the Sun.

**Key concept: Food web: A eats B and D; B eats C; D eats C and E; E eats C**

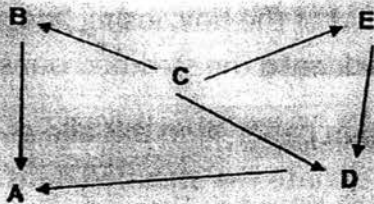

**35a)**

**35 (b)** Organism B can flag itself from organism A, its predator so that it will not be eaten by A.

**35c)** When the other organisms die their dead bodies will break down into simple substances which return into the soil and are taken in by organism C as nutrients for growth

OR The droppings of other organisms will act as fertilizer for Organism C.

OR Organisms produce carbon dioxide to help it photosynthesis.

OR The other organisms help to disperse the fruit of C further away from the parent plant to reduce overcrowding/ competition for sunlight/ space/ nutrients/water (any one condition)

**36a)** The bald head of the vulture helps it to lose its body heat to the surroundings more easily/ faster/ at a faster rate to keep cool.

OR The head of the vulture is bald so less body heat is trapped.

**36b)** It has a good sense of sight/ good sense of smell/ sharp beak/ sharp claws (any one)

**36c)** Its good sense of sight / smell helps it to detect dead/ rotting animals from a distance.

Its sharp beak /claws help(s) it to tear the flesh of the dead animals it is feeding on.

**37a)** Set-up E. There is more oxygen produced. With more light received, the rate of photosynthesis of the hydrilla is higher.

**37b)** There was more oxygen produced in set-up E, thus the oxygen occupied more space in the test tube, pushing/ displacing the water out of the test tube, causing  $h_2$  to be higher than  $h_1$ .

**38a)** The holes allow hot water vapour inside the box to escape hence less hot water vapour will come into contact with the cooler lid of the box, losing heat and condensing into tiny water droplets which will then fall back onto the steamed buns.

**38b)** Paper X. Paper x absorbed more water than paper Y, so this allows less water that was condensed on the lid of the box to fall back onto the steamed buns.

**39a)** Liquids

- have no definite shape
- take the shape of their containers
- have definite volume

**39b)** Design B has a larger surface area / more metal, therefore the drinks lost heat faster to its surroundings and cooled down faster.

**40a)** To find out if the material is a conductor /an insulator of electricity.

**40b) i)** As long as "Y" is placed in "1' or 3", that would result in 4 bulbs lighting up  
**ii)** As long as Y is placed in 2, that would result in 1 bulb lighting up

**40c)** No. Her investigation not fair. She has changed two variables: the arrangement of the bulbs and the number of bulbs, hence the results, the brightness of the bulb is affected.

**40d)** Circuit C: series

Circuit D: parallel

**41a)** Line A. When angle  $x$  is  $0^\circ$ , force is still required to pull the load on the plank to overcome the gravitational force or frictional force between the plank and the load.

**41b)** The inclination/ angle of the shorter plank is greater, hence of more force is required to push the box.

**42a)** The like poles of the magnets were facing one another, so they repelled one another.

**42b)** NIL

**42c)** Container A. The magnets are closer and has greater magnetism to attract more steel staples.

**42d)** The remaining items collected in the container were non- magnetic as they were not attracted to the bar magnets.

**43a)** The air in the air pockets is a poor conductor of heat, so heat gain from the warmer surroundings to the cold water in beaker P is slower than that for the water in beaker Q.

**43b)** The ridged cardboard reduces the surface area of pizza in contact with the cupboard, thus, slowing down heat loss from the pizza to the cupboard.

**44a)** As the height of the water source increases/decreases, the electrical energy generated by the generator increases/decreases.

**44b)** gravitational energy of water

↓  
kinetic energy of water

↓  
kinetic energy of turbine

↓  
electrical energy of generator

