



新加坡福建会馆属下五校小六统一考试

道南·爱同·崇福·南侨·光华

SINGAPORE HOKKIEN HUAY KUAN

5-SCHOOL COMBINED PRIMARY 6 PRELIMINARY EXAMINATION

TAO NAN · AI TONG · CHONGFU · NAN CHIAU · KONG HWA

2007

科学 SCIENCE

BOOKLET A

Total Time For Booklets A and B: 1 hour 45 minutes

### INSTRUCTIONS TO CANDIDATES

- ✓ Do not open this booklet until you are told to do so.
- ✓ Follow all instructions carefully.
- ✓ Answer all questions.

This booklet consists of 25 printed and 3 blank pages.

School : \_\_\_\_\_

Name : \_\_\_\_\_ ( )

Class : \_\_\_\_\_

Date : 30 August 2007

TOTAL	60
-------	----

**Section A (30 x 2 marks)**

For each question from 1 to 30, four options are given. One of them is the correct answer. Make your choice (1, 2, 3 or 4). Shade the correct oval (1, 2, 3 or 4) on the Optical Answer Sheet.

1. John fed 100 grams of maize and 100 grams of meat to 4 different animals. After one hour, he measured the amount of food left and recorded the results of his investigation in the table below.

Animals	Maize left (g)	Meat left (g)
A	100	0
B	80	50
C	100	50
D	0	100

Which animal(s) in John's investigation is likely to be an omnivore?

- (1) A only
- (2) B only
- (3) B and C only
- (4) A and D only

2.

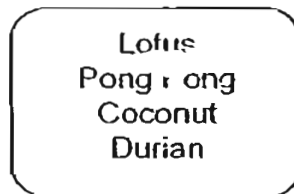

Which of the following characteristics can be used to classify the plants above into two groups?

- A: Flowering and non-flowering
- ~~B~~: Edible and non-edible
- C: Grow in water and grow on land
- D: Dispersed by water and dispersed by wind

- ~~(1)~~ A and B only
- ~~(2)~~ A and C only
- ~~(3)~~ B and C only
- ~~(4)~~ C and D only

3. Three similar pots of plants, P, Q and R, of the same mass are used in the experiment shown below. They are placed in an airy and sunny place. Each pot is given 300ml of water.



Plant P



Plant Q



Plant R

Which of the following set-ups is most likely to be correct after a day?

Setup A

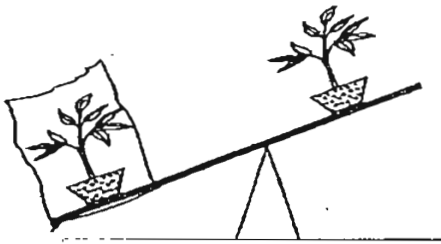

Setup B

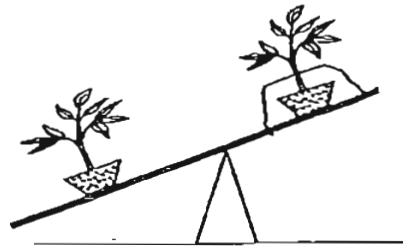

Setup C

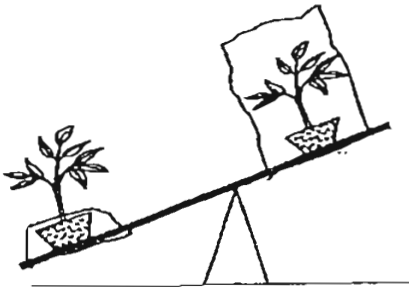

Setup D

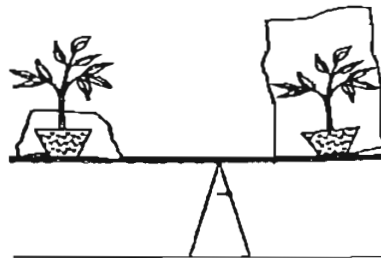

- (1) Setup A
- (2) Setup B
- (3) Setup C
- (4) Setup D

4. The diagrams show the life cycle of 2 insects.

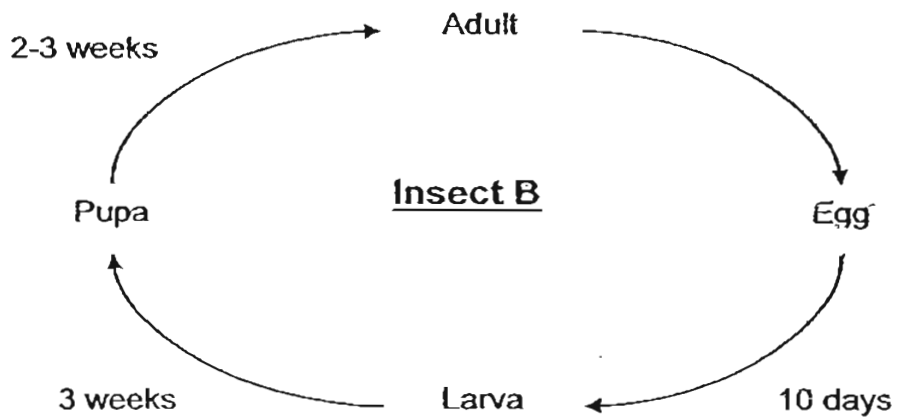
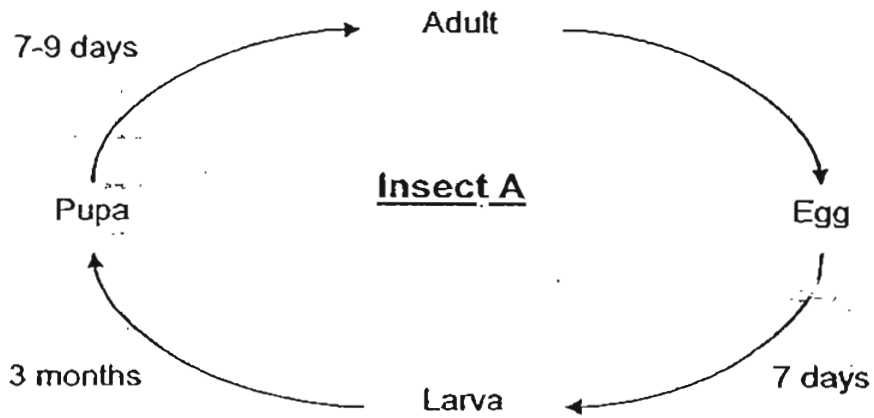

The diagrams **cannot** be used to compare \_\_\_\_\_.

- (1) the lifespan of the 2 insects
- (2) how the insects reproduce
- (3) the length of time it takes the eggs to hatch
- (4) the number of stages in the life cycle

5. A pupil germinated some seeds and recorded his observations in a table as shown below:

OBSERVATION	DAY
Seed becomes swollen	2
Seed coat breaks	5
Root appears	7
<del>Shoot starts to appear</del>	10
Shriveled seed leaves drop off	17

On which day will the seedling most probably be able to photosynthesize?

- (1) 5
- (2) 7
- (3) 10
- (4) 15

6. Study the classification below.

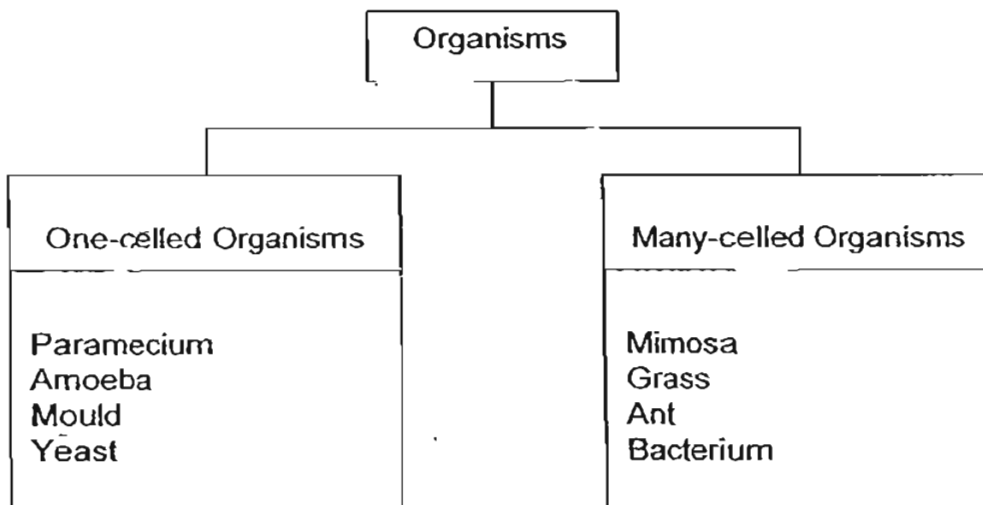

Which of the following organisms have been classified incorrectly?

- (1) Yeast and Mimosa
- (2) Amoeba and Grass
- (3) Mould and Bacterium
- (4) Paramecium and Ant

7. The table below shows four plants and their reproductive plant parts. Which plant is not matched correctly with its reproductive parts?

	Plants	Plant parts
A	Banana	Sucker
B	Hibiscus	Leaf
C	Bird's nest fern	Spore
D	Water chestnut	Underground Stem

- (1) A  
 (2) B  
 (3) C  
 (4) D

8. The table below shows how two animals are classified.

With Hair			
With wings		Without wings	
Lay eggs	Do not lay eggs	Lay eggs	Do not lay Eggs
	R	S	

Which of the following are differences between animals, R and S, according to the way they are classified in the table above?

- A. R is a mammal but S is not.  
 B. R gives birth but S does not.  
 C. R has wings but S does not.  
 D. S cannot fly while R can.

- (1) A only  
 (2) B only  
 (3) A and D only  
 (4) B and C only

9. The food web shows the food relationship between animals in a forest.

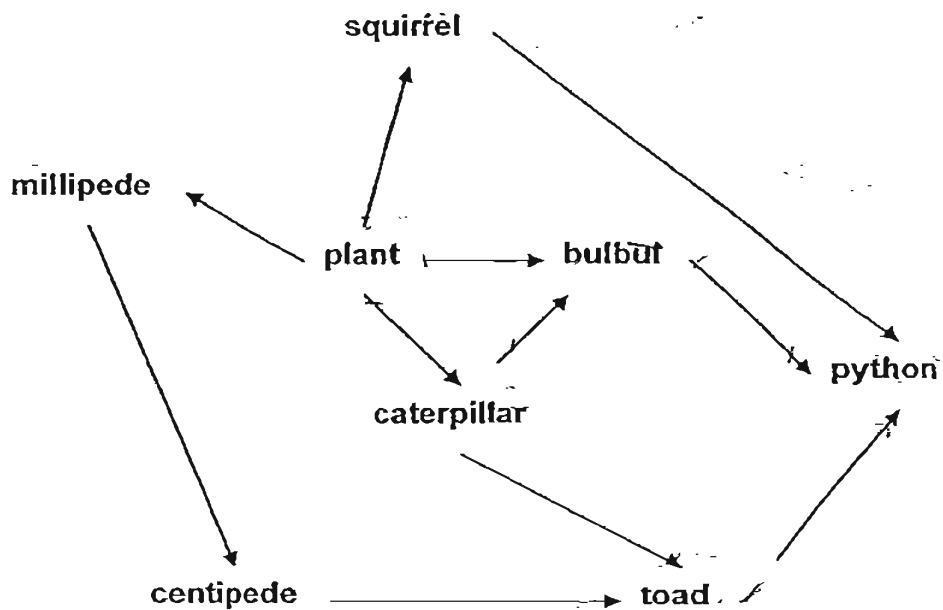

How many organisms are predators as well as prey?

- (1) 2
- (2) 3
- (3) 4
- (4) 5

10: The diagram below shows the human respiratory system.

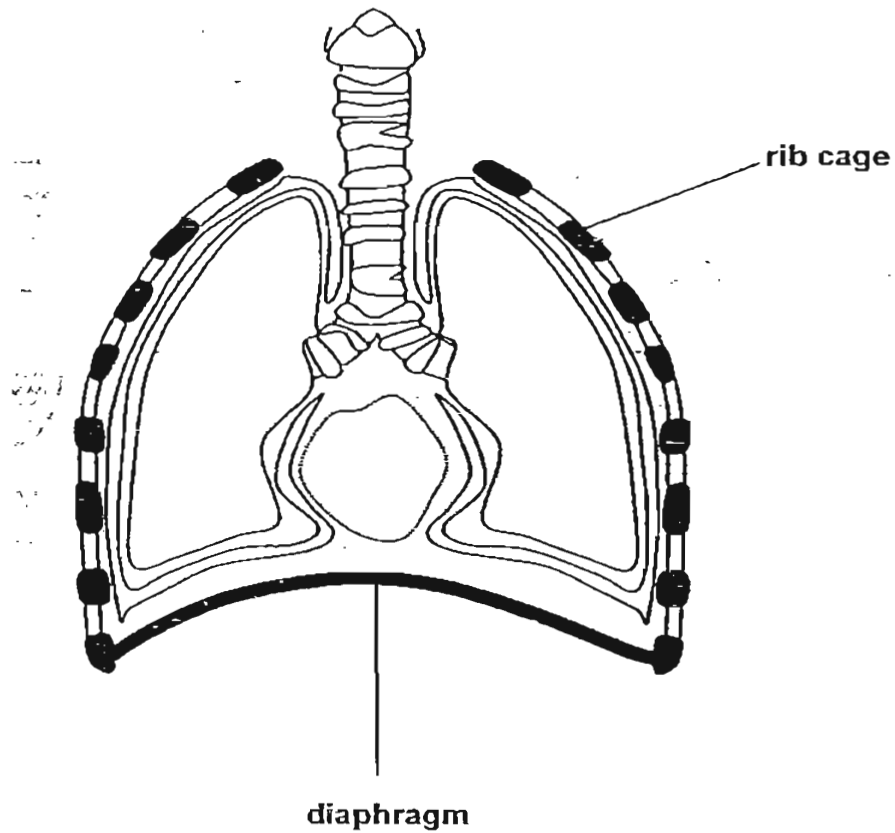

Which of the following shows the correct movements of the diaphragm and ribs during inhalation and exhalation?

	Diaphragm		Ribs	
	Inhalation	Exhalation	Inhalation	Exhalation
(1)	relaxes	contracts	down and inwards	up and outwards
(2)	relaxes	contracts	up and outwards	down and inwards
(3)	contracts	relaxes	down and inwards	up and outwards
(4)	contracts	relaxes	up and outwards	down and inwards



11. Our blood can be classified into four groups – A, B, AB and O.

The table below shows how the blood types of blood donors and recipients are matched.

Blood Type	Blood type of person donating blood			
	A	B	AB	O
Blood type of person receiving blood				
A	Yes	No	No	Yes
B	No	Yes	No	Yes
AB	Yes	Yes	Yes	Yes
O	No	No	No	Yes

Michael's family members have the following blood types:

Father - B  
Mother - A  
Brother - AB  
Sister - O  
Michael - B

If Michael needs a blood transfusion, who can he receive blood from?

- (1) His father only
- (2) His mother and brother only
- (3) His father and his sister only
- (4) His father, brother and sister only

12. Andrew set up an experiment to find out which conditions were most suitable for plants to live. The set-up consisted of five bell-jars containing a plant each. Each plant was given a different set of conditions. All the plants were identical and healthy at the start of the experiment.

The table below shows the conditions given to the five plants.

Bell-jar	A	B	C	D	E
Water	X	X	✓	X	✓
Oxygen	✓	✓	✓	✓	✓
Sunlight	X	✓	✓	✓	✓
Fertilizer	✓	X	X	✓	X
Carbon dioxide	✓	✓	X	✓	✓

✓ - present  
X - not present

Which 2 bell-jars of plants would be suitable to show that water is needed for the plant to make food?

- (1) A and C  
 (2) B and E  
 (3) C and D  
 (4) D and E
13. The pie chart below shows the proportion of five populations of organisms in a garden community. These five populations form a food chain.

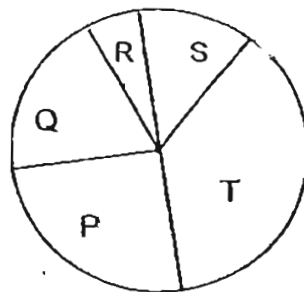

Which of the food chains below illustrates the relationship between these five organisms?

- (1)  $Q \rightarrow R \rightarrow S \rightarrow T \rightarrow P$   
 (2)  $R \rightarrow S \rightarrow Q \rightarrow P \rightarrow T$   
 (3)  $P \rightarrow T \rightarrow Q \rightarrow R \rightarrow S$   
 (4)  $T \rightarrow P \rightarrow Q \rightarrow S \rightarrow R$

14. Two plants crossed pollinated and produced a plant with the flower shown below.



Purple and White Flower

Which of the following pair(s) of flowers is/are likely to be from the parent plants?

	Colour of Parent Flowers	
	Male	Female
<input checked="" type="checkbox"/> A	Purple	White
<input checked="" type="checkbox"/> B	White	White
<input checked="" type="checkbox"/> C	Purple and white	Purple
<input checked="" type="checkbox"/> D	Purple	Purple

- (1) A only
- (2) D only
- (3) A and C only
- (4) B and D only

15. A classification chart is shown below.

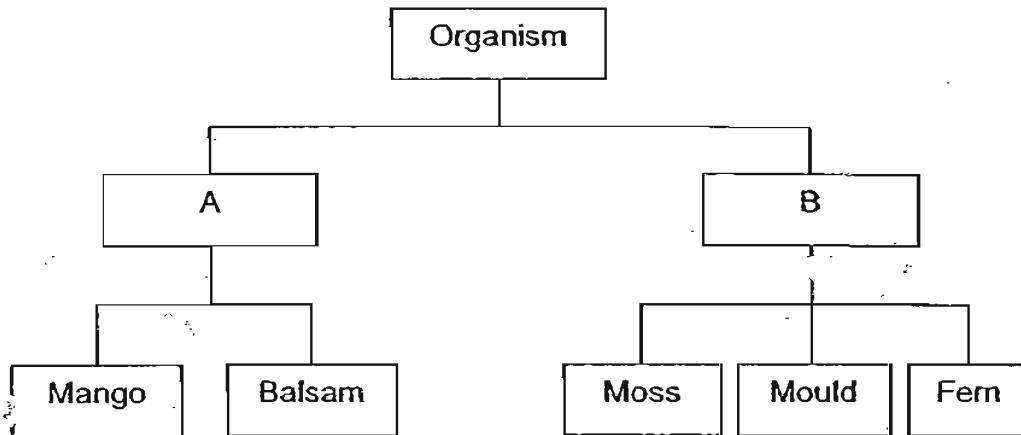

What could A & B be?

	A	B
(1)	Non-Flowering Plants	Flowering Plants
(2)	Able to Photosynthesize	Unable to Photosynthesize
(3)	Reproduce from Seeds	Reproduce from Spores
(4)	Insect Pollinated	Wind Pollinated

16. Some Science Club members observed a goldfish in a tank. They kept a record of the number of times the gill covers open and close. The graph below shows the results of their observation.

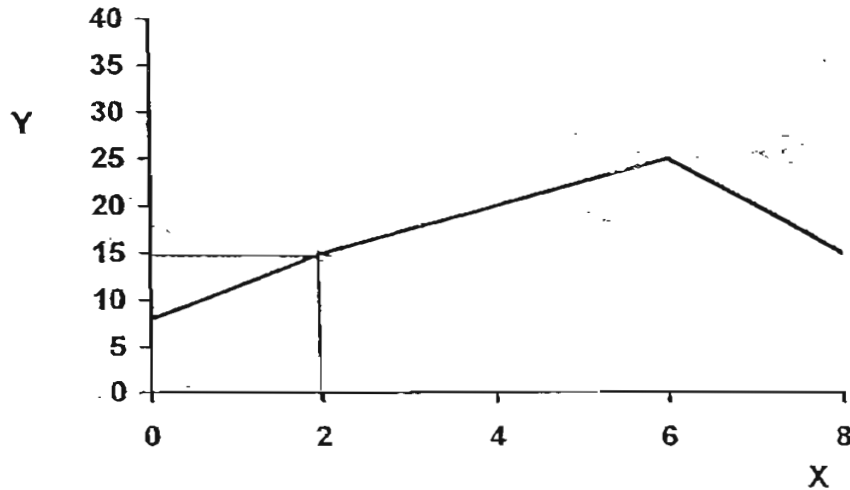

X: Number of days

Y: Number of times gill covers open and close in 30 seconds

What could the Science Club members have done at the end of the sixth day to cause the results shown in the graph above?

- (1) They put in another fish.
- (2) They provided the fish with food.
- (3) They added aquatic plants.
- (4) They moved the tank to another location.

17. George conducted an experiment to investigate the amount of light that can pass through three materials of the same thickness. The materials he used were frosted glass, clear plastic sheet and styrofoam board. He shone a torch through the three materials. He used a light sensor to measure how much light has passed through each of them.

He drew a graph to show the amount of light recorded by the light sensor. Which of the following graphs is the correct one?

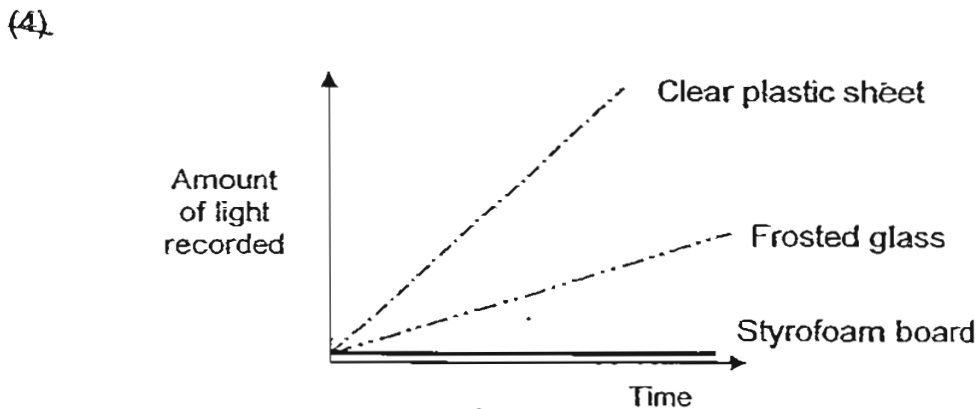
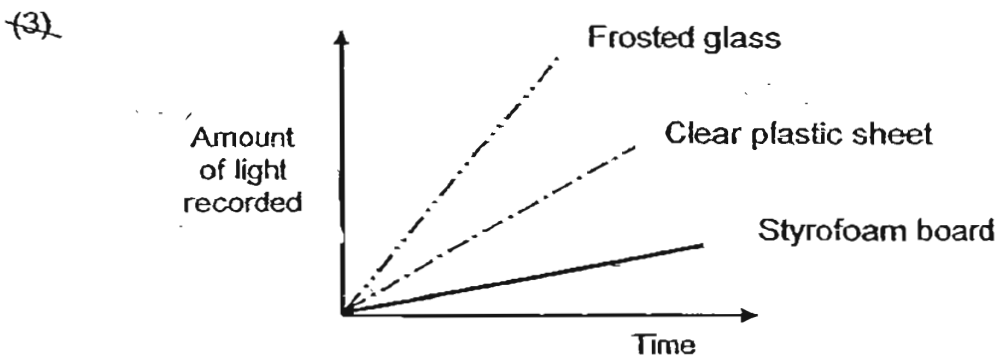
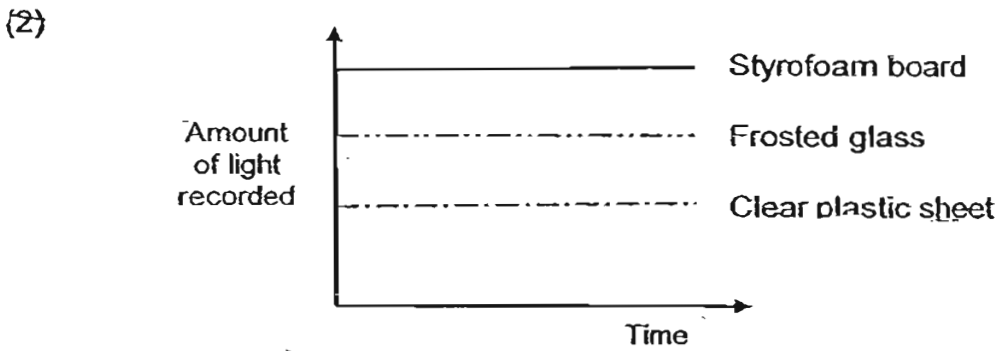
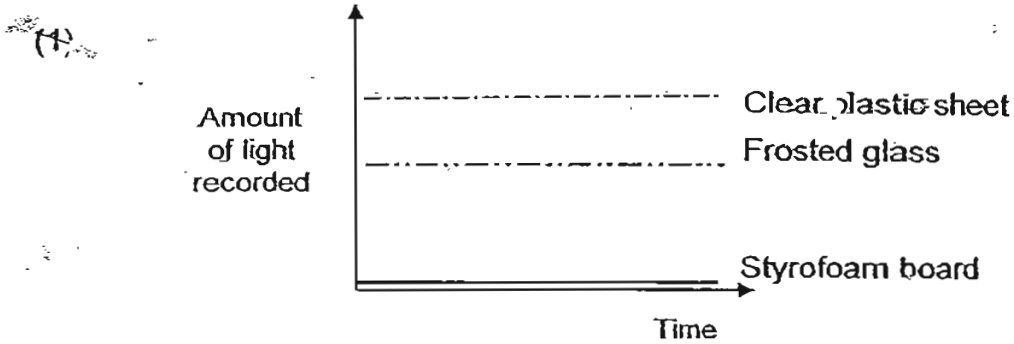

18. Five objects of the same size but different masses, are put into a tank of water. The diagram shows what happens when they are in the water. Study the diagram and answer the question below.

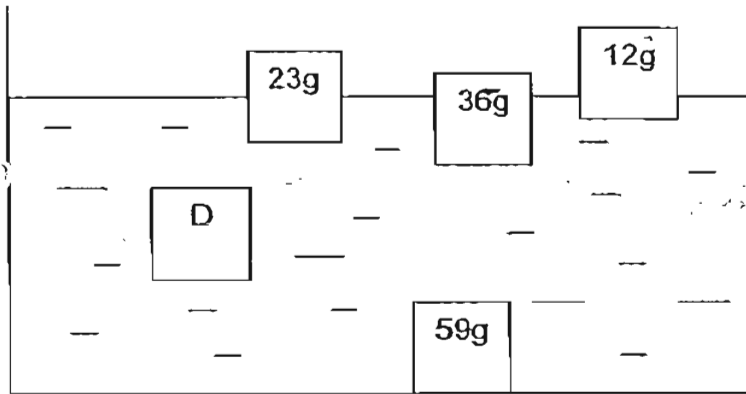

Which one of the following is the mass of object D?

- (1) 25g  
 (2) 32g  
 (3) 42g  
 (4) 60g
19. Keric wants to find out whether stirring makes salt dissolve faster in water. Besides using the same amount of salt, which of the following variables should he keep the same?
- A. Type of salt  
 B. Amount of water  
 C. Temperature of the water  
 D. Number of times the water was stirred
- (1) A and B only  
 (2) C and D only  
 (3) A, B and C only  
 (4) B, C and D only

20. Four identical beakers, A, B, C and D, were filled with the same volume of water. They were left in four places with different conditions for 10 hours as shown in the table below.

Containers	A	B	C	D
Conditions	Sunny Windy	Sunny Not windy	Cloudy Not windy	Cloudy Windy

Which one of the following graphs correctly shows the volume of the water left in A, B, C and D after 10 hours?

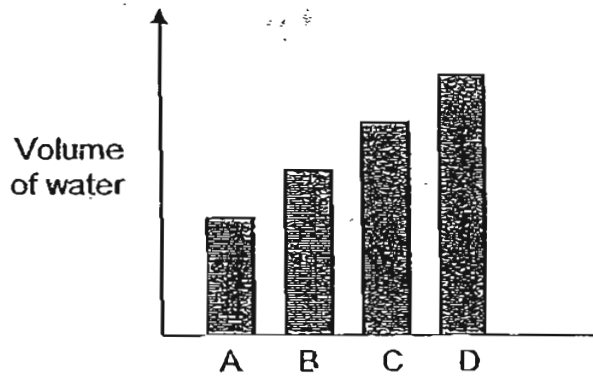

(1)

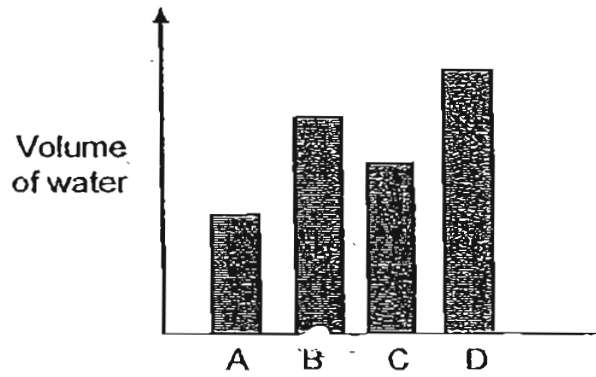

(2)

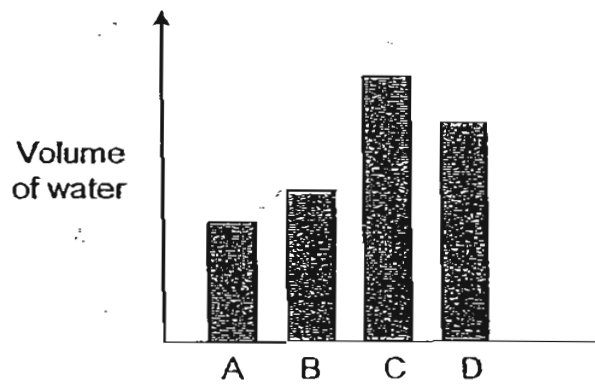

(3)

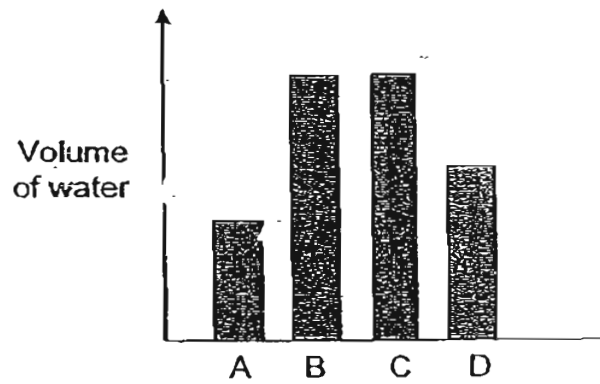

(4)



21. John carried out an experiment to determine the effects of objects of different masses on a spring. A line graph was plotted as shown below after the experiment.

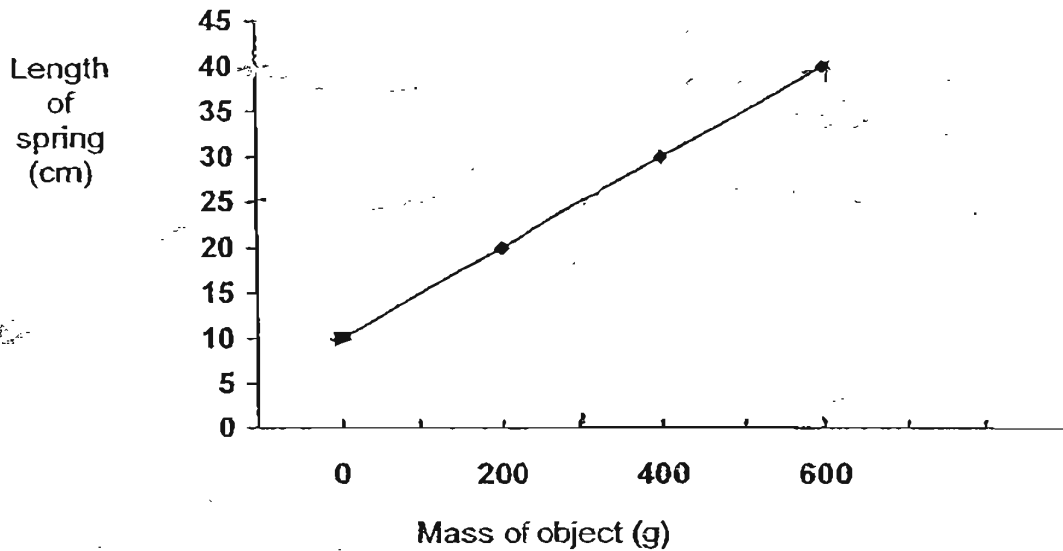

What can John conclude from the line graph above?

- A. The length of the spring increases proportionately.
- B. Doubling the mass will double the length of the spring.
- C. When a 600g object is hung on the spring, the length of the spring is 30cm.
- D. The extension of the spring is 15cm when a 300g object is hung on it.

- A only
- A and D only
- A, B and D only
- All of the above

22. The diagram below shows a water container filled with  $3000 \text{ cm}^3$  of water. The capacity of the container is  $8000 \text{ cm}^3$

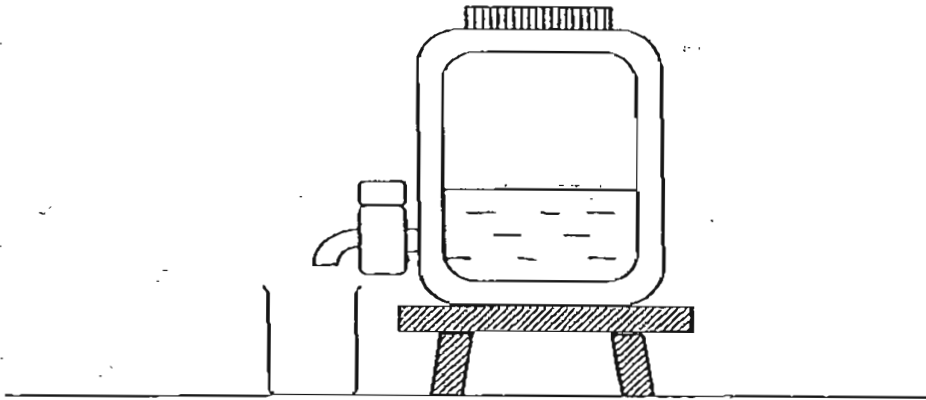

When the tap of the container is turned on and off,  $500 \text{ cm}^3$  of water is released into the beaker.

What is the final volume of the air in the container?

- (1)  $4500 \text{ cm}^3$
- (2)  $5000 \text{ cm}^3$
- (3)  $5500 \text{ cm}^3$
- (4)  $7500 \text{ cm}^3$

23. Aileen had three rods, P, Q and R, of unknown materials. She placed them in various positions, A, B and C, as shown in the circuit below.

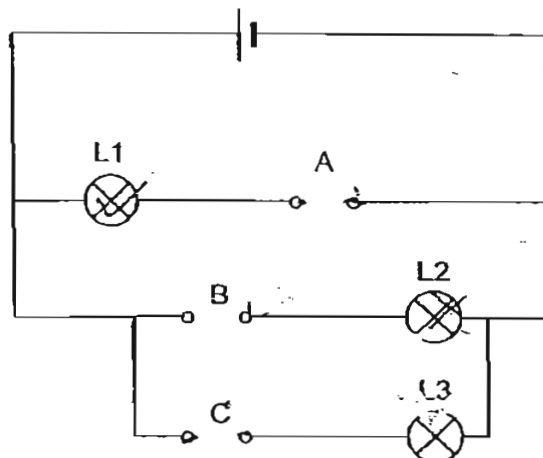

The results of the experiment were shown in the table below.

Position	A	B	C
Rod	P	Q	R
Lamp	L1	L2	L3
Bulb lights up?	No	Yes	Yes

She repeated the experiment by placing the rods at different positions as shown in the table below.

Position where rods were placed		
A	B	C
Q	P	R

Which one of the following would show the correct result?

	Lamp		
	L1	L2	L3
(1)	Yes	Yes	No
(2)	Yes	No	Yes
(3)	Yes	Yes	Yes
(4)	No	Yes	Yes

24. Janet was told to investigate if the arrangement of the bulbs in a circuit affects their brightness. She set up four circuits as shown in the diagrams below.

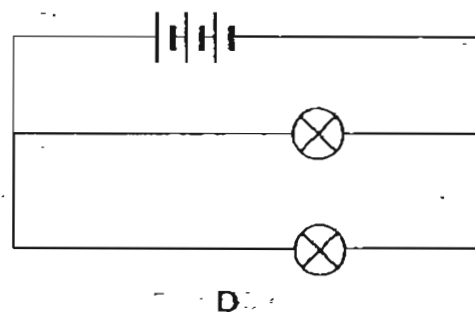
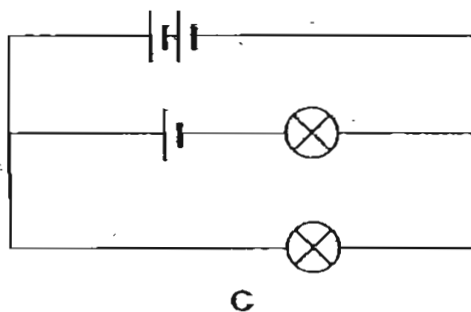
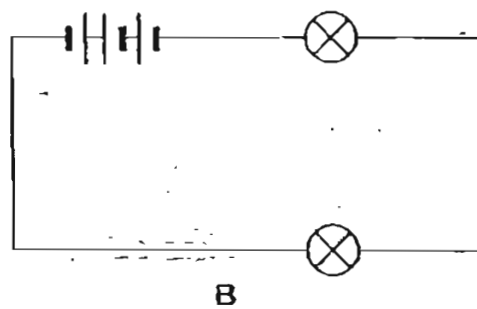
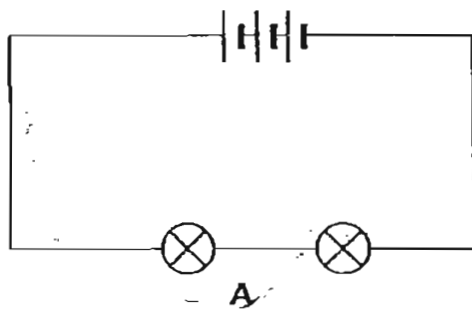

Which of the two circuits shown above should be used to ensure a fair test?

- (1) A and C
- (2) A and D
- (3) B and C
- (4) B and D

- 25: Janet carried out an investigation with 4 beakers of water. The volume of water in each beaker was recorded at the start and end of the investigation. The results are shown in the table below.

Beaker	Amount of water at the start of the investigation (ml)	Amount of water at the end of the investigation (ml)
A	70	24
B	60	30
C	50	40
D	40	25

What can you infer from the results shown in the table?

- (1) Beaker C has the biggest exposed surface area.  
 (2) Evaporation was the slowest in Beaker A.  
 (3) More water evaporated from Beaker B than Beaker D.  
 (4) The least amount of water evaporated from Beaker D.
26. The diagram below shows the position of the shadow cast by a stick at 4 different times during a day.

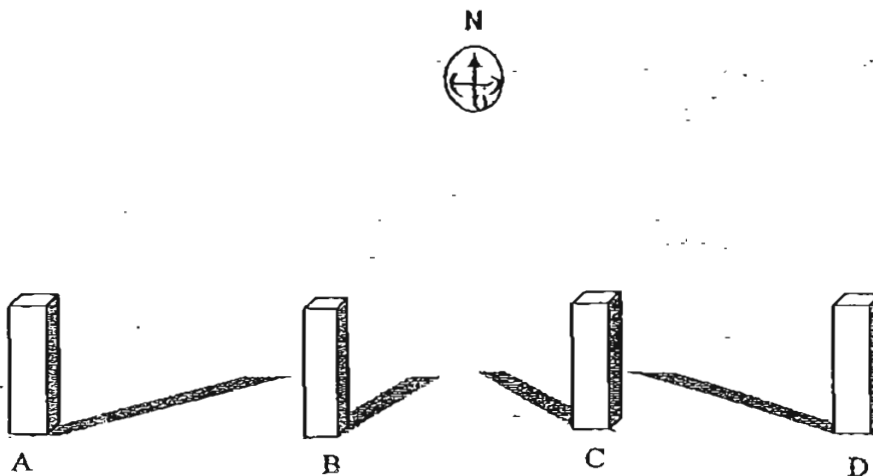

Which diagram shows a shadow cast at 6.00pm?

- (1) A  
 (2) B  
 (3) C  
 (4) D

27. Ming Li set up an experiment to find out the relationship between the height of a ramp and the distance travelled by a toy car.

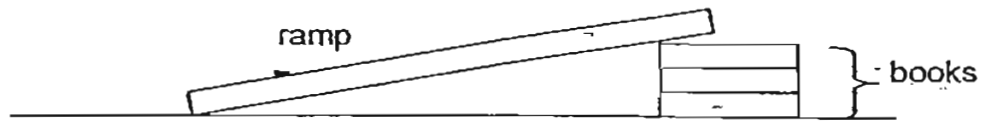

Which one of the following graphs shows the correct result of the experiment?

(1)



(2)

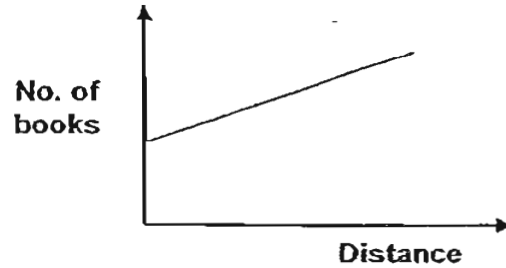

(3)

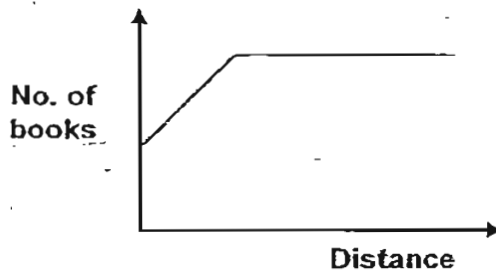

(4)

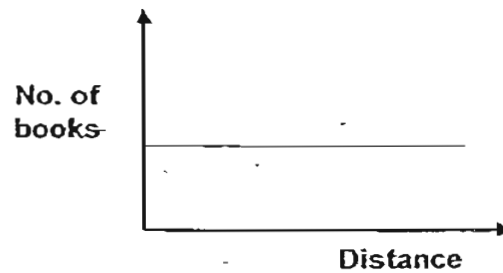

28. The flow chart below shows the properties of 4 different materials A, B, C and D.

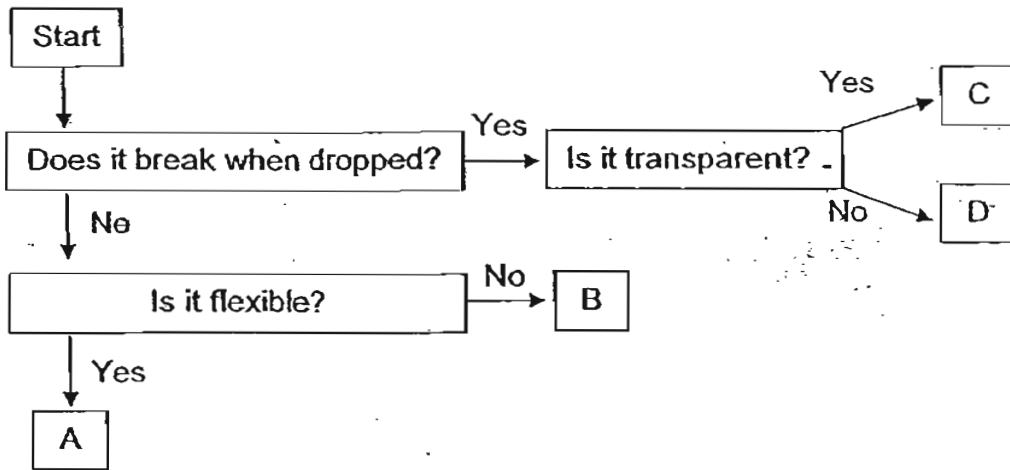

Which materials A, B, C or D are suitable for making the objects shown in the table below?

	A	B	C	D
(1)	Nylon socks	Wine glass	Clay figurine	Plastic spoon
(2)	Plastic spoon	Clay figurine	Nylon socks	Wine Glass
(3)	Nylon socks	Plastic spoon	Wine Glass	Clay figurine
(4)	Clay figurine	Wine glass	Plastic spoon	Nylon socks

29. The diagram below shows 3 objects X, Y and Z in the Solar System. The lines indicate the paths moved by Objects Y and Z.

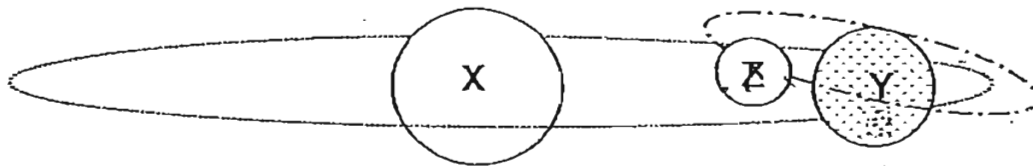

The following are descriptions of Objects X, Y and Z.

- X is a star.
- Y supports life.
- Z is a natural satellite of Y.

Which one of the following statements is incorrect?

- ~~(1)~~ The rotation of Y causes day and night.  
~~(2)~~ X ensures that the water cycle on Y continues.  
~~(3)~~ We can see Z because it reflects light from X.  
~~(4)~~ When Z revolves round Y, it causes the four seasons.



30. The diagram shows three gears, X, Y and Z.

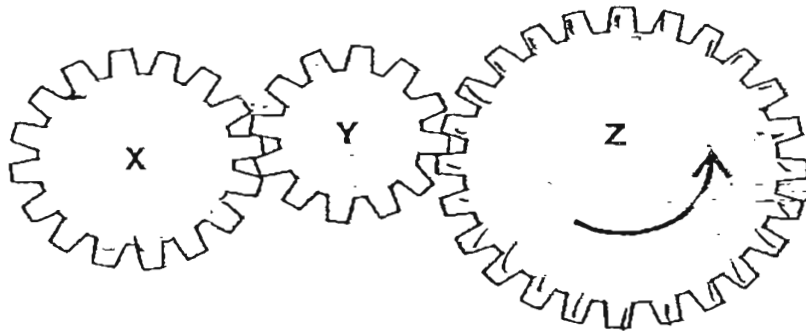

The number of teeth in each of the gears is shown in the table below.

Gear	Number of teeth
X	16
Y	12
Z	24

Which one of the following shows the correct number of turns for gears X, Y and Z?

	Gear X	Gear Y	Gear Z
(1)	32	24	<u>16</u>
(2)	24	32	16
(3)	16	12	24
(4)	12	16	24



新加坡福建会馆属下五校小六统一考试

道南·爱同·崇福·南侨·光华

SINGAPORE HOKKIEN HUAY KUAN

5-SCHOOL COMBINED PRIMARY 6 PRELIMINARY EXAMINATION

TAO NAN · AI TONG · CHONGFU · NAN CHIAU · KONG HWA

2007

科学 SCIENCE

BOOKLET B

Total Time For Booklets A and B: 1 hour 45 minutes

### INSTRUCTIONS TO CANDIDATES

- ✓ Do not open this booklet until you are told to do so.
- ✓ Follow all instructions carefully.
- ✓ Answer all questions.

This booklet consists of 17 printed and 3 blank pages.

School : \_\_\_\_\_

Name : \_\_\_\_\_ ( )

Class : \_\_\_\_\_

Date : 30 August 2007

TOTAL	40
-------	----

**Section B: 40 marks**

Read the questions carefully and write down your answers in the spaces provided.

31. The table gives us some information on 5 animals.

Animals	Life cycle	Habitat	Diet	Legs
Housefly	4 stages	Rubbish dump	Omnivore	6 legs
Grasshopper	3 stages	Field	Herbivore	6 legs
Rhinoceros beetle	4 stages	Tree	Herbivore	6 legs
Cockroach	3 stages	House	Omnivore	6 legs
Butterfly	4 stages	Garden	Herbivore	6 legs

Janet selected one characteristic and classified the animals into 2 groups as shown in the table below.

Janet's table:

Group A	Group B
Housefly	Grasshopper
Rhinoceros beetle	Cockroach
Butterfly	

Jill selected another characteristic for her classification as shown in the table below.

Jill's table:

Group A	Group B
Housefly	Grasshopper
Cockroach	Rhinoceros beetle
	Butterfly

(a) Based on the information given, what characteristics did Janet and Jill use to classify the animals? [1]

Janet: \_\_\_\_\_

Jill: \_\_\_\_\_

(b) Why are the other 2 characteristics given in the table not suitable for use to classify the animals? [2]

(i) \_\_\_\_\_

(ii) \_\_\_\_\_

32. The diagram shows the process of pollination that occurs in the life cycle of a flowering plant.

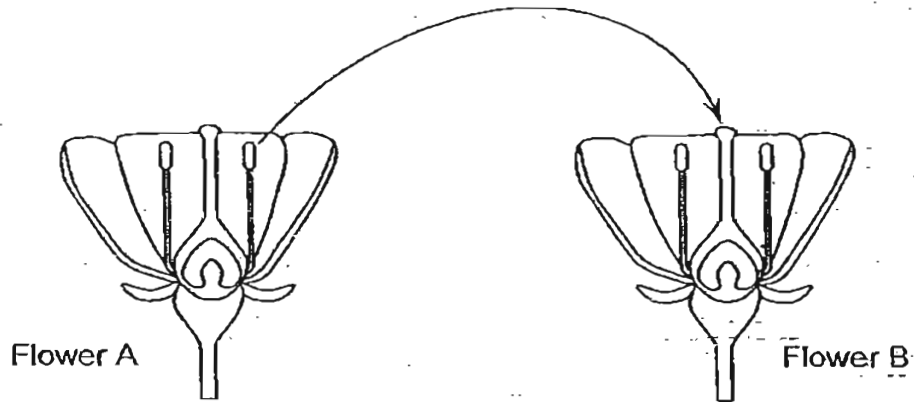

(a) Describe the process that is shown above. [1]

(b) State one observable change in the flower following this process. [1]

33. A substance has to pass through various parts of a plant cell before reaching the nucleus.

(a) Use the words given below to write the correct order in which the substance has to pass through. [1]

Cell membrane      Cytoplasm      Cell wall



(b) What is the function of the cytoplasm? [1]



34. The picture below shows a potato plant.

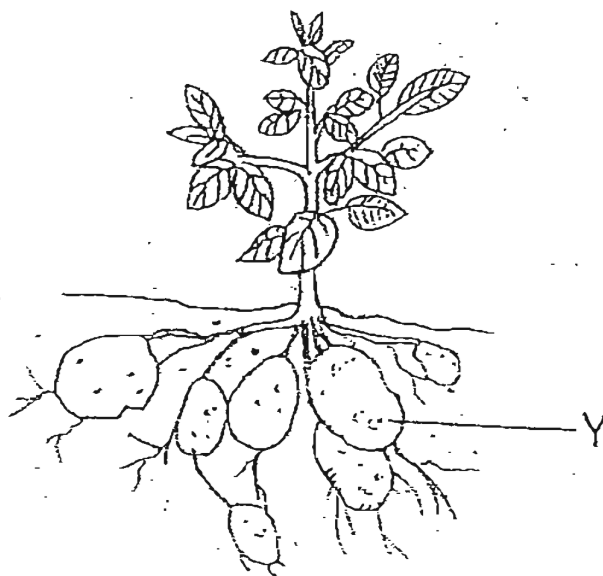

(a) Which part of the plant is Y?

[1]

(b) How is Y useful to the plant?

[1]

	2
--	---

35. The diagram below shows parts of the human body.

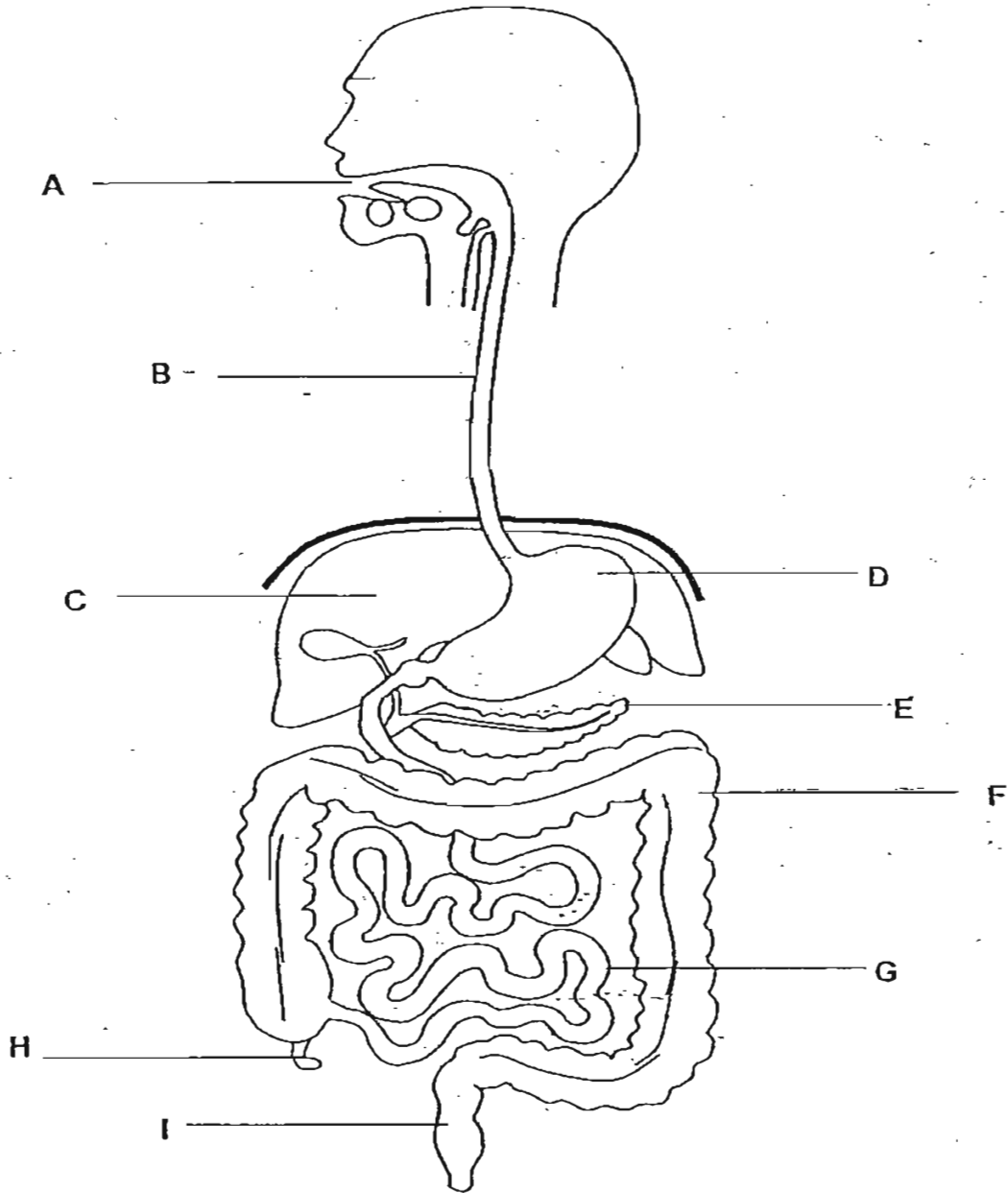

Using the appropriate letters (A to I) from the diagram above, list, in order, the organs each mouthful of food or drink passes through on its way through the digestive system. [2]

---

	2
--	---

36. The chart below shows the grouping of the dispersal methods of some fruits and seeds.

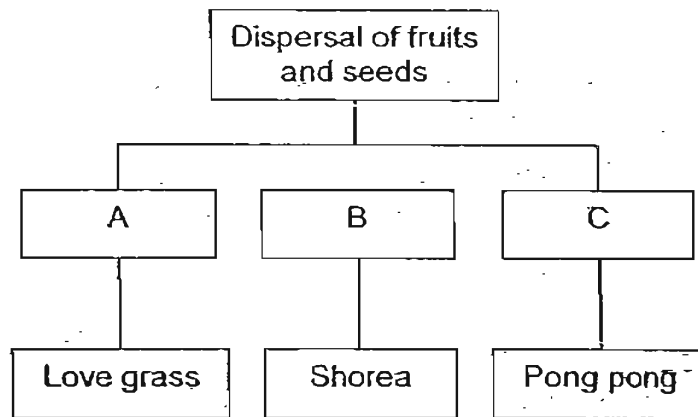

Based on the chart above, write down the method of seed dispersal and state how each of the plants adapts itself to the way its seeds are dispersed. [3]

	Method of dispersal	Adaptation
A		
B		
C		

37. Daniel wanted to show that plants produce carbon dioxide when they respire. The diagram below shows the materials which may be useful for his experiment.

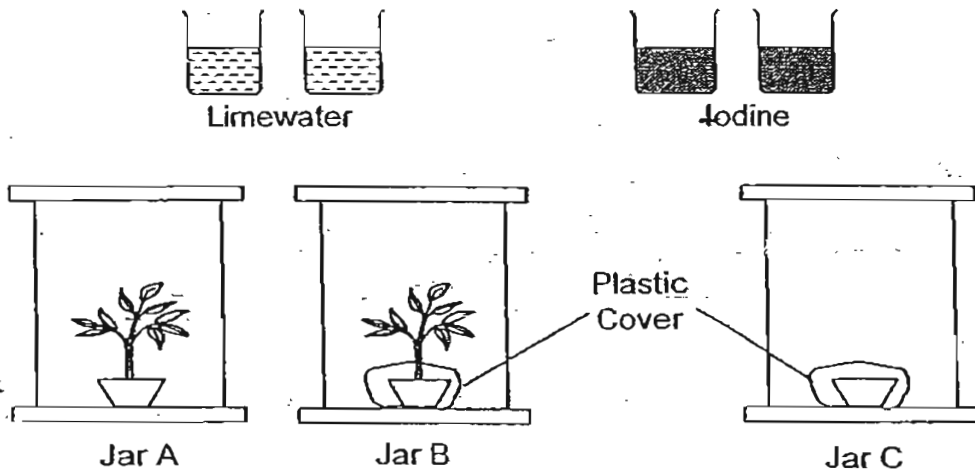

(a) Which items should he choose to conduct his experiment?  
Put a tick [✓] against the items chosen.

[2]

Jar A	
Jar B	
Jar C	
Limewater	
Iodine	

(b) Explain the purpose of the plastic cover.

[1]

---



---



38. Amy, Belinda and Carol were trying to make yoghurt in a home economics class using some milk and bacteria. They recorded their procedures and the results in the table below.

	Amy	Belinda	Carol
Step 1	a) Warm 50ml of milk at 75°C for 30 seconds.	a) Warm 50ml of milk at 75°C for 30 seconds. b) Cool the milk at 35°C	a) Warm 50ml of milk at 75°C for 30 seconds. b) Cool the milk at 35°C
Step 2	a) Add 1 portion of bacteria. b) Keep the mixture at 75°C for 3h.	a) Add 1 portion of bacteria. b) Keep the mixture at 35°C for 3h.	a) Add 1 portion of bacteria. b) Keep the mixture at room temperature for 3 days.
End Product	The final product taste like milk.	The final product is creamy and tastes slightly sour.	The final product is creamy and has many grey spots on the surface.

(a) Name the process that took place in Belinda's mixture:

[1]

---

(b) Give a possible reason to explain why the bacteria in Amy's milk was not effective.

[1]

---



---

(c) Give a possible reason to explain why there are grey spots on the surface of Carol's end product.

[1]

---



---

	3
--	---

39. Kok Beng used the set up below to investigate the flexibility of 2 different types of plastic strips, A and B. He secured one end of each type of plastic strips on top of a table at point X and put a weight on the other end.

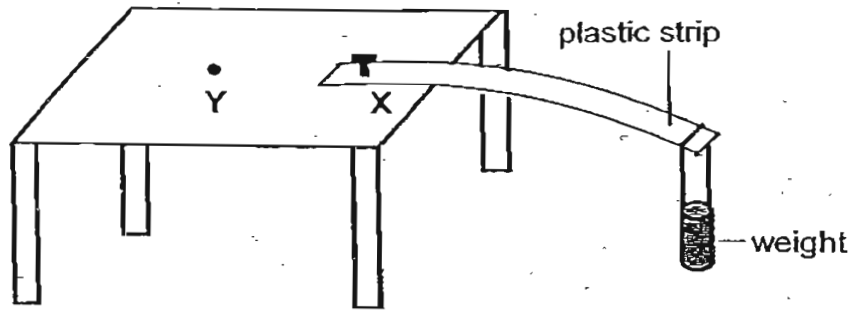

- (a) At the end of the investigation, he concluded that Plastic Strip B was more flexible than A. What observation enabled him to reach the conclusion? [1]

---

---

- (b) How would the results be different if Plastic Strip B was secured at position Y as compared to when it was in the original position? [1]

---

---



40. The picture below shows a method sometimes used for keeping food warm. The food is heated in the metal pot which is then placed in a styrofoam box. When the metal pot is removed from the styrofoam box, the food is still warm.

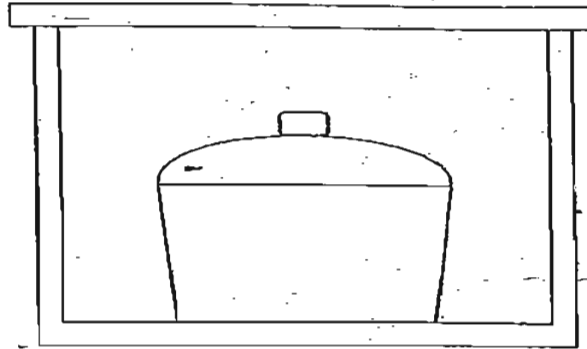

- (a) Explain how the styrofoam box reduces heat loss from the food. [1]

---

---

- (b) What other material could the pot be made of if you want to heat it over a flame as well as keep the food warm for a longer period of time? [1]

---

.	2
---	---

41. Alan carried out the following activity. He used 2 solid metal blocks of the same shape and size as shown in the diagram below. The mass of Block A was 50g but the mass of Block B was 80g.

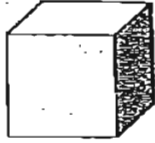

Block A

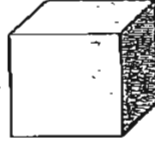

Block B

When he lowered Block A gently into a measuring cylinder containing 30ml of water, the water level rose as shown in the diagram below.

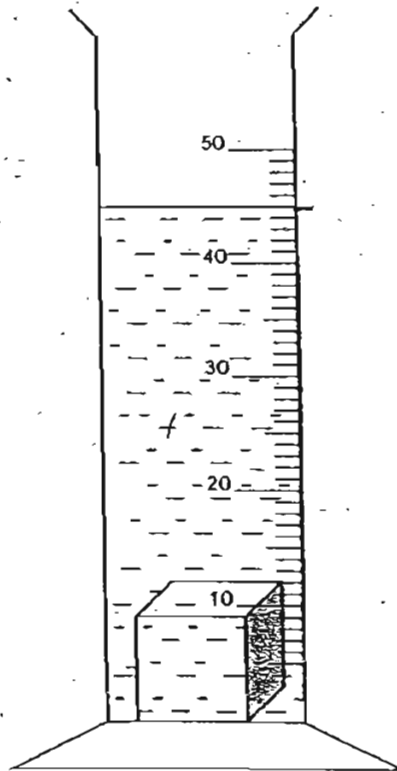

(a) What is the volume of Block A?

[1]

---

(b) Alan then took out Block A and put Block B into the water.  
Will the water level be the same, higher or lower than when Block A  
was put into the water?

[1]

---

(c) What is the reason for your answer in (b)?

[1]

---

---

	3
--	---

42. The diagram below shows a simple door bell.

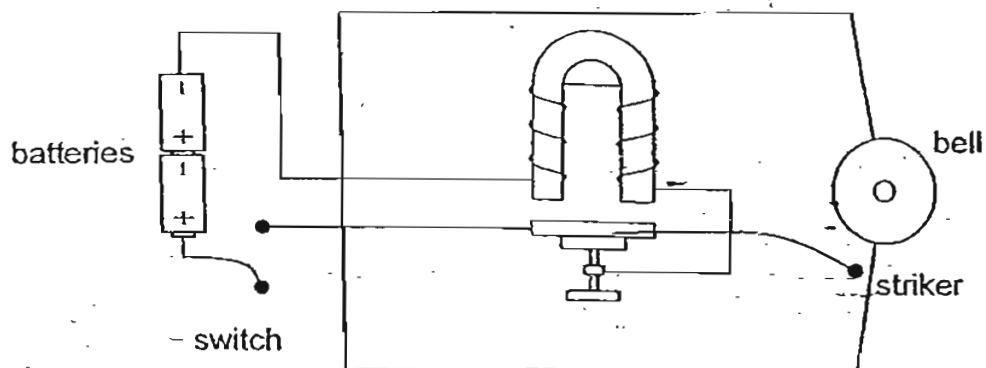

In the boxes below, write the energy changes that take place when the switch is closed.

[2]

in batteries



in circuit



of striker



from bell

	2
--	---

43. The diagram below shows how the water cycle recycles the water from the earth. The arrows show the different stages of water in motion. Study the diagram carefully and answer the questions below.

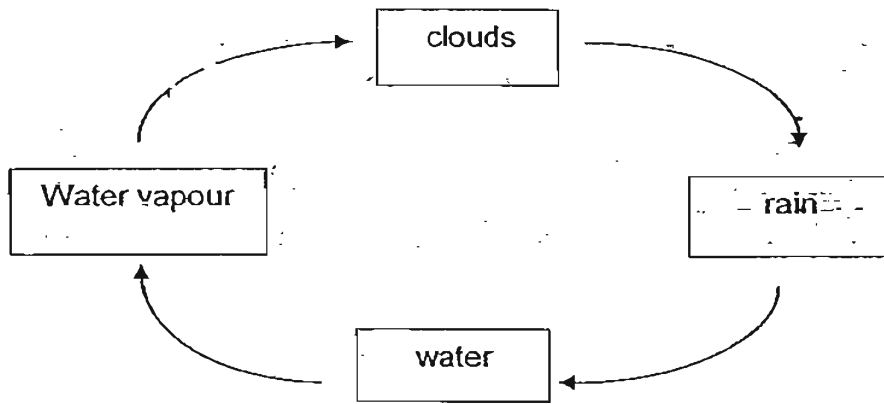

- (a) What causes the water to evaporate? [1]

---

- (b) Put a cross [X] on the correct arrow to show where condensation takes place. [1]

- (c) How is acid rain formed? [1]

---

---

44. A pupil was told to conduct an investigation to find out if plants grow towards sunlight using the items shown.

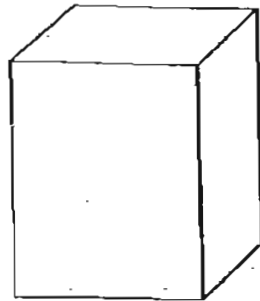

A styrofoam box with a cover



A pair of scissors



A potted plant

Draw a diagram to show the set-up at the end of the investigation. [2]

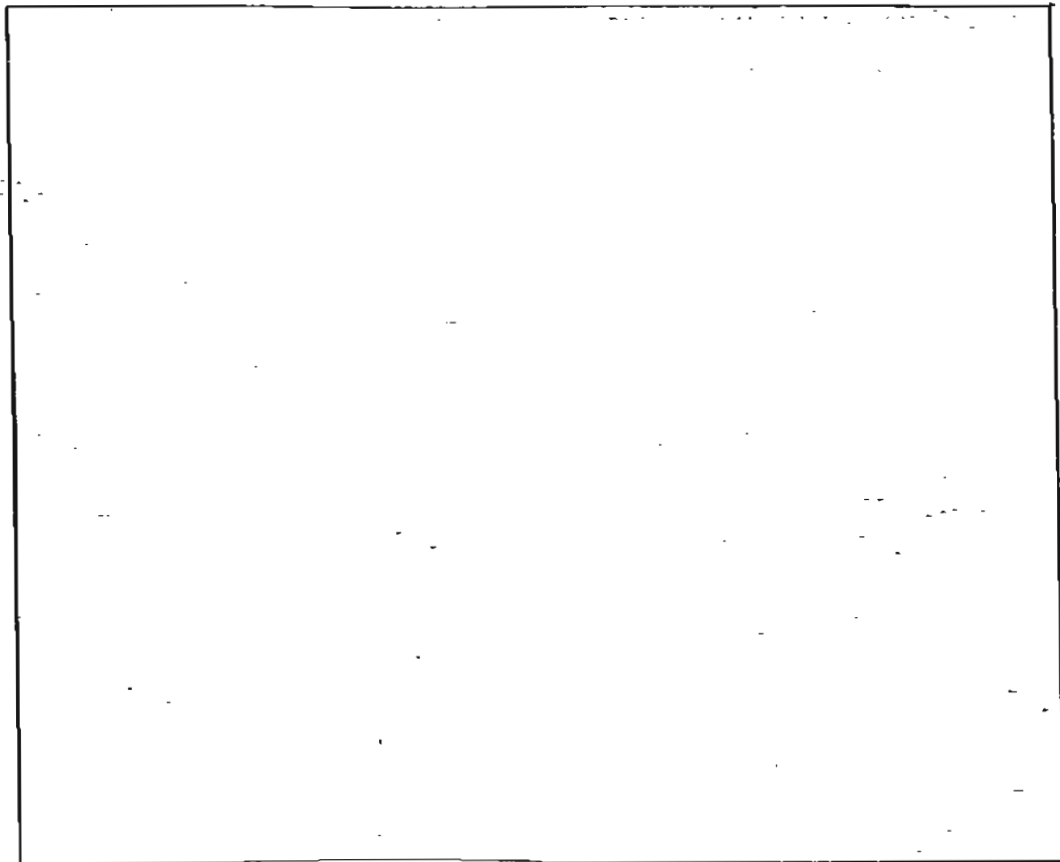



45. A boy threw a toy parachute from the top of the roof. Within seconds, it fell to the ground.

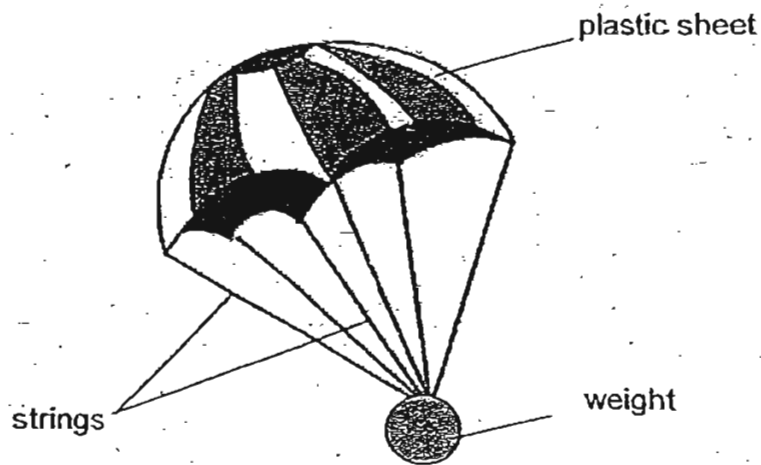

- (a) What was the force acting on it? [1]

---

- (b) Give one method to keep the parachute in the air for a longer time. [1]

---

---

	2
--	---

46. Matthew conducted an experiment with three different simple machines X, Y and Z. Using the information he collected from the experiment, he plotted the two graphs as shown below.

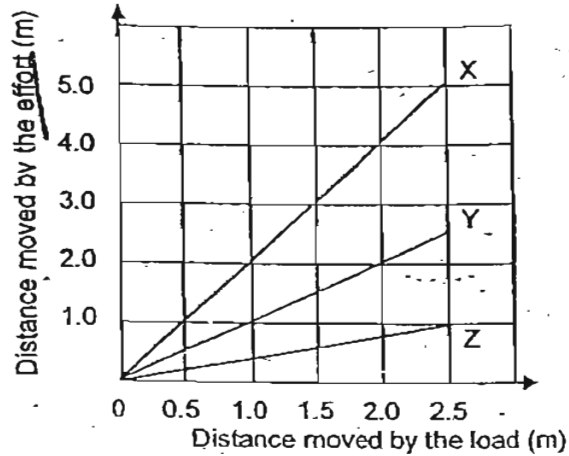
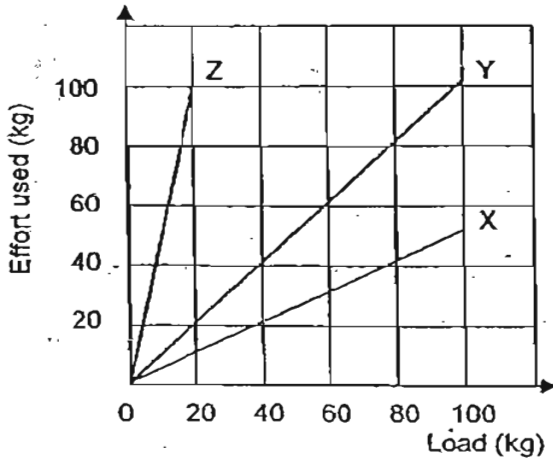

(a) What could simple machine Y possibly be? [1]

---

(b) What advantage and disadvantage did Matthew face when he used simple machine Z as compared to the other two machines? [2]

**Advantage:**

---



---

**Disadvantage:**

---



---

(c) Which of the above simple machines should Matthew use if he has to carry heavy loads? [1]

---

	4
--	---



37) a) Jar B ✓

Jar C ✓

Limewater ✓

b) It is to prevent carbon dioxide from the soil from escaping into the jar.

38) a) Fermentation.

b) She did not cool the mixture at step 1 but continued with step 2 immediately. She also kept the mixture at 75°C so the bacteria may have died and become useless.

c) When Carol kept the mixture at room temperature for 3 days, the bacteria and the yeast may have gone bad and some other micro-organisms in the air might have went into the mixture.

39) a) Plastic strip A snapped into two but plastic strip B did not.

b) Plastic strip B would not bend as much as it did as compared to when it was in the original position.

40) a) The Styrofoam box is a poor conductor of heat so it traps heat by not allowing it to go out but cold air is not able to get in.

b) Glass.

41) a) 15 cm<sup>3</sup>

b) The water level would be the same.

c) Although Block B has a bigger mass than Block A, the volume is still the same and it still covers the same area. In this case mass does not matter.

42) Chemical energy

Electrical energy

Kinetic energy

Sound energy

43) a) The heat from the sun.

b)

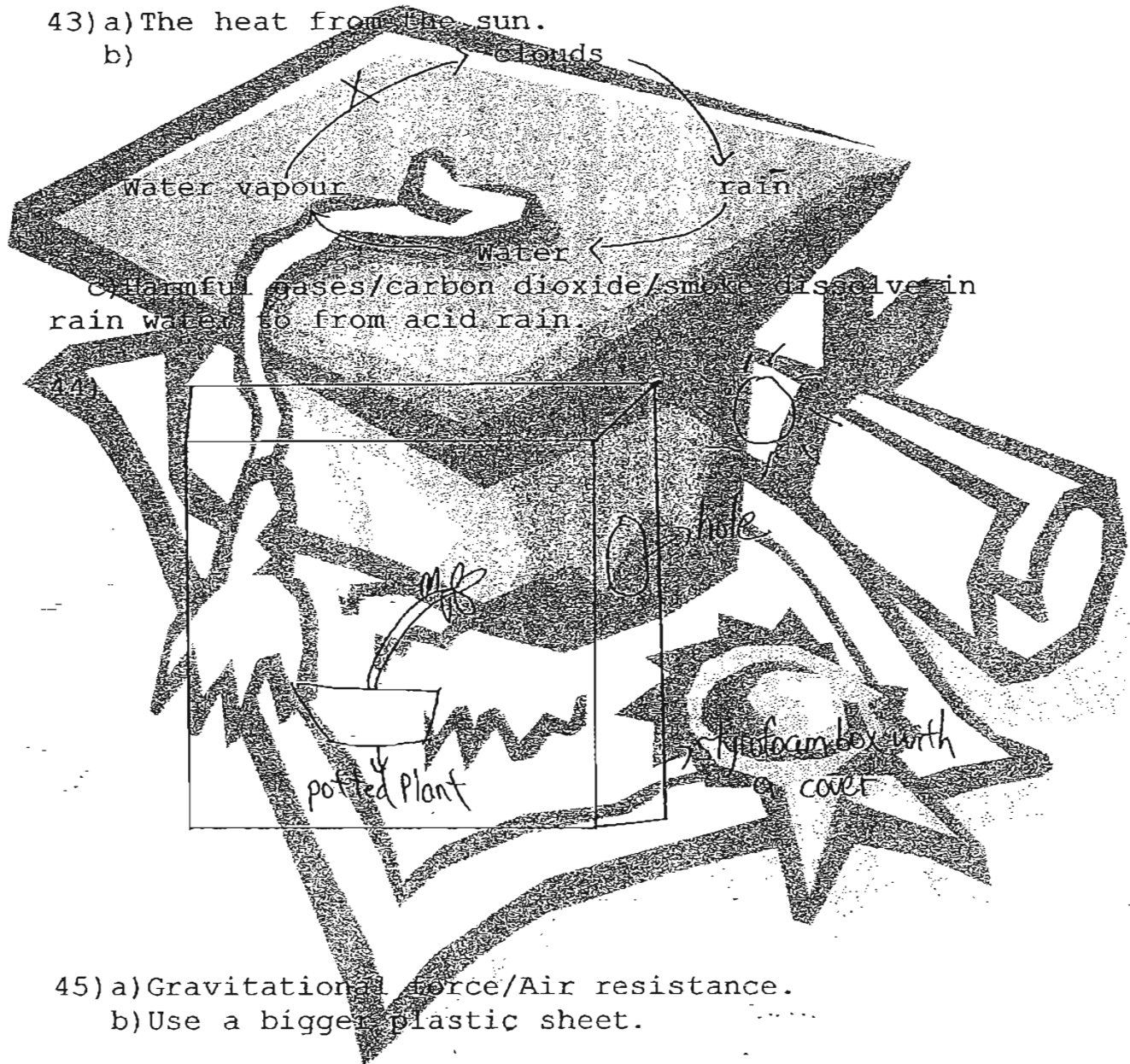

44) a) Gravitational force/Air resistance.

b) Use a bigger plastic sheet.

45) a) A fixed pulley.

b) Advantage: The distance moved by the load is greater than /The distance moved by the effort.

Disadvantage: The effort used is greater than the load.

c) Simple machine X.

---end---