

METHODIST GIRLS' SCHOOL

Founded in 1887



PRELIMINARY EXAMINATION 2014 PRIMARY 6 SCIENCE

BOOKLET A1

Total Time for Booklets A and B: 1 hour 45 minutes

INSTRUCTIONS TO CANDIDATES

Do not turn over this page until you are told to do so.

Follow all instructions carefully.

Answer all questions.

Shade your answers in the Optical Answer Sheet (OAS) provided.

Name: _____ ()

Class: Primary 6. _____

Date: 28 August 2014

This booklet consists of 14 printed pages including this page.

For each question from 1 to 30, four options are given, one of them is the correct answer. Make your choice (1, 2, 3 or 4). Shade the correct oval (1, 2, 3 or 4) on the Optical Answer Sheet.

[60 marks]

1. The following expression represents photosynthesis.

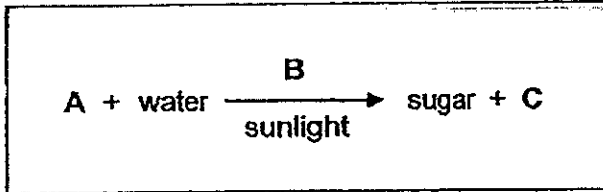

Which of the following shows the correct representation of A, B and C?

	A	B	C
(1)	air	green plants	water vapour
(2)	carbon dioxide	chlorophyll	oxygen
(3)	oxygen	chlorophyll	carbon dioxide
(4)	carbon dioxide	stomata	water vapour

2. Study the food web below carefully.

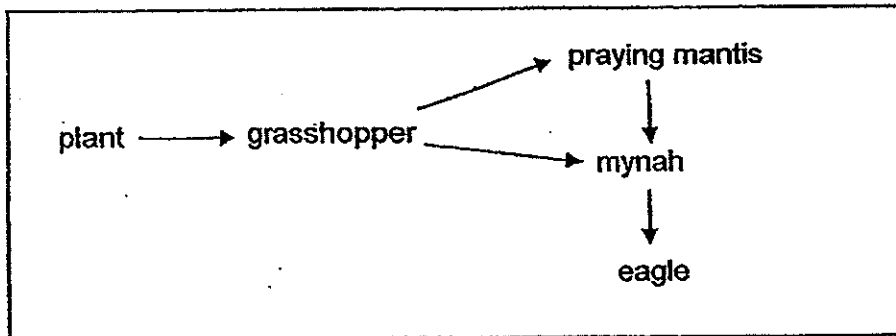

Which animal obtains the most amount of energy from the food it eats?

- (1) eagle
- (2) mynah
- (3) grasshopper
- (4) praying mantis

(Go on to the next page)

3. The flowchart shows some parts of the human body system(s). A and B are substances found in the blood taken from the small intestine.

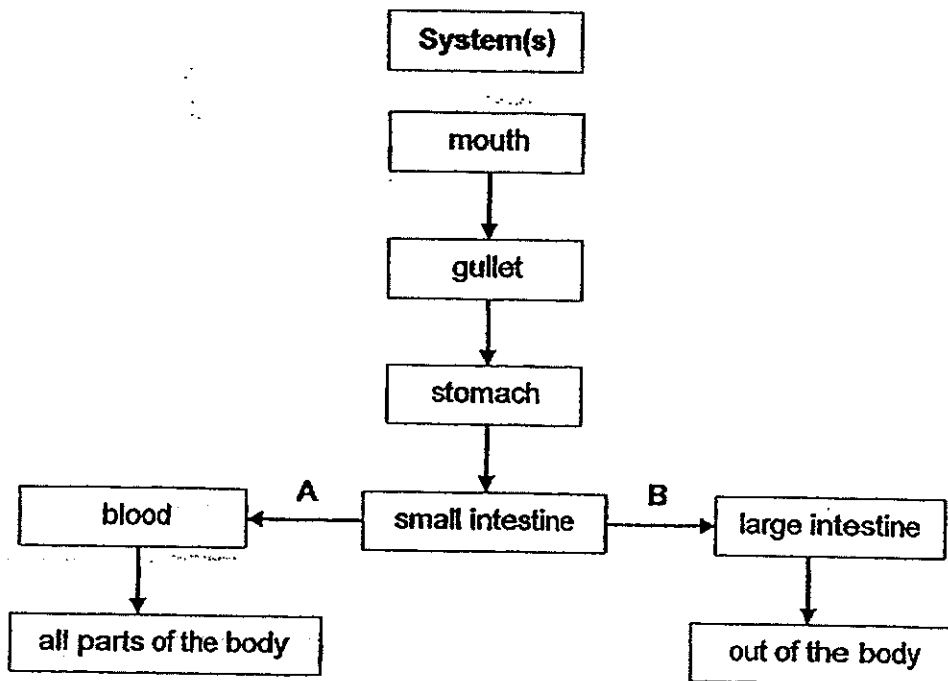

What do A, B and the above system(s) represent?

	Substance A	Substance B	System(s)
(1)	digested food	undigested food	digestive and circulatory systems
(2)	carbon dioxide	oxygen	circulatory systems
(3)	undigested food	digested food	digestive and circulatory systems
(4)	oxygen	carbon dioxide	digestive system

4. Jie Min found a spider crab with algae attached to its back. His teacher told him that this was a case of mutualism where both species benefit from each other. Which of the following statements are true?

- A: The spider crab would feed on the algae.
 B: The spider crab gives the algae a place to live in.
 C: The algae provide camouflage for the spider crab.
 D: The algae absorb nutrients from the spider crab until it dies.

- (1) A and C
 (2) A and D
 (3) B and C
 (4) B and D

(Go on to the next page)

5. Ali carried out an experiment to study the environment that worms preferred. Ten worms were put in a box which is divided into two separate parts, Part X and Part Y, as shown in the diagram below.

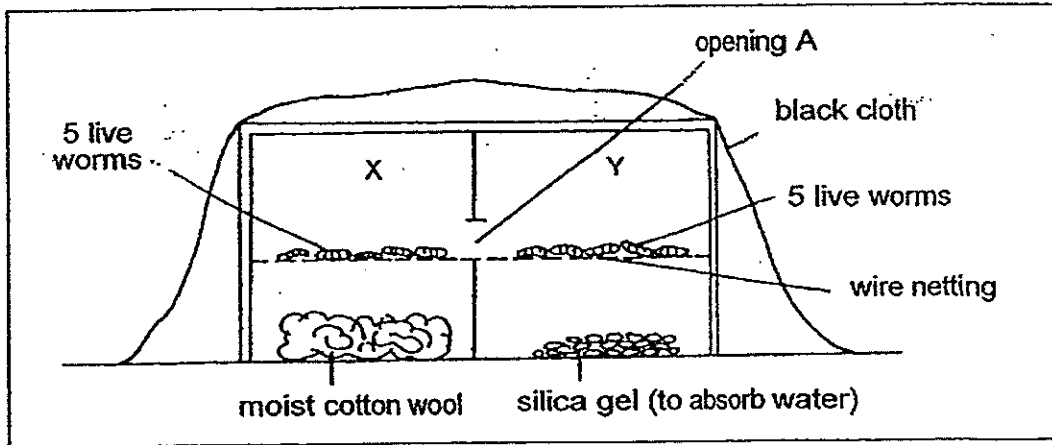

The live worms could move from Part X to Part Y through a small opening at A. After some time, it was observed that all the worms have moved into part X.

Which of the following set-ups would you use to find out how worms respond to light?

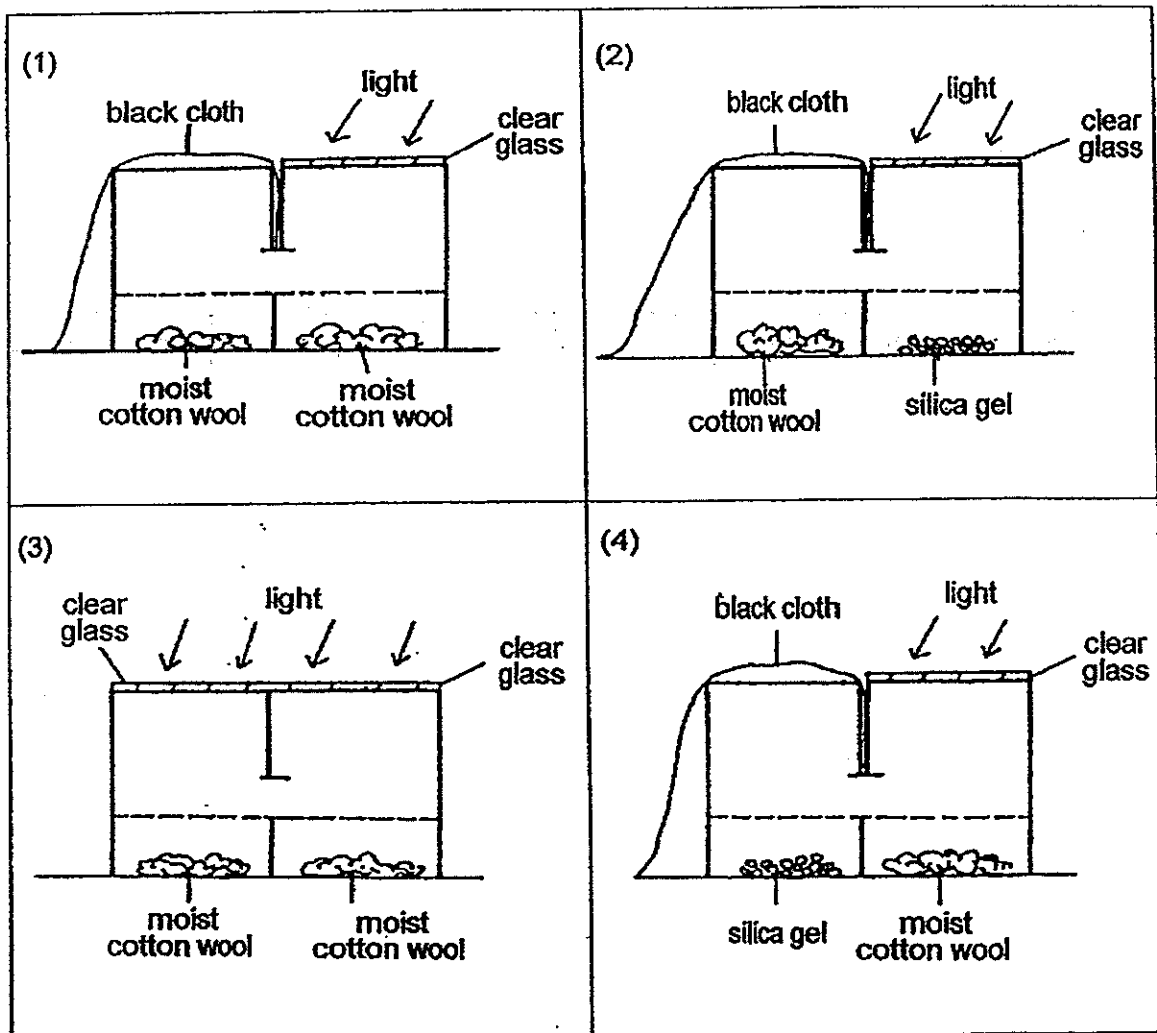

(Go on to the next page)

6. A group of students counted the organisms found in a pond. The results are shown below.

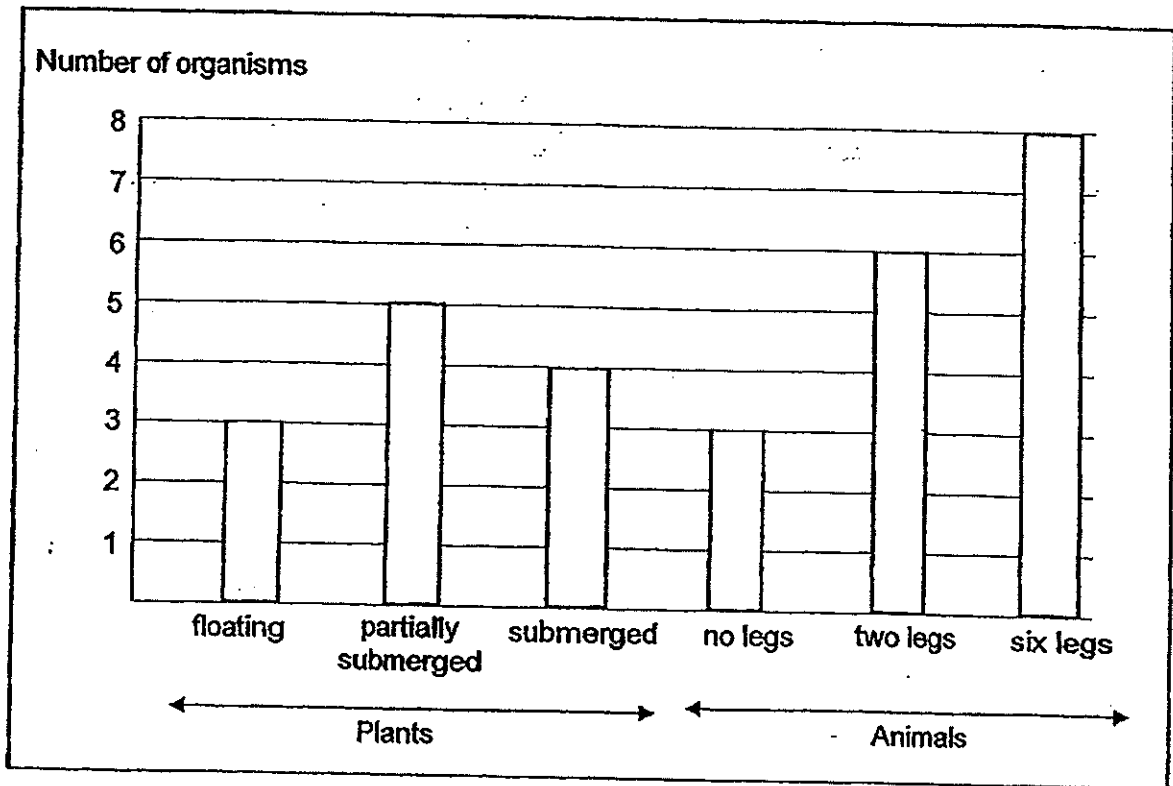

Which of the following statements about the plants and animals are correct?

- A: There are 12 populations of plants.
 B: There is only one pond community.
 C: There are at least three populations of animals.
 D: All the animals with no legs belong to one population.

- (1) A and B
 (2) B and C
 (3) A, B and C
 (4) B, C and D

(Go on to the next page)

7. P, Q, R and S were four different types of aquatic animals. Animals P and Q were placed in Aquarium A. Animals P and R were placed in Aquarium B. Animals Q, R and S were placed in Aquarium C. Some aquatic plants were placed in each of the aquariums. The number of animals in each aquarium was counted weekly and represented in the graphs shown below.

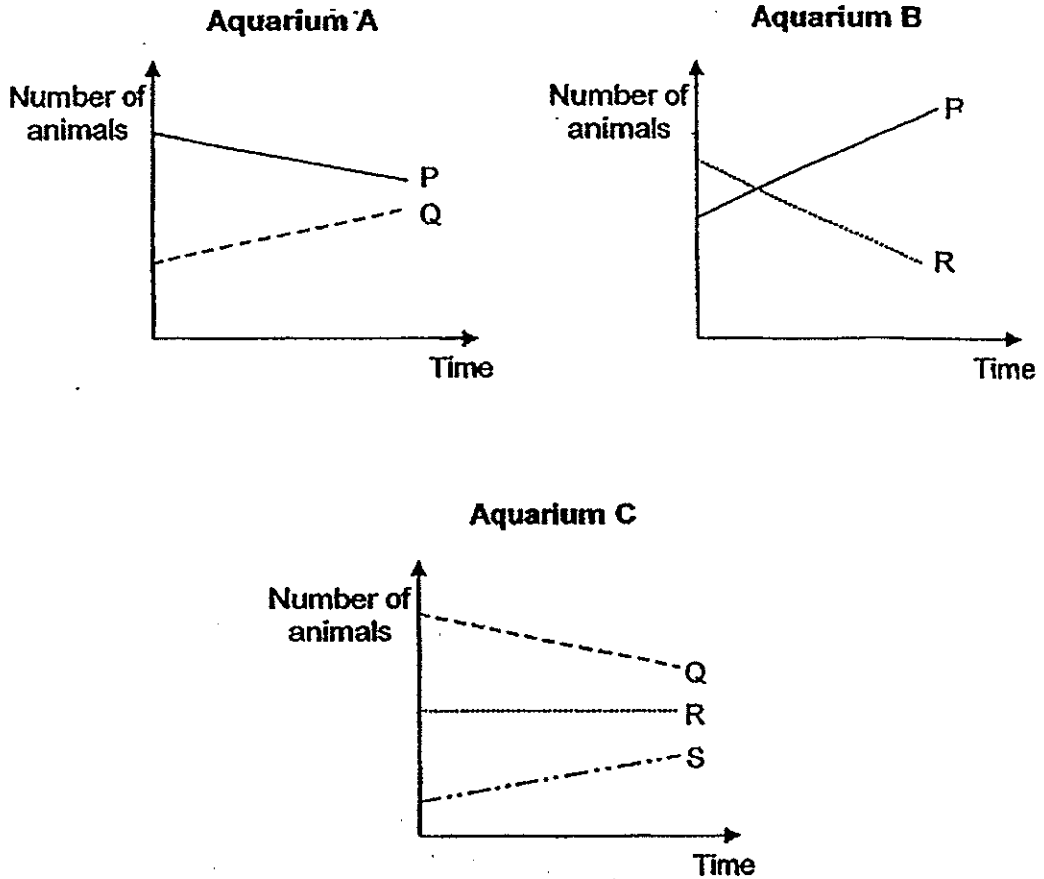

From the graphs above, which of the following correctly shows the most likely food chain linking the four animals?

- (1) Plants \rightarrow P \rightarrow R \rightarrow S \rightarrow Q
- (2) Plants \rightarrow R \rightarrow P \rightarrow S \rightarrow Q
- (3) Plants \rightarrow Q \rightarrow P \rightarrow R \rightarrow S
- (4) Plants \rightarrow R \rightarrow P \rightarrow Q \rightarrow S

(Go on to the next page)

8. The diagrams below show how animals move around in groups. Diagram Y shows the animals moving in herds while Diagram Z shows animals flying in a V-shaped formation.

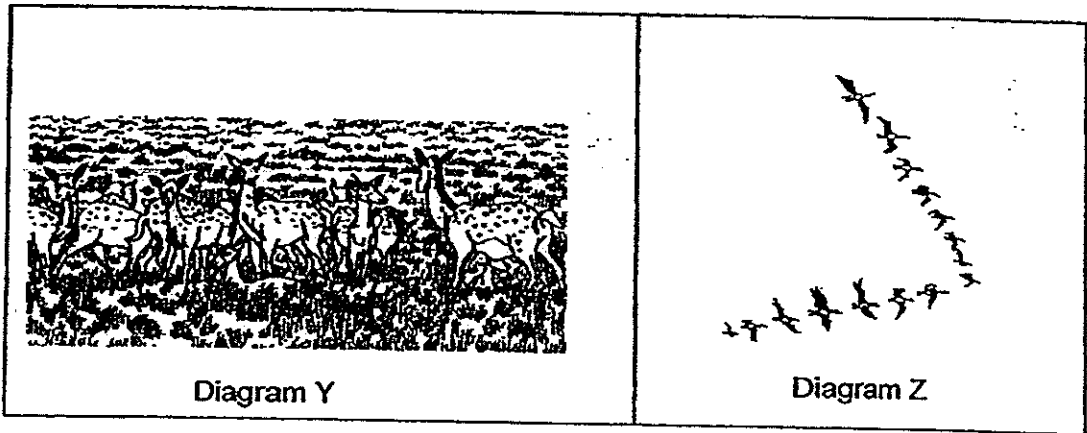

Which one of the following correctly explains why these animals move in the manner as shown above?

	Y	Z
(1)	To keep themselves warm from the chilly winds	To escape from hunters
(2)	To confuse the predators from identifying one to target at	To facilitate easier communication with each other for food
(3)	To make it more difficult for predators to capture them	To enable them to fly more easily for a longer period of time
(4)	To make loud noise with their hooves to scare predators away	To invite more animals to join in the formation

(Go on to the next page)

9. The chart below shows human activities which have negative impact on the earth.

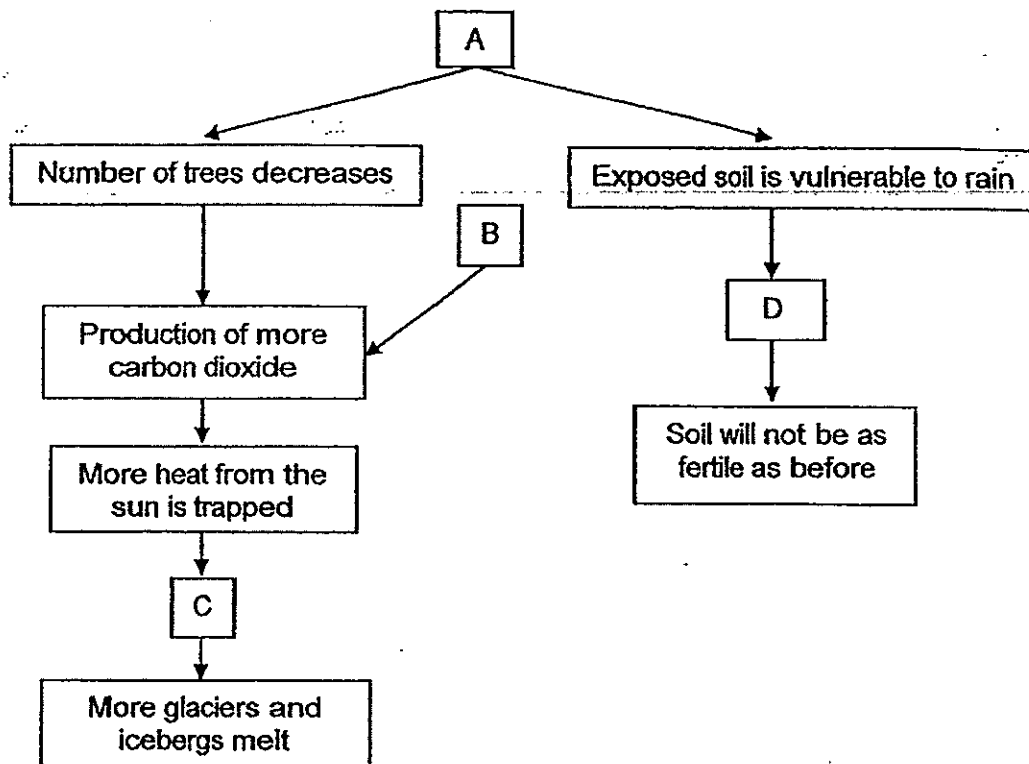

Which of the following shows the correct representation of A, B, C and D?

	A	B	C	D
(1)	Global warming	Greenhouse Effect	Burning of fossil fuels	Soil erosion
(2)	Deforestation	Burning of fossil fuels	Global warming	Soil erosion
(3)	Greenhouse effect	Global warming	Deforestation	Burning of fossil fuels
(4)	Deforestation	Global warming	Burning of fossil fuels	Soil erosion

(Go on to the next page)

10. Siti filled up a bag, made of special material, with colourless sugar solution. She then twisted and tied the bag up to ensure its contents are secure. Thereafter, she lowered the bag into a glass container filled with yellowish-brown iodine solution.

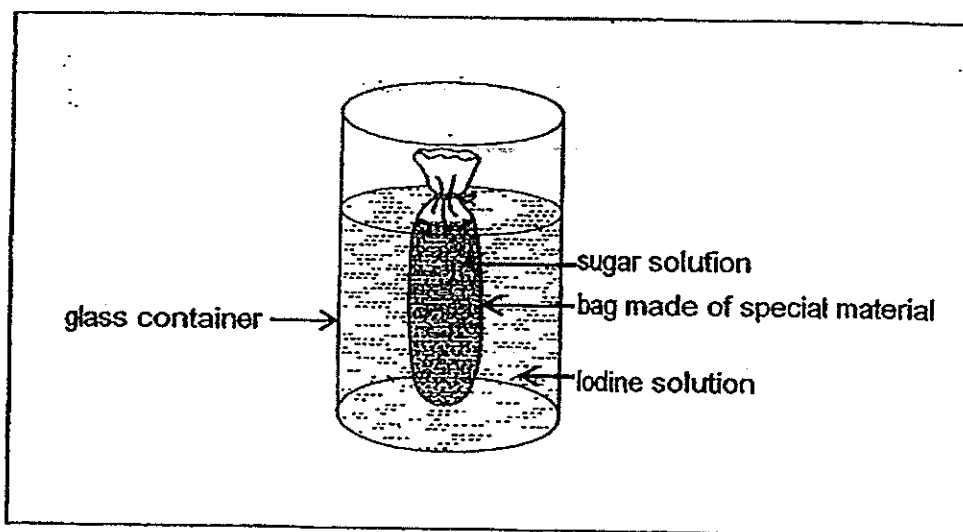

After seven hours, the sugar solution in the bag turned dark blue. However, the iodine solution in the glass container remained unchanged.

What could be concluded from the experiment above?

- (1) The bag does not allow the sugar solution to pass through.
- (2) The iodine solution is able to pass through the bag and mix with the sugar solution.
- (3) The sugar solution is able to pass through the bag and mix with the iodine solution.
- (4) The bag is a semi-permeable membrane that does not allow iodine solution to pass through.

(Go on to the next page)

11. The diagram below shows a plant.

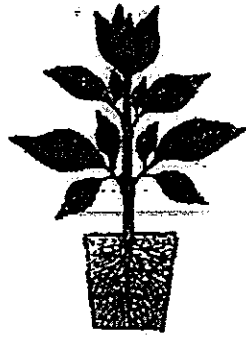

Which of the following statements about the parts of the plant are correct?

- A: The stem helps the plant remain upright.
- B: The roots take in food and water from the soil.
- C: The roots spread out to reach for water and minerals.
- D: The leaves spread out to receive sunlight, air and water.

- (1) A and C only
- (2) A, B and C only
- (3) A, C and D only
- (4) All of the above

(Go on to the next page)

12. The diagram below shows how blood is transported around the body.

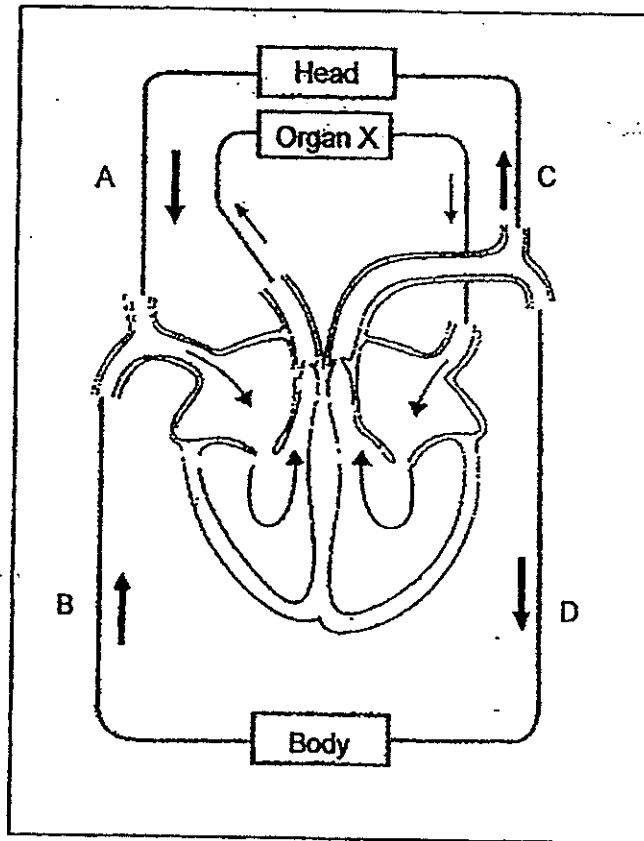

Based on the diagram above, identify the type of blood indicated by the arrows, A, B, C and D.

	A	B	C	D
(1)	Rich in oxygen	Rich in oxygen	Poor in oxygen	Poor in oxygen
(2)	Rich in oxygen	Poor in oxygen	Rich in oxygen	Poor in oxygen
(3)	Poor in oxygen	Rich in oxygen	Poor in oxygen	Rich in oxygen
(4)	Poor in oxygen	Poor in oxygen	Rich in oxygen	Rich in oxygen

(Go on to the next page)

13. The flow chart shown below describes parts of the human male and female reproductive system.

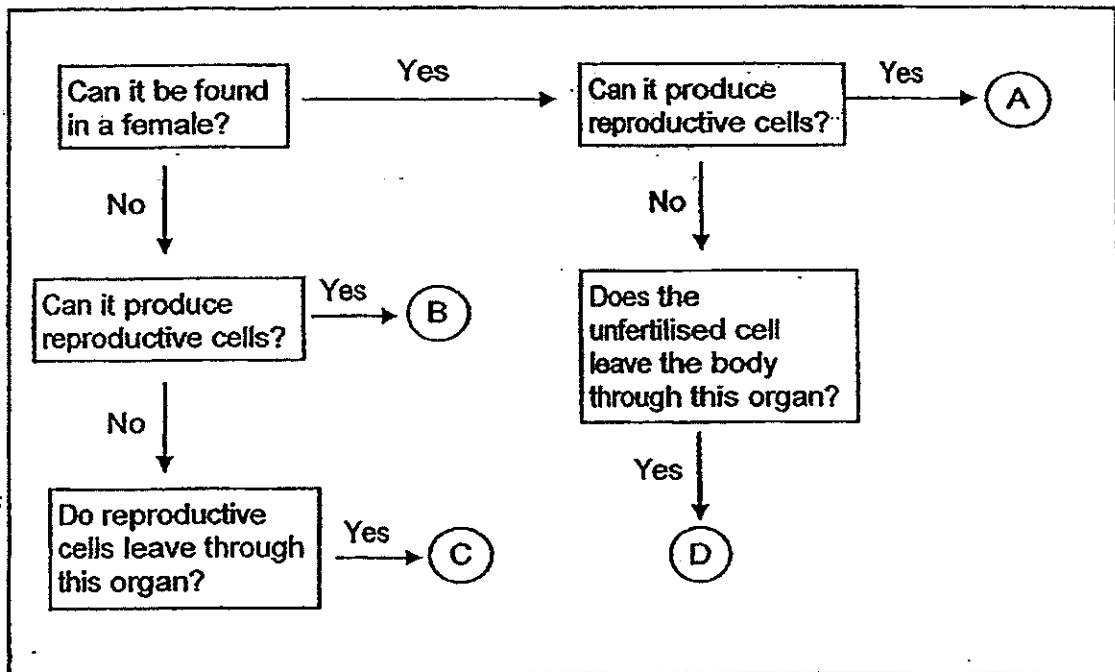

Which of the following represents A, B, C and D respectively?

	Part A	Part B	Part C	Part D
(1)	egg	testes	uterus	penis
(2)	testes	egg	penis	uterus
(3)	ovary	sperm	vagina	penis
(4)	ovary	testes	penis	vagina

(Go on to the next page)

14. The diagram below shows a type of flower planted in Ben's garden.

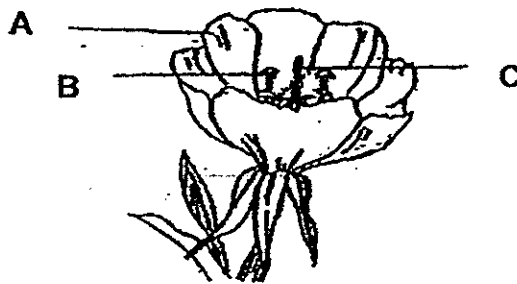

Ben wanted to know if a fruit can be formed when a certain part of the flower is removed.

Bill removed different parts from 3 identical flowers X, Y and Z as shown below. He then scattered equal amount of similar pollen grains onto flowers X, Y and Z and observed them some time.

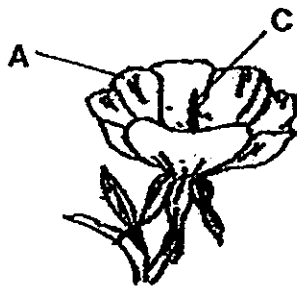

Flower X



Flower Y

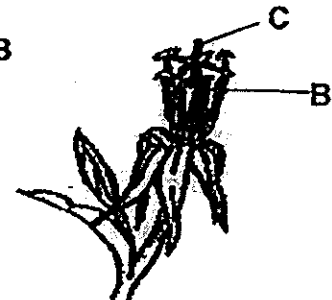

Flower Z

Which of the following flowers will most likely develop into a fruit?

- (1) Y and Z only
- (2) X and Y only
- (3) X and Z only
- (4) X, Y and Z

(Go on to the next page)

15. Study the diagrams as shown below. *living things*
Which of the following show the life cycles of plants correctly?

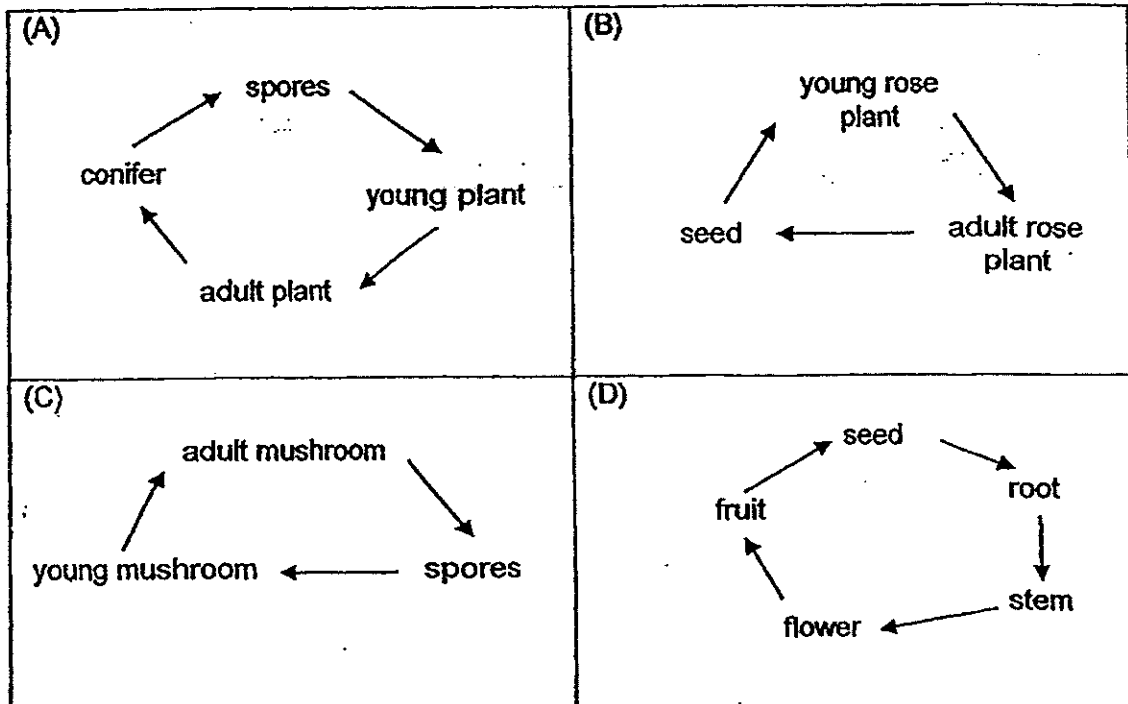

- (1) B and C only
 (2) A, B and C only
 (3) B, C and D only
 (4) All of the above

METHODIST GIRLS' SCHOOL

Founded in 1887



PRELIMINARY EXAMINATION 2014 PRIMARY 6 SCIENCE

BOOKLET A2

Total Time for Booklets A and B: 1 hour 45 minutes

INSTRUCTIONS TO CANDIDATES

Do not turn over this page until you are told to do so.
Follow all instructions carefully.

Answer all questions.

Shade your answers in the Optical Answer Sheet (OAS)
provided.

Name: _____ ()

Class: Primary 6. _____

Date: 28 August 2014

This booklet consists of 15 printed pages including this page.

For each question from 16 to 30, four options are given. One of them is the correct answer. Make your choice (1, 2, 3 or 4). Shade the correct oval (1, 2, 3 or 4) on the Optical Answer Sheet provided.

Study the following and answer questions 16 and 17.

16. Susan accidentally stepped on a table tennis ball. As a result, a dent was created as shown in the diagram below. Susan inspected the ball and observed that it was not broken and there were no holes on it.

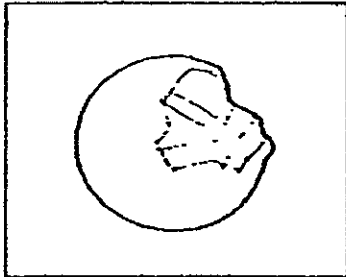

Which of the following correctly shows the changes in the table tennis ball before and after it was stepped on?

	Before		After	
	Mass of table tennis ball (g)	Volume of air in table tennis ball (cm^3)	Mass of table tennis ball (g)	Volume of air in table tennis ball (cm^3)
(1)	2.5	8	2.5	8
(2)	2.5	8	2.5	7.5
(3)	2.5	8	2	8
(4)	2.5	8	2	7.5

17. Susan then placed the dented table tennis ball into a beaker of hot water. She observed that it became round again.

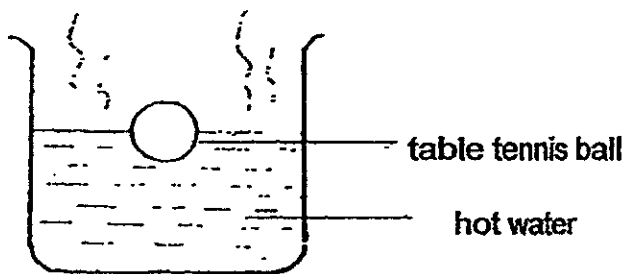

Which one of the following correctly explains her observation?

- (1) The table tennis ball lost heat to the hot water and expanded.
- (2) The air inside the table tennis ball gained heat and expanded.
- (3) The heat from the hot water caused the table tennis ball to harden.
- (4) The hot water in the beaker exerted a force on the outer wall of the table tennis ball.

(Go on to the next page)

18. Mrs. Raja set up an experiment as shown in the diagram below. When the strings were cut, the stationary balls dropped and created a dent in the tray of flour. She then measured the depth of each dent.

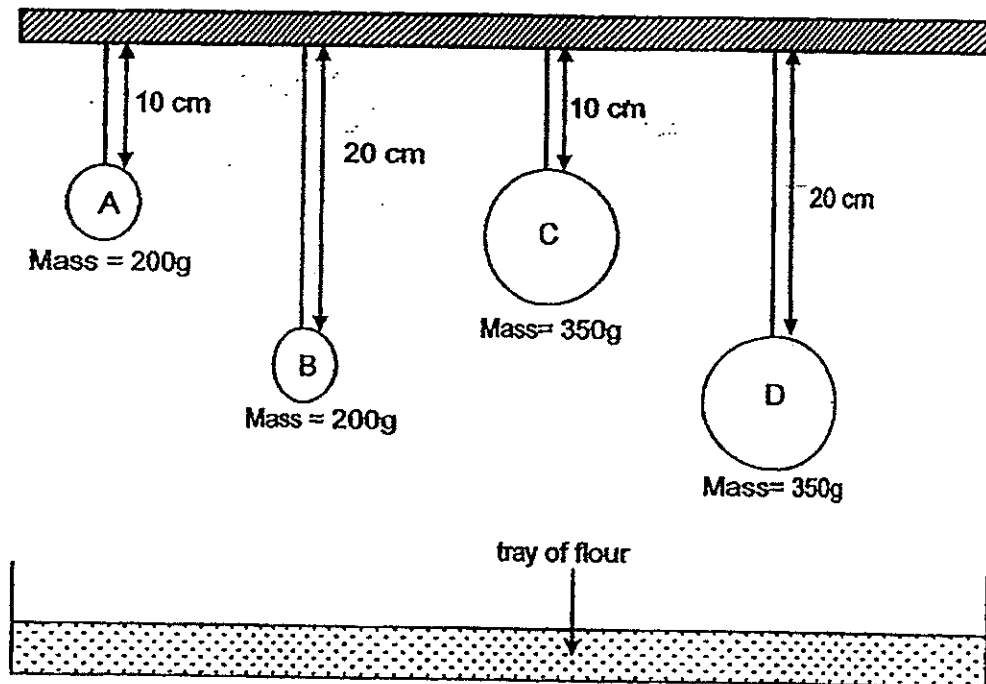

Four students made some statements based on the experiment above.

Ahmad: Ball A and C has the same amount of gravitational potential energy.

Bernard: All the balls possessed zero kinetic energy when they are suspended above the flour.

Chi Wei: Ball D will create a deeper dent than Ball C.

Devi: Ball C will create the deepest dent.

Which of the following statements is/are correct?

- (1) Devi only
- (2) Bernard and Devi only
- (3) Ahmad and Chi Wei only
- (4) Bernard and Chi Wei only

(Go on to the next page)

19. Jack set up an experiment as shown in the diagram below to move a water wheel.

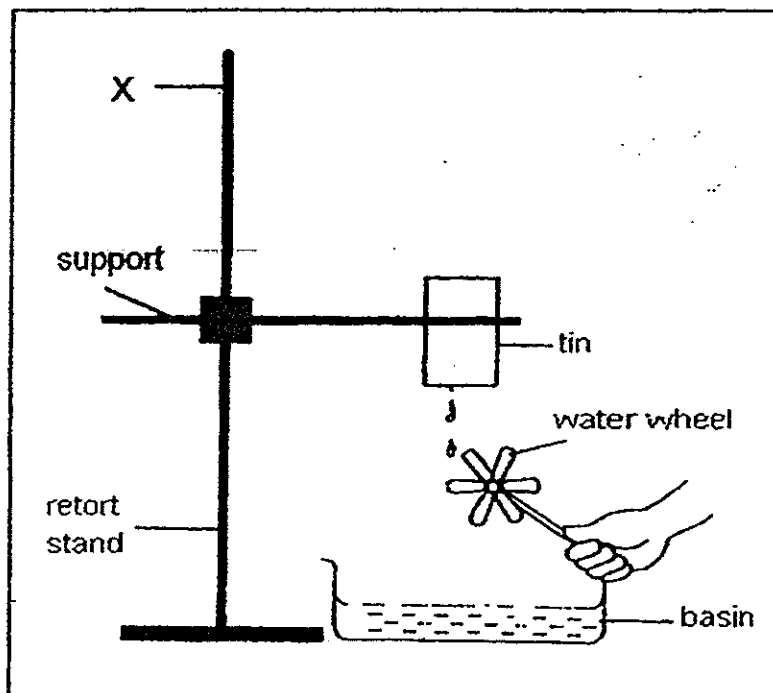

Which of the following predictions is/are correct if Jack were to raise the support for the tin to Position X?

- A: The water wheel will spin faster.
- B: The water wheel will spin slower.
- C: The stream of water has more gravity acting on them.
- D: The stream of water possessed more gravitational potential energy.

- (1) A only
- (2) A and C only
- (3) B and D only
- (4) A and D only

20. Substance K has a melting point of 10°C and a boiling point of 70°C . Cindy took Substance K from the freezer compartment of the fridge and placed it on a table in a room until it became a liquid. She waited for a while before she heated Substance K until it boiled.

Which one of the following graphs best represents the change in temperature of Substance K?

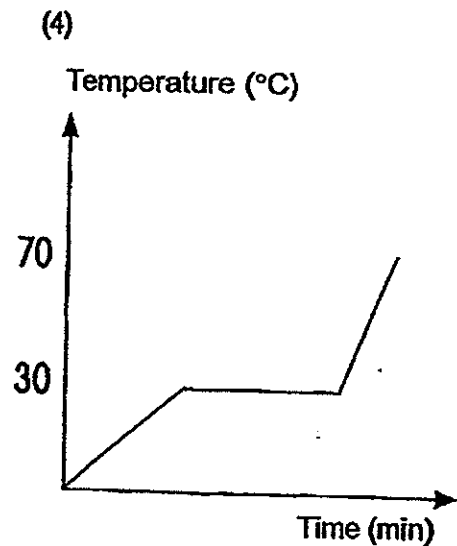
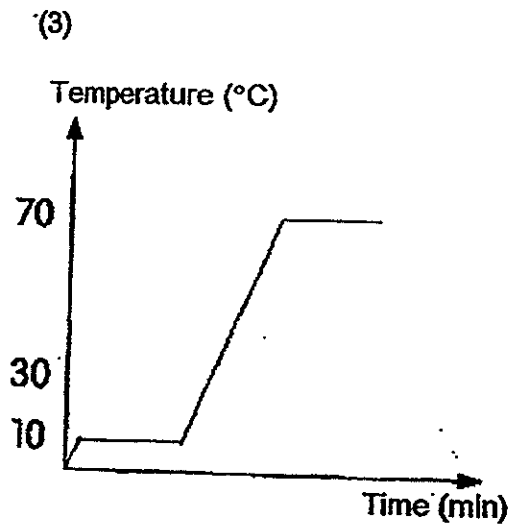
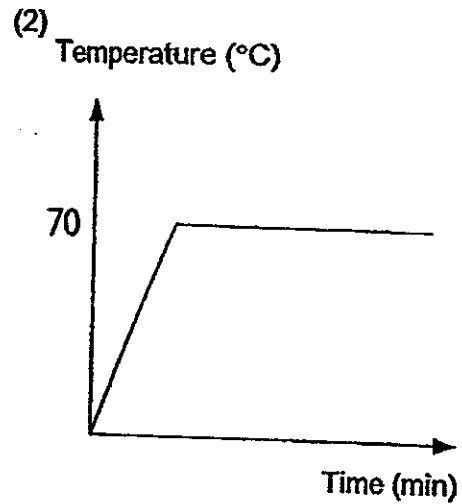
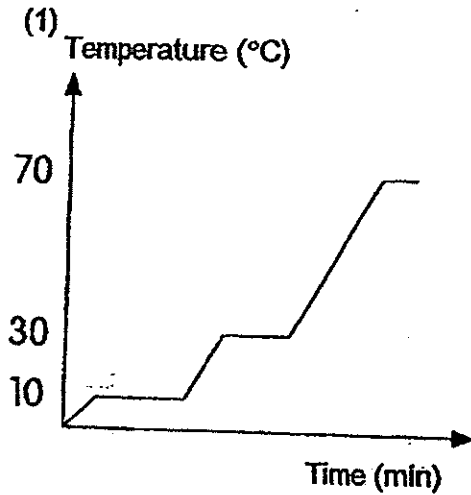

(Go on to the next page)

21. A circuit comprising identical bulbs, batteries and switches was set up as shown in the diagram below.

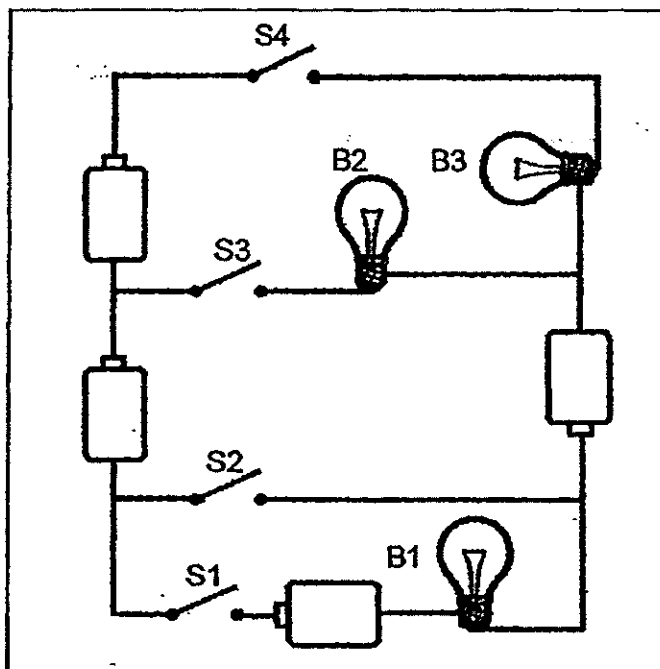

Which of the following pair of switches, when closed, would cause only one bulb to light up?

- A: S1 and S3
 B: S1 and S4
 C: S2 and S3
 D: S2 and S4
- (1) A and B only
 (2) A and D only
 (3) B and C only
 (4) C and D only

(Go on to the next page)

22. A ball was pushed and it rolled from P to S along a track as shown in the diagram below.

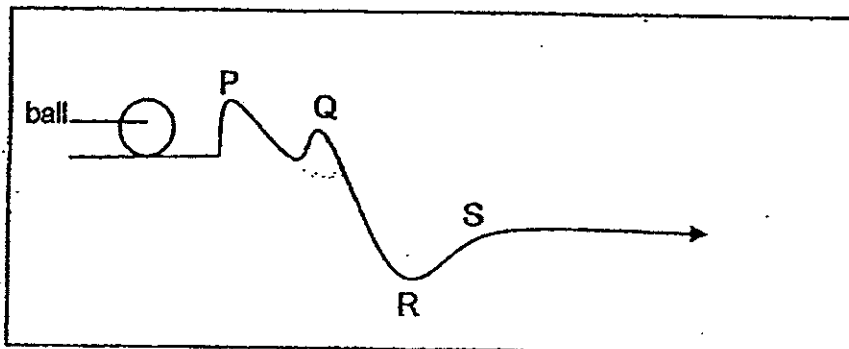

At which point P, Q, R or S did the ball have the highest speed?

- (1) P
- (2) Q
- (3) R
- (4) S

(Go on to the next page)

23. Ahmad carried out an experiment by using a spring hung on a hook and some loads as shown in the diagram. He then added the loads, one at a time and recorded the extension of the spring accordingly. When the last load was added, the spring was stretched beyond its elasticity limit.

After that, Ahmad removed the load one at a time and recorded the extension of the spring accordingly.

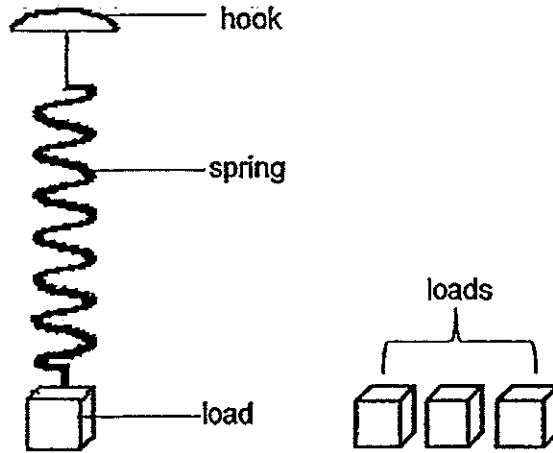

Which one of the following graphs correctly shows the extension of the spring in Ahmad's experiment?

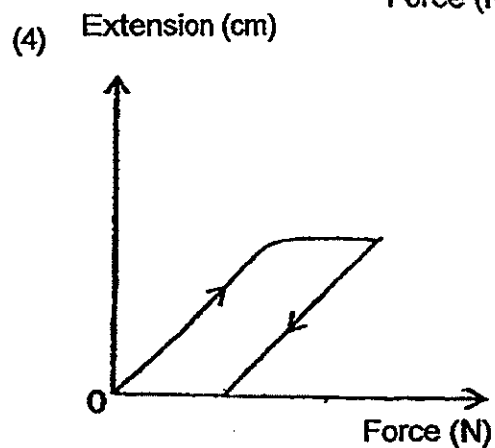
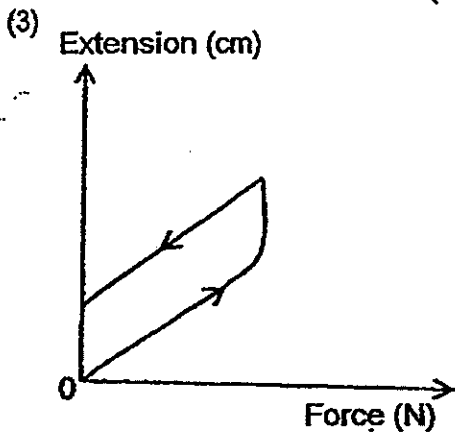
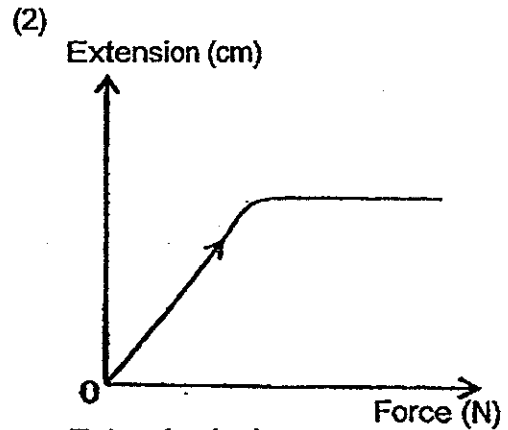
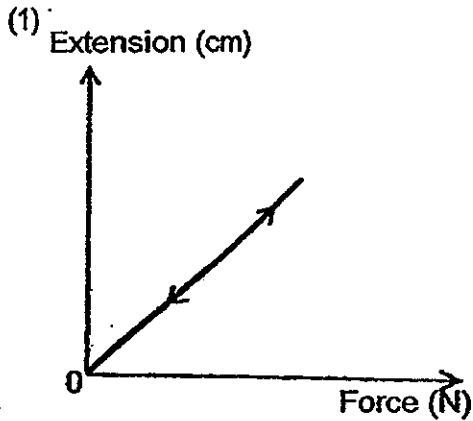

(Go on to the next page)

24. Pin Pin prepared the following set up as shown in the diagram below. Magnet A and C were mounted on ceramic stands while Magnet B was mounted on a thin piece of plastic with wheels. Pin Pin pushed Magnet B towards one of the magnets and observed that Magnet B was able to move between the two magnets continuously.

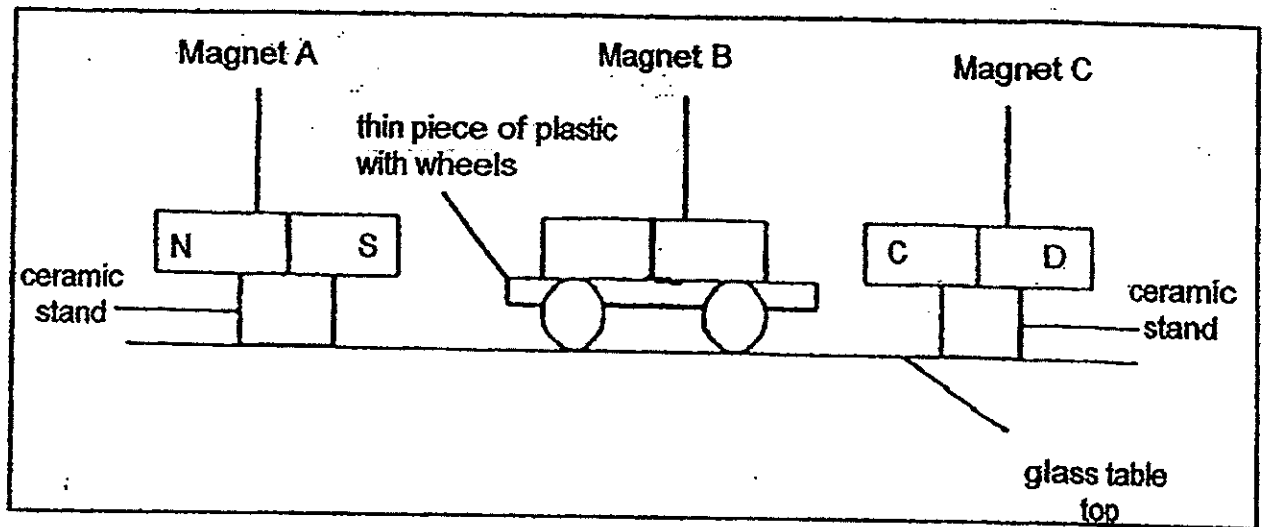

Which one of the following statements is correct?

- (1) Pole D of Magnet C is a North Pole.
- (2) Magnet B will become a stronger magnet.
- (3) Magnetic force of repulsion caused Magnet B to move continuously.
- (4) Frictional force between the wheels of the car and the glass table top caused Magnet B to move continuously.

(Go on to the next page)

25. Bala set up the following experiment as shown in Diagram 1. Six identical rings of the same size, A, B, C, D, E and F are stacked through a wooden rod. Five of them are magnets.

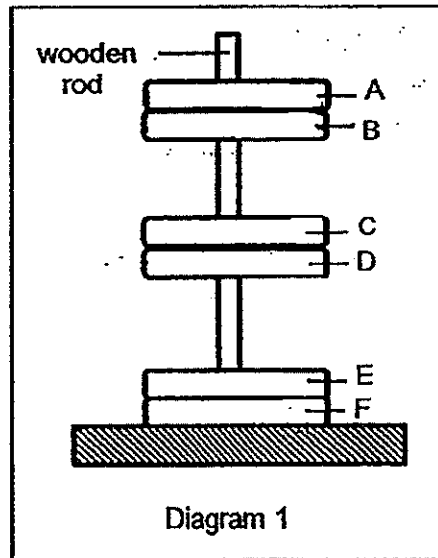

The rings are then removed and stacked in another way through the wooden rod in Diagram 2.

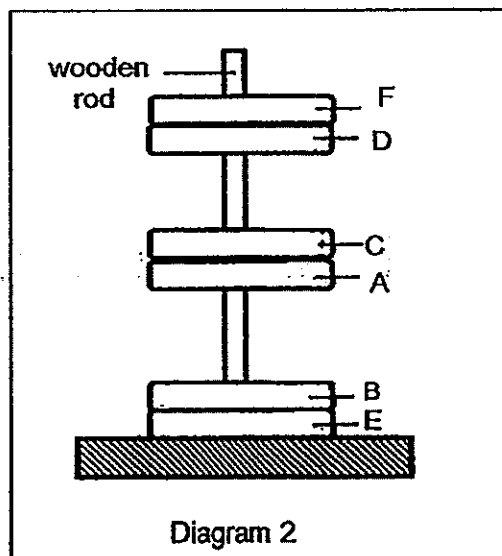

Which one of the following rings is most likely not a ring magnet?

- (1) B
- (2) C
- (3) D
- (4) F

(Go on to the next page)

26. The following table shows the boiling point and melting points of four substances, W, X, Y and Z.

Substance	Melting point (°C)	Boiling point (°C)
W	0	100
X	-25	80
Y	20	90
Z	40	120

At which of the following temperature(s) would all the substances be at the same state?

- A: 0°C
- B: 45 °C
- C: 100°C
- D: 150°C

- (1) B only
- (2) A and C only
- (3) B and D only
- (4) A, C and D only

(Go on to the next page)

27. Noraini wanted to find out how the distance between a light source and a pen would affect the length of the shadow cast by the pen. She placed the light source at position W and the pen at position Z as shown in the diagram below and observed a 10 cm shadow on the screen.

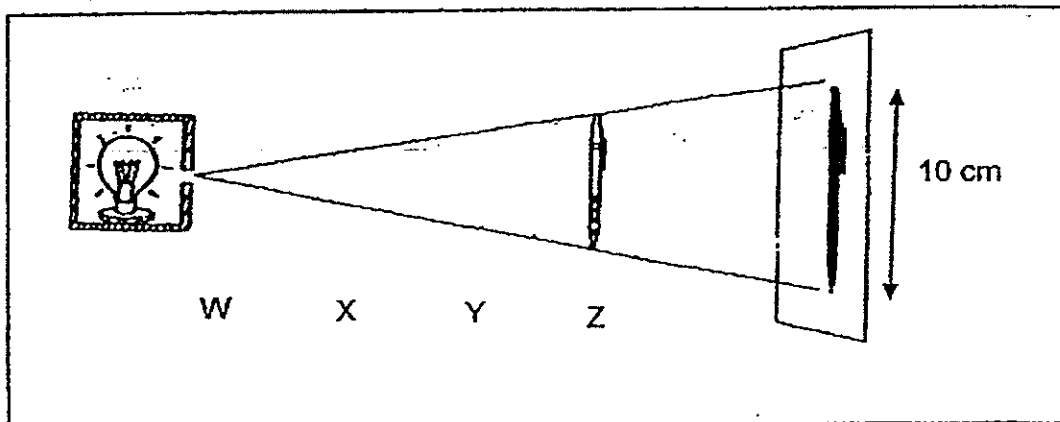

She adjusted the light source and the pen at different positions and measured the lengths of the shadows accordingly as shown in the diagram above and recorded her observations.

What would be the likely length of the shadow based on the positions of the light source and the pen?

	Position of light source	Position of pen	Length of shadow (cm)
(1)	W	X	15
(2)	W	Y	8
(3)	X	Z	7
(4)	Y	Z	10

28. Four different pieces of materials, A, B, C and D of the same dimensions were used in an experiment. A hole was cut from each material as shown in the diagram below.

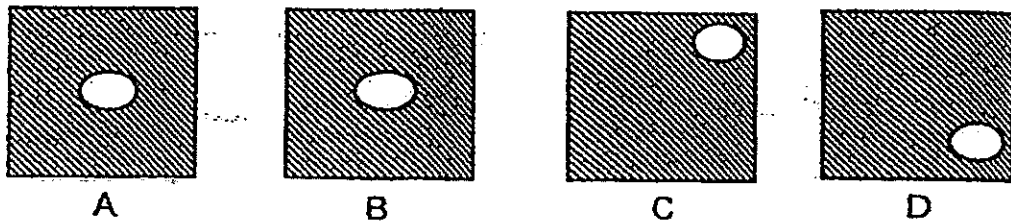

The materials were then used in the following set up as shown in the diagram below:

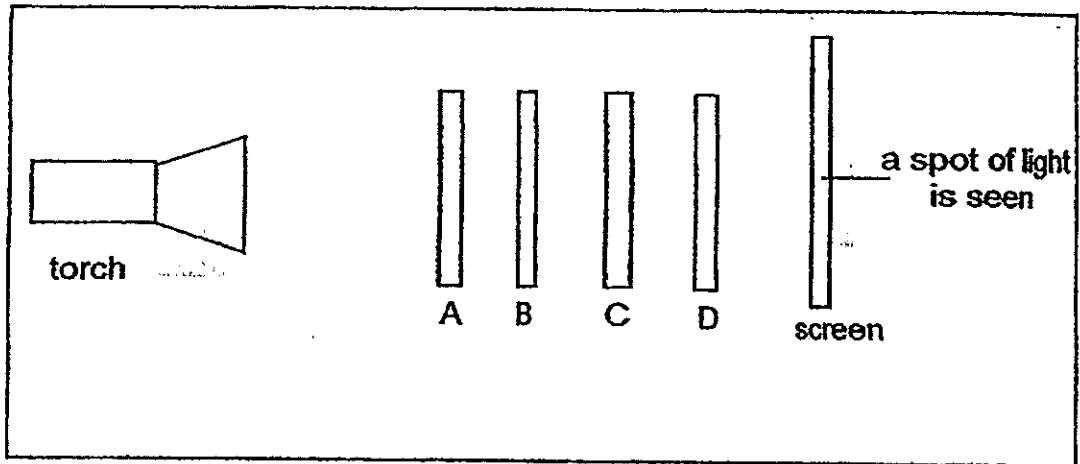

Based on the observations above, which one of the following could Materials A, B, C and D represent?

	A	B	C	D
(1)	wood	clear plastic	clear plastic	copper
(2)	copper	wood	clear plastic	clear glass
(3)	wood	clear plastic	copper	clear glass
(4)	clear glass	clear plastic	wood	copper

(Go on to the next page)

29. Ravi carried out an experiment as shown in the following diagram. A cool tilted metal tray was brought near the cup of water and water droplets were observed as shown.

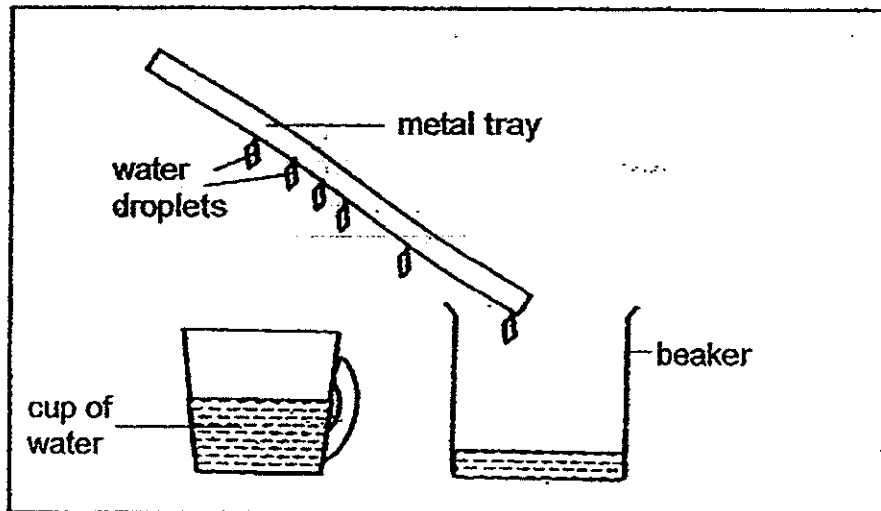

A few students made some statements based on the experiment.

Ai Ai: The water in the cup must be hot.

Belle: There will be less water droplets on the metal tray overtime.

Chris: The volume of water in the beaker will be more than the cup overtime.

Doris: There is a change of state for water as the water droplets drip into the beaker.

Which of the statement(s) made by the students is/are correct?

- (1) Ai Ai
- (2) Ai Ai and Belle
- (3) Chris and Doris
- (4) Belle and Doris

(Go on to the next page)

30. The graph below shows the level of carbon monoxide along Shenton Way at different times of the day.

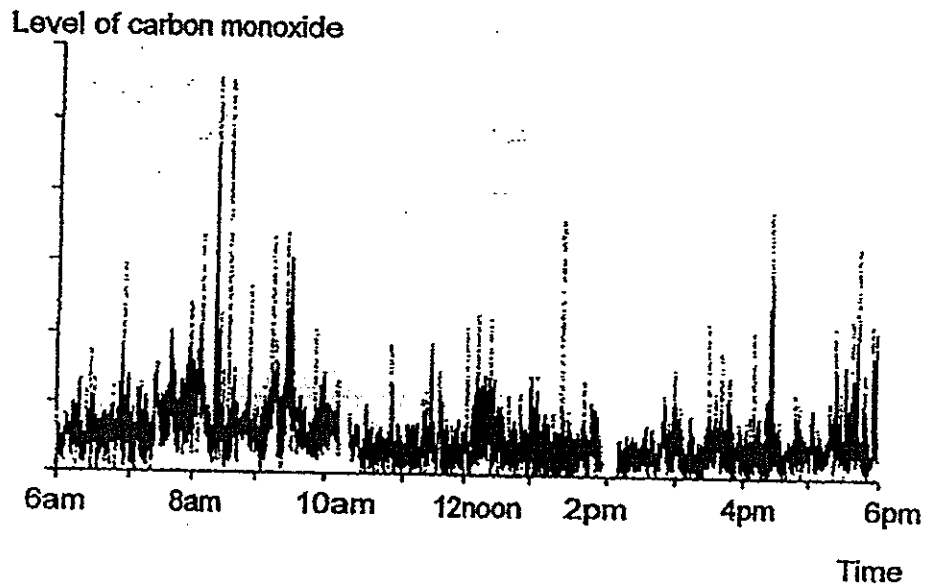

Which one of the following actions will result in a reduction in the level of carbon monoxide along Shenton Way?

- (1) Placing more traffic light junctions along the road.
- (2) Cutting down some trees along Shenton Way.
- (3) Widening Shenton Way to allow more lanes for cars to travel.
- (4) Encouraging commuters to use public transport instead of driving.

METHODIST GIRLS' SCHOOL

Founded in 1887



PRELIMINARY EXAMINATION 2014 PRIMARY 6 SCIENCE

BOOKLET B1

Total Time for Booklets A and B: 1 hour 45 minutes

INSTRUCTIONS TO CANDIDATES

Follow all instructions carefully.

Answer all questions.

Write your answers in this booklet.

Name: _____ ()

Class: Primary 6. _____

Date: 28 August 2014

Booklet A	/ 60
Booklet B1	/ 20
Booklet B2	/ 20
TOTAL	/ 100

This booklet consists of 8 printed pages including this page.

For questions 31 to 37, write your answers in the spaces provided. The number of marks available is shown in brackets [] at the end of each question or part question.

[20 marks]

31. Flamingos spend a lot of time looking for food in cold and shallow water.

The picture below shows a flamingo standing on one leg with the other leg tucked under its body in water.



- (a) Explain why the flamingo tucks its leg under its body when it is in water. [1m]

- (b) The flamingoes have beaks with a distinctive downward bend which allow them to feed on small organisms in shallow water. Sometimes, they even bury their entire heads in water to look for food near the bottom of the water.

Based on the picture only, describe another structural adaptation that enhances the flamingo's ability to look for food. [1m]

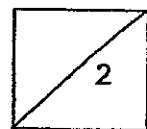

(Go on to the next page)

32. The food web below shown in the diagram shows the relationship between some organisms in a forest in Britain.

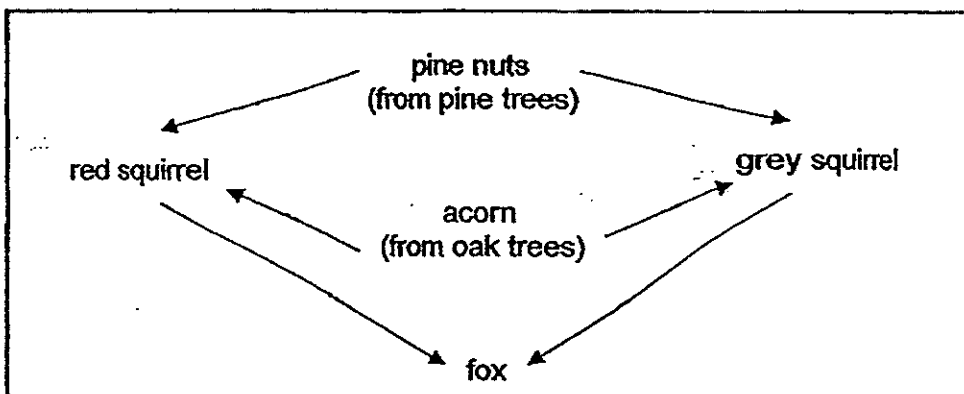

Red squirrels are native to the forests of Britain but American grey squirrels are introduced to Britain.

- (a) In the graph below, draw a dotted line to show the change in the red squirrel population from the time the grey squirrels were introduced. [1m]

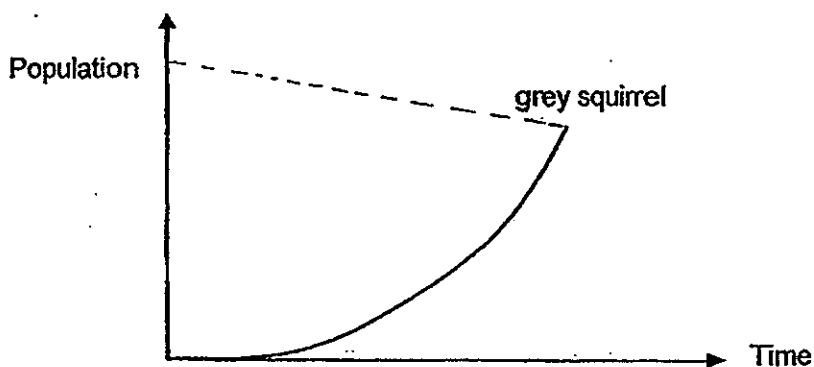

- (b) Give an explanation for your answer in (a). [1m]

- (c) Many pine trees were cut for their wood. How would this affect the population of the foxes? [1m]

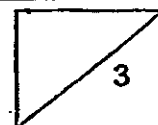

(Go on to the next page)

33. Study the flower as shown below.

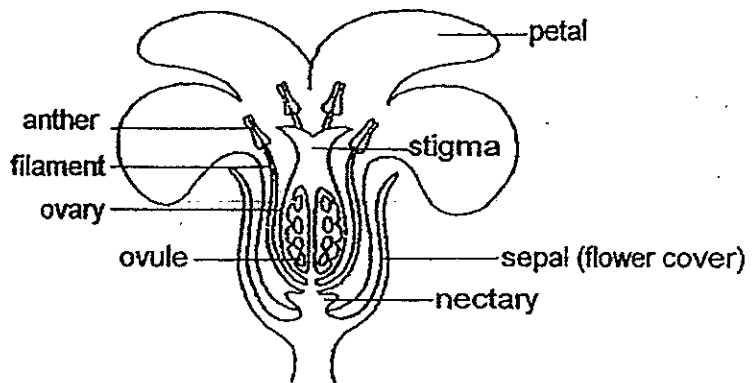

(a) What is the likely agent for pollination? Give a reason for your answer. [1m]

(b) Describe how the pollen grains are transferred from the anther to the stigma. [1m]

(c) Assuming the agent of pollination remains the same, how would the process of pollination be affected if the petals of the flower are cut off? [1m]

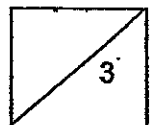

(Go on to the next page)

34. Mr Singh set up an experiment as shown in the diagram below. He placed a water snail of similar size in each test tube. Then he put the same amount of water plant in test-tubes A and C. Test-tubes A and B were left near the window exposed to sunlight while test-tubes C and D were kept in a black box.

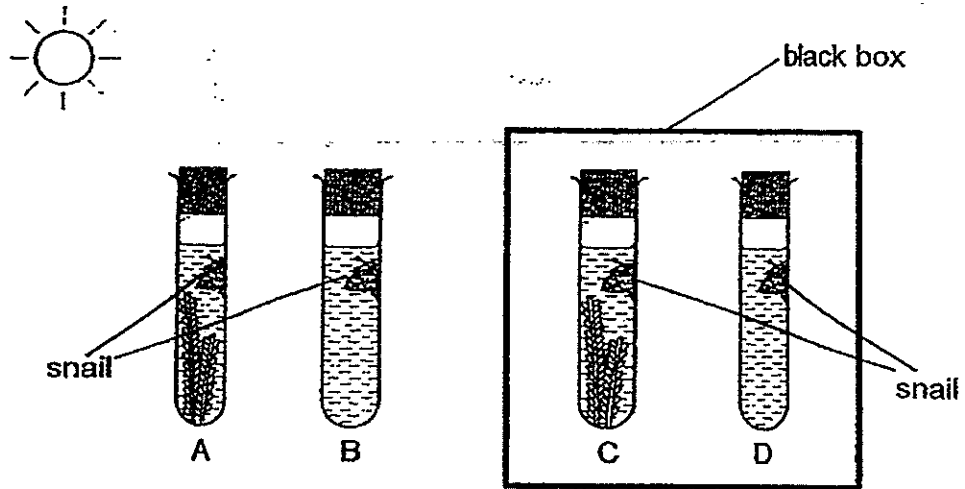

In which test-tube will the water snail survive the longest? Explain your answer. [2m]

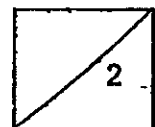

(Go on to the next page)

35. The fennec and arctic foxes have special adaptations to live in the hot desert environment and cold polar region respectively.



Fennec fox in desert



Arctic fox in polar region

(a) How are the ears of the fennec fox and arctic fox adapted to help the animals maintain their body temperatures in their respective habitats? [2m]

(b) Arctic foxes change the colour of their fur with the seasons. In winter, they are white while in the summer, they change to brown. How does this structural adaptation help the arctic fox to survive? [2m]

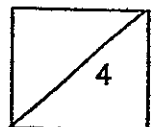

(Go on to the next page)

36. David started recording his pulse rate after skipping for two minutes by using a digital device. He continued skipping for some time before stopping. He then walked briskly to cool down. After that, he stopped and rested. The graph below shows the variation of his pulse rate.

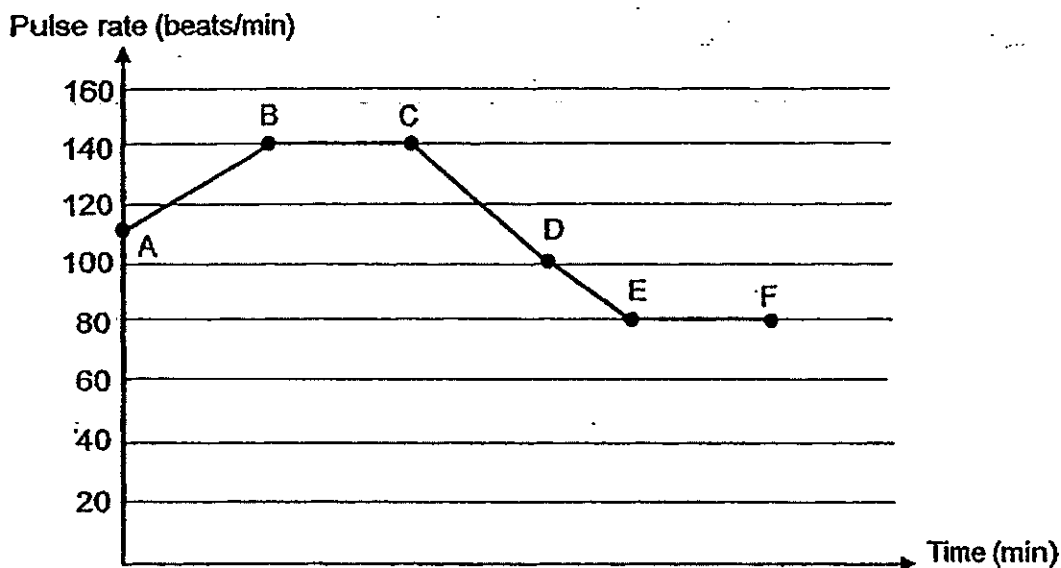

Answer the following questions based on the graph above.

- (a) If David was skipping between points A and B, suggest a reason for the increase of his pulse rate. [1m]

- (b) At which point did David stop skipping? Explain your answer. [1m]

- (c) What is David's pulse rate at rest? Explain why. [1m]

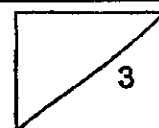

(Go on to the next page)

37. The diagram below shows three different types of cells.

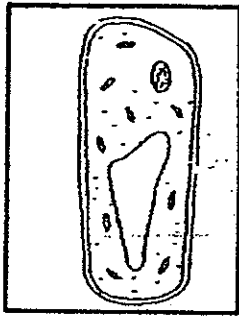

Cell X

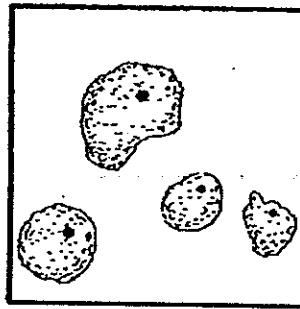

Cell Y

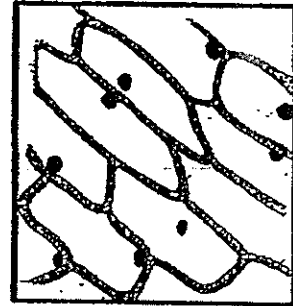

Cell Z

(a) Classify Cell X, Y and Z in the chart given below.

[1m]

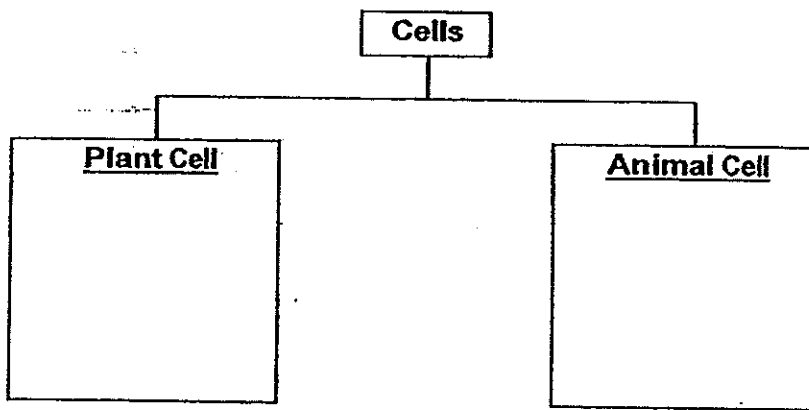

(b) Explain your answer in (a).

[1m]

(c) Which of the cells is likely to be taken from an onion? Explain your answer. [1m]

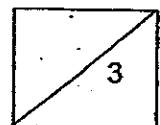

METHODIST GIRLS' SCHOOL

Founded in 1887



PRELIMINARY EXAMINATION 2014 PRIMARY 6 SCIENCE

BOOKLET B2

Total Time for Booklets A and B: 1 hour 45 minutes

INSTRUCTIONS TO CANDIDATES

Follow all instructions carefully.

Answer all questions.

Write your answers in this booklet.

Name: _____ ()

Class: Primary 6. _____

Date: 28 August 2014

Booklet B2	/ 20
-------------------	-------------

This booklet consists of 9 printed pages including this page.

38. The diagram below shows a pile driver used in a construction site. The hammer was raised to a height above the pile before it was released to drive the pile into the ground.

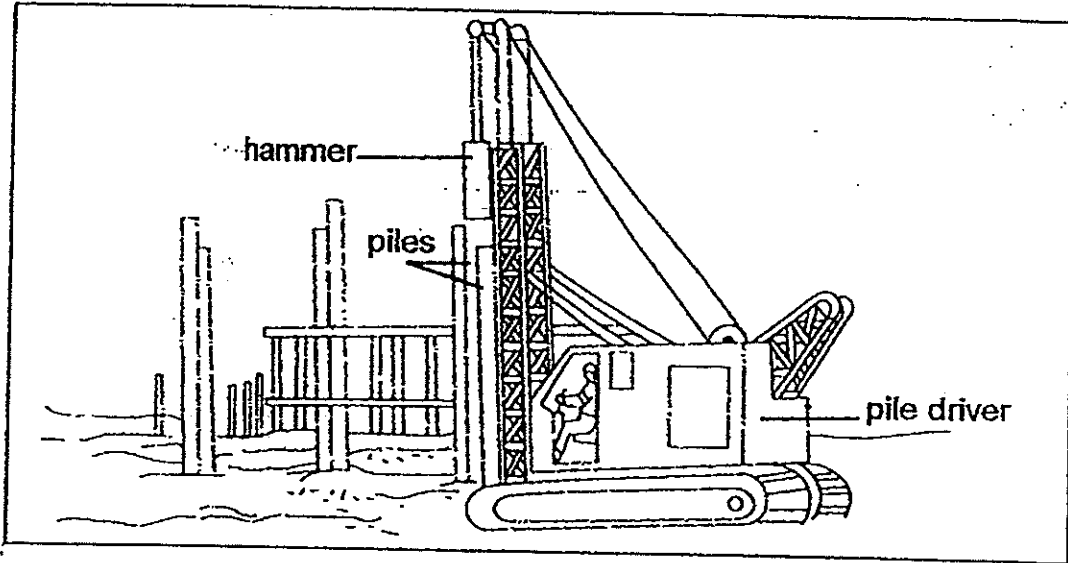

- (a) In the boxes below, write down the energy conversions which occur when the steel pile was driven into the ground. [2m]

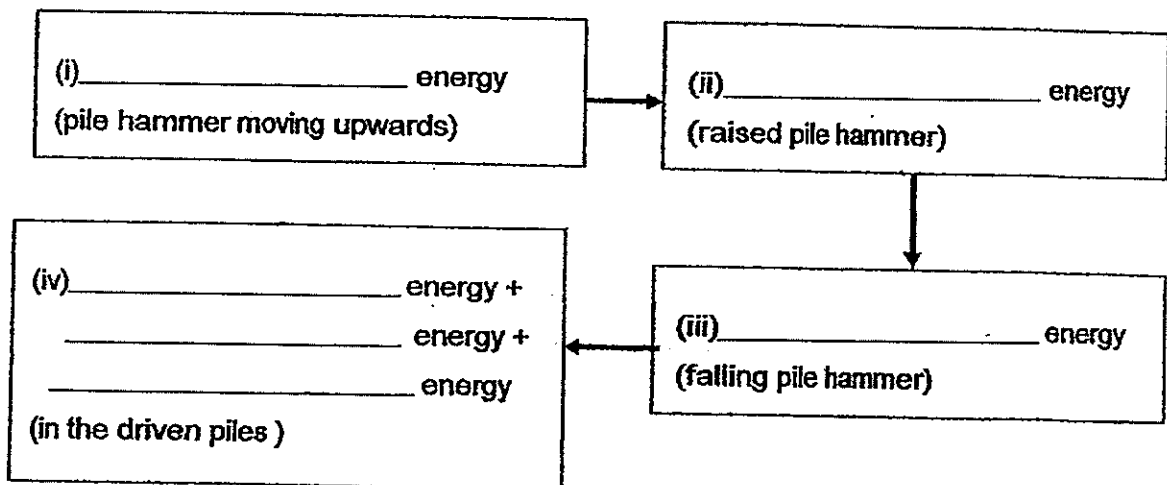

- (b) In order to meet the deadline of a construction project, Mr Rajan needs to complete the project as soon as possible. What should he do to drive the piles into the ground faster? [1m]

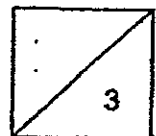

(Go on to the next page)

39. Leela prepared the set up as shown in the diagram below. The spring balance and iron core with coils are fixed in their positions

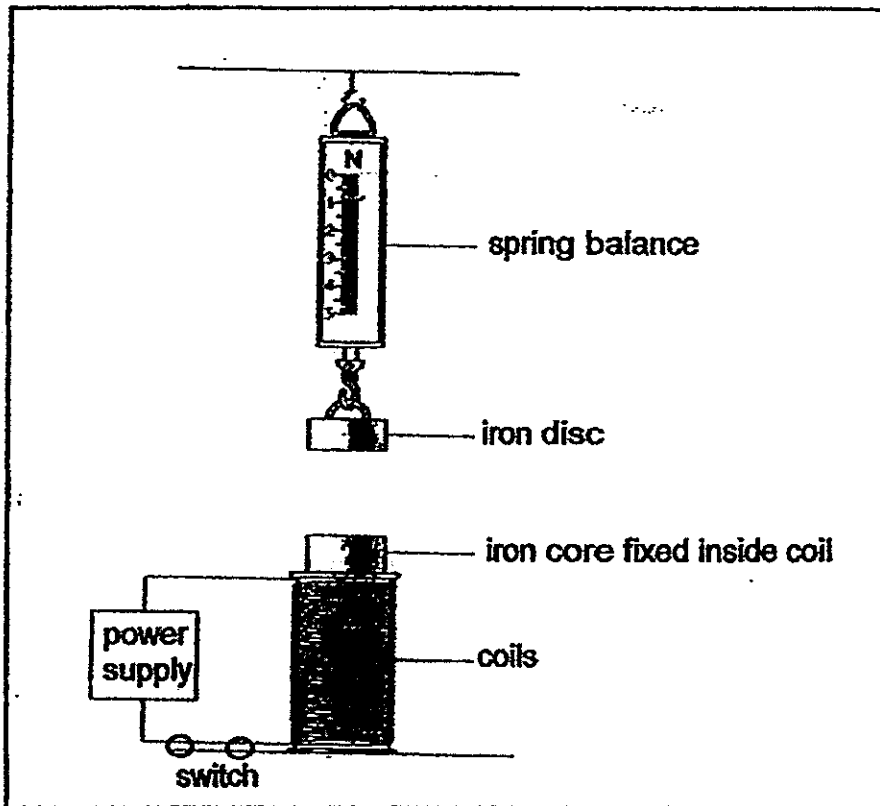

- (a) Explain what will happen when the power supply is switched on? [2m]

- (b) Without changing the iron disc, suggest one modification that should be made to the set up in order to increase the reading on the spring balance. [1m]

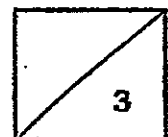

40. Mr Tan observed that in most café, hot drinks are served in a cup with a cup sleeve. The cup sleeve is made of jagged corrugated cardboard wrapped around a cup of hot drink as shown in the diagram below.

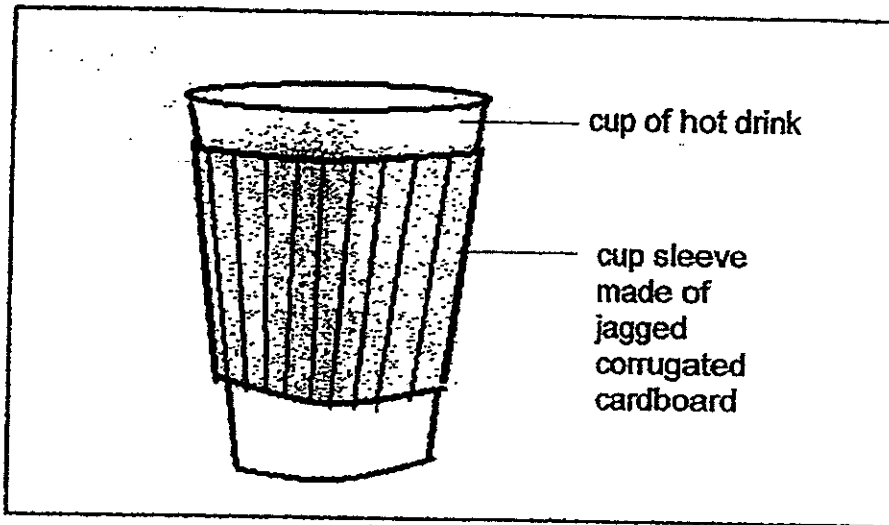

Explain clearly how the cup sleeve enabled Mr Tan to hold a cup of hot drink comfortably. [2m]

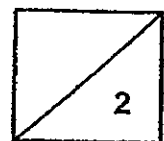

41. Baheeja set up the following experiment as shown in the diagram below. Similar balloons were placed inside each bottle in Set-ups A and B with its opening stretched over the mouth of the bottle.

Ten minutes later, she observed that the balloon in set-up B had become more inflated with air compared to the balloon in set-up A.

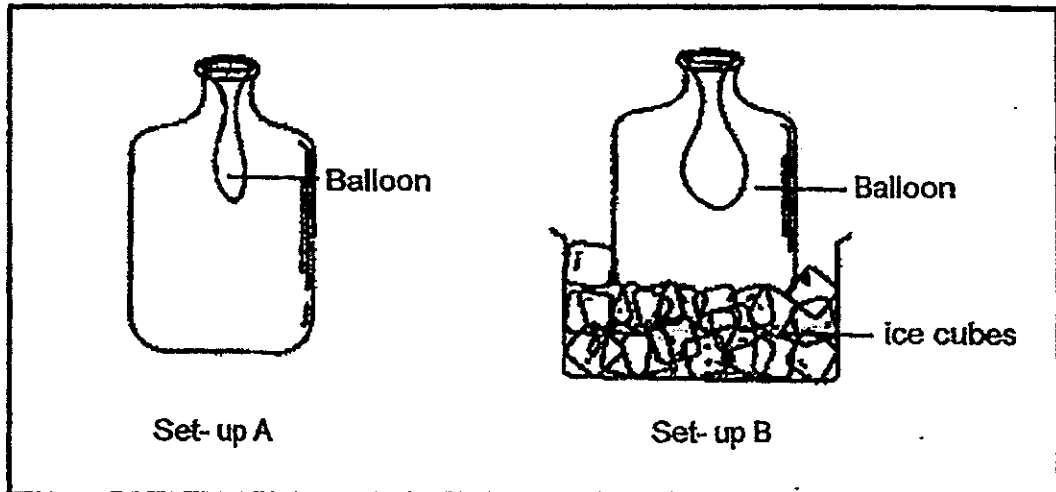

- (a) Explain why the balloon in set-up B became more inflated than the balloon in set-up A? [2m]

- (b) What is the purpose of Set-up A? [1m]

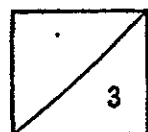

(Go on to the next page)

42. The graphs below show the average global temperature over the years and the average percentage of carbon dioxide in the atmosphere.

Average global temperature/ °C

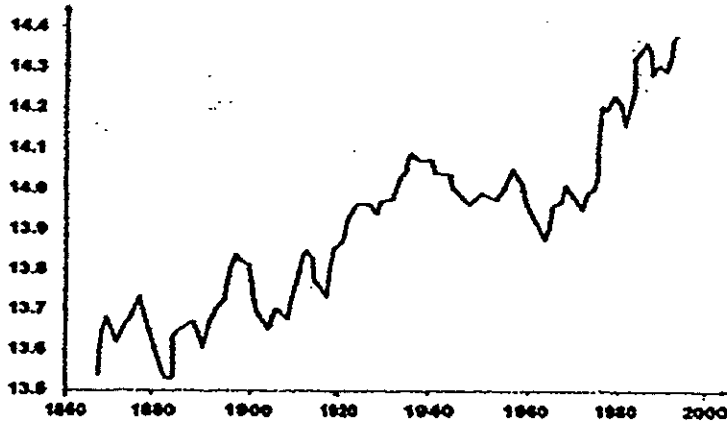

Percentage of carbon dioxide in the air

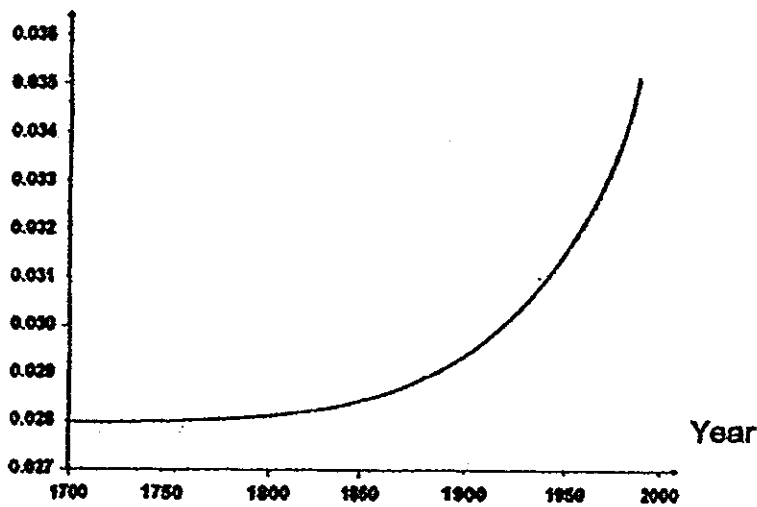

(a) Why does an increase in the percentage of carbon dioxide in the atmosphere lead to an increase in average global temperature? [1 ½ m]

(b) Explain how reforestation could reduce average global temperature in the long run. [1 ½ m]

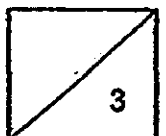

(Go on to the next page)

43. May set up an electrical circuit as shown in Diagram 1. The three objects, A, B and C were made of different materials. She noticed that when she turned on two switches at the same time, only some bulbs were lighted up.

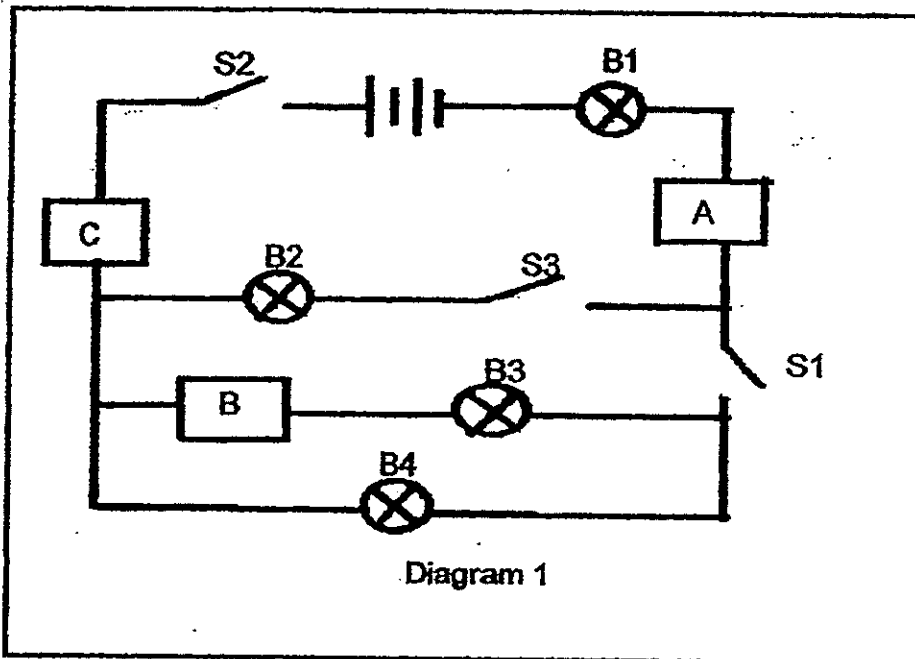

The table below shows the combination of switches that were turned on and the bulbs that were lighted up respectively.

Switches turned on	Bulbs lighted up
S1, S2	B1, B4
S2, S3	B1, B2

- (a) Which two out of the three objects, A, B and C are conductors of electricity? [1m]

- (b) May wanted to place a buzzer in the circuit so that when she closes switches S2 and S3, the buzzer will ring. In Diagram 1 above, indicate with an "X" to show where May should place the buzzer. [1m]

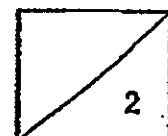

(Go on to the next page)

44. Jason prepared the following set-up. He wanted to investigate if the distance between the material and the light source would affect the reading of the amount of light reflected.

He carried out the experiment as shown in the diagram below by varying the distance between the material and the light source each time.

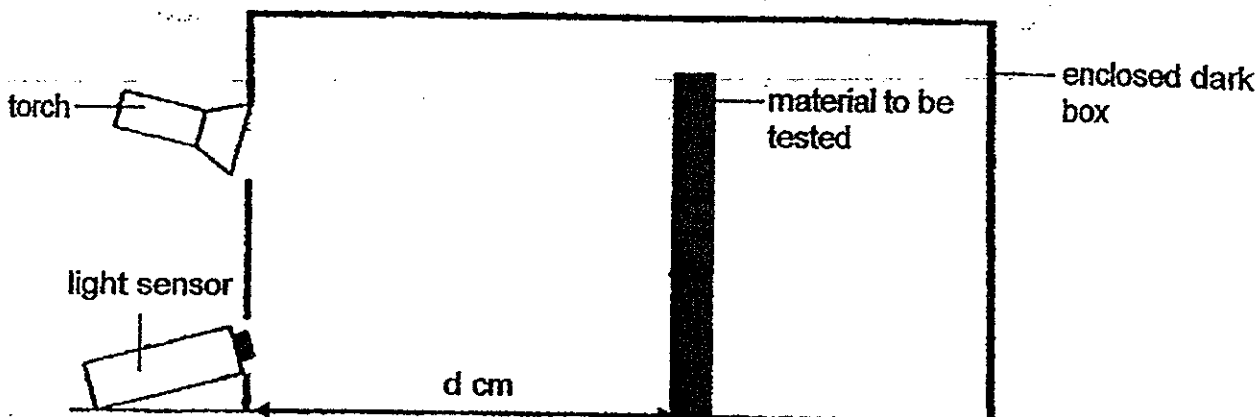

Jason performed the experiment using Material W, X, Y and Z and recorded his observations in a table shown below.

Distance(d cm)	Amount of light reflected (Lux)			
	Material W	Material X	Material Y	Material Z
10	280	285	150	170
20	190	240	100	140
30	120	200	90	100
40	70	100	50	40

- (a) In the diagram above, draw arrowed lines to show the path of light travelling from the torch to the light sensor. [1m]
- (b) Jason conducted the experiment in an enclosed dark box. His teacher told him that he has conducted a fair test. Explain why. [1m]

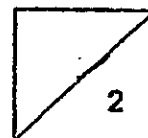

(Go on to the next page)

- (c) Other than conducting the experiment in a dark box as mentioned in (b), name 2 other variables that should be kept constant in order to ensure a fair test. [1m]

- (d) Based on his recordings given in the table above, which material would be the most suitable for making a safety vest? Give a reason for your answer. [1m]

End of Paper

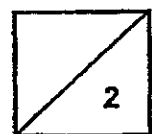

ANSWER SHEET

EXAM PAPER 2014

SCHOOL : MGS

PRIMARY : P6

SUBJECT : SCIENCE

TERM : SA2

Q1	Q2	Q3	Q4	Q5	Q6	Q7	Q8	Q9	Q10	Q11	Q12	Q13	Q14	Q15	Q16	Q17
2	3	1	3	1	2	4	3	2	2	1	4	4	3	1	2	2

Q18	Q19	Q20	Q21	Q22	Q23	Q24	Q25	Q26	Q27	Q28	Q29	Q30
2	4	1	4	3	3	3	4	3	1	2	2	4

31)a)The feathers trap air which is a poor conductor of heat and so the leg tucked under its body loses heat slower.

b)Their long necks enable them to stick their head deep in the water to search for food.

32)a)

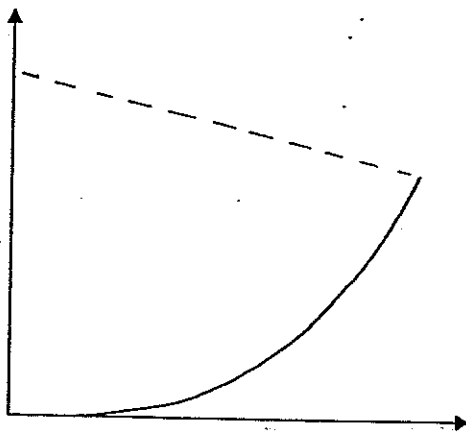

32)b)The grey squirrel competes with the red squirrels for food this reduces the amount of food for the squirrel, therefore the decrease in its population.

c)As the squirrels eat the pine nuts from pine trees, the population of the squirrels will decrease when the pine trees are cut and the fox preys on the squirrels therefore the fox population will also decrease.

33)a)The likely agent is by insects. As the flower has nectar.

b)Insects will be attracted by the colour of the flower and its nectar, when the insect goes onto the flower, it will get pollen grains on its body, then transferring the pollen grains onto the stigma.

c)Cutting the petals will not affect pollination.

34)A. In A, there is a plant which can provide oxygen for the water snail takes in carbon dioxide. The plant is exposed to sunlight, thus it can make food and give oxygen for the water snail.

35)a)The ears of the Fennec fox are large as in the desert, it is very hot and the large ears help to reduce the heat with its large exposed surface area. The arctic fox has small ears have smaller surface area to reduce heat loss as in the polar region.

b)This enable it to camouflage better with its surroundings to prevent being spotted by prey easily. As in the winter, their surroundings are white. Hence, their fur is white to match the surrounding. In summer, its surroundings are brown. Hence its fur is brown to blend in with its surroundings.

36)a)He could have slapped more quickly.

b)C. After point C, his pulse rate decreased. This shows that he stopped doing vigorous activities and rested for a while.

c)80 beats per minute. As when his pulse rate became 80 beats per minute, it remained constant.

37)a)Plant Cell

Cell X

Cell Z

Animal Cell

Cell Y

b)As only plant cells have cell walls and cell X and Z both have cell membranes. Animal cells do not have cell wall and Y is the only one without one.

c)Z. Onions grow underground where sunlight cannot reach. Thus, there is no need for the onion to have chloroplast to make food. Cell Z, does not have chloroplast either. Therefore, Z is likely to be taken from an onion.

38)a)i)Kinetic ii)Gravitational Potential iii)Kinetic

iv)Kinetic, Sound, Heat

b)He should raise the pile hammer higher and then drive the piles in.

41)a)As the air inside the bottle of set-up B lost heat to the tubes, thus contracting taking up less space in the bottle, the surrounding air came in through the mouth of the bottle taking up the remaining space causing the balloon to inflate.

b)Set-up A acts as a control to confirm that the changes was due to the ice cubes and nothing else.

42)a)Carbon dioxide is a greenhouse effect, greenhouse effect takes place when heat from the sun is trapped on earth by the carbon dioxide hence increase the global temperature.

b)Reforestation will increase the number of trees, that takes in more carbon dioxide in the air, during photosynthesis. Carbon dioxide is a greenhouse gas, and so less heat would be trapped in the atmosphere.

43)a)A,C
b)

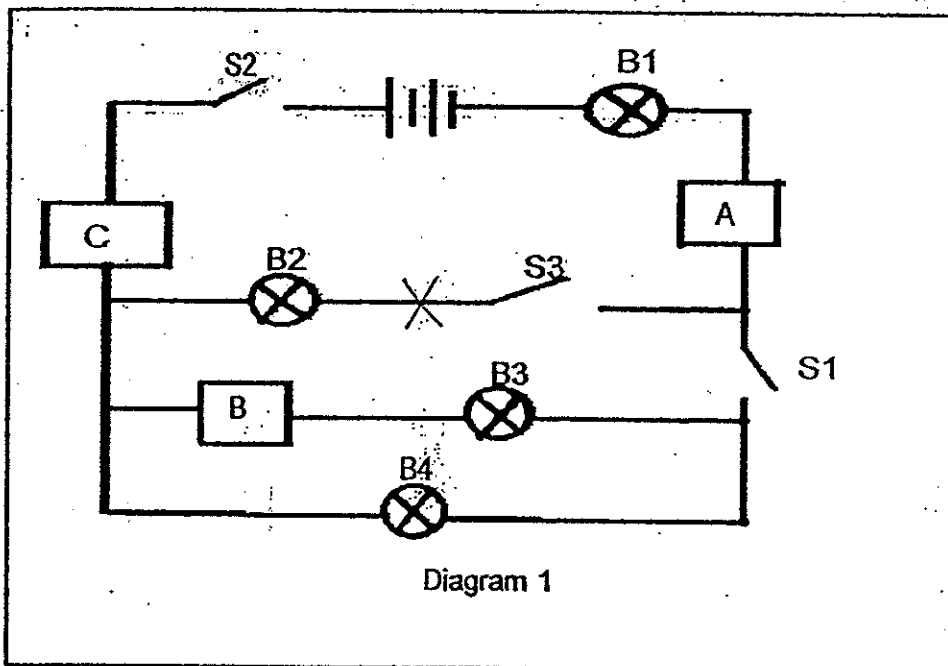

44)a)

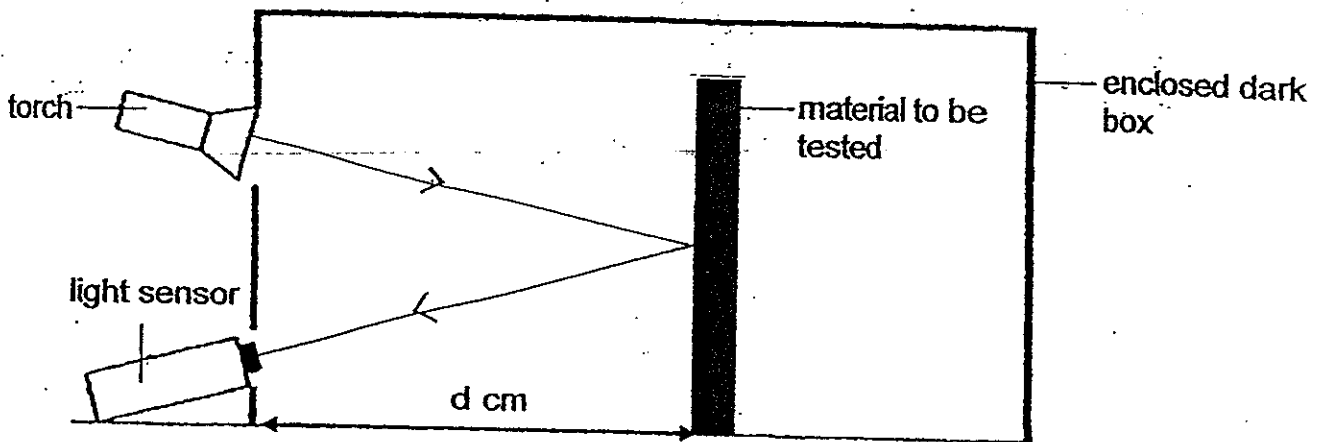

- b) He ensured that light from the surroundings would not affect the results.
- c) The thickness of the materials and the position of the light sensor.
- d) Material X. As it reflected the most of light and safety vest need to reflect light.