

**SINGAPORE CHINESE GIRLS' SCHOOL
FIRST SEMESTRAL ASSESSMENT 2013
PRIMARY 6 SCIENCE**

Name: _____ () Date: _____

Class: Primary 6 SY / C / G / SE / P

**SCIENCE
BOOKLET A**

30 questions

60 marks

Total Time For Booklets A & B: 1 h 45 min

**DO NOT OPEN THIS BOOKLET UNTIL YOU ARE TOLD TO DO SO.
FOLLOW ALL INSTRUCTIONS CAREFULLY.**

Part I (60 marks)

For each question from 1 to 30, four options are given. One of them is the correct answer. Make your choice (1, 2, 3 or 4). Shade the correct oval (1, 2, 3 or 4) on the Optical Answer Sheet.

1. The following are the characteristics of Organism X.
- Can swim
 - Warm blooded
 - Have backbone

Which of the following is most likely to be Organism X?

- 1) Frog
2) Penguin
3) Shark
4) Crocodile

2. Which of the following chart/s is/are suitable for classifying ferns and fungi?

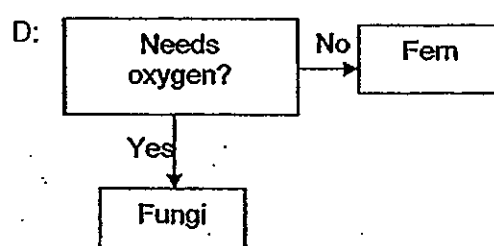
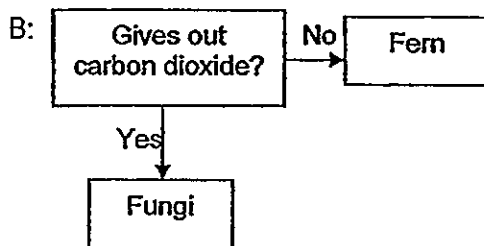
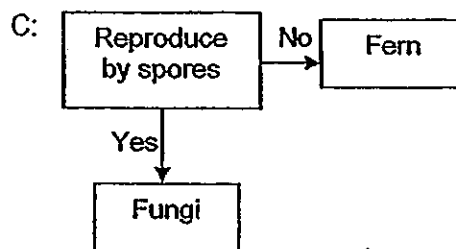
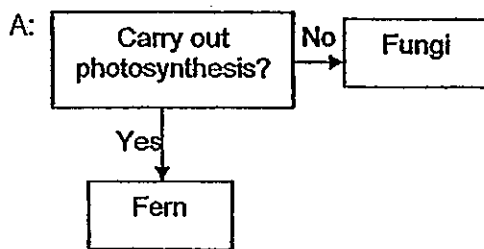

- 1) A only
2) A and C only
3) B and D only
4) A, B and D only

3. Which of the following correctly shows the path that food takes in the human digestive system?

- 1) Mouth → gullet → stomach → large intestine → small intestine → anus
2) Mouth → gullet → stomach → small intestine → large intestine → anus
3) Mouth → windpipe → stomach → small intestine → large intestine → anus
4) Mouth → windpipe → stomach → large intestine → small intestine → anus

4. Study the flow chart below.

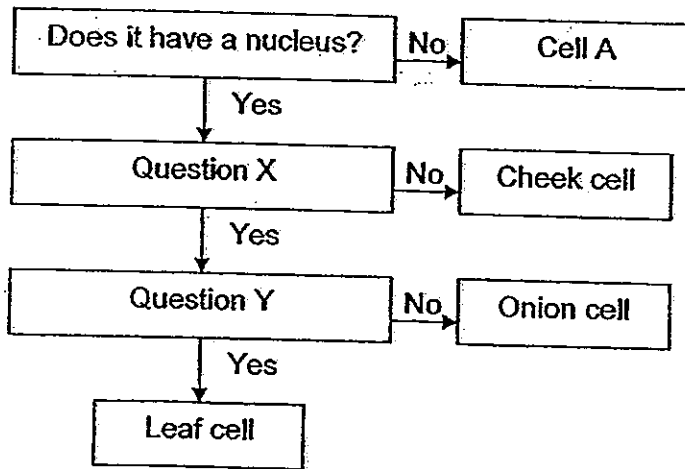

Which of the following correctly shows Question X and Question Y?

	Question X	Question Y
1)	Does it have cell membrane?	Does it have cell wall?
2)	Does it have chloroplast?	Does it have cytoplasm?
3)	Does it have cytoplasm?	Does it have cell membrane?
4)	Does it have cell wall?	Does it have chloroplast?

5. The diagram below shows the magnified image of part of a leaf. Which of the following are the functions of the part labelled X in the diagram below?

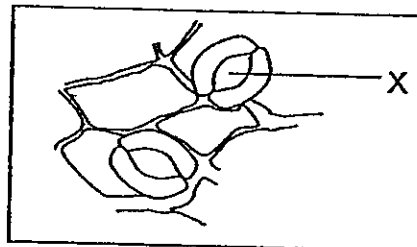

A: Trap sunlight
B: Take in oxygen

C: Take in carbon dioxide
D: Make food for the plant

1) A and C only
2) B and C only

3) B, C and D only
4) A, B, C and D

6. W, X, Y and Z in the diagram below represent the blood vessels in the human body.

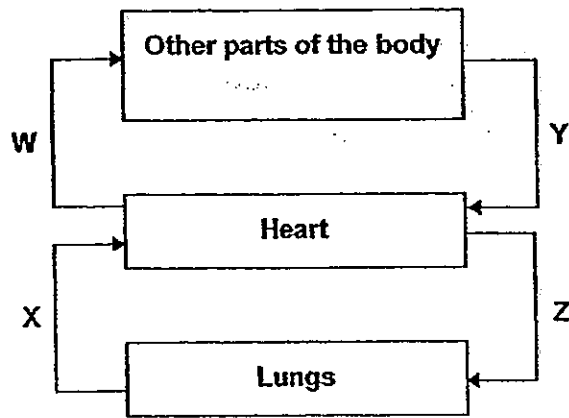

The graph below shows the concentration of carbon dioxide in 4 blood samples taken from different blood vessels in the human circulatory system.

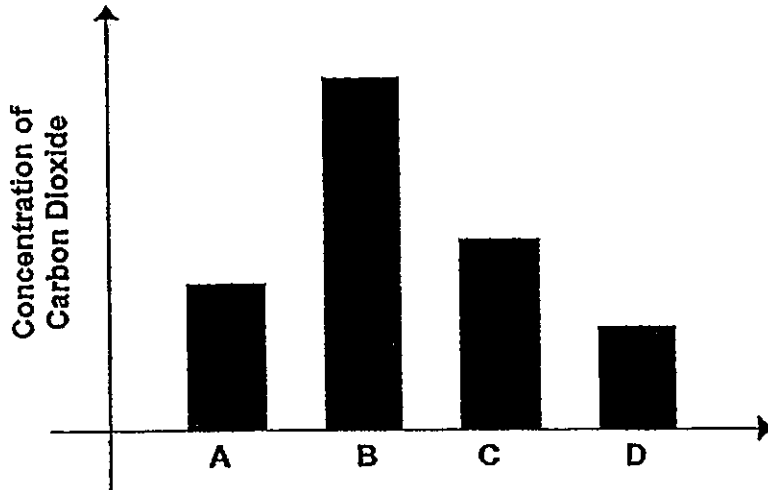

Which sample is most likely to be taken from the blood vessel Z?

- 1) A
- 2) B
- 3) C
- 4) D

7. Lynn used a circuit tester to test the circuit card below.

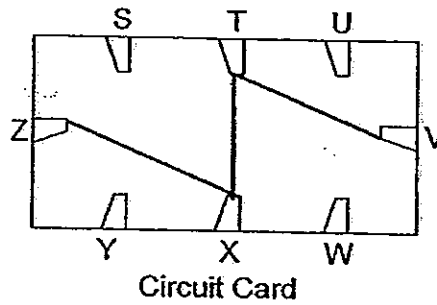

Which one of the following table below correctly shows the results of her test?

1)

Clips tested	Did the bulb light up?
S and T	No
T and X	Yes
U and W	No
V and Z	No
W and Z	No
T and Z	Yes

3)

Clips tested	Did the bulb light up?
S and Z	No
T and V	No
U and V	Yes
V and T	Yes
W and Y	No
X and Y	No

2)

Clips tested	Did the bulb light up?
S and U	No
T and V	Yes
U and W	Yes
V and X	Yes
W and Z	No
X and S	No

4)

Clips tested	Did the bulb light up?
S and T	No
T and U	No
U and V	No
V and X	Yes
W and Y	No
X and Z	Yes

8. The table below shows the conditions of 4 different habitats.

	Habitat			
	W	X	Y	Z
Amount of light	Low	High	Low	High
Amount of moisture	Low	High	High	Low
Temperature	17°C	28°C	32°C	24°C

Which of the habitats is the most suitable for the growth of bread mould?

- 1) W
2) X

- 3) Y
4) Z

9. Substance P is given out by Organism Q. Ming Hua measured the amount of Substance P at 3 different locations. He also counted the number of Organism Q found in each location and recorded the information in the table below.

Location	Amount of Substance P	Number of Organism Q
X	15g	37
Y	24g	64
Z	9g	11

Based on the information in the table above, what can Ming Hua conclude about the relationship between the number of Organism Q and the amount of Substance P?

- 1) The lower amount of Substance P resulted in the smaller number of Organism Q.
- 2) The higher amount of Substance P resulted in the greater number of Organism Q.
- 3) The smaller number of Organism Q resulted in the higher amount of Substance P.
- 4) The greater number of Organism Q resulted in the higher amount of Substance P.

10. Study the food web below.

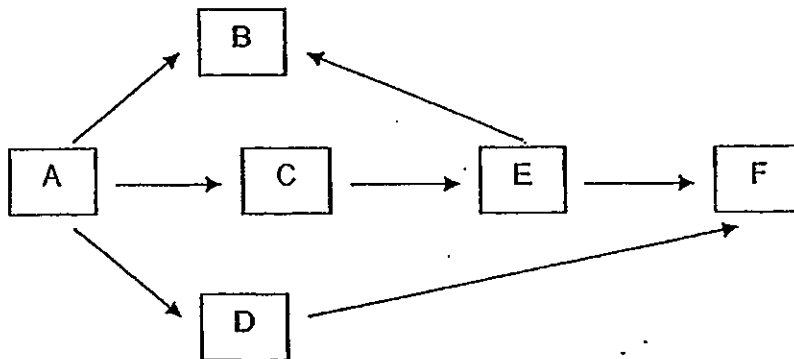

If all of the Organism C is removed from the food web, which organism will be the most greatly affected?

- 1) A
- 2) B
- 3) D
- 4) E

11. Which of the following adaptations and functions of birds have been matched correctly?

	Adaptations	Functions
A:	Feathers	Keep warm
B:	Webbed feet	Catch prey
C:	Hollow bones	Reduce body weight
D:	Streamlined body shape	Reduce frictional force during flight

- 1) A and C only
 2) B and D only
 3) A, C and D only
 4) A, B, C and D

12. The original length of Spring X and Spring Y was 5cm. After loads of various mass were hung on them, Tim recorded the extension of each spring and plotted the graph below.

Extension of spring (cm)

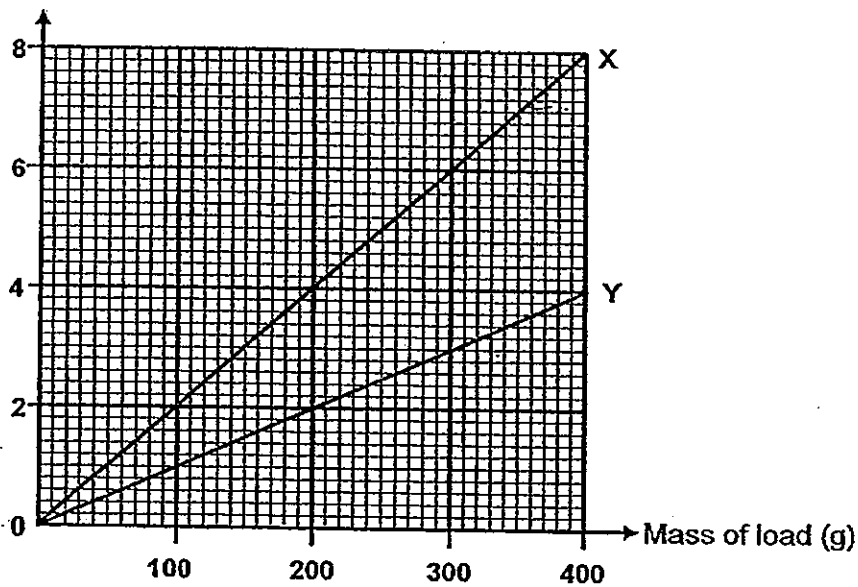

Which of the following correctly shows the length of each spring when a load of 200g was hung on each of them?

	Spring X	Spring Y
1)	2cm	4cm
2)	4cm	2cm
3)	9cm	7cm
4)	7cm	9cm

13. When the box is hung on the spring balance, the reading on the spring balance is 300g.

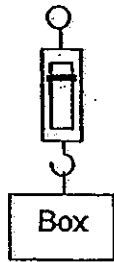

The same box is then hung on 2 similar spring balances. Which one of the following is the most likely reading of each of the spring balance?

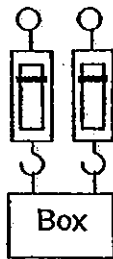

- 1) 150g
2) 300g
3) 450g
4) 600g

14. 2 balls moving in opposite directions collided with each other and moved in the direction as shown below.

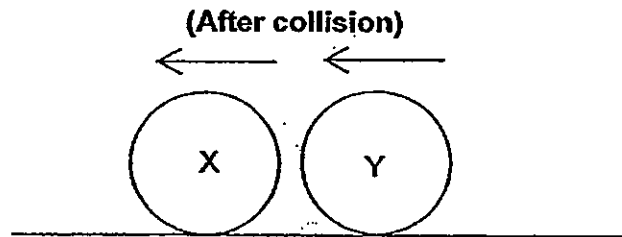

What one of the following is the most likely reason for both balls to be moving in the same direction after colliding with each other?

- 1) Ball Y has the same mass as Ball X.
2) Ball X has a greater mass than Ball Y.
3) Ball X was moving faster than Ball Y before the collision.
4) Ball Y was moving faster than Ball X before the collision.

15. The diagrams below show 4 magnets, A, B, C and D.
T repels X and Y. W repels V.

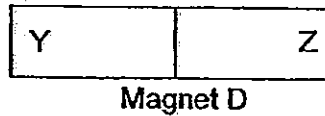
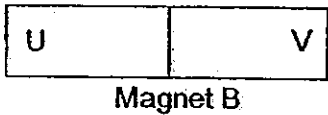
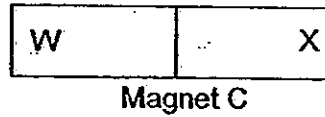
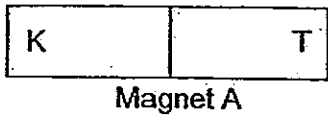

Which one of the following will attract each other?

- 1) K and U
2) W and Z
3) X and Y
4) V and Z
16. Which of the following is produced by the plant during photosynthesis?
- A: Water
B: Sugar
C: Starch
D: Oxygen
E: Carbon dioxide
- 1) A and E only
2) B and D only
3) A, C and D only
4) B, C and D only
17. Which of the following are possible shadows cast by the solid wooden object shown below?

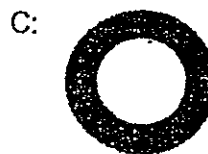
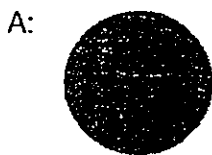
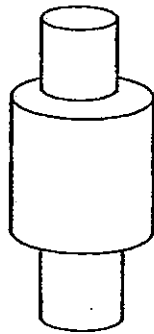

- 1) A and D only
2) B and C only

- 3) B, C and D only
4) A, B and D only

18. Alicia placed 2 metal cubes of the same temperature but different volumes into 2 pots of water.

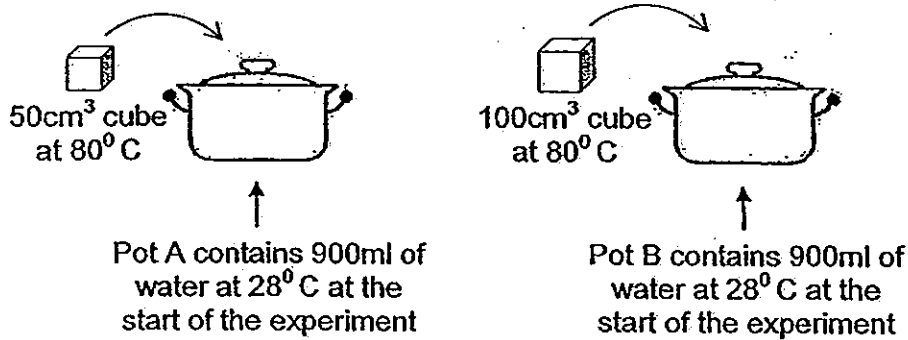

After 3 minutes, Alicia measured the temperature of water in each pot. What is the most likely result of Alicia's experiment?

	Observation	Reason
1)	The water in Pot A has a higher temperature than the water in Pot B.	The water in Pot A gained more heat.
2)	The water in Pot B has a higher temperature than the water in Pot A.	The water in Pot B gained more heat.
3)	Both pots of water will have the same temperature.	The amount of heat gained by both pots of water is the same as both cubes were placed in the water for the same duration.
4)	Both pots of water will have the same temperature.	The amount of heat gained by both pots of water is the same as both cubes were of the same temperature.

19. Minmin poured hot water into 2 cups made of the same size but of different materials. She measured the temperature of the water in each cup after 15 minutes. The results of her experiment are as shown in the table below.

Time	Temperature of water in the cup (°C)	
	Cup A	Cup B
0 mins	95	95
15 mins	60	89

Which material is the most suitable for making a container to transport ice and a container to keep food warm respectively?

	Material most suitable to make a container to transport ice	Material most suitable to make a container to keep food warm
1)	A	A
2)	A	B
3)	B	A
4)	B	B

20. Which one of the following correctly shows the main energy changes that will take place when a battery-operated fan is switched on?

- 1) electrical energy → potential energy → light energy
- 2) electrical energy → potential energy → heat energy
- 3) potential energy → electrical energy → kinetic energy
- 4) potential energy → kinetic energy → electrical energy

21. Sammy dropped a rubber ball from a height above the ground. Each time the rubber ball hit the ground, it bounced up but to a lower height.

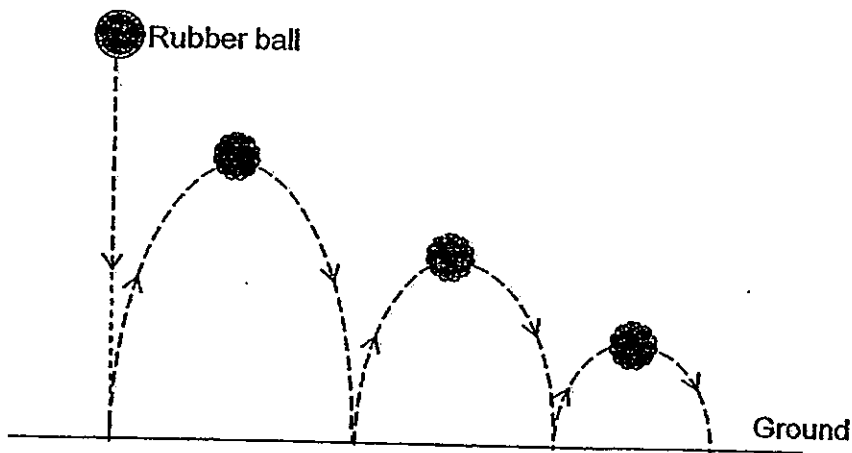

Which one of the following best explains the reason for the decreasing height?

- 1) Gravitational force was acting on the rubber ball.
- 2) Frictional force was acting against the rubber ball.
- 3) Some of the energy in the rubber ball was destroyed as the ball bounces.
- 4) Some of the energy in the rubber ball was converted to heat and sound energy.

22. Ali released a metal ball from Point A in a bowl. The metal ball could only reach Position X. If Ali wants the metal ball to reach Position Y, which of the following solution/s will enable it to happen?

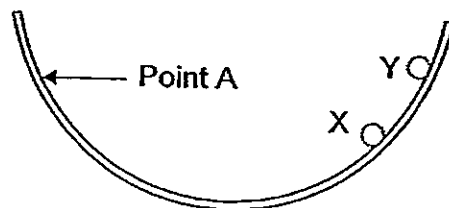

- A: Use a bigger metal ball.
- B: Use a smaller metal ball.
- C: Apply oil on the inner side of the bowl.
- D: Release the metal ball from a higher position.

- 1) D only
- 2) A and D only
- 3) B and C only
- 4) A, C and D only

23. Kumar carried out an experiment as shown below. He recorded the time taken for the ball to travel from X to Y after he released the ball at X.

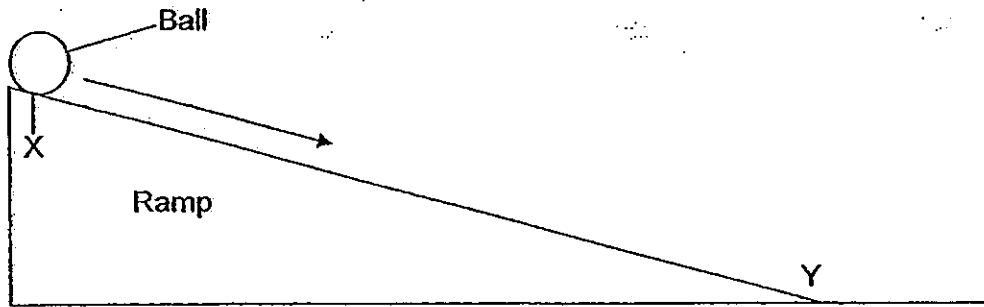

He then repeated the experiment 2 more times, each time only changing the height of the ramp.

Which of the following are possible aims of Kumar's experiment?

- A: To find out if the height of ramp affects the speed the ball travels.
- B: To find out if the height of the ramp affects the distance moved by the ball.
- C: To find out if the weight of the ball affects the distance travelled by the ball.
- D: To find out if the height of the ramp affects the time taken for the ball to travel.

- 1) D only
- 2) A and D only
- 3) B and C only
- 4) B and D only

24. Study the classification chart below. What do X and D represent respectively?

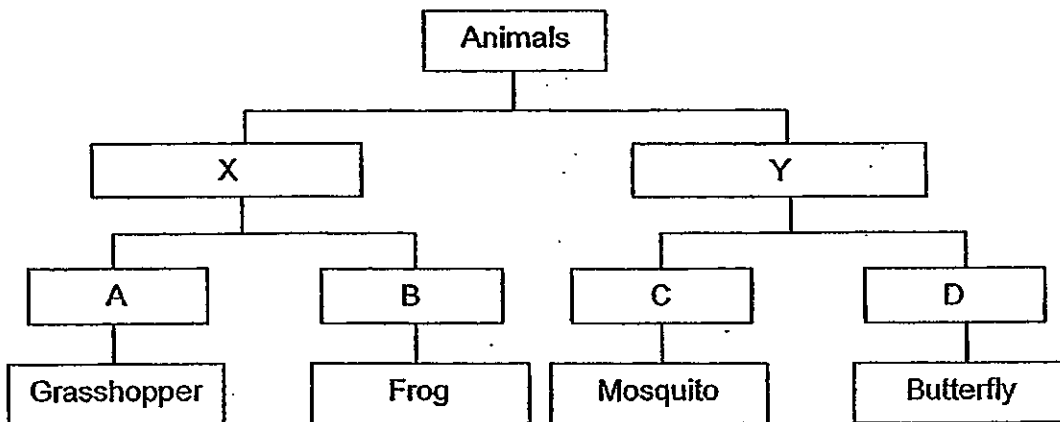

	X	D
1)	Cannot fly	Can fly
2)	Lay eggs in water	4 stages in life cycle
3)	3 stages in life cycle	Lay eggs on land
4)	Lay eggs on land	Lay eggs in water

25. The diagram below shows the life cycle of Organism P.

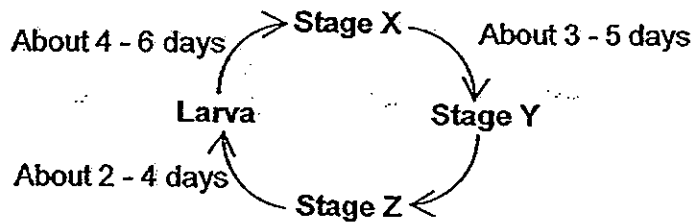

What is the least possible number of days Organism P can develop from a larva to the adult stage?

- 1) 6
- 2) 7
- 3) 9
- 4) 11

26. The diagram below shows the cross-section of a flower.

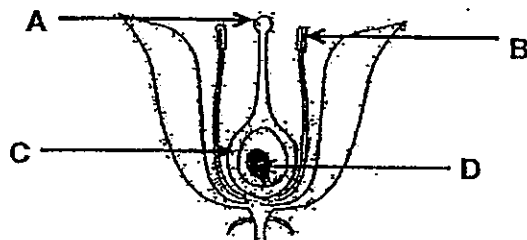

Which part/s of the flower are essential for pollination?

- 1) A only
- 2) D only
- 3) A and B only
- 4) C and D only

27. The diagram below shows Sam's family tree.

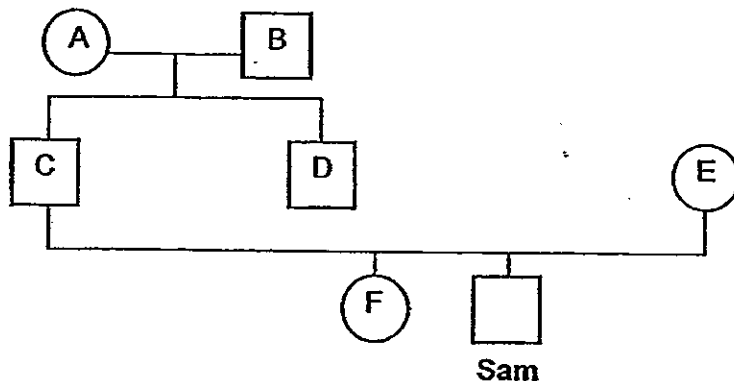

Sam has attached earlobes. Which of the following family members could have passed down this trait to him?

- 1) C and E only
- 2) B, C and D only
- 3) A, B, C and E only
- 4) A, B, C, D, E and F

28. A cup was inverted and lowered vertically into a basin of water. Which property/properties of air allow the water to enter the cup?

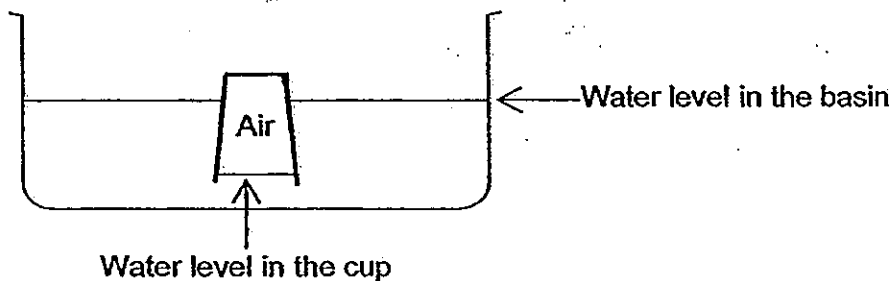

- A: Has mass
 B: Has a definite volume
 C: Can be compressed
 D: Has a definite shape

- 1) B only
 2) C only
 3) A and D only
 4) B, C and D only

29. The graph below shows the change in temperature of Substance S which was being heated from the solid state till it reached its boiling point.

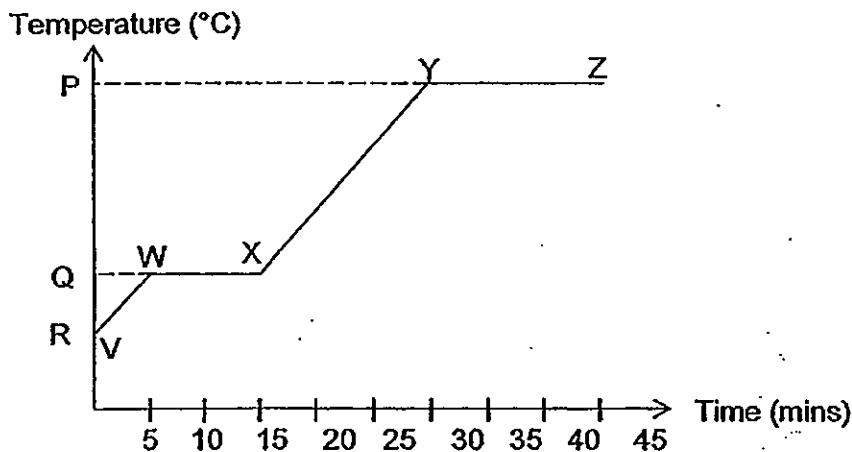

Based on the graph, which of the following statements are true?

- A: Substance S melted at $Q^{\circ}\text{C}$.
 B: $R^{\circ}\text{C}$ was the room temperature.
 C: Substance S started to boil at Point Y.
 D: Substance S started melting at Point V.

- 1) A and B only
 2) A and C only
 3) C and D only
 4) B, C and D only

30. Water exists in 3 states. The diagram below shows the water cycle.

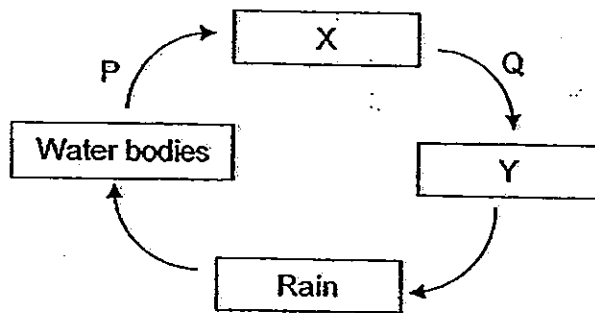

Which of the following statement/s about the diagram above is true?

- A: X represents water vapour.
- B: Y represents tiny water droplets.
- C: Water loses heat during Process P.
- D: Water gains heat during Process Q.

1) A only

2) A and B only

3) C and D only

4) B, C and D only

**SINGAPORE CHINESE GIRLS' SCHOOL
FIRST SEMESTRAL ASSESSMENT 2013
PRIMARY 6 SCIENCE**

Name: _____ () Date: _____

Class: Primary 6 SY / C / G / SE / P

Components	Marks Obtained	Total Marks
Booklet A		60
Booklet B		40
Total		100

_____ Parent's Signature

**SCIENCE
BOOKLET B**

14 questions

40 marks

Total Time For Booklets A & B: 1 h 45 min

DO NOT OPEN THIS BOOKLET UNTIL YOU ARE TOLD TO DO SO.

FOLLOW ALL INSTRUCTIONS CAREFULLY

Name: _____ ()
Class: Primary 6 SY/C/G/SE/P

Part II (40 marks)

Answer all the following questions.

31. Nathan conducted an experiment as shown in the diagram below.

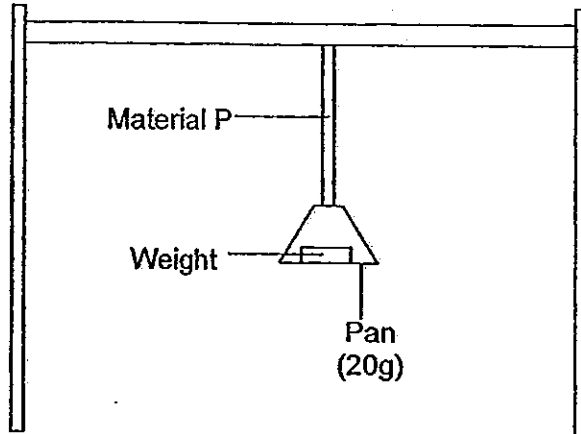

He wanted to test if adding Substance X to Material P will change the strength of Material P. He fixed Material P to a support and attached a pan to it. He then placed weights onto the pan until Material P breaks. He then repeated the experiment by adding Substance X to Material P. The table below shows the results of his experiment.

	Mass of weight added to the pan before Material P breaks
Material P without Substance X	141g
Material P with Substance X	108g

- a) Nathan said that the total mass needed to break Material P without Substance X is 141g. Do you agree with him? Explain your answer. (1m)

- b) Explain why keeping the width of Material P the same for each try will make it a fair test. (1m)

- c) What can Nathan conclude from his experiment? (1m)

32. Mrs Tan wanted to find out if the temperature of the surroundings will affect the rate plants take in water. She set up an experiment as shown below.

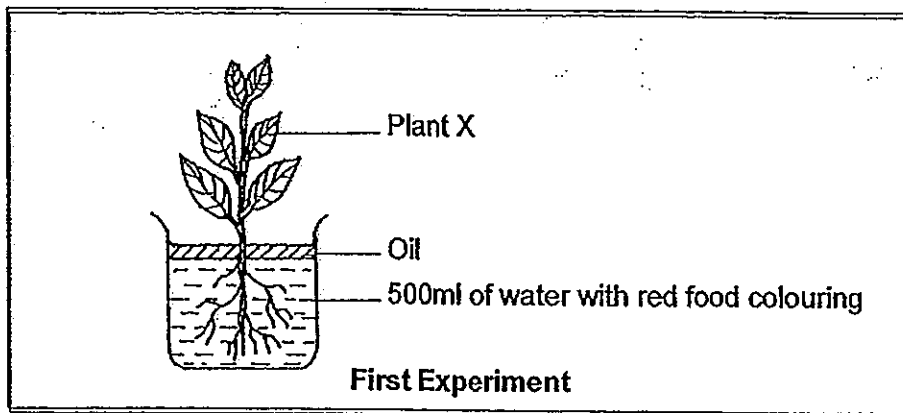

Mrs Tan added a layer of oil in the water and placed the set-up in a room of 35°C. Then she recorded the time taken for the top 2 leaves of the plant to turn red.

Immediately after the first experiment, Mrs Tan used the same plant and another beaker of water with blue food colouring. She placed the set-up in a room of 25°C. Then she recorded the time taken for the top 2 leaves of the plant to turn purplish blue.

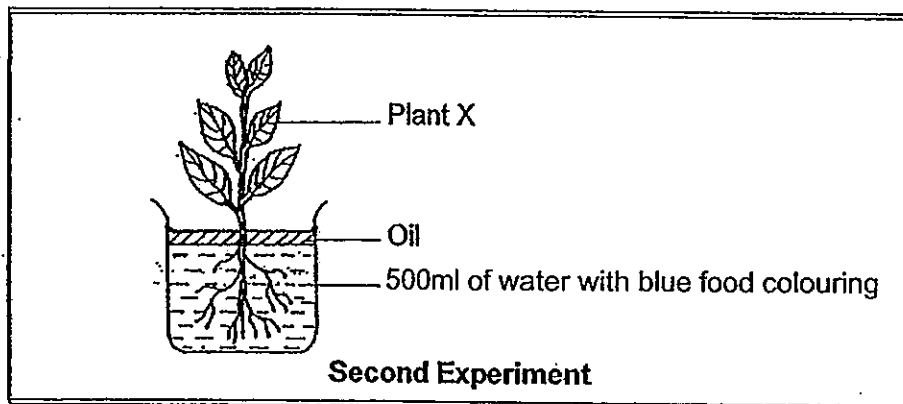

- a) Besides observing the time taken for the leaves of the plant to turn colour, state another observation Mrs Tan can make in her experiment in order to draw a conclusion? (1m)

- b) A friend told Mrs Tan that she should not have used the same plant for the experiment. Do you agree with her friend? Explain your answer. (1m)

33. Study the 4 circuits below.

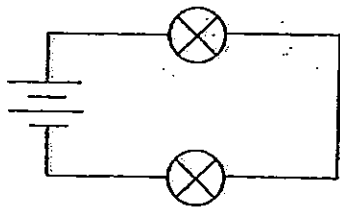

Set-up P

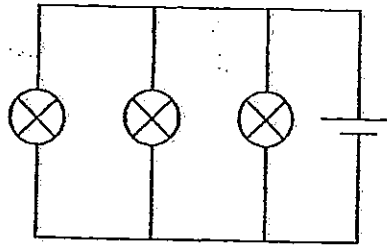

Set-up R

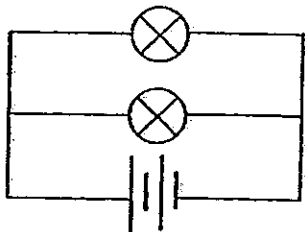

Set-up Q

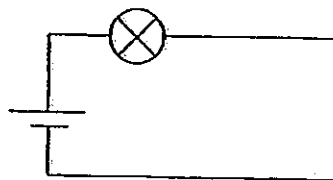

Set-up S

Based on the set-ups above, put a tick (✓) in the appropriate column to indicate if each of the following statement is 'True' or 'False'. (4m)

	Statements	True	False
a)	If one of the bulbs in Set-up R is fused, the other 2 bulbs will still light up.		
b)	Each bulb in Set-up Q is brighter than the bulb in Set-up S.		
c)	Each bulb in Set-up S is dimmer than the bulb in Set-up R.		
d)	The bulbs in Set-up P, Q and R are arranged in parallel.		

34. Muthu used the circuit below to conduct an experiment. He connected 6 different objects, P, Q, R, S, T and U to the circuit at positions A, B and C and recorded his findings in the table below.

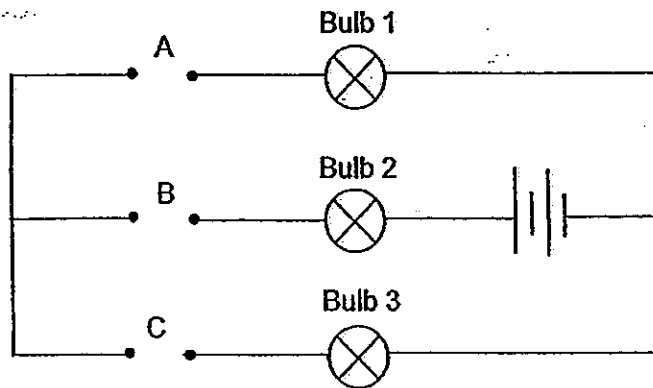

Objects placed at			Does the bulb light up?		
A	B	C	Bulb 1	Bulb 2	Bulb 3
P	Q	R	✓	✓	
S	R	T			
U	Q	P		✓	✓
T	P	S		✓	✓
Q	U	P			

- a) Which object/s is/are conductors of electricity? (1m)
-
- b) If a toothpick, magnet and glass rod are placed at A, B and C respectively, which of the bulb/s in the circuit will light up? (1m)

Objects placed at		
A	B	C
Toothpick	Magnet	Glass rod

35. The diagram below shows the food webs in 2 different habitats.

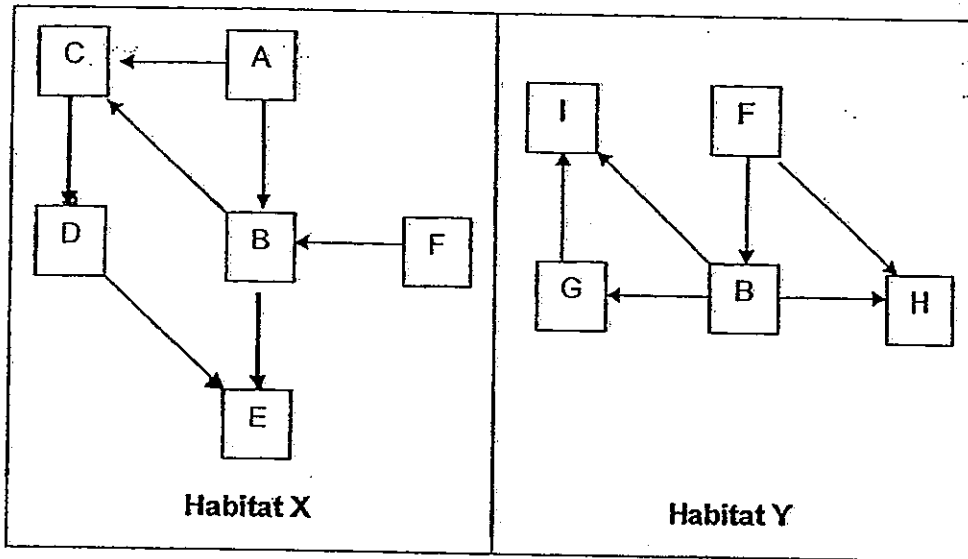

- a) How many food chains are there in Habitat X? (1m)

- b) In Habitat X and Habitat Y, what is the total number of organisms that are both a prey and a predator? (1m)

- c) Tom moved one of the animal populations from Habitat X to Habitat Y but it was unable to survive. Which animal population did he move? (1m)

- d) If Tom move Population H to Habitat X, will it be able to survive? Give a reason for your answer. (1m)

36. The diagram below shows the different zones of the ocean according to their depths.

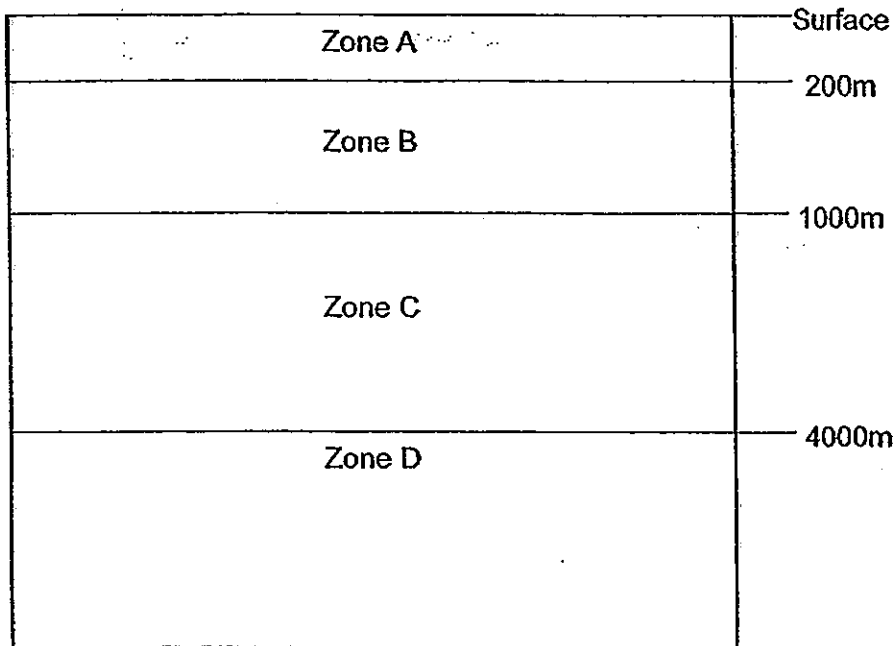

Zones	Description
A	<ul style="list-style-type: none"> • Top layer of the ocean zone • Supports 90% of ocean life
B	<ul style="list-style-type: none"> • Very little sunlight can pass through • Some animals that live here are able to move between this zone and Zone A
C	<ul style="list-style-type: none"> • No sunlight reaches this zone • Very few animals live here
D	<ul style="list-style-type: none"> • No sunlight reaches this zone • Very few animals live here

a) Explain why plants are not found in Zone B. (1m)

b) If the animals in Zone B are able to survive with little oxygen, what is the purpose of them moving up to Zone A? (1m)

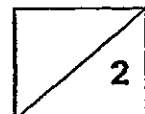

37. Animal X feeds on other mammals, birds, eggs, lizards and tree frogs. It is able to imitate the distress call of the young of Animal Y. The adult of Animal Y takes care of its young.



Animal X



Animal Y

- a) How is the ability of imitating the distress call of the young of Animal Y an advantage to Animal X? (1m)

- b) The non-poisonous king snake looks like the poisonous coral snake.



Coral snake

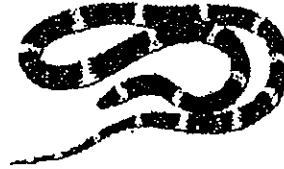

King snake

- i) State whether looking like the coral snake is a structural or behavioral adaptation of the king snake. (1m)

- ii) How does looking like the coral snake an advantage to the king snake? (1m)

- c) The picture below shows a fish with an eyespot.

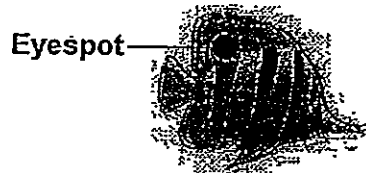

- How does having an eyespot reduce the chances of the fish being eaten? (1m)

38. Jane placed 2 iron nails at each end of the magnet as shown in the diagram below.

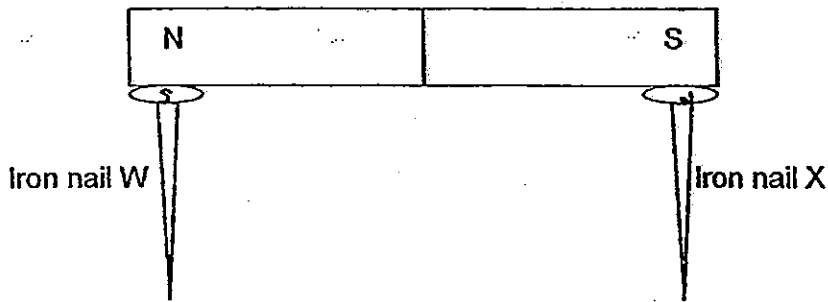

She noticed that both the iron nails were able to attract a few paper clips after she removed them from the magnet.

- a) What will happen to the iron nails when she then placed them near each other as shown in the diagram below? Give a reason for your answer. (1m)

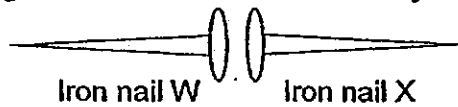

Jane then placed another 2 iron nails at the same end of the magnet as shown in the diagram below.

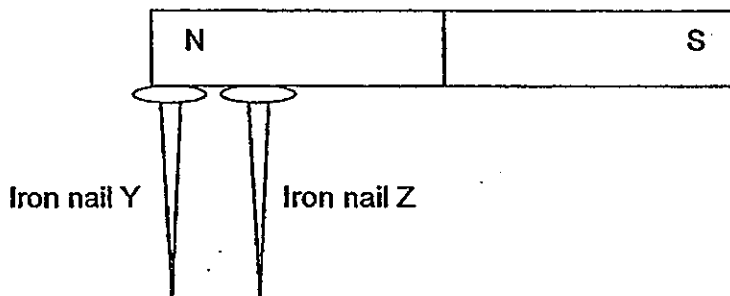

- b) What will happen to the iron nails when she then placed them near each other as shown in the diagram below? (1m)

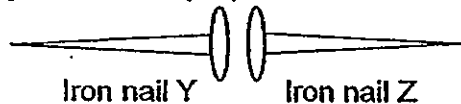

- c) After the experiment, Jane does not want the iron nails to have the ability to attract the paper clips. State 2 different ways where Jane can make the iron nails lose their ability to attract paper clips. (1m)

39. John dragged a wooden block across a table with 4 different surfaces and the results of the experiment are shown in the table below.

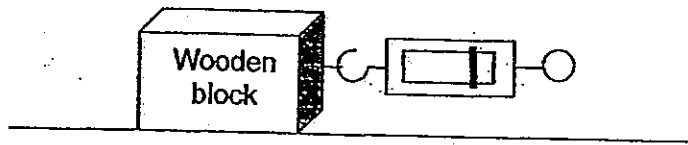

Table

Type of Surface	Average force needed (N)
A	105
B	88
C	127
D	94

- a) Arrange in order, starting from the smoothest surface to the roughest surface. (1m)

In another experiment, John glued Surface A from the first experiment onto a ramp and pulled the same wooden block up the ramp.

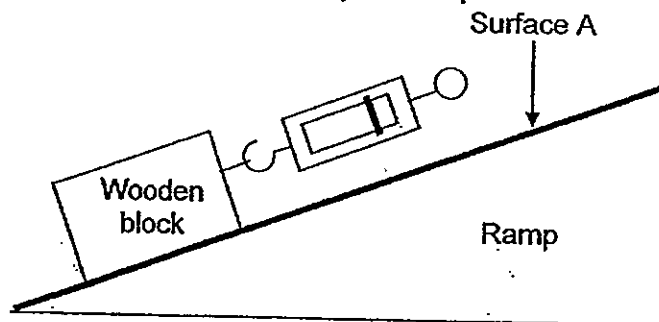

- b) Will the force needed to pull the wooden block up the ramp be more than, less than or the same as 105N? Explain your answer. (1m)

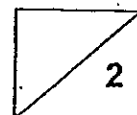

40. Lily wanted to find out which is the most suitable paint to be painted onto the lower part of the tree trunks along dimly-lit roads. She set up an experiment as shown below.

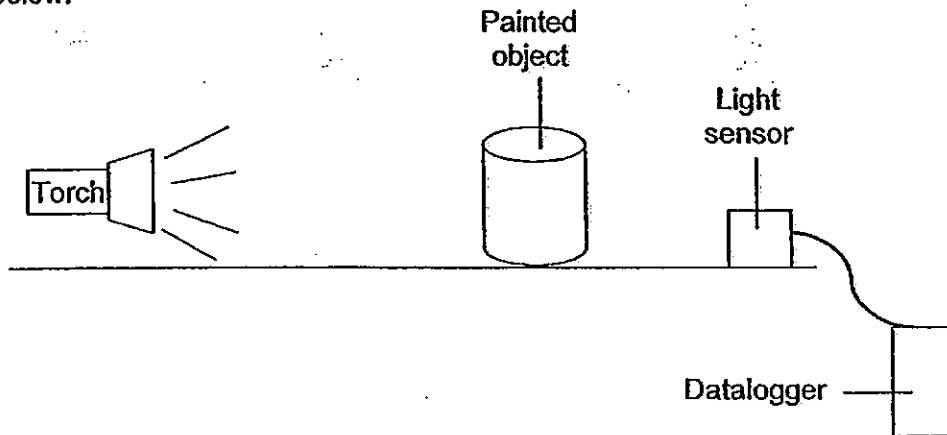

- a) Explain why the light sensor should not be placed behind the painted object in Lily's experiment. (1m)

After Lily has corrected her experiment, she collected the results and plotted the graph as shown below.

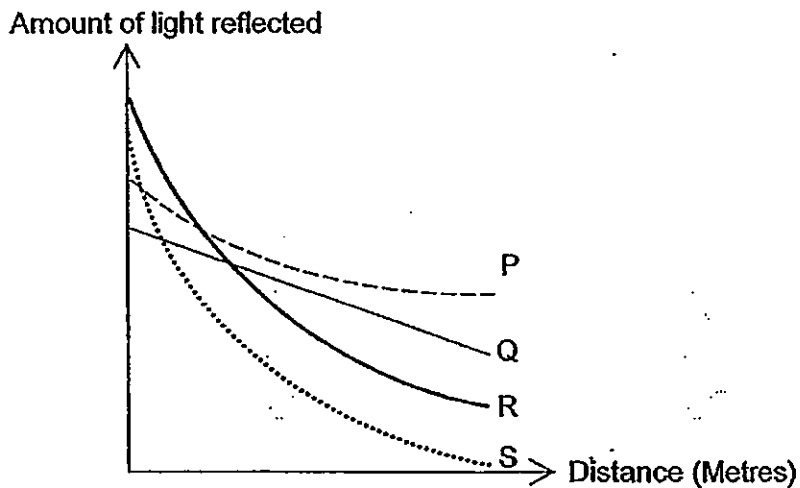

- b) Based on Lily's graph, which is the most suitable paint to be painted onto the lower trunks of the trees on roads that are dimly lit? (1m)

41. Jimmy poured 500ml of water at 90°C into a large container and another 500ml of water at 90°C into 5 separate containers as shown in the diagrams below.

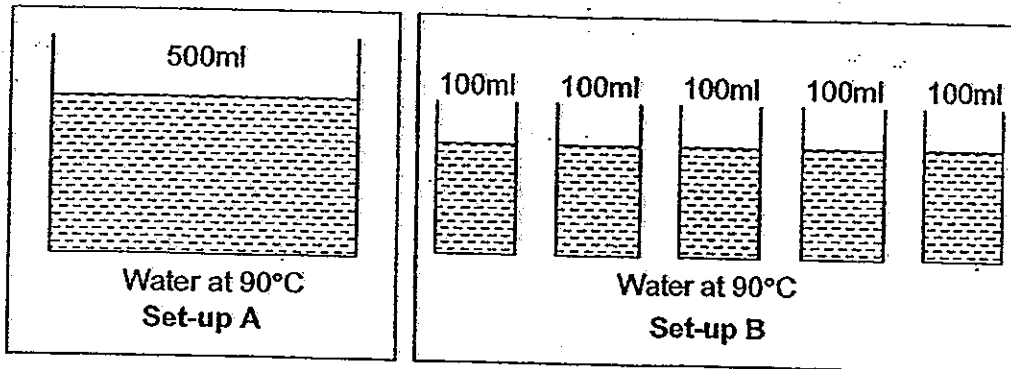

- a) Jimmy placed all the containers at the same location. What variable was kept the same by placing all the containers at the same location? (1m)
-
- b) Explain why the water in Set-up B has a lower temperature than the water in Set-up A after a few minutes. (1m)
-

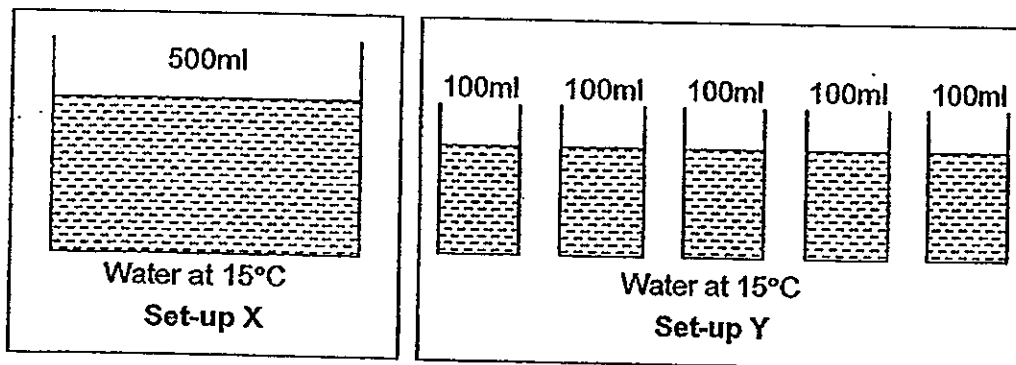

- c) Jimmy conducted a similar experiment but this time, he used water at 15°C. In which set-up would the water reach the room temperature first? (1m)
-

42. Study the flowchart carefully.

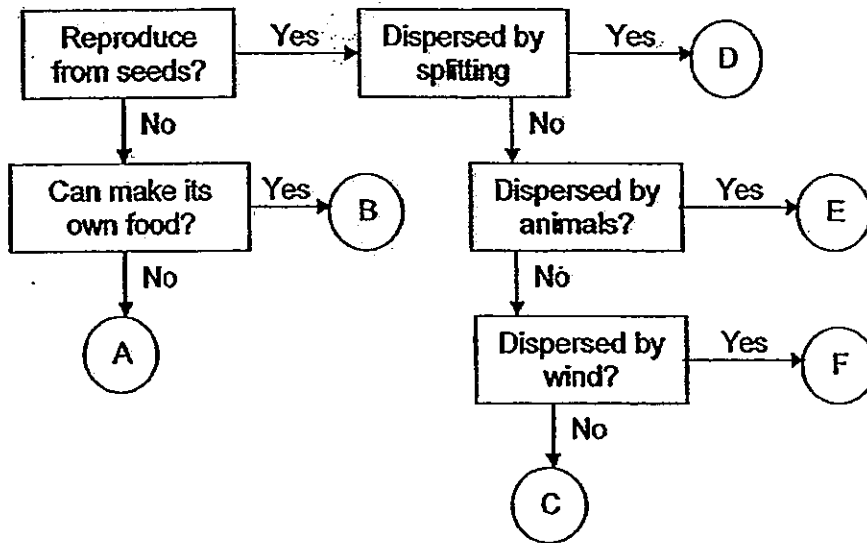

a) Based on the flow chart, what is the difference between B and D? (1m)

b) Based on the flow chart, describe the characteristics of E. (1m)

c) In which group does the coconut belong to? (1m)

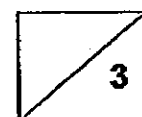

43. Liquid X evaporates much faster than water. When the same amount of water and Liquid X at room temperature are poured into 2 containers of the same size, it was observed that water droplets were formed on the outer surface of Container B. However, water droplets were not formed on the outer surface of Container A.

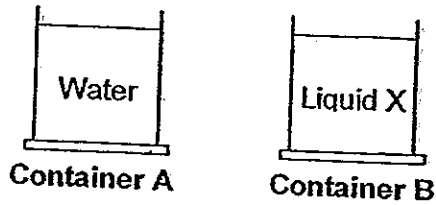

- a) Explain why water droplets were formed on the outer surface of container B. (2m)

Equal amounts of water and Liquid X were mixed together and poured into Container C.

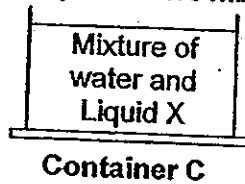

The table below shows the percentage of water and Liquid X in the mixture left in the container as it evaporates.

Time	Percentage of water in Mixture	Percentage of Liquid X in Mixture
0 hour	50%	50%
2 hour	65%	35%
4 hour	80%	20%
6 hour	95%	5%
8 hour	100%	0%

- b) The graph below shows the rate of evaporation of water over 8 hours in Container D which has the same size as Container C. Draw another line in the graph to show the rate of evaporation of the mixture in Container C over 8 hours. (1m)

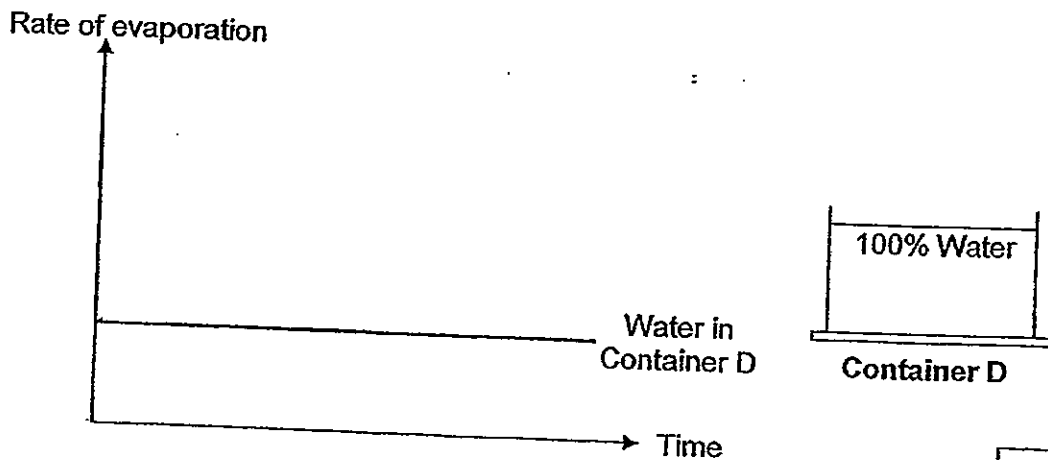

44. Mrs Lee wrapped the leaves of a plant with a plastic bag.

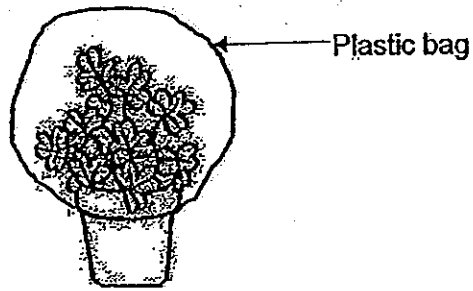

- a) What will she observe in the plastic bag after a few days? (1m)

Mrs Lee then carried out an experiment as shown in the diagram below.

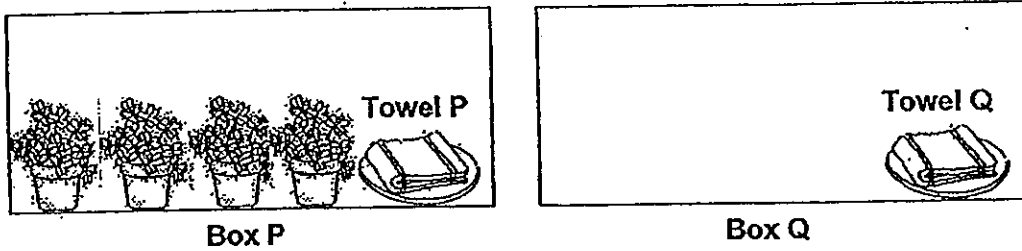

- b) She placed 2 towels that are equally wet in 2 boxes of the same size. Box P has many plants while Box Q does not have any plant. She noticed that Towel P dried more slowly than Towel Q. Explain why this happened. (2m)

SCGS Primary P6 SA1 Answers

Booklet A

1) 2	6) 2	11) 3	16) 2	21) 4	26) 3
2) 1	7) 4	12) 3	17) 1	22) 1	27) 3
3) 2	8) 3	13) 1	18) 2	23) 2	28) 2
4) 4	9) 4	14) 4	19) 4	24) 3	29) 2
5) 2	10) 4	15) 1	20) 3	25) 2	30) 2

Booklet B

Qn	Suggested Answer (does not include all possible answers)			
31a.	No. The pan has weight/mass (20g) so the total mass needed to break Material P without Substance X is 161 g / more than 141g			
31b.	The width of Material P will affect the results of the experiment.			
31c.	Adding Substance X causes Material P to become <u>weaker</u> .			
32a.	She could observe the amount of water left in the beaker after a fixed period of time.			
32b.	Yes. The plant has taken in water in the first experiment and this will affect the amount of water the plant takes in in the second experiment.			
33.		True	False	
	a)	✓		
	b)	✓		
	c)		✓	
	d)		✓	
34a.	P, Q, S			
34b.	None			
35a.	5			
35b.	3			
35c.	D			
35d.	Yes. It has B and F to feed on./ It still has food sources, B and F.			
36a.	There is not enough light for the plants to make food / carry out photosynthesis.			
36b.	To look for food.			
37a.	The calls of Animal X will attract the adult Animal Y to it and Animal X can prey / eat on the adult Animal Y.			
37bi.	Structural			
37bii.	The predators of the king snake may mistake it for the poisonous coral snake and avoid eating it.			
37c.	The predators of the butterfly fish may mistake it for a larger animal and avoid it.			

38a.	They will <u>attract</u> as they are <u>unlike poles</u> are facing each other.
38b.	They will <u>repel</u> as the <u>like poles</u> are facing each other.
38c.	Hit the iron nails several times Drop the iron nails several times. Heat the iron nails
39a.	B, D, A, C
39b.	More than. The wooden block is being moved in the <u>opposite</u> direction as the pull of gravity/ has to <u>overcome</u> the force of gravity.
40a.	The object will block the light sensor. / The object will cast a shadow on the light sensor.
40b.	P
41a.	The temperature of the surrounding
41b.	The water in Set-Up B has more surface area exposed to the surrounding so it could lose heat faster.
41c.	Y
42a.	D reproduce from seeds but B does not.
42b.	E reproduce from seeds and is dispersed by animals.
42c.	C
43a.	As Liquid X evaporates, Container B loses heat and becomes cooler so the water vapour in the surrounding condensed onto the outer surface to form water droplets.
43b.	<p style="text-align: center;">Rate of evaporation</p> <p style="text-align: center;">Time</p>
44a.	Water droplets
44b.	There were plants in Box P which gave out water vapour. This increases the humidity of the air in the room and slows down the rate of evaporation of Towel P. / There was more water vapour in the air in the Box P so the rate of evaporation of Towel P is slower.