



MAHA BODHI SCHOOL
2018 SEMESTRAL ASSESSMENT 2
PRIMARY FIVE SCIENCE
(BOOKLET A)

Name : _____ ()

Class : Primary 5 _____

Date : 26 October 2018

Total Duration for Booklets A and B : 1 h 45 min

INSTRUCTIONS TO CANDIDATES:

1. Do not turn over this page until you are told to do so.
2. Follow all instructions carefully.
3. Answer all questions.
4. Shade your answers in the Optical Answer Sheet (OAS) provided.

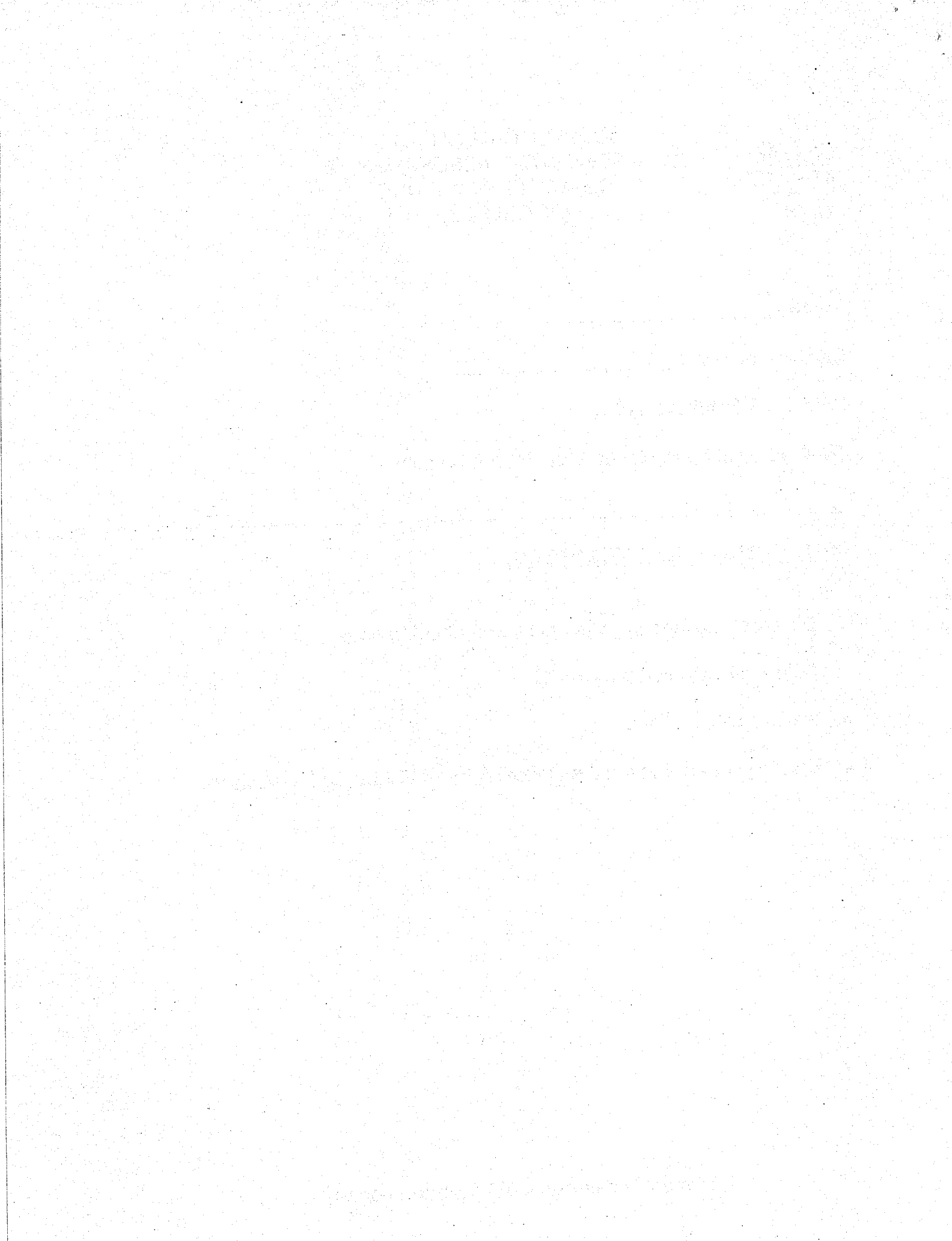

BOOKLET A : [28 x 2 marks = 56 marks]

For each question from 1 to 28, four options are given. One of them is the correct answer. Make your choice (1, 2, 3 or 4). Shade your answer on the Optical Answer Sheet.

1. The diagram below shows the water cycle.

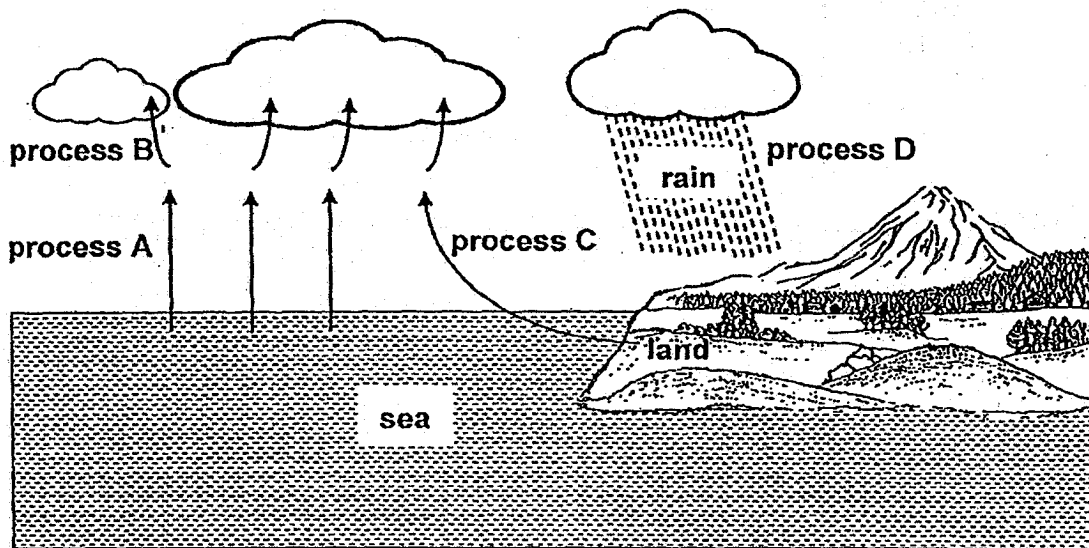

Which of the processes above involve(s) heat loss from water?

- (1) A only
- (2) B only
- (3) B and C only
- (4) C and D only

2. Substance X has a freezing point of 23°C and a boiling point of 85°C . The graph below shows how the temperature of the substance changes over time in an experiment.

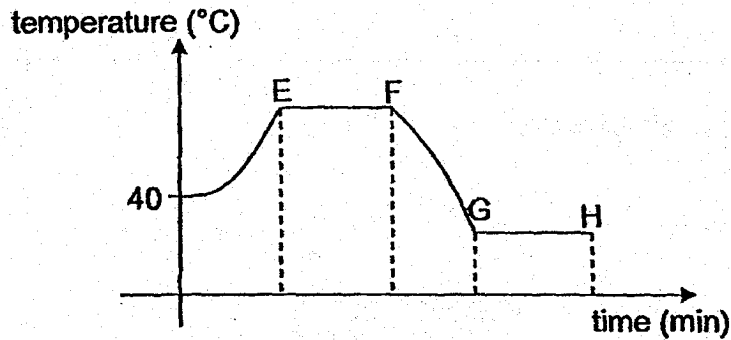

Which of the following shows the correct state(s) of substance X during the time period EF?

- (1) solid only
 - (2) liquid only
 - (3) solid and liquid only
 - (4) liquid and gas only
3. The diagram below shows a cell and some of its parts.

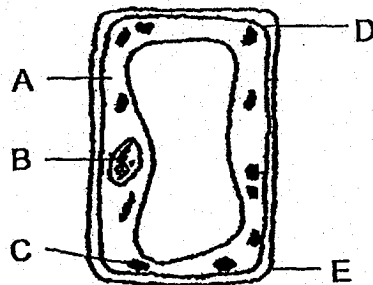

Which of the following headings best matches the cell parts A to E?

	supports the cell	controls activities in the cell	found in animal cells
(1)	E	C	A, B, C
(2)	D	A	A, B, E
(3)	A	C	C, D, E
(4)	E	B	A, B, D

4. The diagram below shows the male and female reproductive systems.

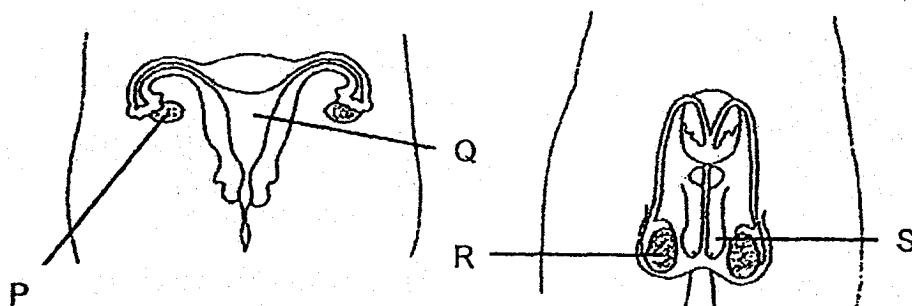

Which parts stated above produce the reproductive cells?

- (1) P and R
- (2) P and S
- (3) Q and R
- (4) Q and S

5. The diagram below shows two cats.

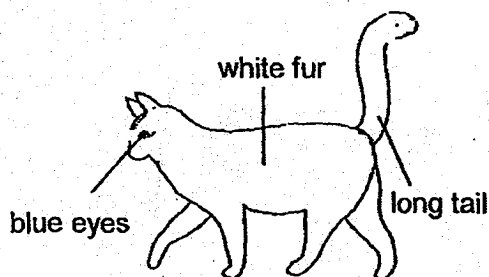
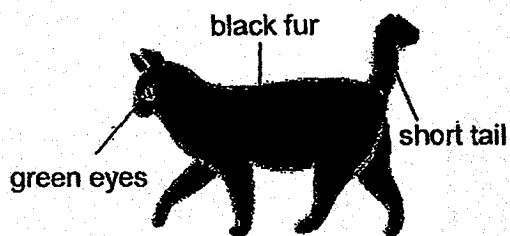

Which one of the following kittens shown below would most likely be the young of the two cats?

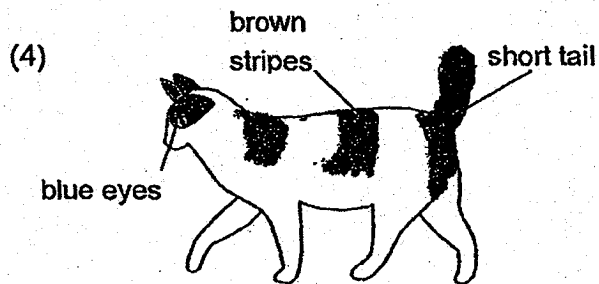
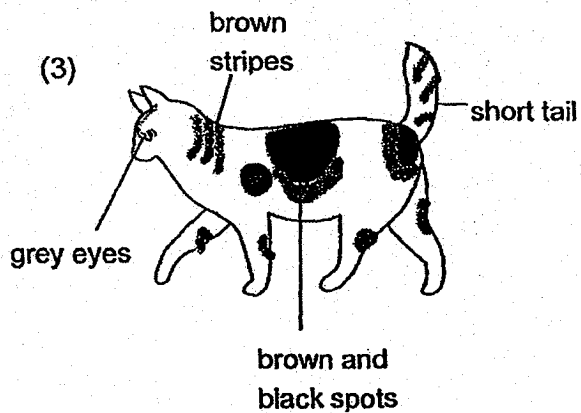
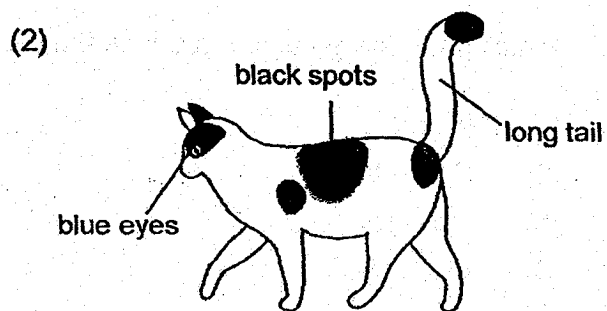
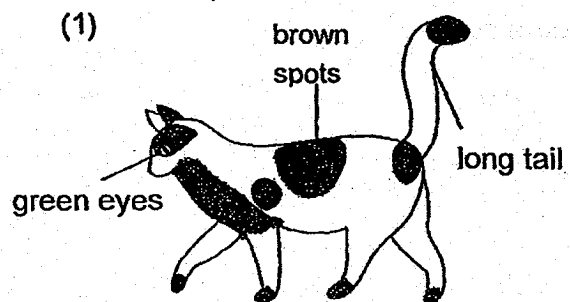

6. The diagram below shows a fruit from plant P.



Jamie wanted to find out if the fruit could be dispersed by water.

Which of the following actions could be used to help her in her investigation?

- A. Measure the mass of the fruit.
 - B. Place the fruit in water to observe if it floats.
 - C. Open the fruit to see if it contains a fibrous husk.
-
- (1) A and B only
 - (2) B and C only
 - (3) A and C only
 - (4) A, B and C

7. Jenny wanted to find out if living things give out carbon dioxide. She set up an experiment, as shown in the diagram below, to measure the amount of carbon dioxide in the air.

At the start of the experiment:

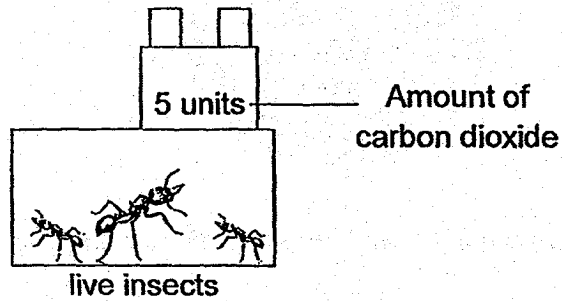

At the end of the experiment after three hours:

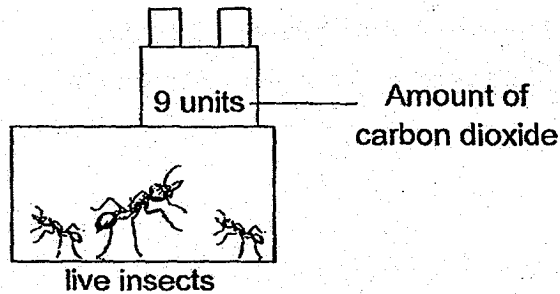

Based on the data collected, what could Jenny conclude from the experiment?

- A. Living things take in oxygen.
 - B. Living things give out carbon dioxide.
 - C. As the number of insects increases, the amount of carbon dioxide given out increases.
- (1) B only
 - (2) C only
 - (3) A and C only
 - (4) A, B and C

8. The graph shows Ahmad's heart rate over a period of one hour.

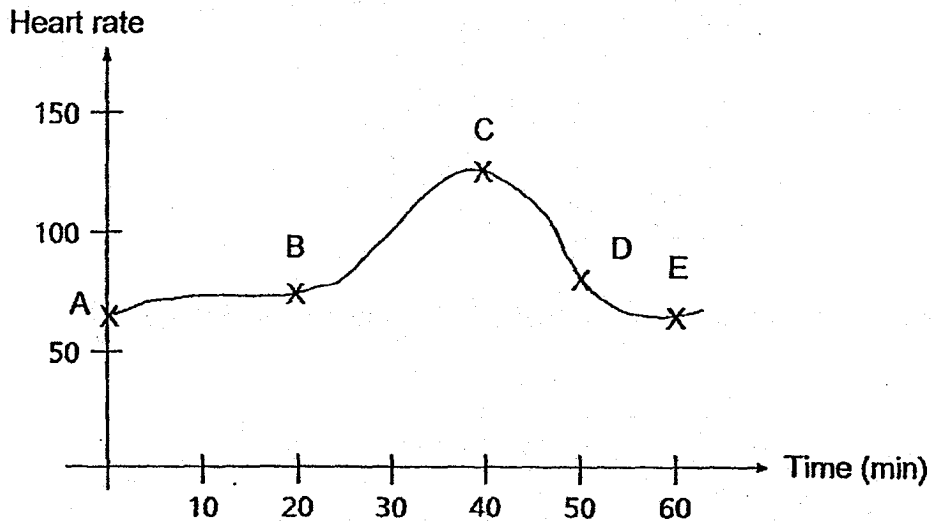

Which part of the graph shows that he was exercising?

- (1) AB
 - (2) BC
 - (3) CD
 - (4) DE
9. The diagram shows the amount of different gases, W, X and Y, in the air.

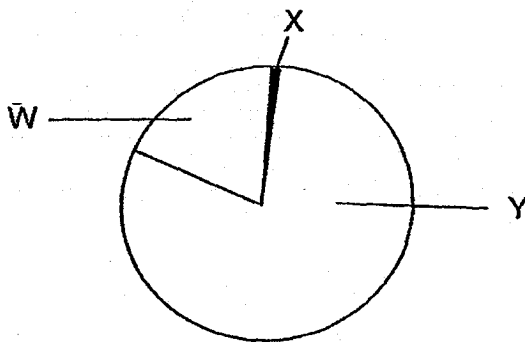

Which of the following statements is/are true?

- A. Plants take in W all the time through the leaves.
 - B. Animals breathe out only X to their surroundings.
 - C. Animals take in W, X and Y during gaseous exchange.
- (1) A only
 - (2) A and B only
 - (3) B and C only
 - (4) A, B and C

10. Kimi set up a simple electric circuit as shown in the diagram below.

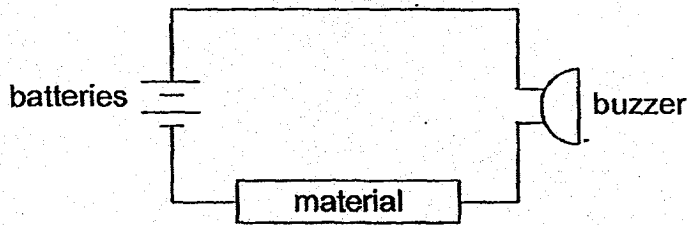

She changed the material in the circuit and recorded her observations in the table below.

Material	Did the buzzer ring?
H	Yes
I	No
J	Yes
K	No

Which of the following options in the table below shows the correct classification of the materials?

	Conductor of electricity	Insulator of electricity
(1)	H	I, J and K
(2)	H and J	I and K
(3)	I and J	H and K
(4)	I and K	H and J

11. The diagram below shows a circuit.

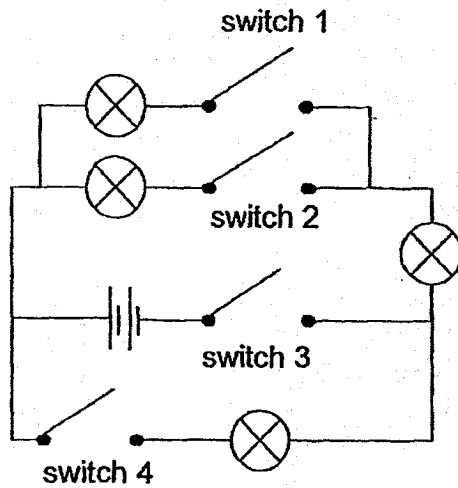

Which of the following shows the correct number of light bulbs lighted up when the different switches were closed?

	Switches closed	Number of light bulbs lit
(1)	1 and 2	2
(2)	1 and 3	3
(3)	2 and 4	3
(4)	3 and 4	1

12. Study the chart below.

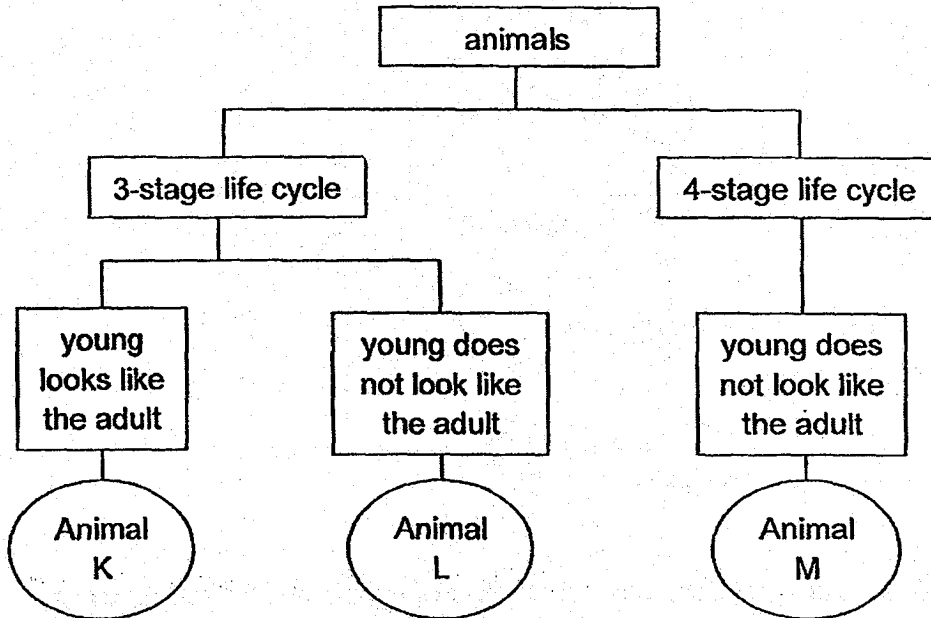

Which of the following shows correctly the animals K, L and M?

	Animal K	Animal L	Animal M
(1)	grasshopper	chicken	cockroach
(2)	beetle	chicken	grasshopper
(3)	frog	grasshopper	butterfly
(4)	grasshopper	frog	beetle

13. Two bar magnets and object Q are placed near one another in two different arrangements, as shown below.

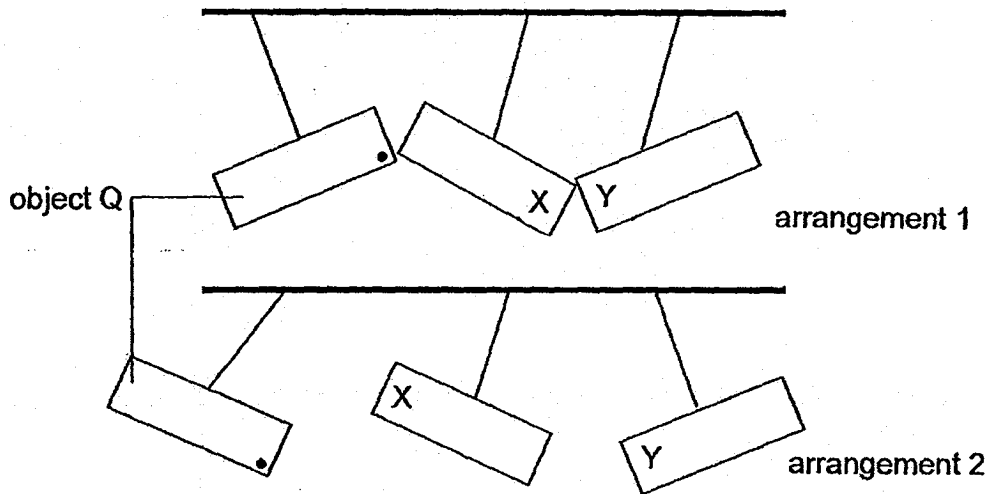

Which of the following correctly describes object Q and the poles, X and Y, of the two bar magnets?

	Pole X	Pole Y	Object Q
(1)	north	north	magnet
(2)	north	south	magnet
(3)	south	south	magnetic object
(4)	south	north	non-magnetic object

14. The diagram below shows a Ferris wheel.

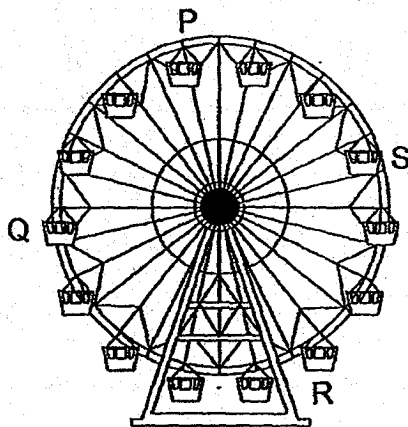

Which point, P, Q, R or S, on the Ferris wheel has the lowest gravitational potential energy?

- (1) P
 - (2) Q
 - (3) R
 - (4) S
15. Emily released the air in a swimming float. She heard a hissing sound as the air was released and she felt the escaping air on her hand.

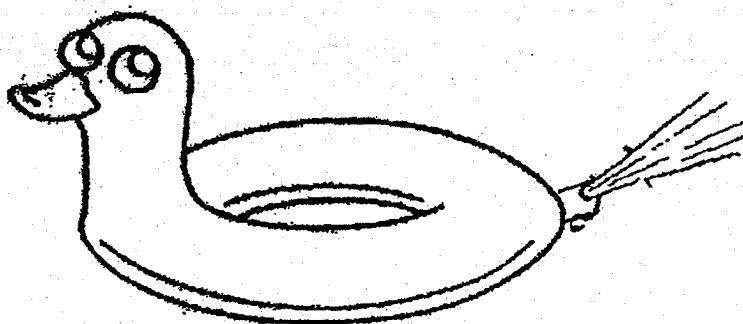

Which of the following describes the energy change?

- (1) potential energy \rightarrow heat energy
- (2) kinetic energy \rightarrow potential energy
- (3) potential energy \rightarrow kinetic energy + sound energy
- (4) kinetic energy \rightarrow sound energy + potential energy

16. Keith prepared two set-ups as shown in the diagram below.

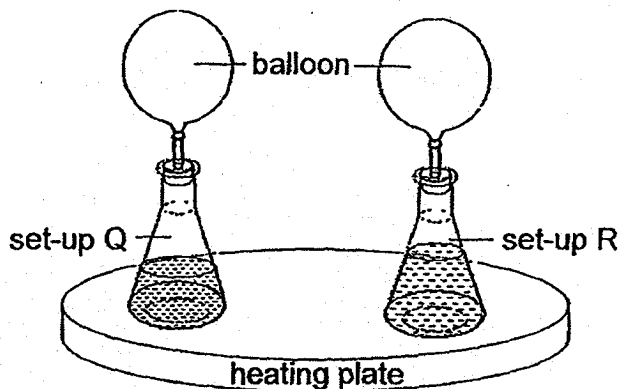

Two minutes after the heating plate was switched on, the balloons attached to the flasks inflated. Keith noticed the balloon in set-up Q was larger than the balloon in set-up R.

Which of the following statements could explain Keith's observation?

- A. The water in set-up Q was warmer.
- B. The water in set-up Q had a larger exposed surface area.
- C. The water in set-up Q received more heat than set-up R.

- (1) A only
- (2) B only
- (3) A and B only
- (4) B and C only

17. Daniel wanted to find out how different conditions in the environment would affect the rate of evaporation of water.

He placed three similar beakers containing 500 ml of water in different locations as shown in the diagram below.

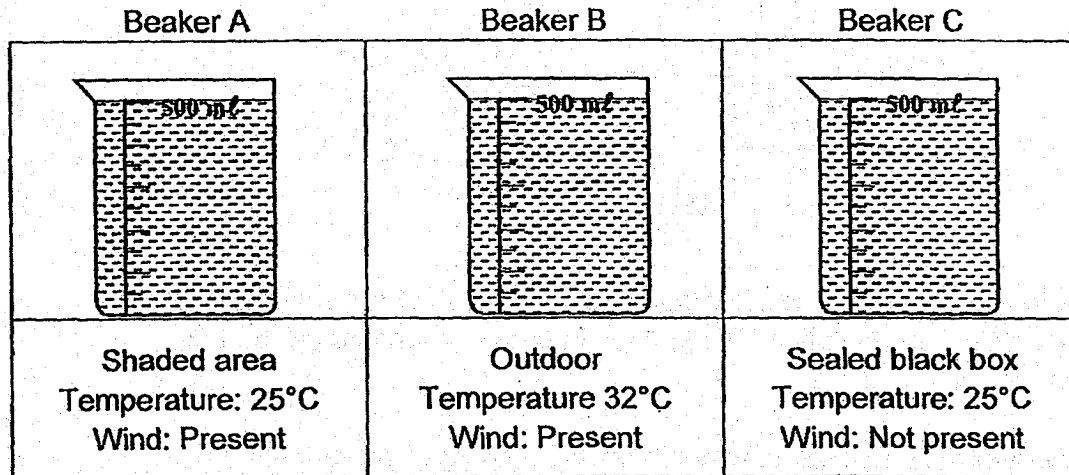

At the end of the experiment, he measured the volume of water left in the beakers and recorded them in a table.

Which of the following shows the correct order of the beakers based on the amount of water left?

	Highest volume of water left	→	Lowest volume of water left
(1)	A	B	C
(2)	B	A	C
(3)	C	A	B
(4)	C	B	A

18. The diagram below shows the flow of substances W, Y and Z.

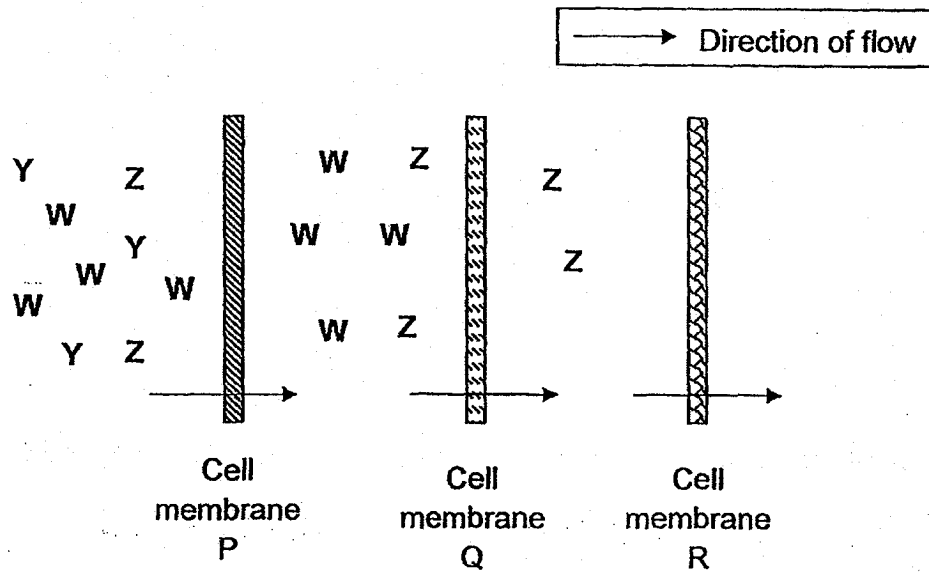

Which of the following statements are most likely to be true?

- A. Q allows Z to pass through.
- B. P does not allow Y to pass through.
- C. P and Q allow W and Z to pass through.
- D. R does not allow W and Z to pass through.

- (1) A and B only
- (2) C and D only
- (3) A, B and C only
- (4) A, C and D only

19. Jane was collecting seeds for her project. She found six seeds in the apple that she ate.

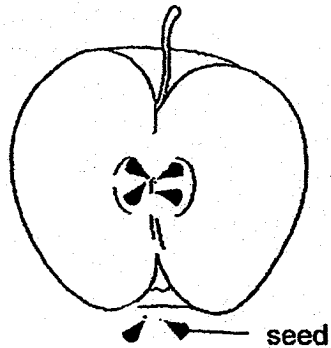

In how many ovules were the eggs fertilized in order to form the apple that she ate?

- (1) three
- (2) six
- (3) eight
- (4) twelve

20. A circuit card was made with four steel paper clips, P, Q, R and S, attached to it. Some of the paper clips were connected to one another with wires.

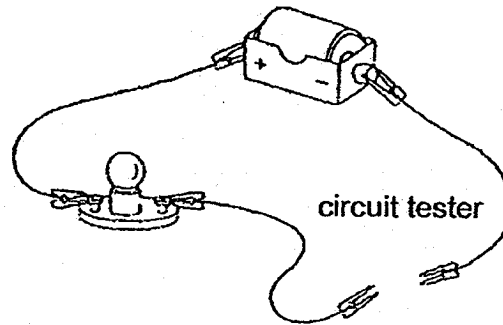
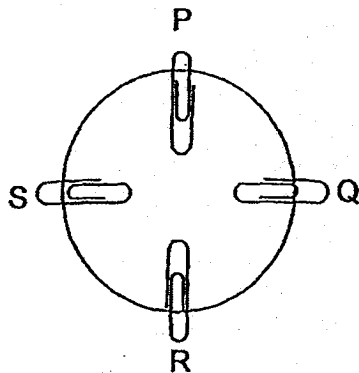

A circuit tester was used to find out how the paper clips were connected. The results of the tests are shown below:

Clips connected	Did the bulb light up?
P and Q	No
P and R	Yes
Q and R	No
Q and S	No
R and S	Yes

Which of the following shows the correct connection between the clips?

(1)

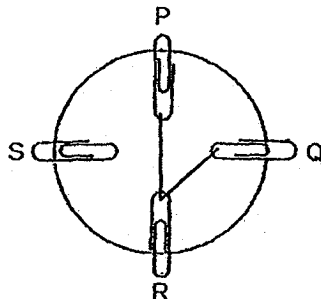

(2)

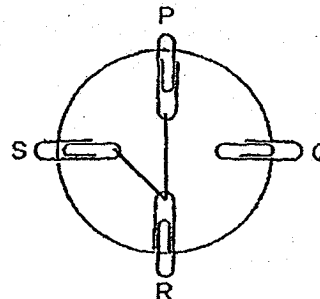

(3)

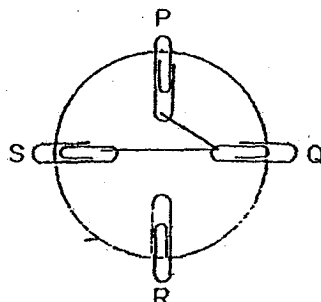

(4)

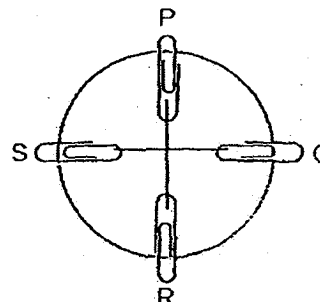

21. Observe the electric circuits shown below.

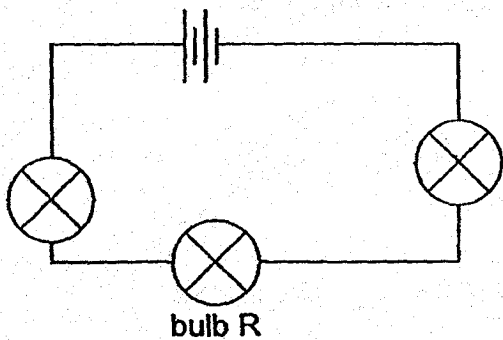

Circuit L

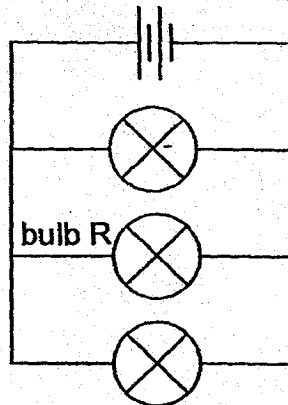

Circuit M

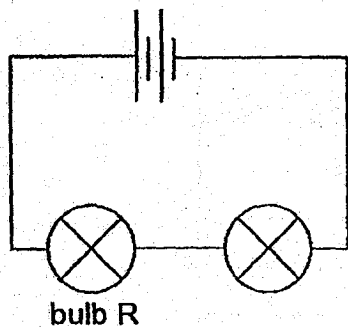

Circuit N

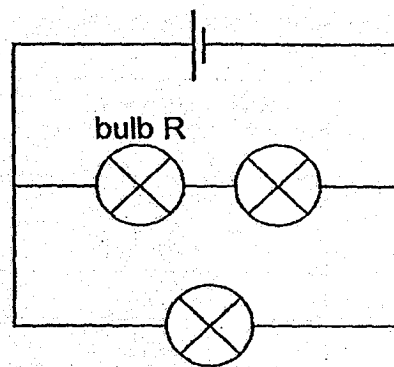

Circuit O

Which of the following shows the arrangement of the circuits based on the ascending order of the brightness of bulb R?

- (1) O, L, N, M
- (2) L, M, N, O
- (3) M, N, L, O
- (4) N, O, M, L

22. The diagram below shows the position of a styrofoam ball inside an inverted plastic cup.

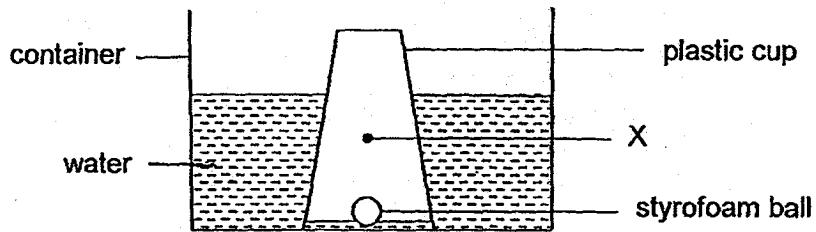

If a hole is pricked at position X of the plastic cup, which one of the following diagrams shows the correct position of the styrofoam ball?

(1)

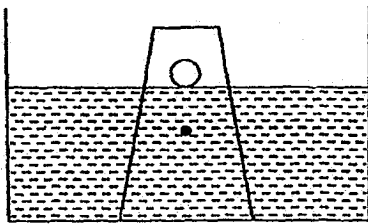

(2)

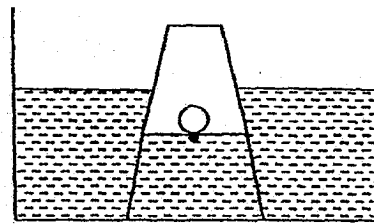

(3)

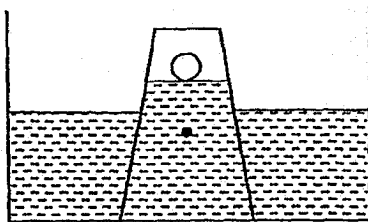

(4)

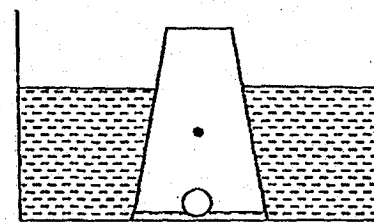

23. In a shadow puppet show, the puppet handler often shifts the position of the puppets to change the size of the shadow formed on the screen. The puppets are all of the same size.

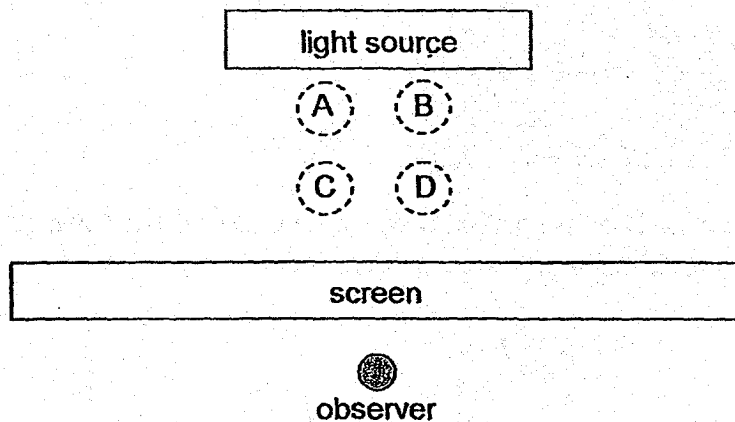

The observer sees the shadows, as shown below, during the show.

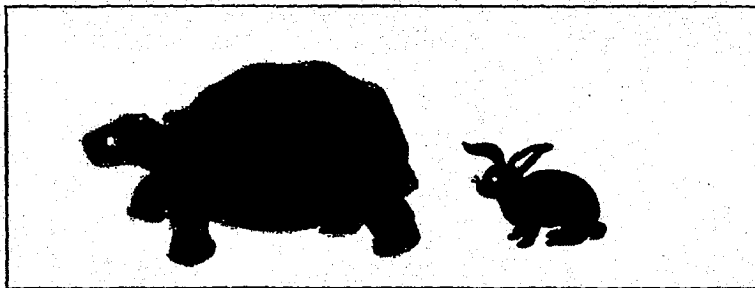

Which of the following are the correct positions of the puppets on the stage which would form the shadows as seen by the observer?

- (1) A and B
- (2) A and D
- (3) B and C
- (4) C and D

24. Shufen could not loosen the metal lid of a jam jar and so she placed the lid in a basin of hot water and soon she was able to turn the lid easily.

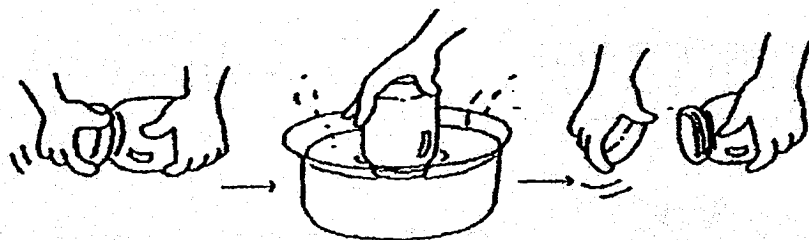

Why was Shufen able to turn the lid easily?

- (1) The lid gained heat from the hand and contracted.
 - (2) The lid gained heat from the hot water and expanded.
 - (3) The lid gained heat from the hot water and the jar contracted.
 - (4) The jar gained heat from the hot water and expanded and the lid contracted.
25. Identical burners were used to heat three beakers with different amounts of tap water in the same room as shown in the diagram below. The water in each beaker was heated until it just started to boil and the time taken was recorded.

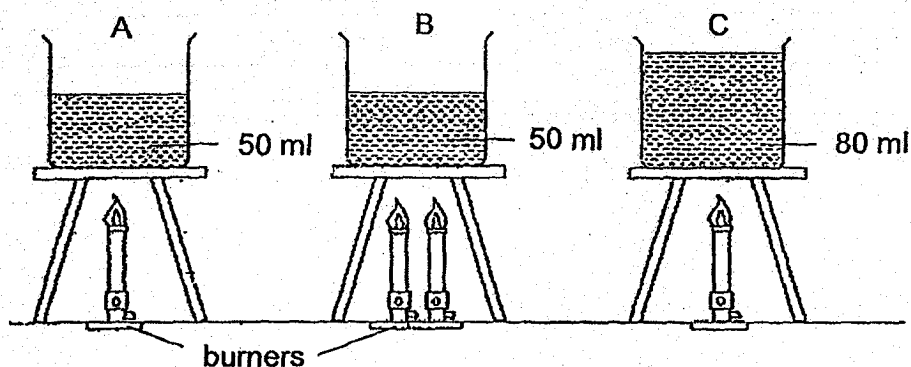

Which one of the following is a correct statement on the set-ups at the time when the water just started to boil?

- (1) Set-up B had the highest temperature.
- (2) Set-up A had less heat than Set-up B.
- (3) Set-up C had more heat than Set-up A and Set-up B.
- (4) Set-up A took the longest time to reach the boiling point of water.

26. Bobby set up an experiment as shown in the diagram below.

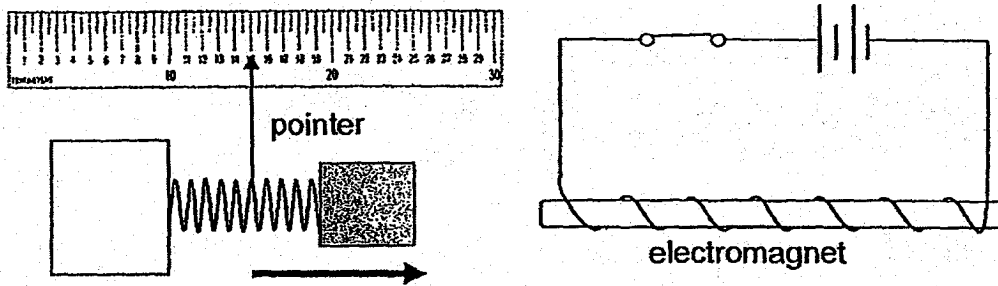

The pointer attached to the spring moved when the circuit was closed.

The number of coils of wire around the electromagnet was then increased.

Which of the following correctly shows how the pointer would move and the change in the strength of the electromagnet?

	How the pointer moved	Strength of the electromagnet
(1)	left	decreased
(2)	left	increased
(3)	right	decreased
(4)	right	increased

27. Ailing wanted to find out which material, R, S, T and U, would be most suitable to make a pair of gloves that would keep her hands dry.

She dipped material R into a container of 200 ml of tap water as shown in the diagram below.

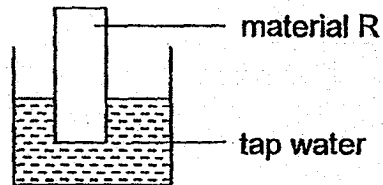

The amount of water left in the container after R was removed was recorded.

She repeated the experiment with materials S, T and U and recorded the results in the table below.

Material	Amount of water left (ml)
R	155
S	200
T	135
U	175

Based on the information, which material should Ailing choose to make the gloves?

- (1) R
- (2) S
- (3) T
- (4) U

28. Study the flowchart below.

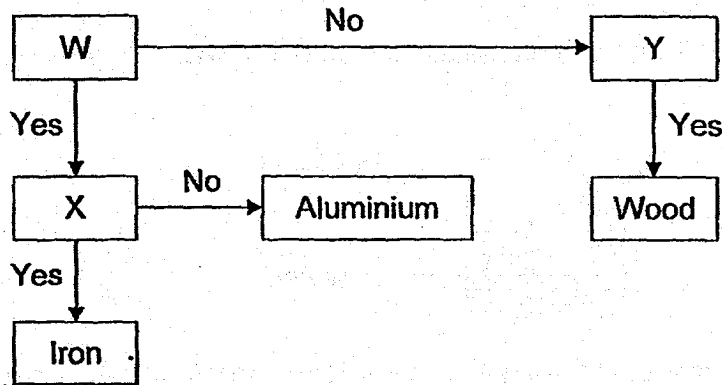

Which of the following are the questions that should be placed in boxes W, X and Y to identify the three materials shown?

	W	X	Y
(1)	Can it float on water?	Is it a good conductor of heat?	Is it magnetic?
(2)	Is it magnetic?	Is it a good conductor of heat?	Can it float on water?
(3)	Is it magnetic?	Can it float on water?	Is it a good conductor of heat?
(4)	Is it a good conductor of heat?	Is it magnetic?	Can it float on water?

END OF BOOKLET A

GO ON TO BOOKLET B



MAHA BODHI SCHOOL
2018 SEMESTRAL ASSESSMENT 2
PRIMARY FIVE SCIENCE
(BOOKLET B)

Name : _____ ()

Class : Primary 5 _____

Date : 26 October 2018

Total Duration for Booklets A and B : 1 h 45 min

INSTRUCTIONS TO CANDIDATES:

1. Do not turn over this page until you are told to do so.
2. Follow all instructions carefully.
3. Answer all questions.
4. Write all your answers in this booklet.

Booklet	Marks Obtained	Maximum Marks
A		56
B		44
Total		100
Practical Test		10

Parent's Signature : _____

This booklet consists of 22 printed pages.

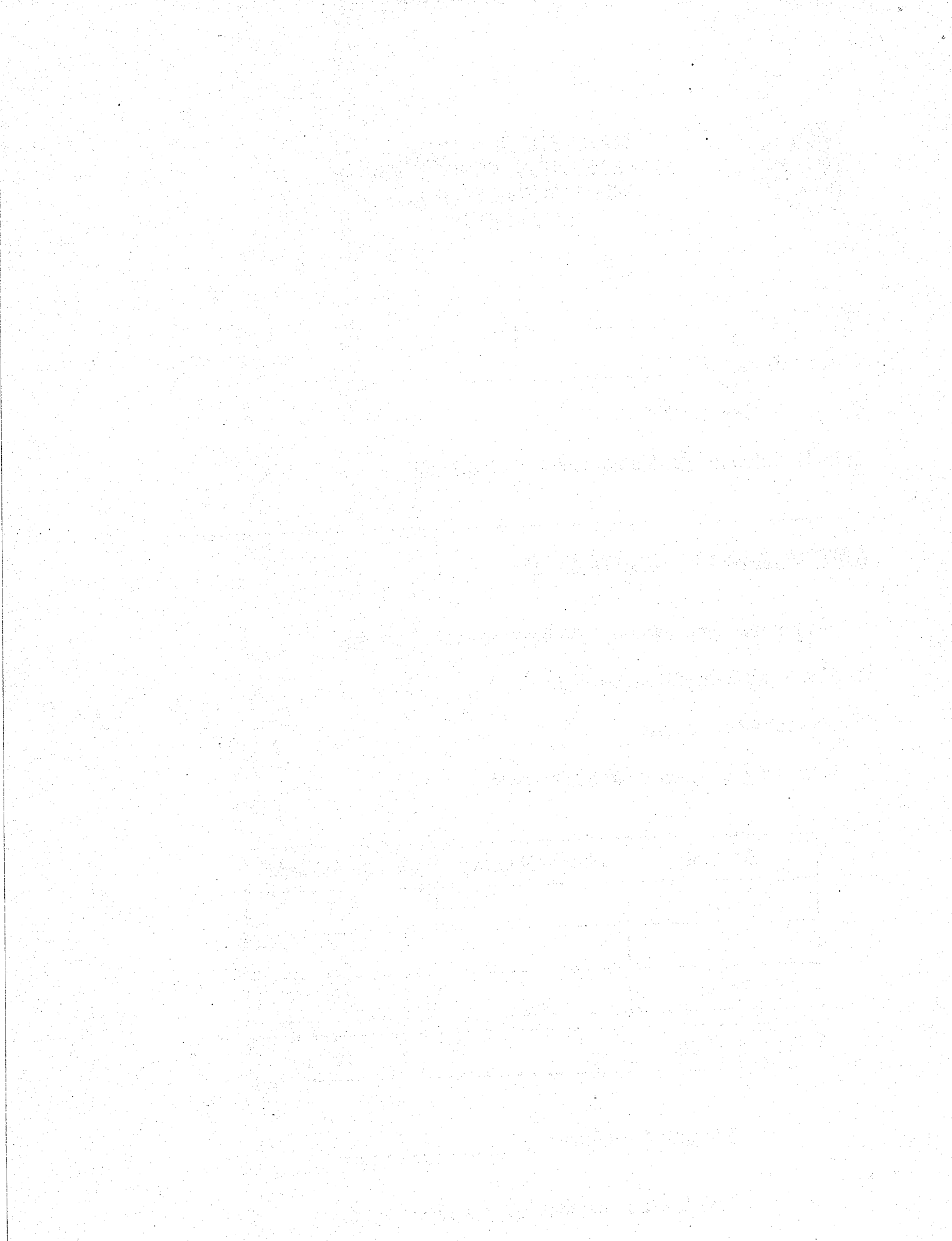

BOOKLET B : [44 marks]

For questions 29 to 41, write your answers in this booklet.

The number of marks available is shown in the brackets [] at the end of each question or part-question.

29. (a) A student has a toy as shown in the diagram below. In the toy, there are two balls, A and B, which are suspended with strings.

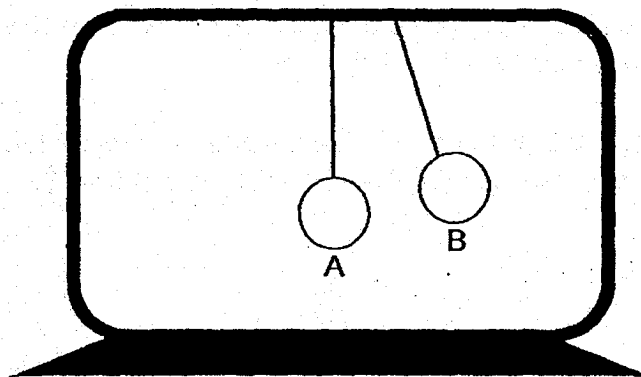

He observes that when he releases ball B from a certain height, it hits ball A which then swings.

- (i) State the energy change occurring in ball B after it is released. [1]

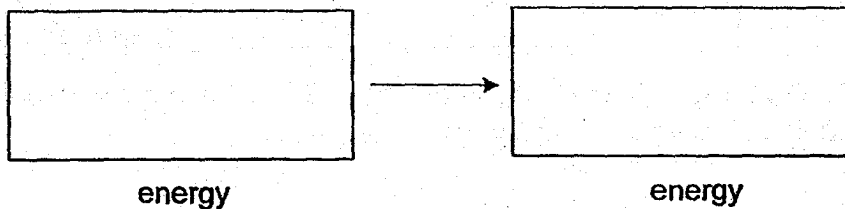

- (ii) The student observes that both balls stop moving after some time. Explain why the balls stop moving. [1]

Marks :

12

- (b) Mrs Lee ordered a cup of hot tea and it was served in a paper cup with a sleeve. She held the cup at two positions, C and D, and found that there was a difference.

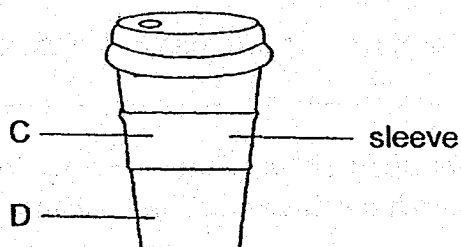

At position D, she felt the heat from the hot tea but at position C, where the sleeve was, she did not feel as much heat.

The graph below shows the increase in temperature of two materials, S and Q, when they were heated with the same amount of heat till they reached 100°C .

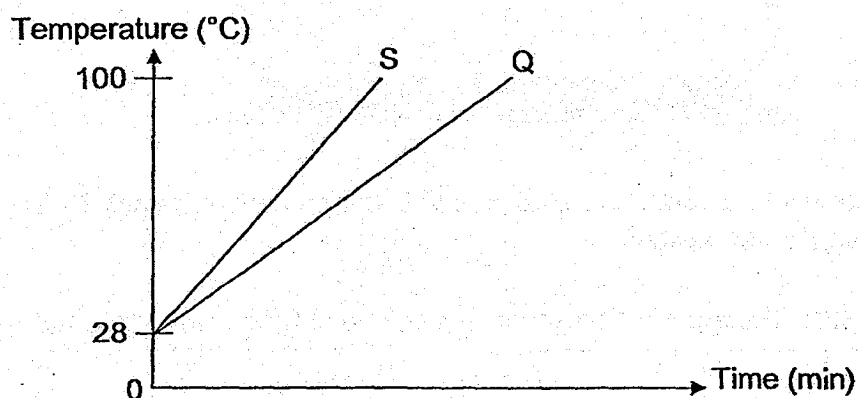

- (i) Using the graph, state which material (S or Q) is more suitable for making the sleeve. Explain your answer. [2]

- (ii) After holding the cup of hot tea with her right hand, Mrs Lee then placed both hands into a basin of water at room temperature. Which of her hands would feel warmer? [1]

Marks : / 3

30. (a) The diagram below shows the main parts of a power station.

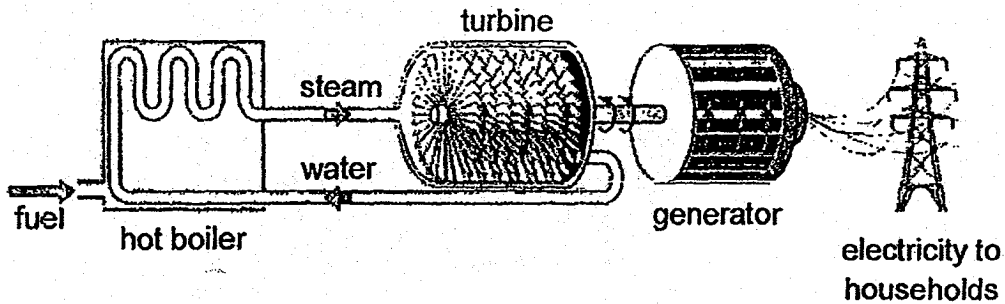

There are three main stages in the production of electricity:

Stage 1 - fuel is burned to boil water to make steam

Stage 2 - steam makes a turbine spin

Stage 3 - spinning turbine turns a generator which produces electricity

Based on these stages, show the energy changes that take place in the power station by filling in each box with the correct form of energy. [2]

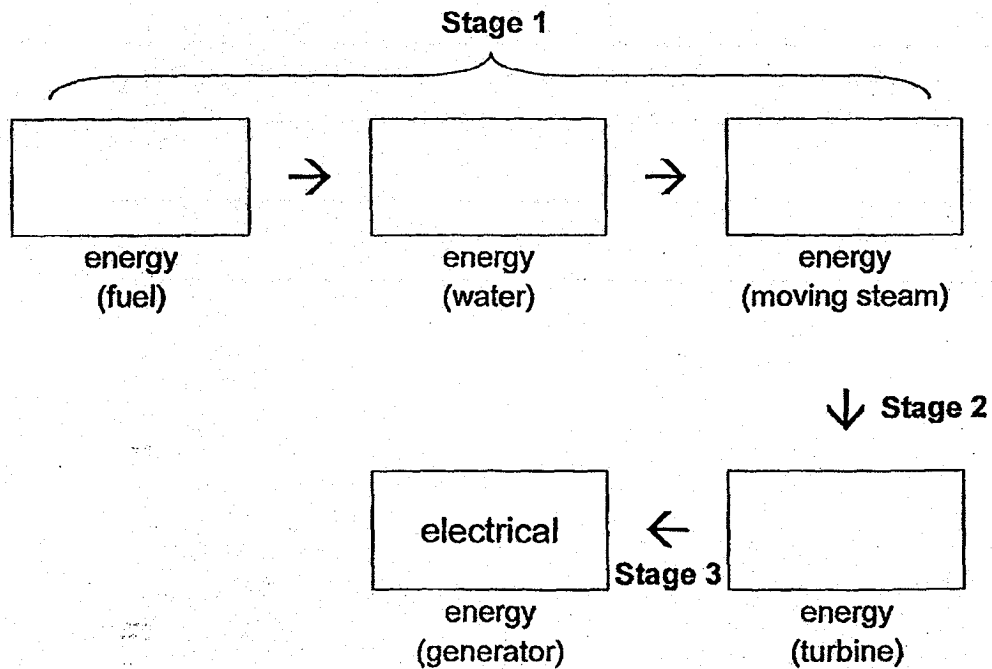

Marks :

/ 2

- (b) Randy carries out an experiment to see how a water wheel turns by water dripping from a cup with a hole at the base. The diagram below shows the experimental set-up.

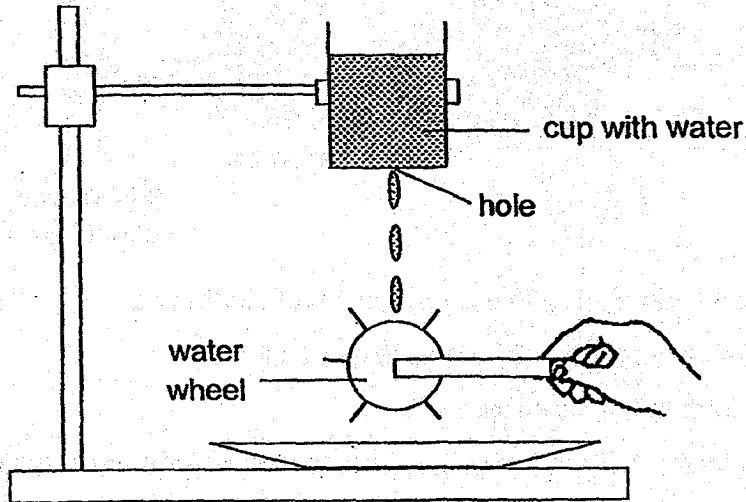

Explain why the water wheel will turn faster if the hole is made bigger. [2]

Marks :

12

31. Jamie tried to obtain clean water from sea water, using the set-up as shown below.

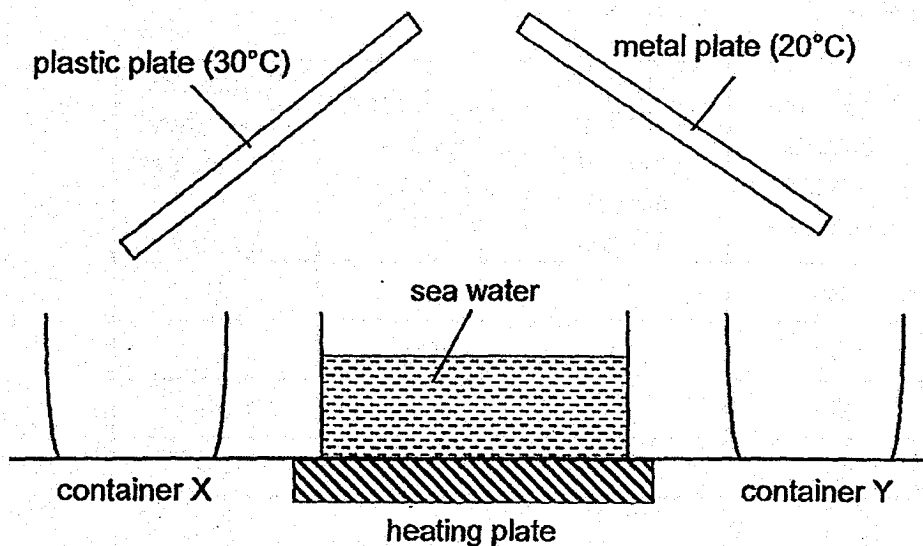

(a) State the process taking place on the surfaces of the plates which allowed water to be obtained. [1]

(b) During the first two minutes of the experiment, which of the containers, X or Y, would collect more water? Explain your answer. [2]

(c) Jamie observed that fewer water droplets formed on the metal plate after 10 minutes. Explain why this happened. [1]

Marks :

	/ 4
--	-----

32. (a) Farmer Kell had a plot of plants in his farm.

He recorded his observations of the plants over a period of 40 days in the table below.

Days	Number of type A flowers observed	Number of fruits that grow from type A flowers	Number of type B flowers observed	Number of fruits that grow from type B flowers
10	20	0	35	0
20	50	0	55	0
30	80	0	75	30
40	90	0	95	50

(i) Based on Farmer Kell's observations, which type of flower A or B is female and which is male?

Female : _____

Male : _____

(ii) Farmer Kell always notices bees flying around the plants growing in his farm.

How are these bees helpful to the plants in their reproduction? [1]

Marks :

12

- (b) Fertilisation in flowering plants and human beings can be prevented by certain methods.

Cutting the flower at X, as shown, prevents fertilisation of the flower.

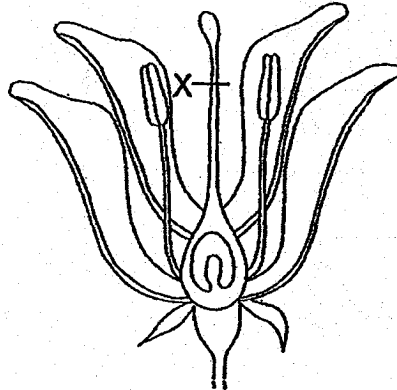

reproductive system A

Unlike reproductive system A, reproductive system B must be cut at two points, Y and Z, as shown to prevent fertilisation from taking place.

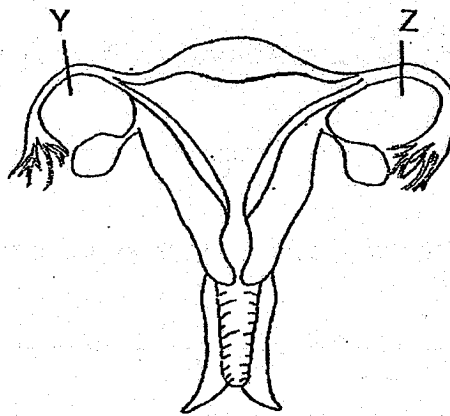

reproductive system B

Explain why two cuts have to be made in reproductive system B while only one cut is needed for reproductive system A to prevent fertilisation.

[1]

Marks :

1/1

33. The diagram below shows how blood flows in our body. Arrows W, X, Y and Z represent the movement of blood. Boxes J and K represent two organs.

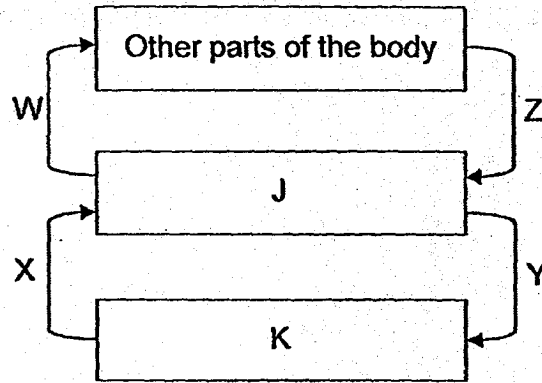

- (a) Name the two organs which J and K represent. [1]

J: _____ K: _____

- (b) Which two arrows represent the movement of blood rich in oxygen? [1]

- (c) Name the organ in which digested food is absorbed into the blood. [1]

Marks :

- (d) The graph below shows the change in the amount of undigested food as it passed through some parts of the human digestive system after a meal when the food was chewed before swallowing.

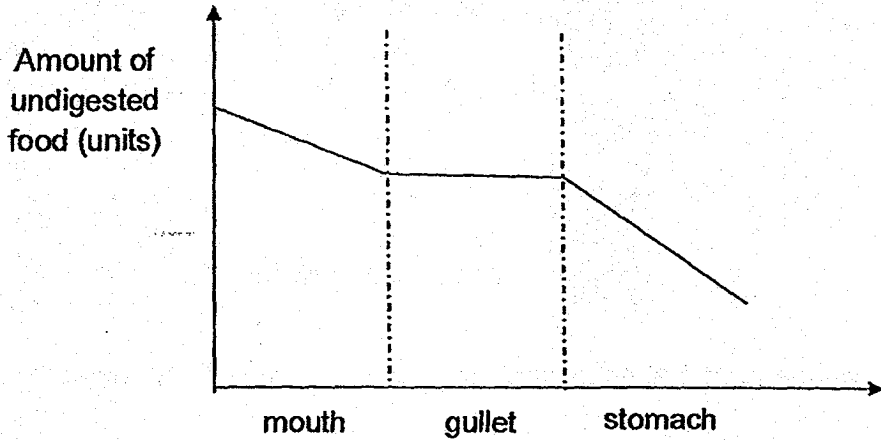

Two additional lines, P and Q, are shown in the graph below.

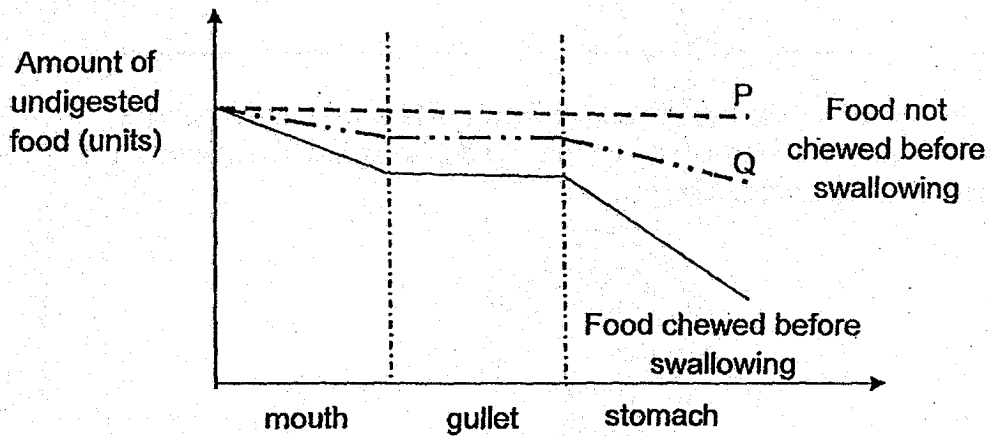

Which line, P or Q, shows the change in the amount of undigested food in the various parts of the digestive system after a meal when the food was not chewed before swallowing? Explain your answer. [1]

Marks : / 1

34. The diagram below shows a stalk of white flower in a beaker of red coloured water.

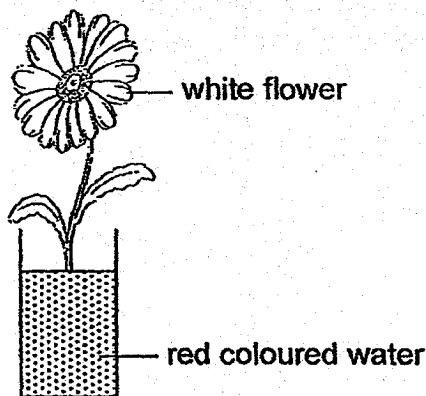

After 24 hours, it was observed that the whole stalk of white flower had turned red.

- (a) Explain why the stalk of white flower turned red. [1]

-
- (b) A section of the stalk of the above flower was examined under the microscope. The parts that appeared red in the stalk are shown as shaded in the diagram below.

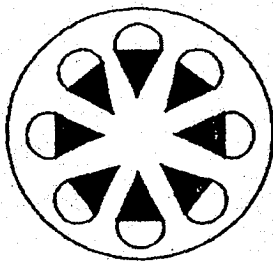

What do the shaded parts represent in the stalk? [1]

-
- (c) Name the part in the human body that has the same function as the parts shaded in (b). [1]

Marks :

/ 3

- (d) Aphids have a specialized mouthpart called proboscis, as shown in the diagram below.

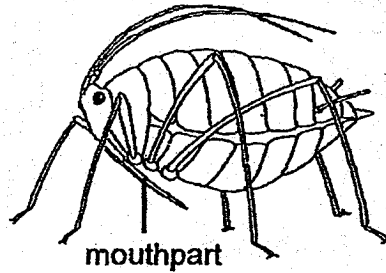

They tend to use their proboscis to pierce into the stem of plants more often during the day, when plants make food, than at night.

Explain this behaviour of the aphids.

[1]

Marks :

/ 1

35. Charles has built an automatic electric circuit breaker which helps him to switch off his water pump when the water level reaches the limit in his aquarium.

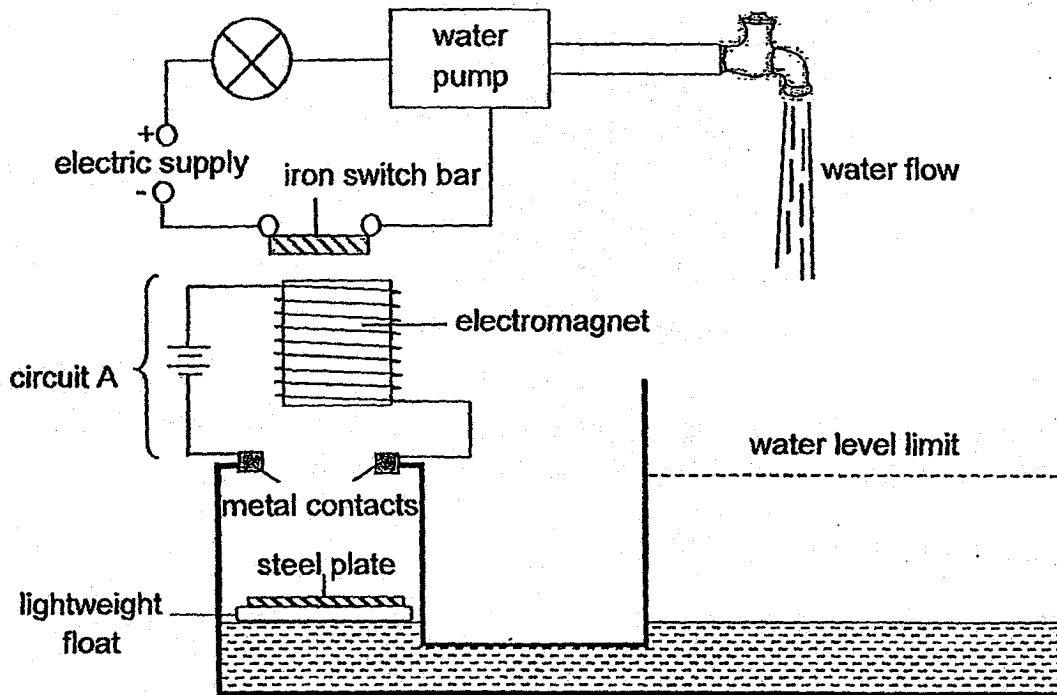

- (a) State a property of the iron switch bar which allows the circuit connected to the water pump to work [1]

- (b) Describe how the water pump is switched off when the water level in the aquarium gets too high. [2]

Marks : / 3

- (c) At a later time, Charles observes that even though the water level has dropped, the steel plate remains at the metal contacts. As a result, he is not able to start the water pump to refill the tank.

Explain why this happens.

[2]

Marks :

12

36. (a) Angus put a balloon in a bottle and tried to inflate the balloon by blowing air into it, as shown in the diagram.

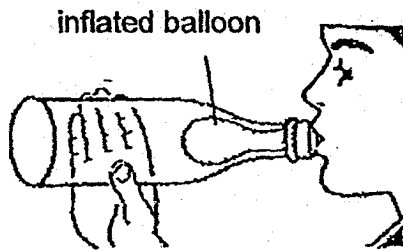

- (i) Explain why Angus could inflate the balloon at first. [1]

- (ii) Explain why Angus could only inflate the balloon a little even though there was enough space in the bottle. [1]

Marks :

12

- (b) Angus conducted another experiment to find out if soil contains air. First, he placed a thin plastic sheet on a glass completely filled with water and inverted the glass.

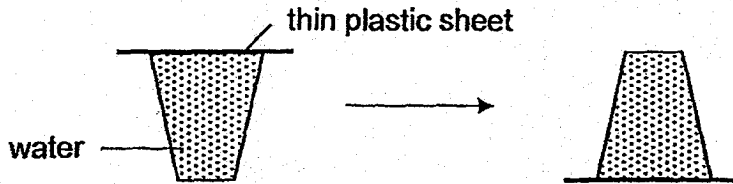

He then placed the inverted glass on top of a cup of soil. When he removed the sheet, water entered the soil and bubbles appeared in the water.

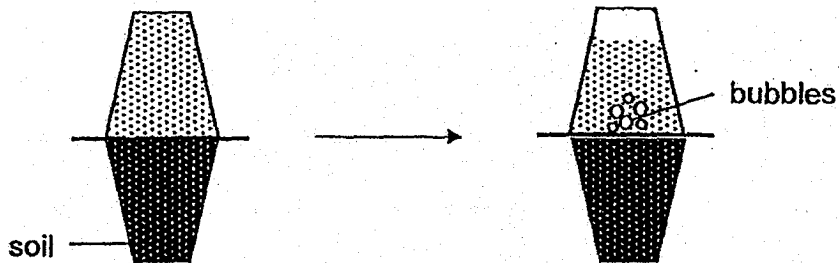

Explain why the bubbles appeared in the water.

[2]

Marks :

12

37. Ching Yee prepared a simple set-up as shown below to find out how a change in a variable would affect the shadow formed by the object.

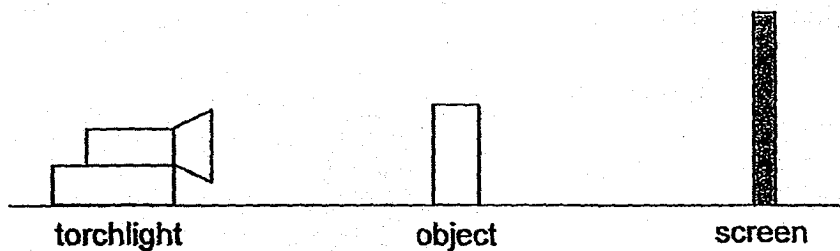

The graph below shows the results of her experiment due to the change in the variable.

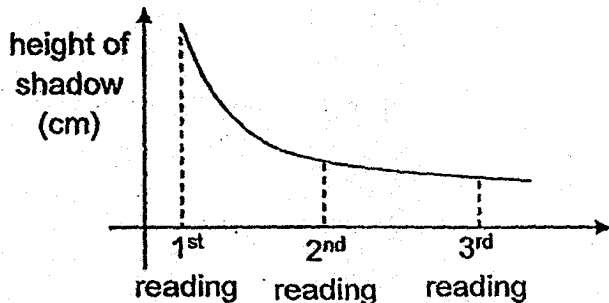

- (a) Based on the graph, state what was the variable that Ching Yee had changed. [1]

Marks :

	/ 1
--	-----

- (b) A light sensor was placed behind different materials to record the amount of light passing through them.

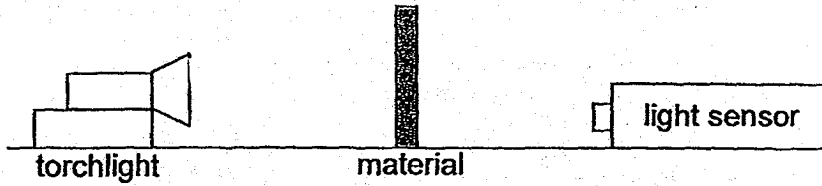

The results are as shown below.

Material	Amount of light recorded (units)
W	0
X	156
Y	300

Which of the materials is most suitable for making the screen used in the experiment? Explain your answer [2]

Marks :

12

38. Jack conducted an experiment using two cups W and X made of different materials A and B respectively. He filled both cups with the same volume of tap water at a temperature of 25°C and placed them each into a basin of hot water at 90°C.

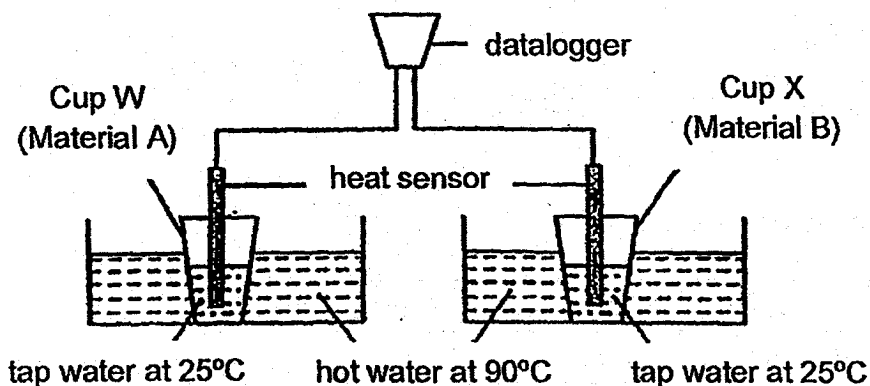

Jack then used a heat sensor to measure and record the temperature of water inside cups W and X for ten minutes. The results are shown in the graph below.

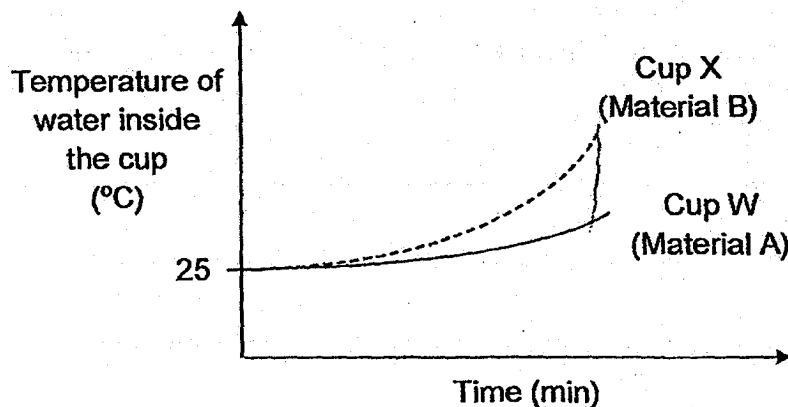

- (a) Which material, A or B, is a better conductor of heat? Explain your answer. [1]

- (b) If Jack wanted to keep his drink cold for the longest time, which cup would he choose to use? Explain your answer. [1]

Marks : 12

39. Lucy hung a strong button magnet using a wire and allowed the magnet to swing freely as shown in the diagram below.

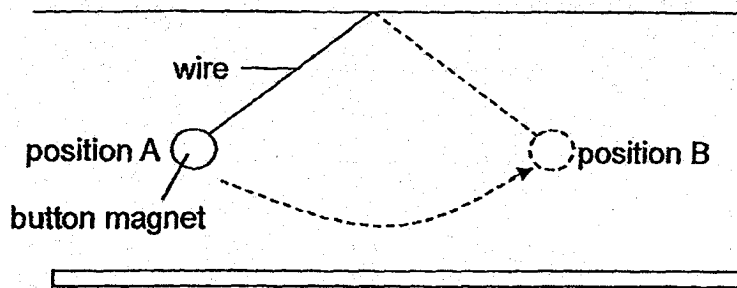

She recorded the time taken for the magnet to swing from position A to B in the table shown below.

Time taken for ball to swing from A to B (s)			
Try 1	Try 2	Try 3	Average
1.0	1.3	1.6	1.3

She placed an object Z below the swinging magnet and repeated the experiment again. The results taken for the magnet to swing from position A to B was recorded again. The magnet came to a stop at the resting position as shown.

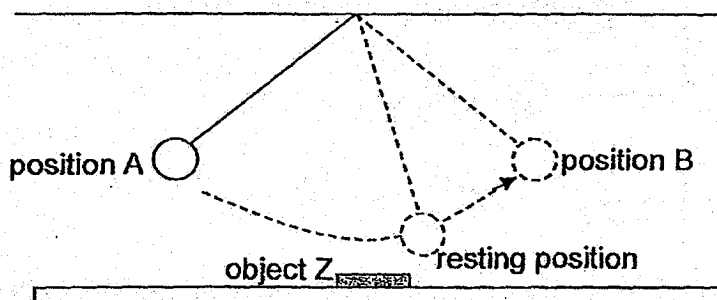

Time taken for ball to swing from A to B (s)			
Try 1	Try 2	Try 3	Average
2.5	2.3	2.7	2.5

- (a) State an example of the material in which object Z could be made of [1]

- (b) Explain why there was a change in the time required for the magnet to swing from position A to position B. [1]

Marks :

12

40. John has a toy airplane. When it is switched on, an indicator bulb lights up and the motor moves the toy at the same time. The diagram shows how the electric components are connected in the circuit.

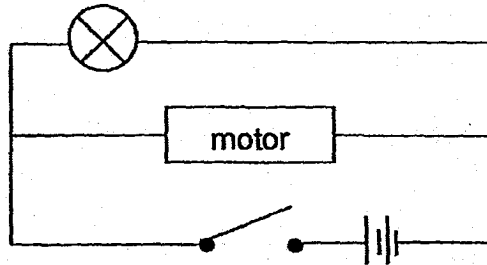

- (a) Based on the diagram shown above, give a reason why the motor continues to work even though the bulb is fused. [1]

- (b) John decides to add two more light bulbs to the circuit at the locations marked with a cross.

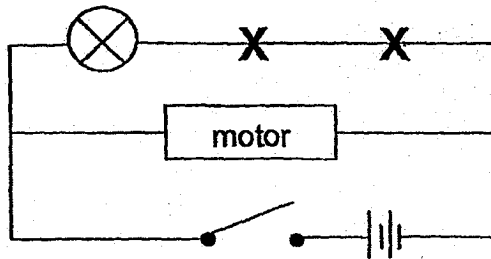

- Using the graph below, show how the brightness of the light bulb will change as he adds these bulbs one at a time. [1]

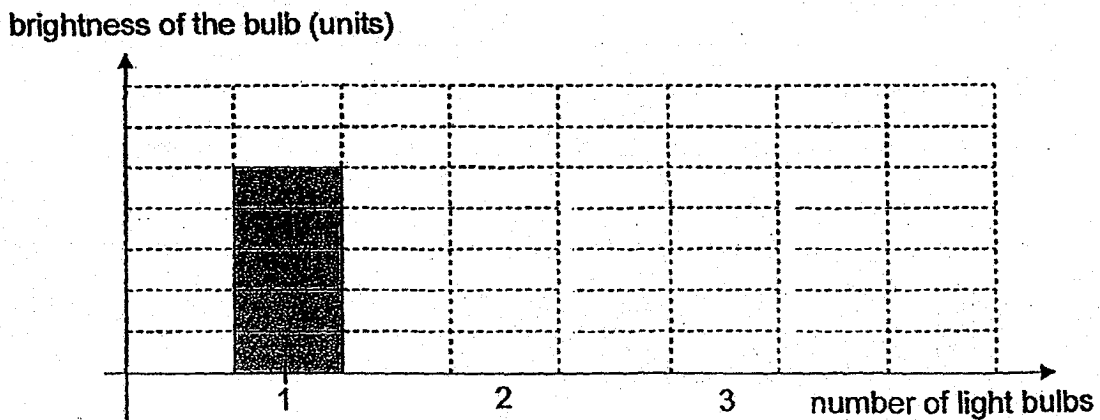

Marks : / 2

41. Jim conducted an experiment with three different materials P, Q and R of similar thickness. He wrapped each material over an empty beaker, as shown in the diagram below.

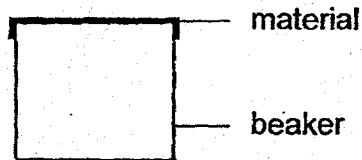

He then gently poured 200 ml of water onto each type of material. The graph below shows the volume of water observed in each beaker at the end of the experiment.

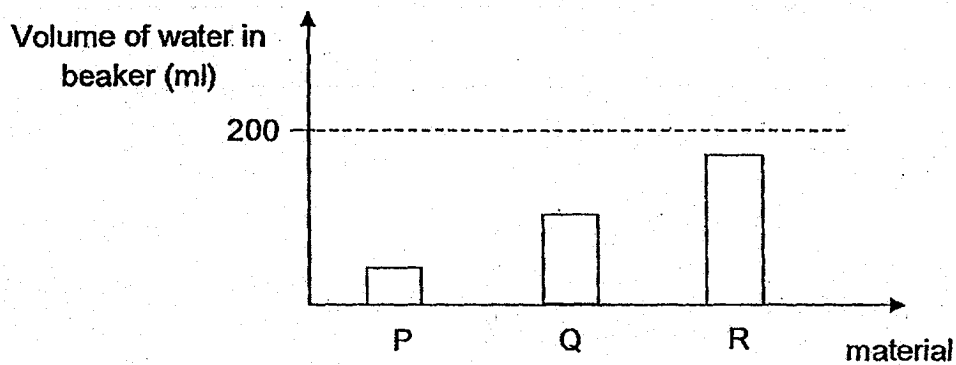

- (a) Explain why the amount of water collected in the three beakers were different. [1]

Marks : / 1

(b)

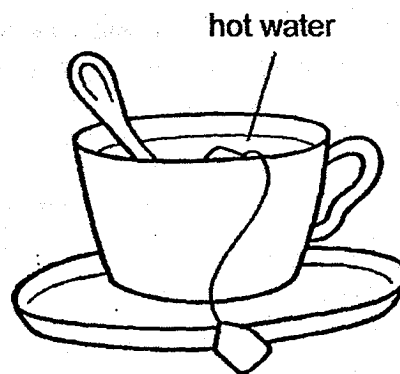
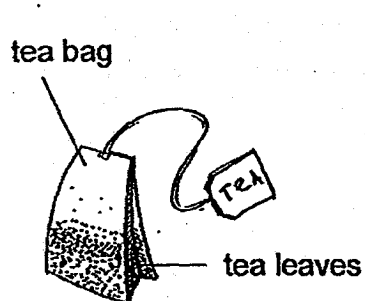

Based on the above experiment, explain which material is the most suitable to be used to make a tea bag for making a cup of tea. [1]

~ END OF PAPER ~

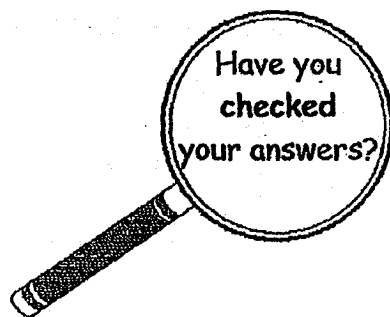

Marks :

	/ 1
--	-----

SCHOOL : MAHA BODHI PRIMARY SCHOOL
LEVEL : PRIMARY 5
SUBJECT : SCIENCE
TERM : 2018 SA2

SECTION A

Q 1	Q2	Q3	Q4	Q5	Q6	Q7	Q8	Q9	Q10
2	4	4	1	2	2	1	2	1	2
Q 11	Q12	Q13	Q14	Q15	Q16	Q17	Q18	Q19	Q20
4	4	2	3	3	3	3	1	2	2
Q 21	Q22	Q23	Q24	Q25	Q26	Q27	Q28		
1	2	2	2	3	4	2	4		

SECTION B

Q29)	<p>a) i) Gravitational Potential – Kinetic ii) There was not enough kinetic energy as some energy was lost as heat and sound.</p> <p>b) i) Material Q. Material Q took a longer time to reach 100 C so if it was used to make the sleeve, Material Q would take a longer time to become the same temperature as the hot tea. ii) Left hand</p>
Q30)	<p>a) Chemical Potential – Heat – Kinetic – Kinetic</p> <p>b) More water will flow out. There is a greater mass of water resulting in more potential energy in the water. More energy is converted to kinetic energy to potential energy in the water which is transferred to the water wheel to make it turn faster.</p>
Q31)	<p>a) Condensation</p> <p>b) Container Y. The metal plate was colder, so water vapour can lose more heat to it. The rate of condensation is higher.</p>

	<p>c) The metal plate became warmer. Less water vapour could lose heat to it.</p>
Q32)	<p>a) i) Female : B Male : A ii) The bees help to carry pollen grains from the anther to stigma of a flower, helping plants in pollination</p> <p>b) System B has two ovaries but system A only has one.</p>
Q33)	<p>a) J : Heart K : Lungs</p> <p>b) Arrows W and X</p> <p>c) Small intestines</p> <p>d) Line Q. The mouth and the stomach would digest the food so the amount of undigested food should decrease.</p>
Q34)	<p>a) The water-carrying tubes in the stalk transported the red-coloured water to the flower.</p> <p>b) Water-carrying tubes</p> <p>c) Blood vessel</p> <p>d) They feed on food made by the leaves which is transported by the food-carrying tubes in the stem.</p>
Q35)	<p>a) The iron switch bar is a conductor of electricity.</p> <p>b) When the water level is too high, the steel plate would float up and would connect the metal contacts together. Electric current would flow through the coils of wire around the magnet stronger to attract the iron switch bar so the circuit where the water pump is placed will become an open circuit and the water pump will stop.</p> <p>c) The steel plate is attracted by the electromagnet, causing circuit A to remain closed. The iron switch bar is still attracted to the electromagnet even if the water level drops, causing the water pump circuit to be enable to be closed.</p>
Q36)	<p>a) i)The air in the bottle could be compressed. ii)Air in the bottle could not be compressed further.</p> <p>b) Water occupied the space in between the soil. Air in the soil was pushed out, forming the bubbles.</p>
Q37)	<p>a) The distance between the object and the torchlight.</p>

	<p>b) Material W. No light could pass through W. The shadow of the object will be the clearest.</p>
Q38)	<p>a) B. The temperature of the water in the cup increased faster.</p> <p>b) Cup W. It is made of a material which is a poorer conductor of heat. The cold drink would gain heat from the surroundings slower.</p>
Q39)	<p>a) Iron</p> <p>b) Z is a magnet. It repelled the button magnet.</p>
Q40)	<p>a) Electric current can still flow through the motor as the circuit is still a closed circuit.</p> <p>b)</p>
Q41)	<p>a) The three beakers absorb different amounts of water.</p> <p>b) Material R. It allows the most water to pass through it.</p>

