



PEI HWA PRESBYTERIAN PRIMARY SCHOOL
SEMESTRAL ASSESSMENT 2
PRIMARY 4
SCIENCE
(BOOKLET A)

29 OCTOBER 2018

Name: _____ ()

Class: Teamwork _____

Total time for Booklets A and B: 1 h 45 min

INSTRUCTIONS TO CANDIDATES

1. Write your Name, Class and Register No. in the spaces provided above.
2. DO NOT turn over this page until you are told to do so.
3. Follow all instructions carefully.
4. Answer all questions.
5. Shade your answers on the Optical Answer Sheet (OAS) provided.

This booklet consists of 18 printed pages, excluding the cover page.

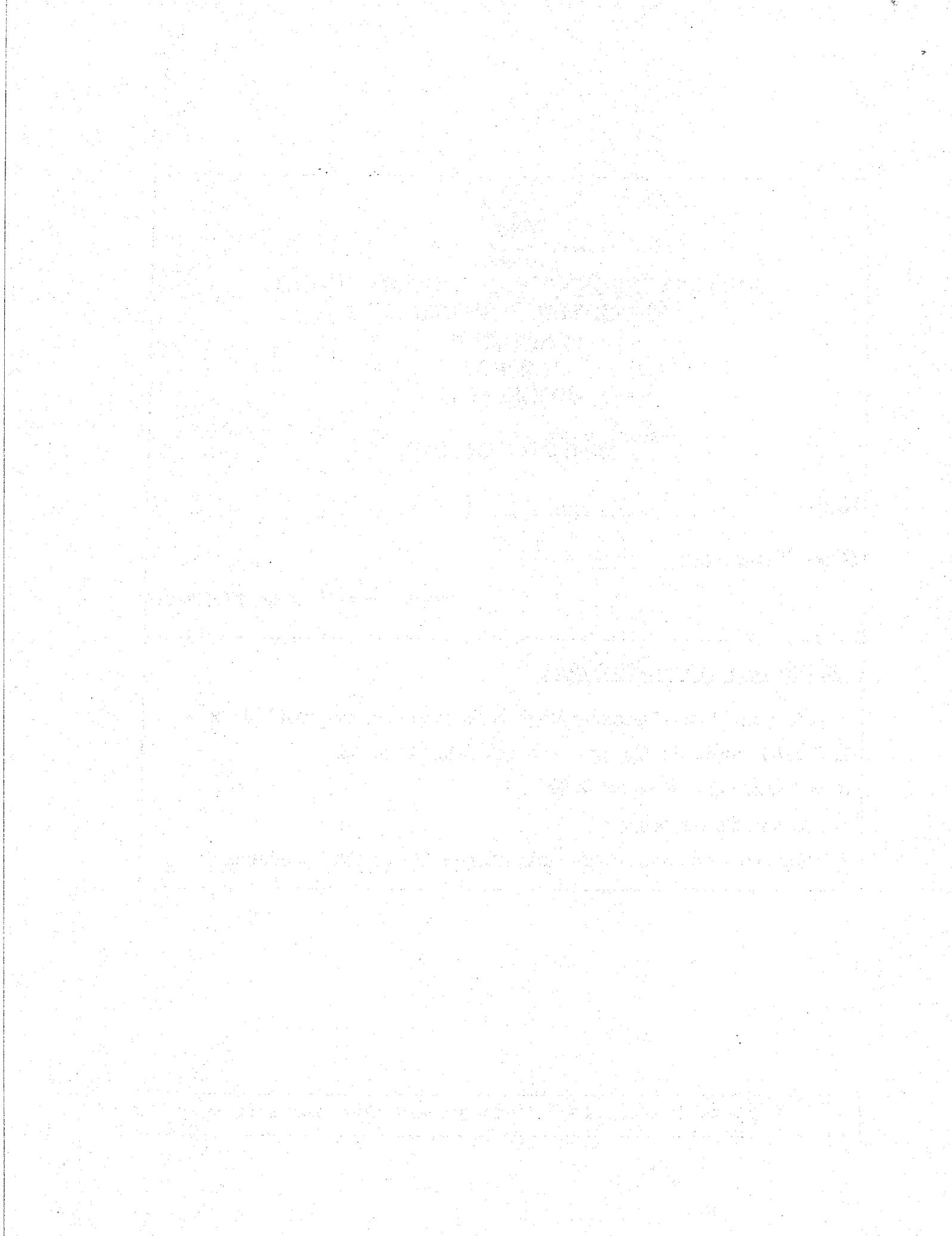

For each question from 1 to 28, four options are given. One of them is the correct answer. Make your choice and shade the oval (1, 2, 3 or 4) on the Optical Answer Sheet provided. (56 marks)

1. Which one of the following shows the correct order when food moves through some parts of the digestive system?

(1)

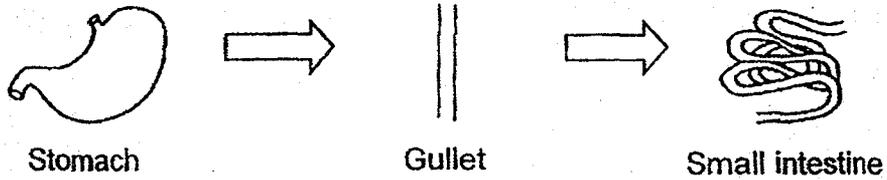

(2)

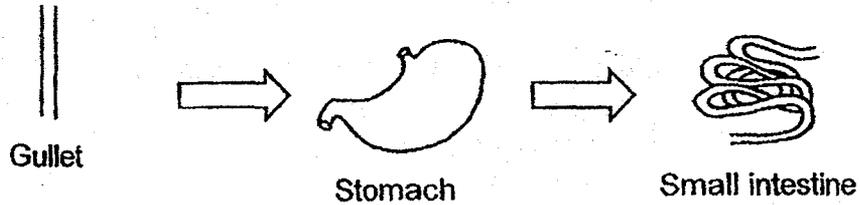

(3)

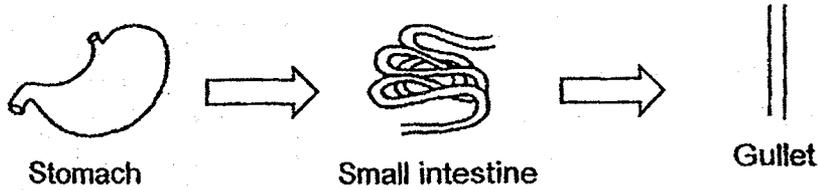

(4)



2. The diagram below shows a young plant.

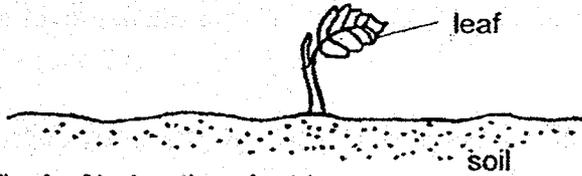

The leaf helps the plant to _____.

- (1) make food
- (2) grow upright
- (3) absorb water
- (4) absorb nutrient

3. The table below shows how some living things can be grouped.

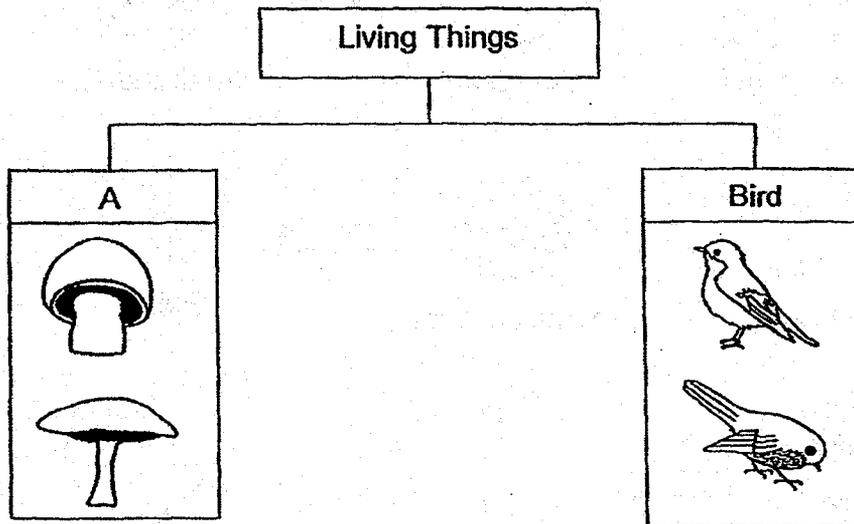

Which one of the following is the most suitable heading for group A?

- (1) Fungi
- (2) Insects
- (3) Bacteria
- (4) Mammals

4. Which of the following objects is **not** made of waterproof material?

(1)

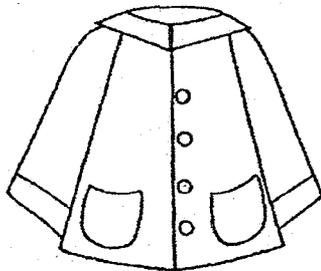

Raincoat

(2)

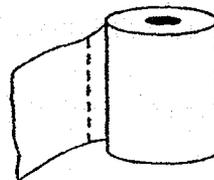

Toilet Paper

(3)

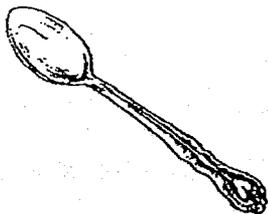

Metal Spoon

(4)



Rubber Gloves

5. Shirley has 4 similar cups made of different materials. She filled the 4 cups with the same amount of hot tea at 70°C. They were left to cool for 1 hour. She recorded the temperature of the hot tea as shown in the table below.

Material	Temperature of tea at first (°C)	Temperature of tea after 1 hour (°C)
A	70	60
B	70	30
C	70	40
D	70	54

Based on the results of her experiment, which material, A, B, C or D, is most suitable for making a lunch box that can keep food warm the longest?

- (1) A
- (2) B
- (3) C
- (4) D

6. Sam made the following observations on the life cycle of an animal.

- There are three stages in the life cycle.
- The young looks like the adult.

Which animal was Sam observing?

- (1) Frog
- (2) Beetle
- (3) Butterfly
- (4) Cockroach

7. Diagrams A, B, C and D show the various stages in the life cycle of a mosquito.



A

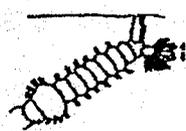

B

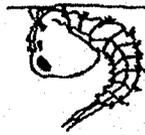

C



D

Which of the following correctly shows the life cycle of a mosquito?

(1)

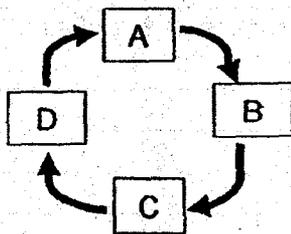

(2)

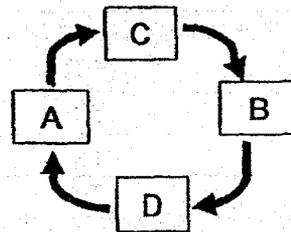

(3)

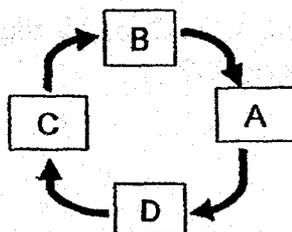

(4)

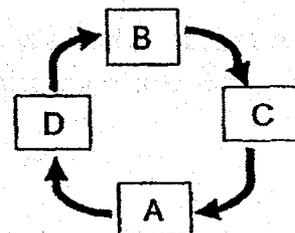

8. Study the classification chart below.

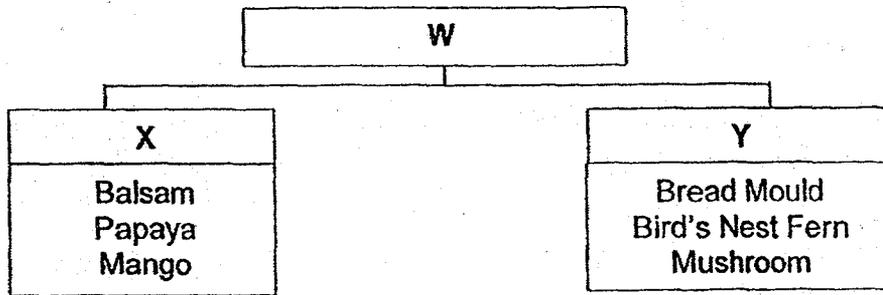

Which one of the following best represents W, X and Y in the classification chart above?

	W	X	Y
(1)	Plants	Reproduce by seeds	Reproduce by spores
(2)	Living Things	Flowering Plants	Non-Flowering Plants
(3)	Plants	Non-Flowering Plants	Flowering Plants
(4)	Living Things	Reproduce by seeds	Reproduce by spores

9. The diagram shows the different stages of the growth of a bean seed.

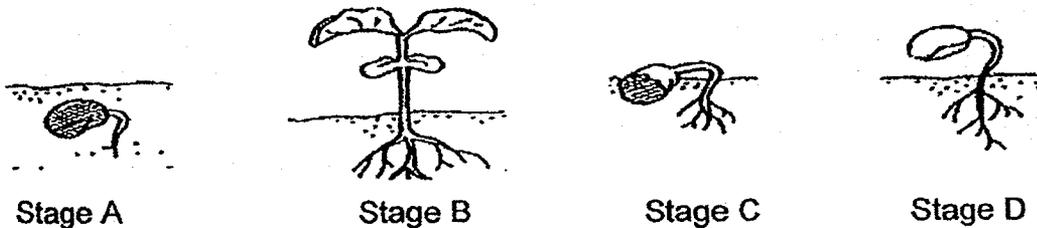

At which stage (A, B, C, or D) does it need air, water and sunlight?

- (1) A
- (2) B
- (3) C
- (4) D

10. The diagrams below show 4 set-ups using similar types of beans and containers placed in a room at different temperatures.

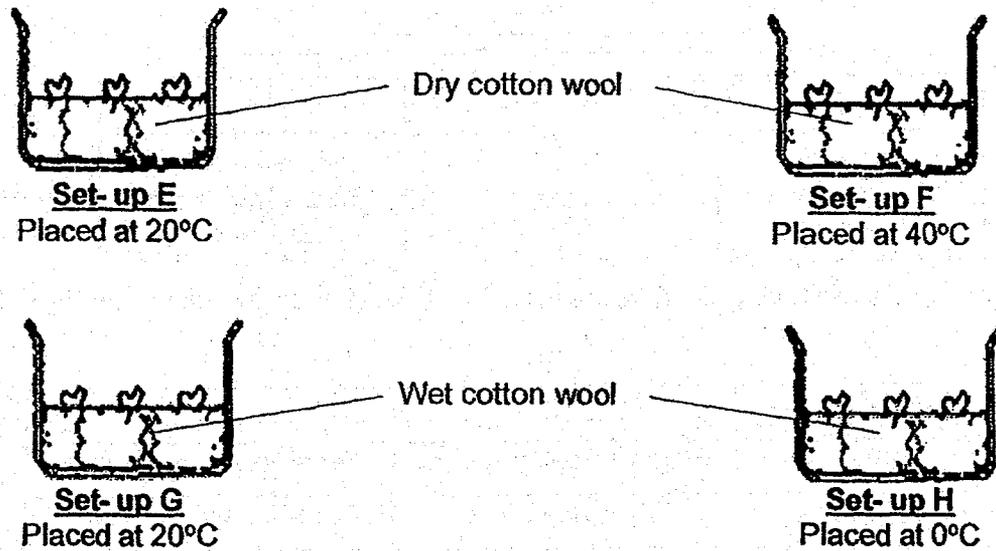

Which two set-ups should James use to compare if he wants to find out how temperature affects the growth of the bean seeds?

- (1) E and F
- (2) E and G
- (3) F and H
- (4) G and H

11. Henry dropped three objects, X, Y and Z into a tank of water as shown in the diagram below.

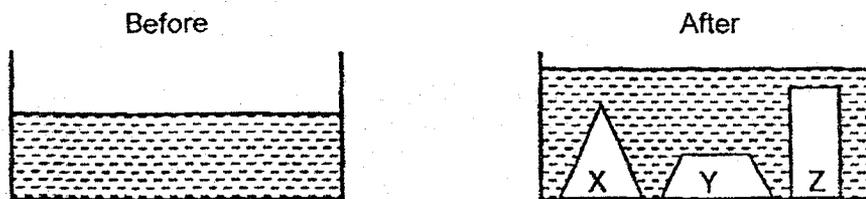

Based on the diagram above, he made a few conclusions about Objects X, Y and Z:

- A They occupy space.
- B They have the same mass.
- C They have the same volume.
- D They do not have a definite volume.

Which of the following conclusion(s) is/are true?

- (1) A only
 - (2) A and C only
 - (3) B and C only
 - (4) B and D only
12. Mr Kong set up an experiment as shown. He poured some water into the funnel and observed that just a few drops of water flowed into the flask. A few minutes later, he observed that the water from the funnel stopped flowing into the flask.

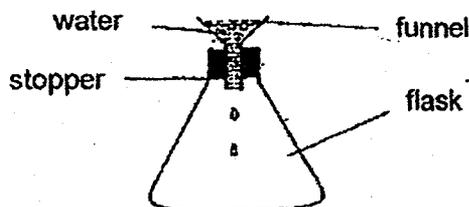

Sam carried out the same experiment. However, when he poured the water into the funnel, he found that the water could flow into the flask easily.

Which of the following could be a reason why Sam's result is different from Mr Kong's?

- (1) He used a smaller flask.
- (2) He used a longer funnel.
- (3) He did not fit the stopper tightly into the flask.
- (4) He poured the water into the flask more quickly than Mr Kong.

13. The reading on the weighing scale shows that the mass of the grapes is _____ kg.

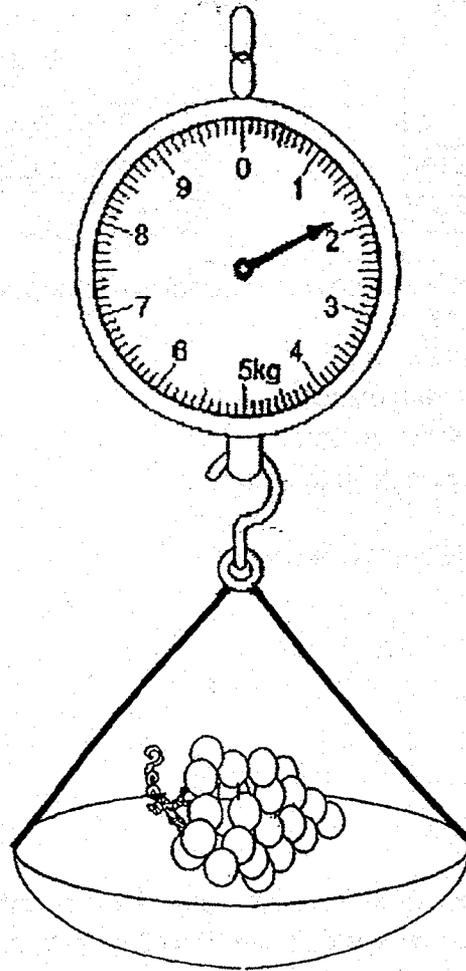

- (1) 1.5
- (2) 1.8
- (3) 2.0
- (4) 2.2

14. The diagram below shows 4 containers of different volume.

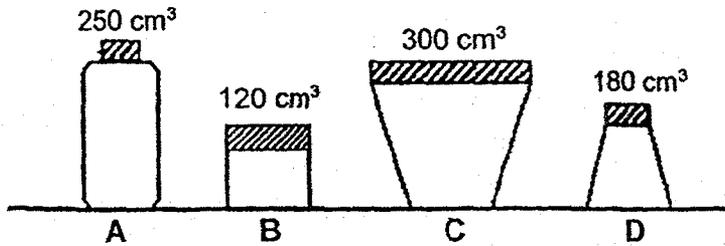

Which of the above container(s) A, B, C and D can hold 200 cm^3 of air when air is pumped into them?

- (1) C only
- (2) A and C only
- (3) A, C and D only
- (4) A, B, C and D

15. Zoe used a piece of clay to make a model of a car. She then used the same piece of clay that was used to make the model of car and re-molded it into a sailboat.

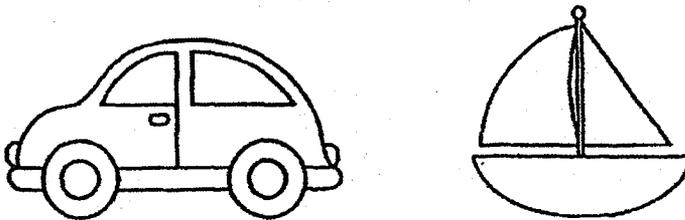

The two models she made have the same _____.

- A Mass
 - B Shape
 - C Volume
-
- (1) C only
 - (2) A and C only
 - (3) B and C only
 - (4) A, B and C

16. Object F was attracted to a magnet, as shown in the figure below.

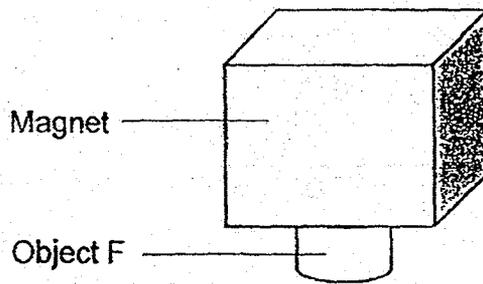

Object F is made of _____.

- (1) Iron
- (2) Wood
- (3) Plastic
- (4) Rubber

17. Jay placed a toy truck on a board. He used a magnet to move the toy truck from one point to another.

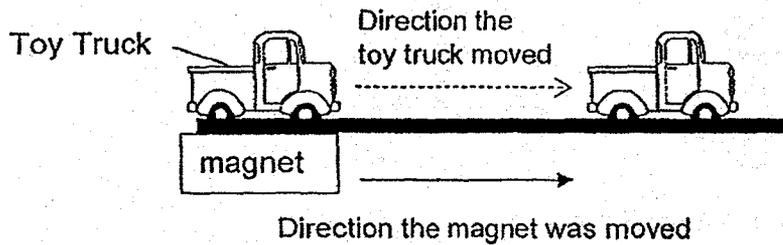

What material is the toy truck made of?

- (1) Steel
- (2) Plastic
- (3) Rubber
- (4) Aluminium

18. The diagram shows Magnet R and Magnet T when placed together

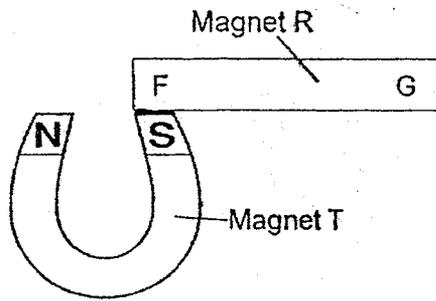

Which one of the following shows the correct position of Magnet R when it is placed with two other magnets?

- (1)
- (2)
- (3)
- (4)

19. Look at the picture below.

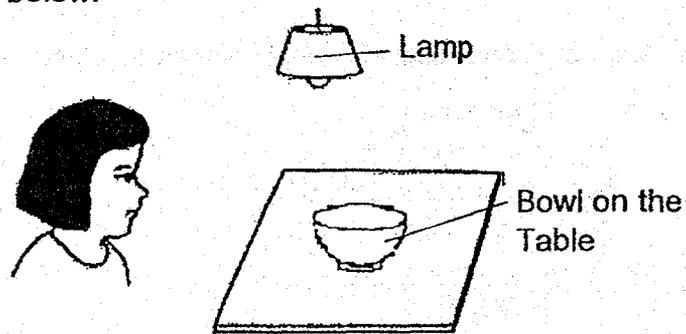

Which one of the following explains why Lindy can see the bowl on the table?

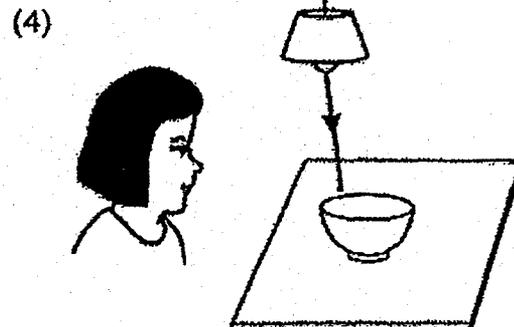
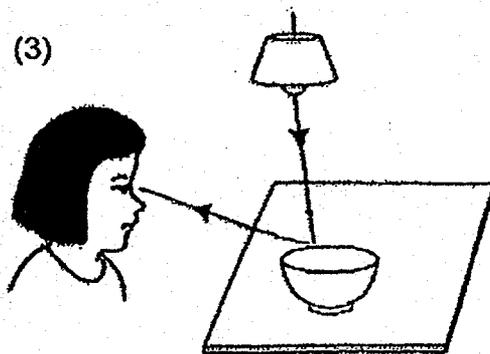
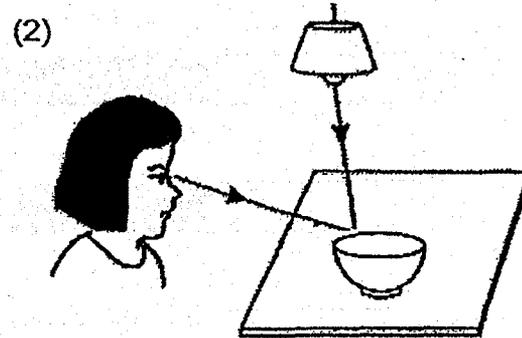
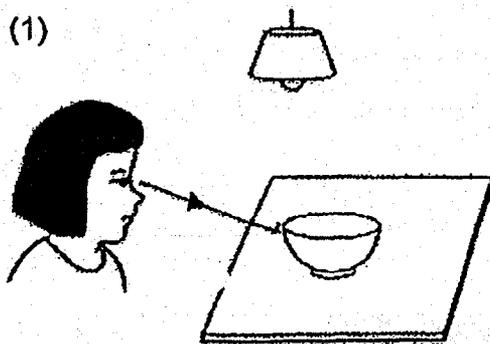
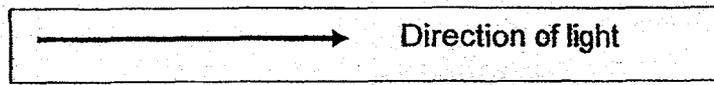

20. The diagram below shows 2 mirrors that were placed inside a connection pipe.

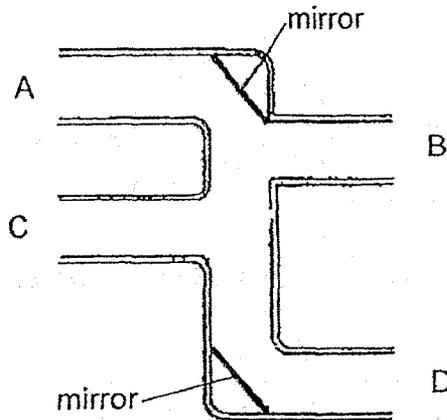

Which of following pair shows the correct position of an object which could be seen by the eye at the various positions?

	Position of Object	Position of the Eye
(1)	A	B
(2)	B	C
(3)	D	A
(4)	C	D

21. Kay was given a cone as shown below and she shone a torchlight at it at different angles to get different shadows.

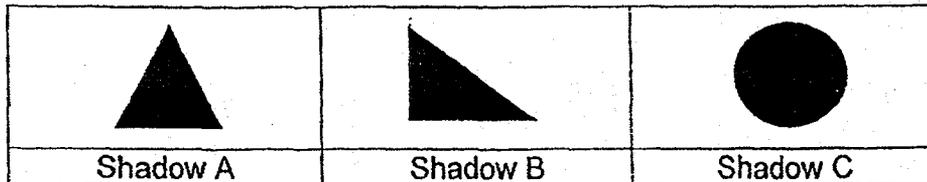
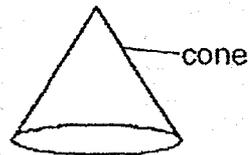

Which of the following shadows do you think Kay is likely to observe?

- (1) A only
- (2) A and C only
- (3) B and C only
- (4) A, B and C

22. The diagram below shows three soccer balls, A, B and C, placed at different distances in front of a screen. A light source was switched on and the shadows of A, B and C were cast on the screen.

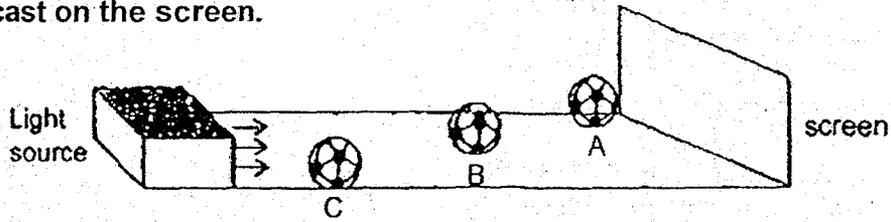

The shadows cast on the wall are as shown below. The shadows of balls A, B and C are of the same size.

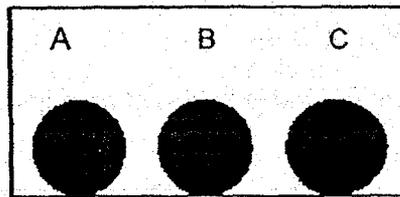

Based on the shadows seen on the screen, which one of the following shows the correct sizes of Balls A, B and C ?

	Ball A	Ball B	Ball C
(1)			
(2)			
(3)			
(4)			

23. The driver uses the rear view mirror in a car as shown below to see the lamp post behind him.

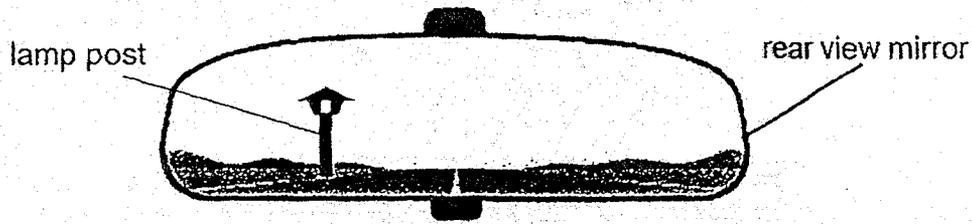

Which one of the following statements best explain why the driver could see the lamp post?

- (1) The rear view mirror is a light source.
 - (2) The mirror reflects the light coming from the lamp post.
 - (3) The lamp post reflects the light coming from the mirror.
 - (4) The mirror blocks off the light coming from the lamp post.
24. Andy carried out the experiment below in a dark room. Materials A, B, C, and D were arranged in a straight line.

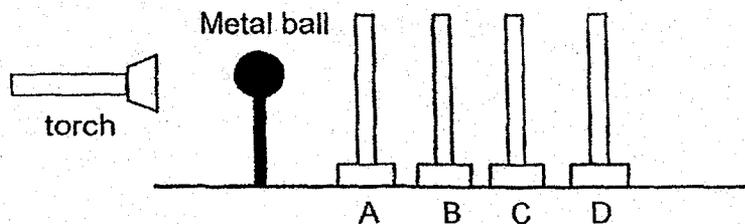

He shone a torch at the metal ball and he observed the following image formed on screen D.

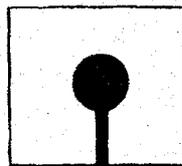

Based on the results of his experiment, which material(s) is/are suitable to be used to make a car window?

- (1) D only
- (2) C and D only
- (3) A, B and C only
- (4) A, B, C and D

25. The diagram below shows a portion of the train tracks with gaps.

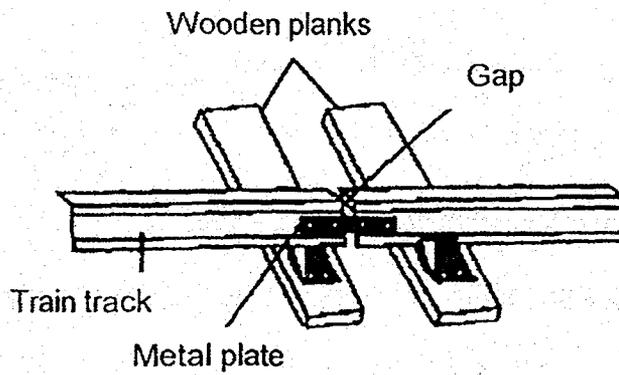

The gaps in the train tracks allow the tracks to _____.

- (1) expand on hot days
- (2) contract on hot days
- (3) expand on cold days
- (4) contract on cold days

26. Jen wants to measure the temperature of cold water in a beaker. Which one of the following diagrams shows the correct position of the thermometer when taking the temperature reading?

(1)

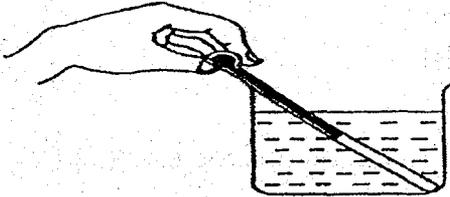

(2)

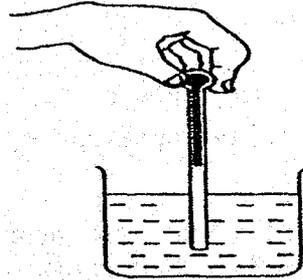

(3)

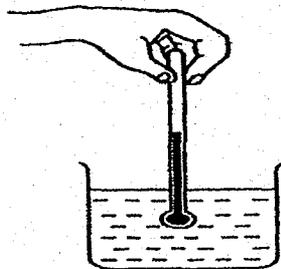

(4)

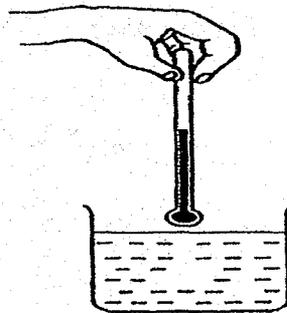

27. Mrs Tan found it difficult to open the metal lid of a glass jar which she had just removed from the set-up shown below.

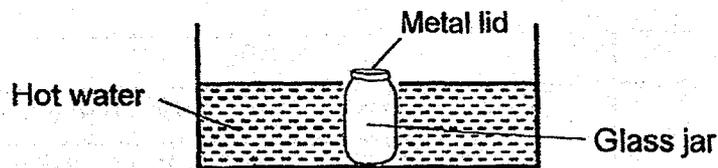

Which of the following reasons explain why this is so?

- (1) The metal lid expanded more than the glass jar.
- (2) The glass jar expanded more than the metal lid.
- (3) The metal lid contracted more than the glass jar.
- (4) The glass jar contracted more than the metal lid.

28. The diagram below shows two covered containers X and Y of the same size left in the sun for 30 minutes.

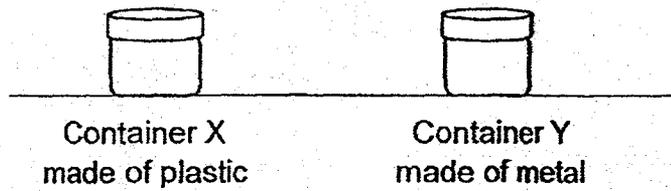

The temperature of both containers were taken after 30 minutes and represented by Line A and Line B as shown in the graph below.

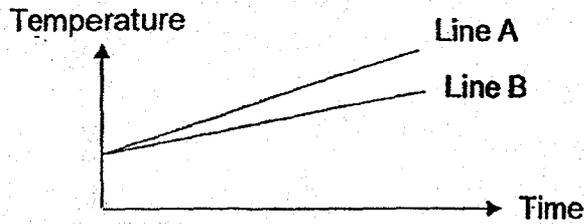

Line A represents the temperature of container (i) _____ because (ii) _____.

Which one of the following best describe the blanks above?

	(i)	(ii)
(1)	X	plastic loses heat faster than metal
(2)	X	metal gains heat faster than plastic
(3)	Y	metal gains heat slower than plastic
(4)	Y	plastic gains heat slower than metal

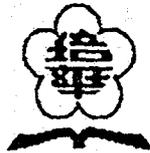

PEI HWA PRESBYTERIAN PRIMARY SCHOOL
SEMESTRAL ASSESSMENT 2

PRIMARY 4
SCIENCE
(BOOKLET B)

29 OCTOBER 2018

Name: _____ ()

Class: Teamwork _____

Parent's Signature

Total time for Booklets A and B: 1 h 45 min

INSTRUCTIONS TO CANDIDATES

1. Write your Name, Class and Register No. in the spaces provided above.
2. DO NOT turn over this page until you are told to do so.
3. Follow all instructions carefully.
4. Answer all questions.
5. Write all your answers in this booklet.

Marks (Booklet A) :	56
Marks (Booklet B) :	44
Total Marks (Booklets A & B) :	100

This booklet consists of 14 printed pages, excluding the cover page.

Write your answers to the questions 29 to 42 in the spaces provided.

The number of marks available is shown in brackets [] at the end of each question or part question. (44 marks)

29. Study the flowchart shown below.

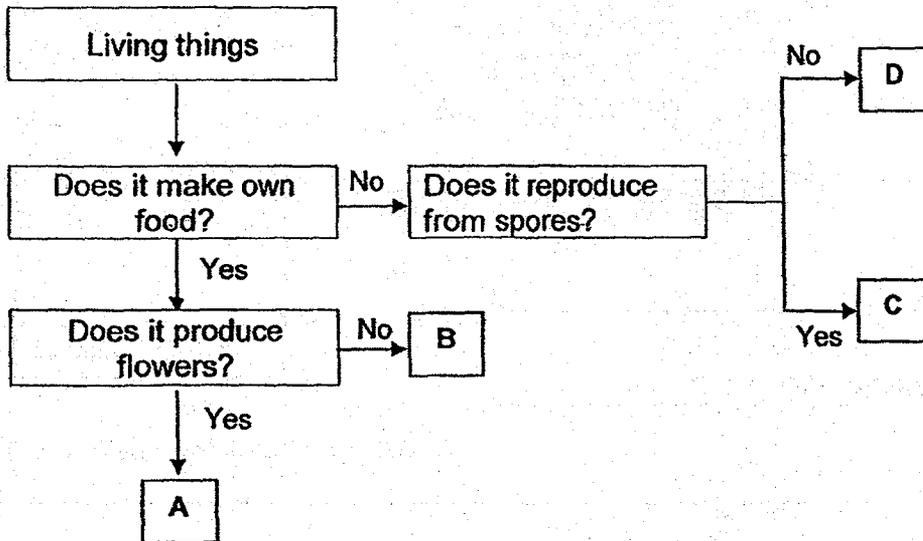

From the list given, identify the living things that best represent A, B, C and D. [2]

Bread Mould	Bird's Nest Fern	Cow	Rose Plant
-------------	------------------	-----	------------

A: _____

B: _____

C: _____

D: _____

30. Alex placed two different blocks, P and Q, into a beaker of water as shown below.

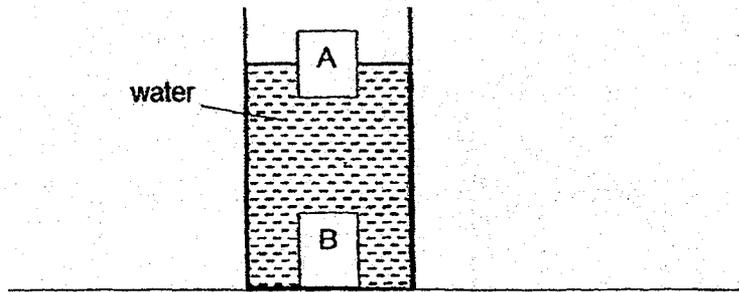

Block P was found at position A, while block Q was found at position B.

- (a) Fill in the blanks using the correct words in the box.

contracts	expands	floats	sinks
-----------	---------	--------	-------

This shows that block P _____ in water, and block Q [2]
_____ in water.

Alex placed an iron nail into the beaker of water similar to the one above.

- (b) At which position (A or B) would the iron nail most likely be? [1]

31. The diagram below shows the human digestive system.

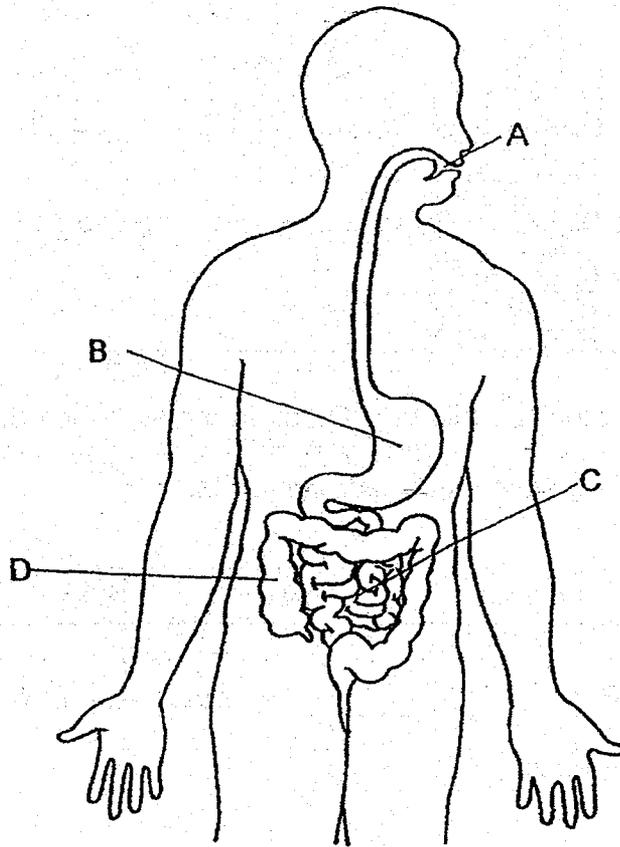

(a) Identify the part where: [2]

(i) digestion first takes place : _____

(ii) there is no digestion : _____

(b) At which part (A, B, C or D) is water being absorbed? [1]

32. The diagram below shows the stages in the life cycle of a grasshopper and a frog.

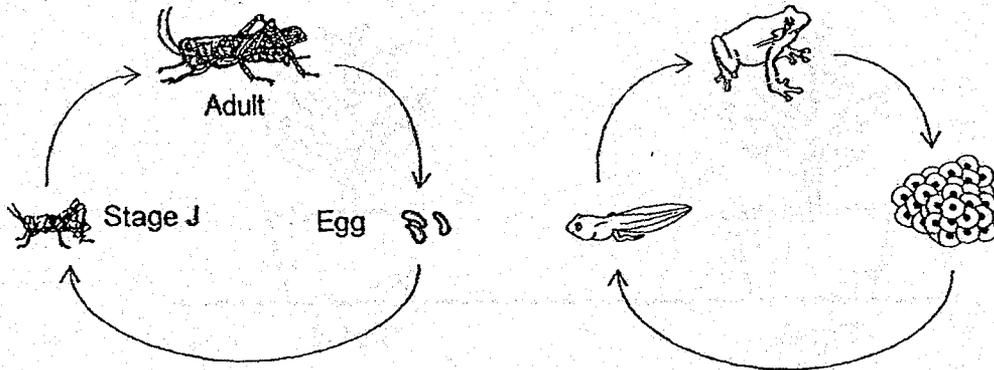

(a) Name stage J. [1]

(b) State one other animal that has a similar life cycle as a grasshopper. [1]

(c) Based on the diagrams above, state one difference between the life cycle of a frog and a grasshopper? [1]

33. Joe wanted to find out the effect of rice water on the growth of plants. He planted two identical plants in two pots A and B.

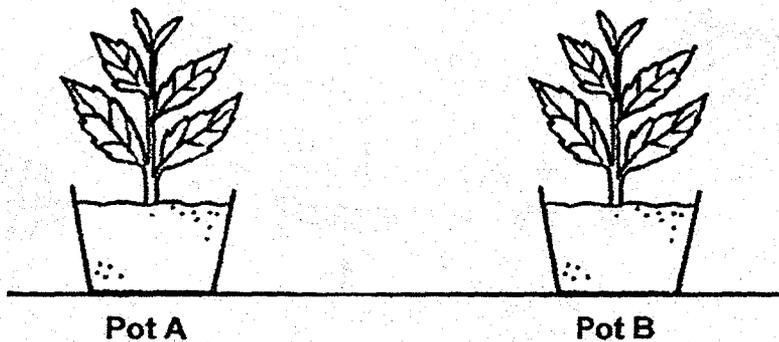

He set up Pot A with the conditions as shown in the table below.

Variable	Pot A
Type of soil	Garden soil
Amount of soil	2 kg
Type of water	Tap water
Amount of water	100 ml

- (a) For each variable, circle the correct condition that Joe have to set up in Pot B to ensure a fair test. [1]

Variable	Pot B
Type of soil	Garden soil / Sandy soil
Amount of soil	1 kg / 2 kg
Type of water	Tap water / Rice water
Amount of water	100 ml / 200 ml

- (b) Where should Joe placed Pots A and B so that the plants can grow healthily? [1]

- (c) Give a reason for your answer in (b). [1]

34. Ada wanted to measure the volume of object Z. She put object Z into a measuring cylinder containing 20 cm³ of water as shown below.

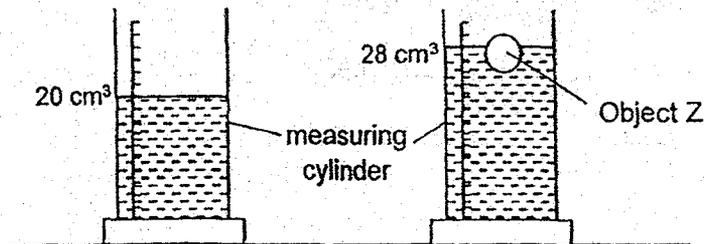

The water level rose to 28 cm³. Ada concluded that the volume of object Z is 8 cm³.

- (a) Ada's teacher told her that her result is incorrect. Give a reason why Ada's teacher said so. [1]

- (b) Number the following steps of the procedure, in the order (1, 2, 3 and 4), which Ada should carry out the experiment in order to get accurate results. [2]

Steps	Procedure
	Tie the metal bob to the object and put them into the measuring cylinder.
	Put the metal bob into the measuring cylinder. Measure the volume of the metal bob.
	Measure the volume of the metal bob and the object.
	Subtract the volume of the metal bob from the total volume of the metal bob and the object to get the volume of the object.

35. Ali placed two ring magnets, A and B, through a holder as shown below.

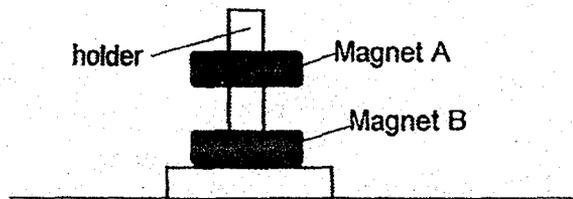

Based on the diagram given, fill in the missing blanks.

(a) The holder was made of wood and did not attract the magnets.

Wood is a _____ material. [1]

(b) Why was magnet A floating above magnet B?

Magnet B was _____ magnet A. [1]

36. Devi did an experiment with four different electromagnets, P, Q, R and S.

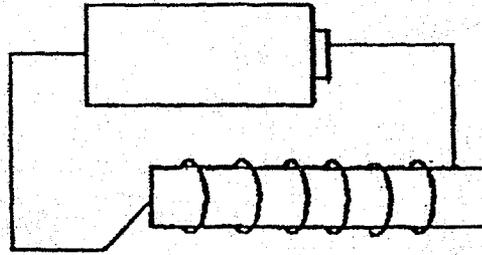

She placed each of them near some nails and recorded her observation in the table below.

Electromagnets	Number of batteries	Number of nails attracted
P	1	2
Q	2	4
R	3	6
S	4	10

(a) From the table above, what is the relationship between the number of batteries and the magnetism of the electromagnet? [1]

(b) Besides using more batteries, list 2 other ways that Devi could do to increase the magnetism of the electromagnet. [2]

(i) _____

(ii) _____

(c) State another way to make a magnet. [1]

37. Look at the pictures.

(a) Tick (✓) the sources of light.

[2]

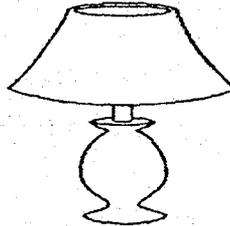
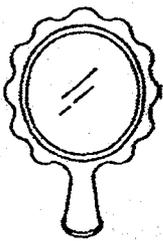

(b) State one property of light.

[1]

38. Jane used an instrument to measure the temperature of water in a container.

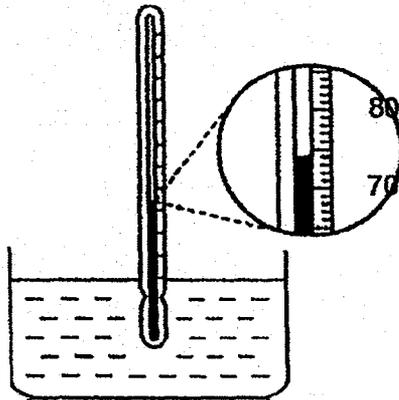

(a) What is the instrument called?

[1]

(b) What is the temperature of the water in the container?

[1]

(c) Why did the liquid in the instrument rise when the instrument is placed in a beaker of hot water?

[1]

39. Kelvin wanted to find out if the length of the shadow would change with the time of the day. On a clear and sunny day, he put a stick in an open field and observed the length of the shadow cast by the stick.

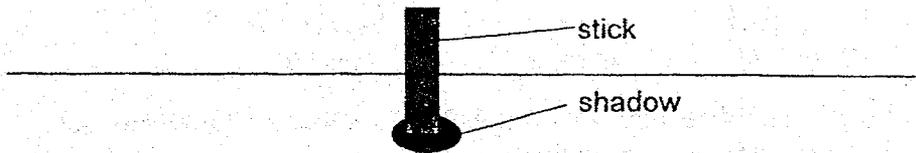

He measured the length of the shadow every hour and recorded the results as shown in the table below.

Time of the day	9 am	10 am	11 am	12 noon	1 pm	2 pm	3pm
Length of shadow (cm)	16	?	7	1	5	11	17

- (a) What could be the likely length of the shadow cast by the stick at 10am? [1]

- (b) What causes a change in the length of the shadow from 9am to 3pm? [1]

- (c) What is the property of the stick that enables Kevin to be able to obtain the results of the experiment? [1]

40. Raj had 3 sheets W, X and Y made of different materials. He cut some shapes out of the materials as shown below.

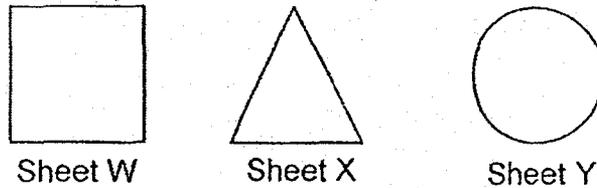

He put the materials together and shone a light at them and observed the shape of the shadow casted on the white screen.

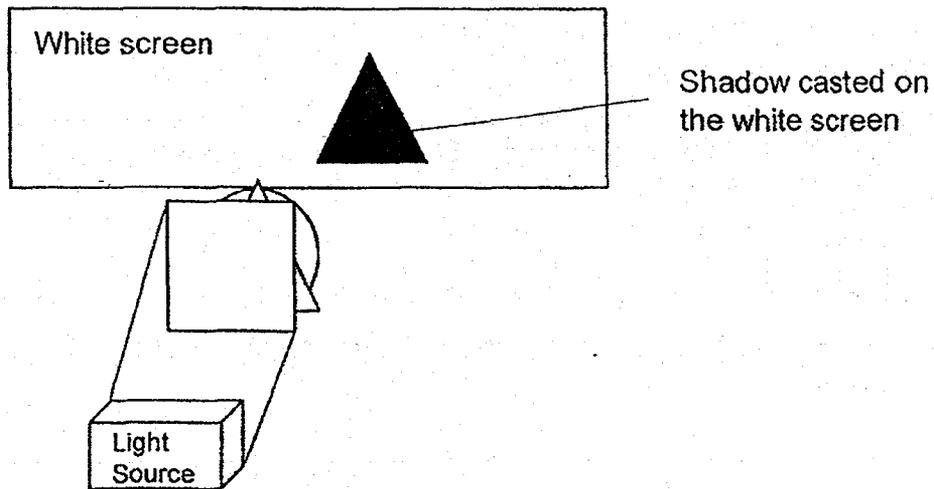

(a) Based on Roy's observation, put a tick (✓) in the correct boxes to show what he could conclude about Sheets W, X and Y. [2]

	Conclusions	True	False	Not possible to tell
(i)	Sheet Y is made of a material that does not allow light to pass through.			
(ii)	Sheet X is made of iron.			
(iii)	Sheet W is made of a material that allows most light to pass through.			
(iv)	Sheets W, X and Y are all made of materials that do not allow light to pass through.			

Question 40 continues on page 12

(b) Write down 2 ways that he could make the shadow on the white screen smaller. [2]

(i) _____

(ii) _____

41 Lewis placed 4 identical sized sheets of different materials, A, B, C and D, as shown in the diagram below to find out how different materials affects the temperature.

He left the 4 materials at the same location under the hot sun for 4 hours before measuring their temperatures. He recorded his results in the table as shown below.

Materials	Temperature (°C)
A	43
B	37
C	58
D	52

(a) Based on the information given, which material should he use to make the following parts of a kettle as shown below? [2]

Parts of a kettle	Material
P	
Q	

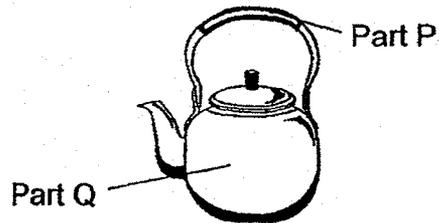

(b) What is the advantage of using the chosen material in (a) to make Part Q of the kettle? Give a reason for your answer. [2]

42. Wes had a glass, Glass A, which was double-layered and contained air between the two layers. There was a tiny opening at the bottom of the glass.

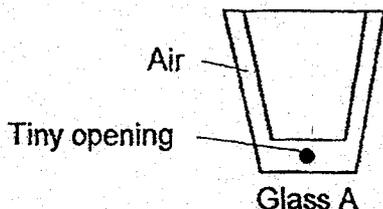

Wes poured some hot water into Glass A and he felt air escaping from the tiny opening.

(a) Why did air escape from the tiny opening in Glass A when hot water was poured into the glass? [2]

Wes took another glass, Glass B, which is made of thick glass. He allowed Glass A to cool completely and then put in ice cubes into both Glass A and Glass B as shown below.

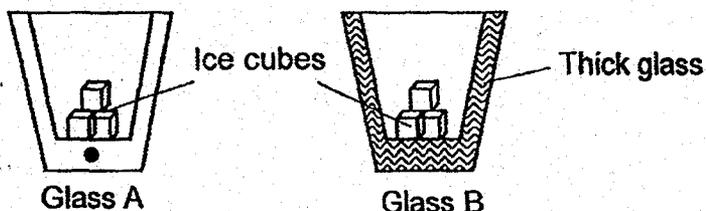

(b) He noticed that the ice in Glass B melted first. Why is this so? [2]

End of Paper

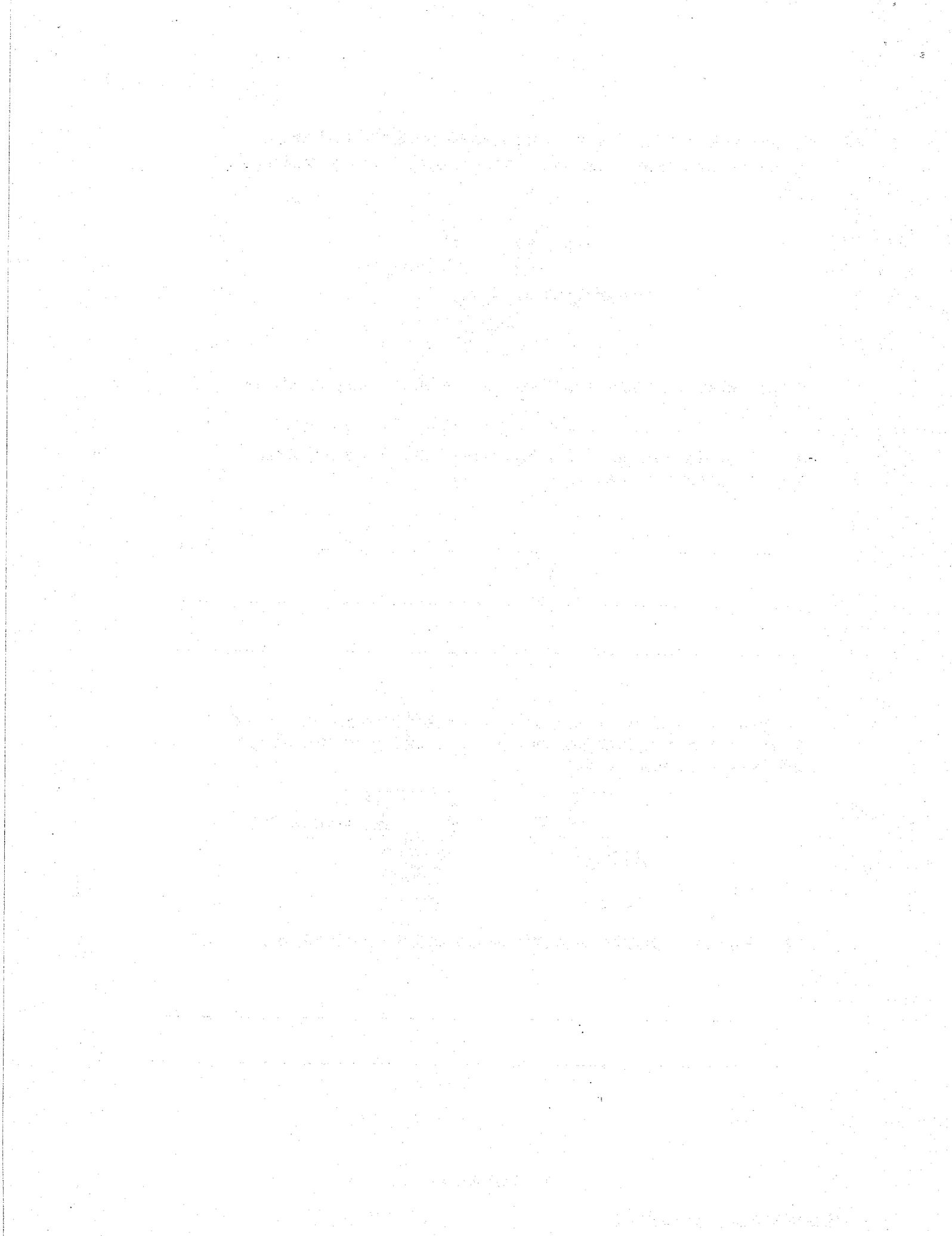

EXAM PAPER 2018 (P4)

SCHOOL : PEI HWA

SUBJECT : SCIENCE

TERM : SA2

Q1	Q2	Q3	Q4	Q5	Q6	Q7	Q8	Q9	Q10
2	1	1	2	1	4	4	4	2	4
Q11	Q12	Q13	Q14	Q15	Q16	Q17	Q18	Q19	Q20
1	3	4	2	2	1	1	2	3	3
Q21	Q22	Q23	Q24	Q25	Q26	Q27	Q28		
2	3	2	3	1	3	2	4		

Q29) A : Rose plant

B : Bird's Nest Fern

C : Bread Mould

D : Cow

Q30) a) This shows that block P floats in water, and block Q sinks in water.

b) The iron nail would most likely beat position B.

Q31) a) i) A

ii) D

b) Part D

Q32) a) Nymph

b) Cockroach

c) The young of the frog does not look like the adult but the young of the grasshopper looks like the adult.

Q33) a) Type of soil – Garden soil

Amount of soil – 2 kg

Type of water – Rice water

Amount of water – 100 ml

b) Joe should place pots A and B at the window.

c) Plants need light to make its own food.

Q34) a) The ball was not fully submerged in the water. Thus, Ada's teacher told her that her result is incorrect.

b) 2, 1, 3, 4

Q35) a) Wood is a non-magnetic material.

b) Magnet B was repelled by magnet A.

Q36) a) The magnetism of an electromagnet increases when the number of batteries increases.

b) i) Coil more rounds around the magnetic material

ii) Use stronger batteries

c) Use the stroke method

Q37) a)



b) Light travels in a straight line.

Q38) a) thermometer

b) 74 .C

c) The liquid gained heat from the hot water and expanded.

Q39) a) 13 cm

b) The changing position of the sun cause a change in the length of the shadow.

c) The stick is opaque.

Q40) a) i) False

ii) Not possible to tell

iii) True

iv) False

b) i) Move the light source further away from the white screen.

ii) Move the screen nearer to the sheets.

Q41) a) P – B

Q – C

b) It is able to heat up, because it is a best conductor of heat.

Q42) a) The cup expanded and takes up more space, causing some air to leave the cup through the tiny opening.

b) Glass is a better conductor of heat than air, so more heat is passed through glass B to melt the ice.

