



HENRY PARK PRIMARY SCHOOL

SECOND SEMESTRAL ASSESSMENT 2019

PRIMARY 4

SCIENCE

SECTION A (56 MARKS)

INSTRUCTIONS TO CANDIDATES

1. Do not turn over this page until you are told to do so.
2. Follow all instructions carefully.
3. Answer all questions.
4. Shade your answers on the Optical Answer Sheet (OAS) provided.

Name: _____ ()

Class: Primary 4 ()

Date: 22 October 2019

Total Time: 1 h 45 min

Section	Marks
A	/ 56
B	/ 44
Total (A+B)	/ 100

Parent's Signature: _____

Booklet A (56 marks)

For each question from 1 to 28, four options are given. One of them is the correct answer.

Make your choice (1, 2, 3 or 4). Shade the correct oval (1, 2, 3 or 4) on the **Optical Answer Sheet**.

1. The diagram shows the human digestive system.

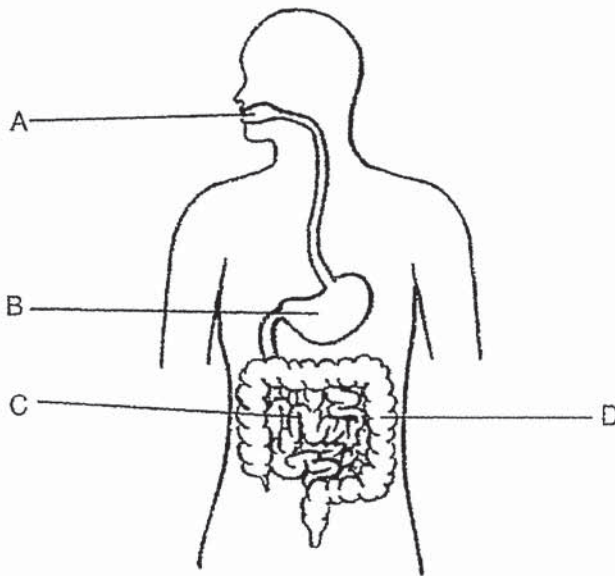

Which of the following is correct?

	Organ not involved in digestion of food	Organ involved in absorption of food
(1)	A	B
(2)	B	A
(3)	C	D
(4)	D	C

2. Which one of the following is not a living thing?

(1)



(2)



(3)

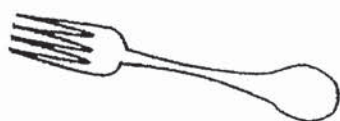

(4)

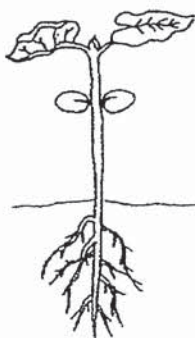

3. Study the diagram below.

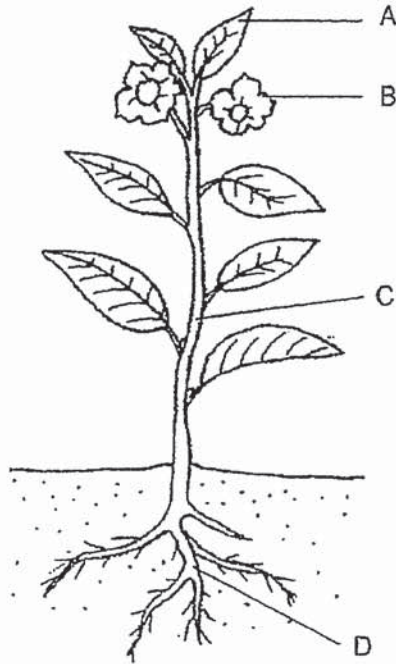

Which one of the following statements about the parts A, B, C and D is **not** correct?

- (1) Part A needs sunlight to make food.
- (2) Part B is found in all plants.
- (3) Part C holds the plant upright to get sunlight.
- (4) Part D absorbs water and minerals from the soil.

4. Sam made the following observations on the life cycle of an animal.

- There are four stages in the life cycle.
- The young does **not** look like the adult.

Which animal was Sam observing?

- (1) frog
- (2) beetle
- (3) chicken
- (4) cockroach

5. The arrows (→) in the diagram show the direction of movement of a substance in plants.

roots → stem → leaves

What is this substance?

- (1) air
- (2) soil
- (3) food
- (4) water

6. Which organ system is shown in the diagram?

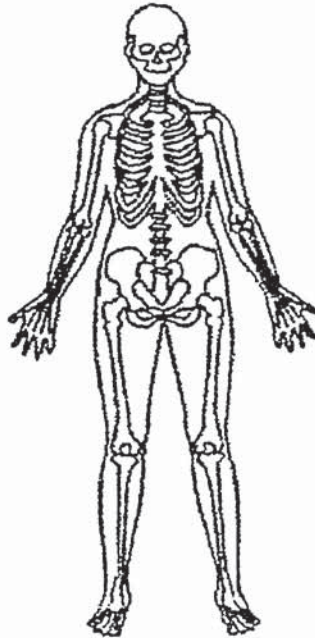

- (1) skeletal system
- (2) muscular system
- (3) circulatory system
- (4) respiratory system

7. Study the diagram below.

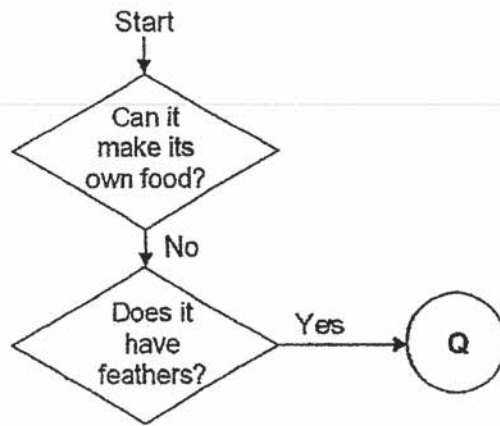

What could Q be?

- (1) bird
- (2) fish
- (3) fern
- (4) reptile

8. The diagram below shows fungi growing on a rotting log.

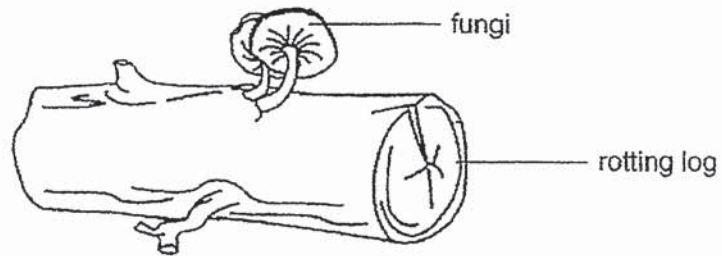

How do the fungi benefit from growing on a rotting log?

- (1) Fungi get more sunlight.
- (2) Fungi feed on the rotting log.
- (3) Fungi obtain more air from the rotting log.
- (4) Fungi provide the log with nutrients.

9. The diagram below shows part of a plant.

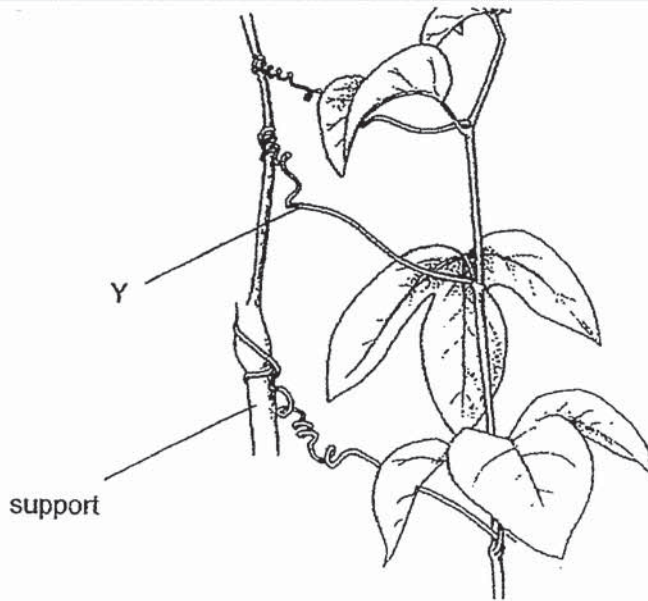

Which one of the following shows the correct function for part Y of the plant?

- (1) It produces fruits.
- (2) It holds the plant firmly into the ground.
- (3) It absorbs water and minerals.
- (4) It helps the plant to be upright.

10. The characteristics of three organisms, X, Y and Z, are given in the table below.

Characteristic	Organism		
	X	Y	Z
Needs light to make food	Yes	No	No
Depends on other organisms for food	No	Yes	Yes
Reproduces by spores	Yes	Yes	No

From the table above, which of the following could organisms X, Y and Z be?

	Bird	Fern	Mould
(1)	X	Y	Z
(2)	Y	Z	X
(3)	Z	X	Y
(4)	Z	Y	X

11. The set-up below shows light shining on a wooden ball.

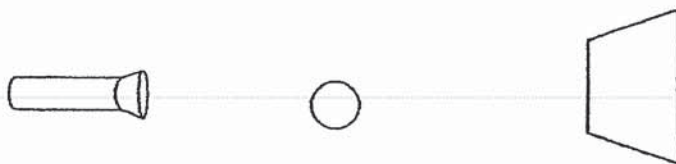

Which one of the following would likely be seen on the screen?



(1)



(2)



(3)

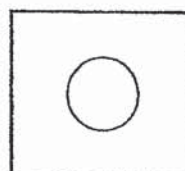

(4)

12. Which one of the following is the best conductor of heat?

- (1) A paper cup
- (2) A metal cup
- (3) A plastic cup
- (4) A wooden cup

()

13. In the diagram, what is the volume of liquid Y?

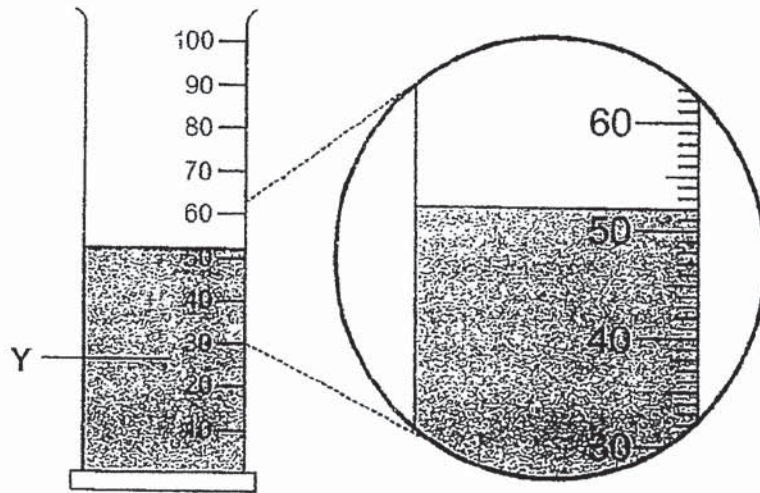

- (1) 50 ml
- (2) 52 ml
- (3) 54 ml
- (4) 68 ml

()

14. The diagram shows a magnet brought near a steel block.



What will happen to the steel block?

- (1) It will move up.
- (2) It will not move.
- (3) It will move to the left.
- (4) It will move to the right.

()

15. Ronald places a metal spoon in a cup of hot tea.

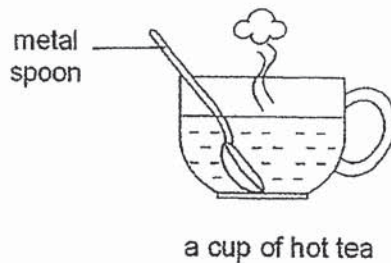

The spoon becomes hotter after a while.

Which one of the following explains this?

- (1) The cup loses heat to the hot tea.
- (2) The hot tea gains heat from the spoon.
- (3) The spoon gains heat from the hot tea.
- (4) The spoon loses heat to the surrounding air.

()

16. Six items are classified into two groups, A and B, as shown below.

Group A	Group B
magnet	water
pencil	paint
ice cube	oxygen

Which one of the following is a suitable heading for groups A and B?

	A	B
(1)	Solid	Liquid
(2)	Solid	Gas
(3)	Has fixed shape	Has no fixed shape
(4)	Has fixed volume	Has no fixed volume

()

17. Richard fills a balloon with air.

He then twists and squeezes it until it is shaped like an animal as shown below.

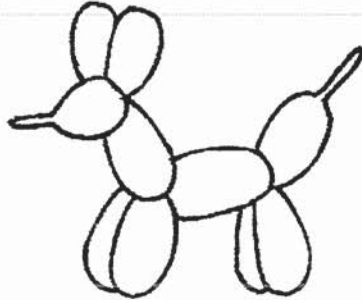

Which property of air allows Richard to change the shape of the balloon?

- (1) Air has mass.
- (2) Air is a matter.
- (3) Air has no fixed volume.
- (4) Air does not occupy space.

()

18. Leonard measured the mass of a sealed packet of sweets using an electronic balance as shown below.

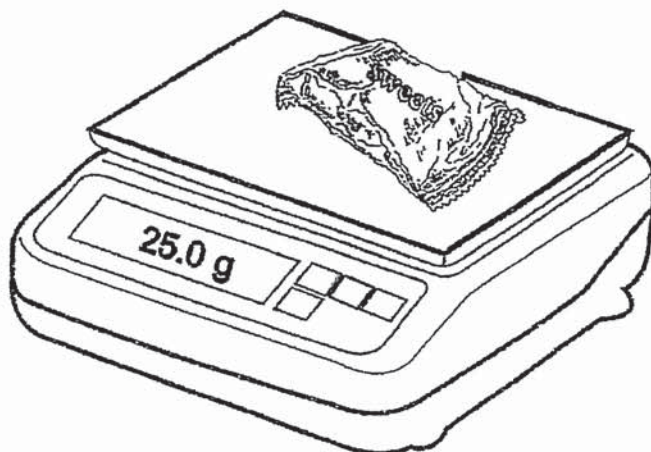

He recorded the results as shown below.

Mass of sealed packet of sweets = 25 g
Mass of one sweet = 1 g

He expected to find 25 sweets in the sealed packet. However, he found that there were only 22 sweets in the sealed packet.

Which of the following is / are likely to be the reason(s) for not having 25 sweets in the packet?

- A The wrapper has mass.
- B Air inside the wrapper has volume.
- C The wrapper has a definite shape.

- (1) A only
- (2) A and B only
- (3) A and C only
- (4) B and C only

()

19. Mr. Wee wanted to put a steel ball through a steel ring. The steel ball is just too big to fit into the hole of the steel ring.

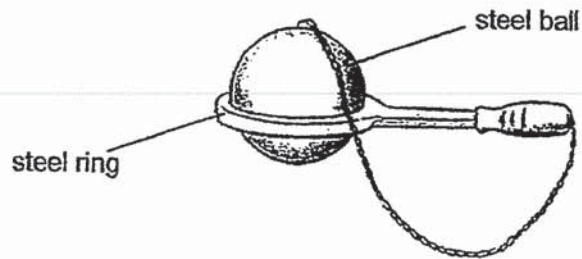

How can Mr Wee put the ball through the ring?

- (1) Cool the ball and then place it through the ring.
- (2) Cool the ring and the ball to the same temperature and then push the ball through the ring.
- (3) Cool the ring and then push the ball through the ring.
- (4) Heat the ball and then push the ball through the ring

()

20. Samy placed two empty containers, one made of metal and the other made of plastic, both at room temperature, on a table. He poured 500 ml of boiling water into both containers.

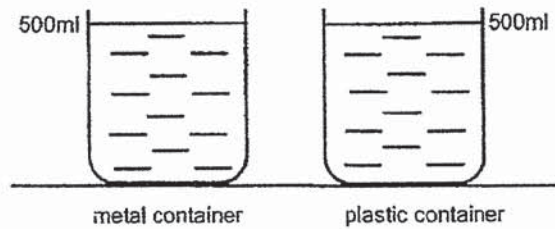

The temperature of water in both containers were recorded every 5 minutes for some time. Which one of the following shows the correct graph for his results?

(1) temperature (°C)

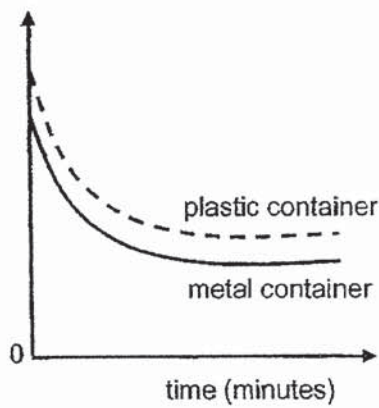

(2) temperature (°C)

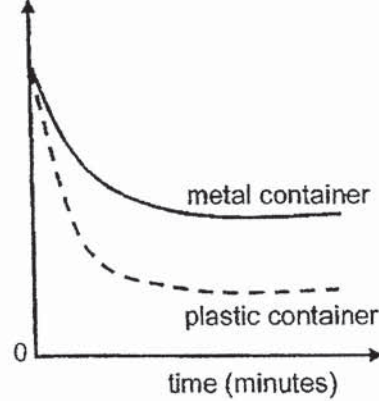

(3) temperature (°C)

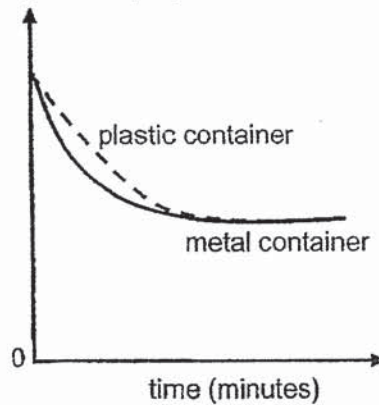

(4) temperature (°C)

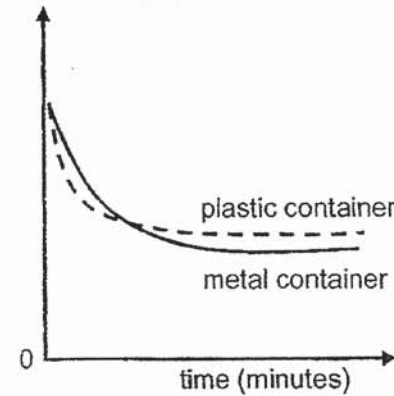

()

21. Four thumbtacks, 1, 2, 3 and 4, were attached to different parts of a copper rod with wax.

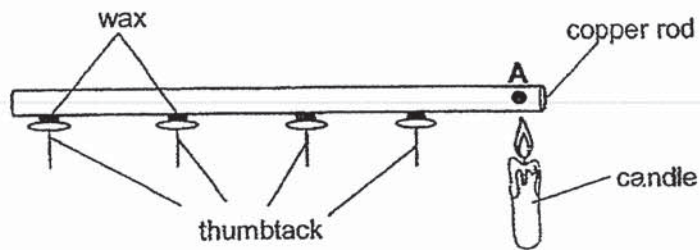

A candle flame was used to heat up spot A on the copper rod as shown in the diagram above. The four thumbtacks dropped from the metal rod in the following order: 1, 4, 3 and 2.

Which one of the following sets of measurement could be the distance of each thumbtack from spot A?

Thumbtacks				
	1	2	3	4
(1)	12 cm	8 cm	3 cm	18 cm
(2)	3 cm	18 cm	12 cm	8 cm
(3)	12 cm	18 cm	3 cm	8 cm
(4)	3 cm	12 cm	18 cm	8 cm

()

22. Cloths of different temperatures are placed around the flask of each set-up. A glass tubing is inserted from the flask into a basin of water as shown below.

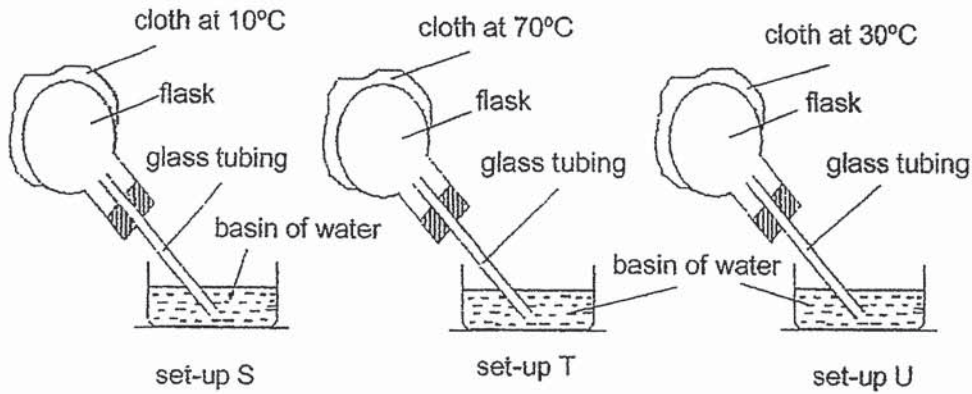

The water in each basin is at the room temperature of 30°C.

In which of the following set-ups will there be no bubbles observed in the basin of water?

- (1) S and U only
- (2) T and U only
- (3) T and S only
- (4) S, T and U

()

23. Sarah observed some objects in a jar and made the following observations about the jar and the objects.

Sarah's observations:

1. There are four objects in the jar.
2. The colour of each object cannot be seen clearly.

Based on her observations, Sarah made the following statements.

Statements:

- A: The material of the jar does not allow any light to pass through it.
B: The objects in the jar do not reflect any light into the eyes.
C: The material of the jar allows most light to pass through it.
D: The material of the jar allows some light to pass through it.

Which statement is correct?

- (1) A
- (2) B
- (3) C
- (4) D

()

24. Some objects give off light and some reflect light.

Which of the following classification is correct?

	Gives off light	Reflects light
(1)	moon	book
(2)	coin	star
(3)	lamp	sun
(4)	candle flame	moon

()

25. Jonathan set up four identical metal tanks in a room. Each tank contains the same amount of water. The water is at the same temperature as the room.

Two of the tanks are wrapped with rubber. A hot metal block has been placed in each of the tanks, in the positions shown in the diagrams below.

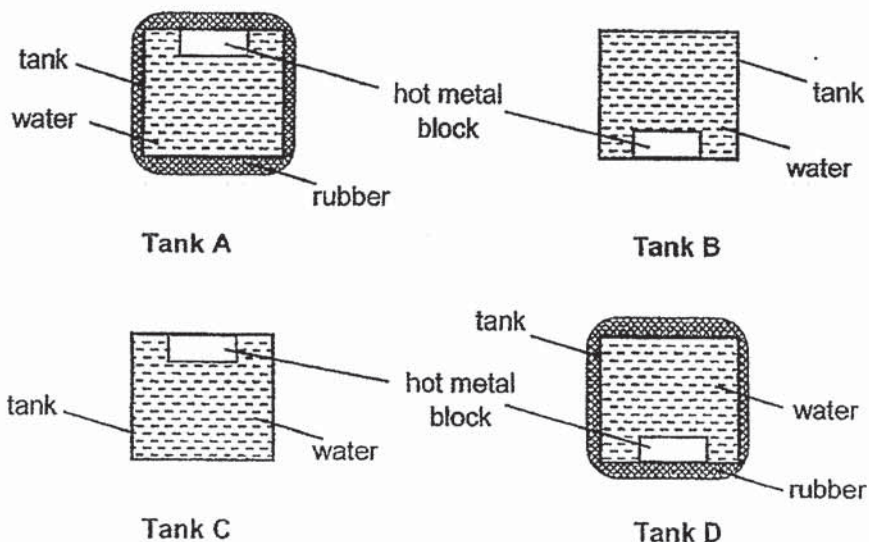

Based on the information given above, which one of the following shows correctly the set-ups for the different aims of the experiment?

Aim of experiment	
To find out if the position of the metal block affects how quickly temperature of water in the tank increases.	To find out if the tank wrapped with rubber keeps the water hot for a longer time.
(1) A and B	A and C
(2) C and D	A and B
(3) A and D	C and D
(4) B and C	B and D

()

26. John conducted an experiment as shown in the diagram below.

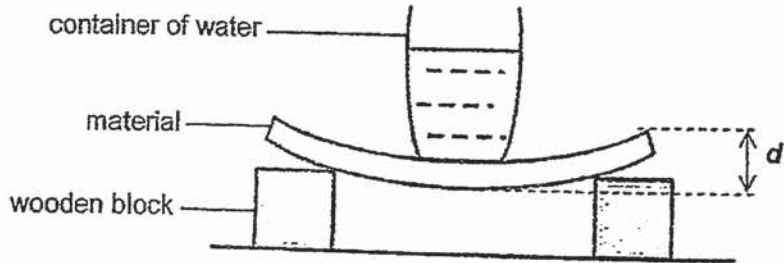

For each material (A, B, C and D), John placed a container of 50 ml of water and measured distance, d , which is the distance between the highest and lowest points of the material.

He recorded the results in the table below.

Material	d (cm)
A	10
B	5
C	19
D	14

The diagram below shows a food tray used in a fast food outlet.

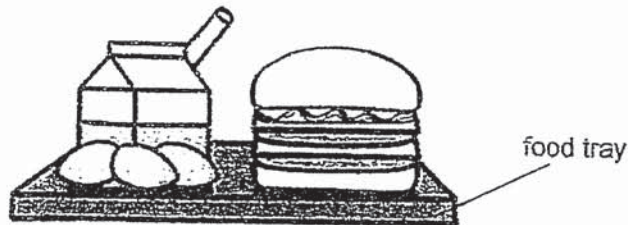

Which material is most suitable to make the food tray?

- (1) A
- (2) B
- (3) C
- (4) D

()

27. Keegan hung three strong bar magnets in two different set-ups, A and B, as shown below.

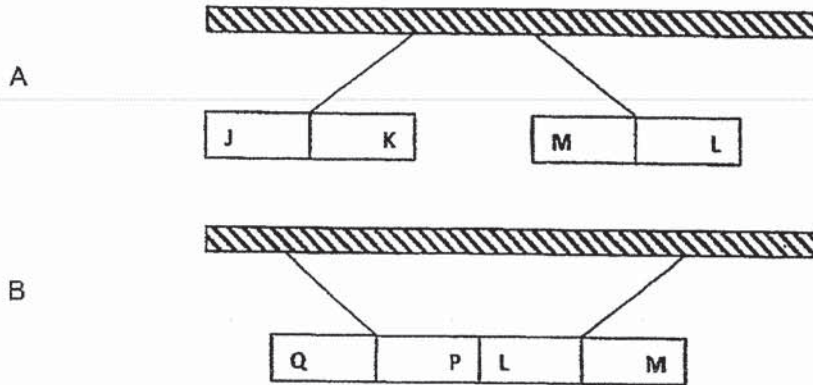

Based on set-ups A and B, which of the following arrangements is possible?

(1)

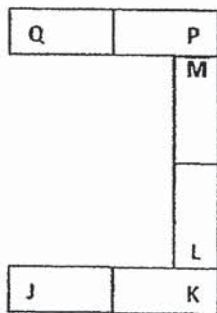

(2)

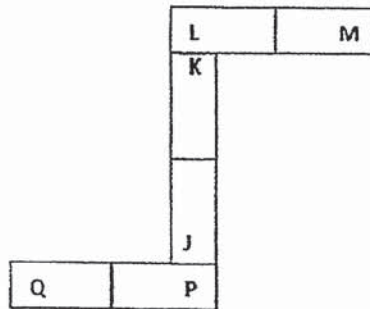

(3)

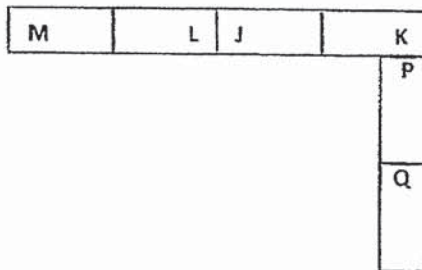

(4)

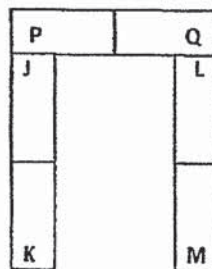

28. Annette hung four magnets, A, B, C and D, above a tray of identical steel pins. Her observation is shown below.

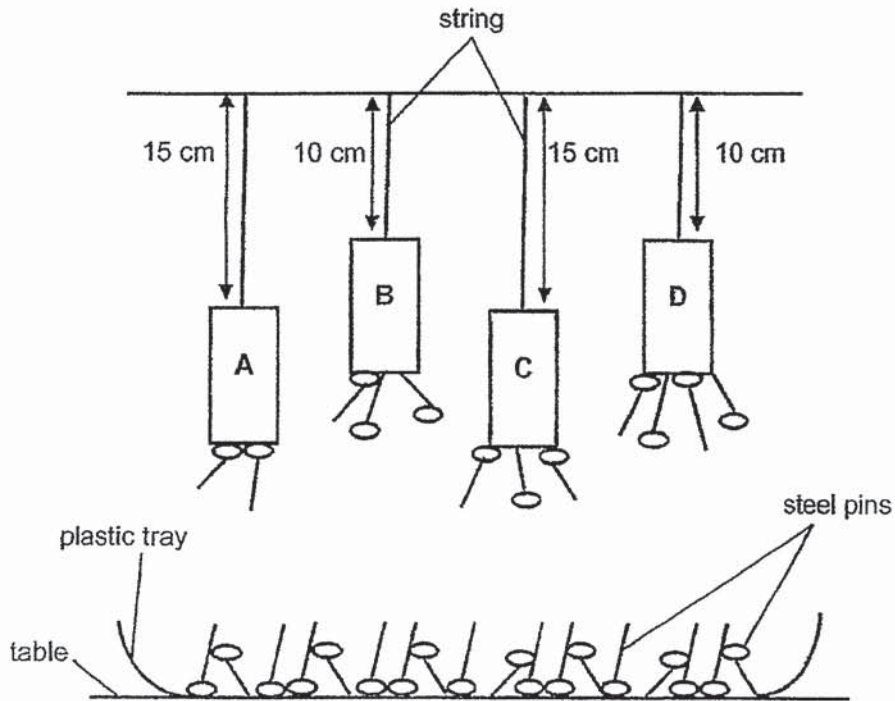

Arrange the strengths of the magnets from the strongest to the weakest based on her observations.

	strongest	→	weakest
(1)	A		D
(2)	A		D
(3)	D		A
(4)	D		A

()

End of Booklet A



HENRY PARK PRIMARY SCHOOL
SECOND SEMESTRAL ASSESSMENT 2019

PRIMARY 4

SCIENCE

SECTION B (44 MARKS)

INSTRUCTIONS TO CANDIDATES

1. Do not turn over this page until you are told to do so.
2. Follow all instructions carefully.
3. Answer all questions.

Name: _____ ()

Class: Primary 4 ()

Date: 2019

Total Time: 1 h 45 min

Marks for Sections B: _____

Booklet B (44 marks)

For questions 29 to 41, write your answers in the space provided.

The number of marks available is shown in brackets [] at the end of each question or part question.

29. The diagram shows the amount of digested food in the blood entering and leaving the small intestine a few hours after a meal.

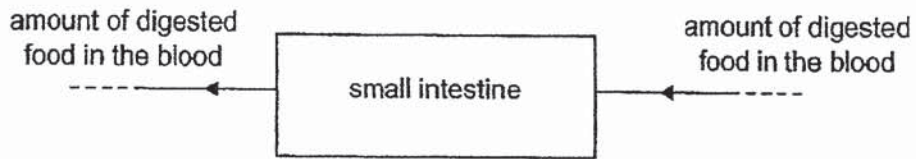

- a) The amount of digested food in the blood leaving the small intestine is higher than the amount of digested food in the blood entering the small intestine. [1]

Give a reason for this observation.

The diagram shows the amount of undigested food entering and leaving the gullet a few minutes after chewing some food.

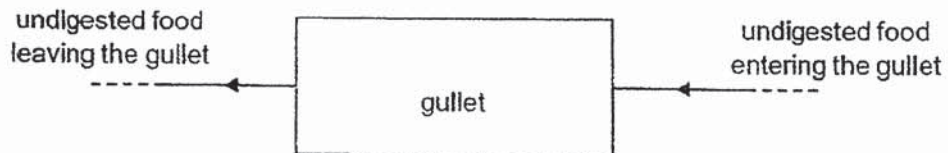

- b) The amount of undigested food entering and leaving the gullet remains the same. [2]

Explain why.

30. Study the diagram below.

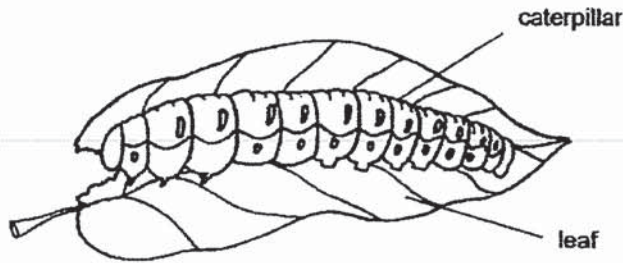

a) The caterpillar needs _____, food and water to stay alive. [1]

b) The caterpillar eats leaves and becomes bigger after some time.
This shows that it can _____ . [1]

31. The diagram below shows the young and adult of some organisms. Draw lines to match the young with the correct adult. [3]



32. Gina used 3 similar plants, E, F and G, for an experiment as shown in the diagram below. She removed some leaves from plant F and all the leaves from plant G. The three set-ups were placed near an open window.

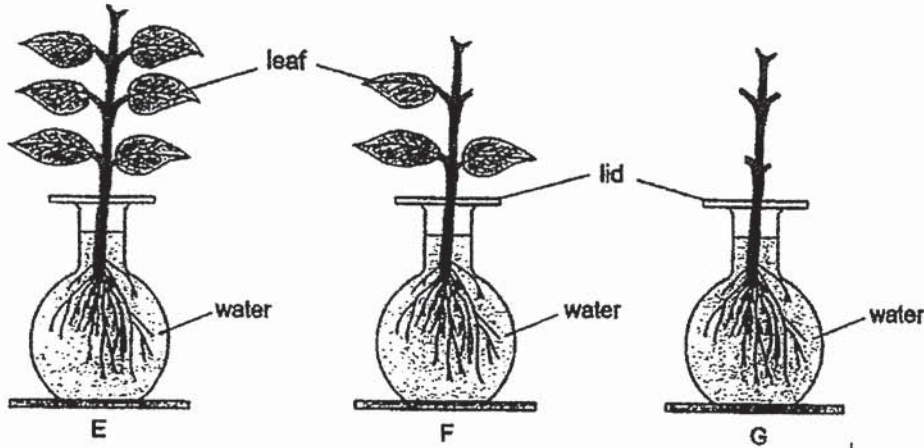

After 3 days, Gina measured the amount of water left in each set-up. The results are shown in the table below.

Plant	Number of leaves	Amount of water in set-up (ml)	
		Start of experiment	After three days
E	6	300	210
F	3	300	245
G	0	300	293

- a) How does the number of leaves affect the amount of water taken in by each plant? [1]
-
-
- b) State one **other** variable Gina must keep the same for each set-up to ensure the experiment is fair. [1]
-
- c) Predict the amount of water left in the set-up after three days if plant F had 5 leaves. [1]
-

33. The diagrams below represent the life cycles of a mosquito and a grasshopper.

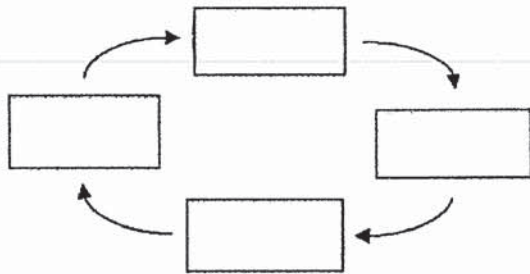

Life cycle of a mosquito

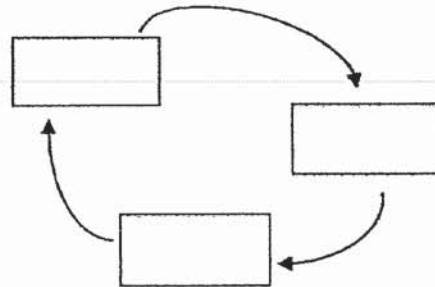

Life cycle of a grasshopper

a) Fill in the boxes above with the following words. (You may repeat some of the words) [2]

adult	egg	pupa	larva	nymph
-------	-----	------	-------	-------

b) State one difference between the mosquito and the grasshopper in terms of where their eggs are laid. [1]

Mosquitoes are pests that spread diseases such as dengue fever.

c) Explain how removing still water helps to prevent these mosquitoes from reproducing. [1]

34. Desmond can see his school bag in the presence of light as shown in the diagram below.

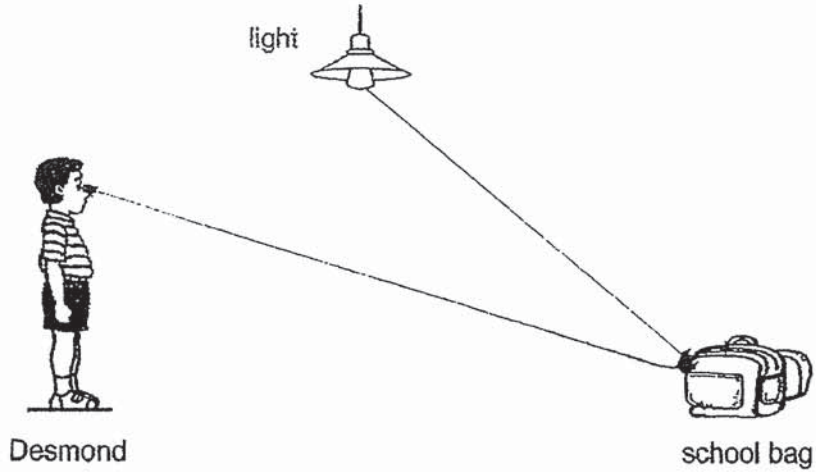

- a) Using arrows, **draw** the path of light in the diagram above to show how Desmond is able to see his school bag. [1]

Desmond had 4 shapes each made of a different material as shown below.

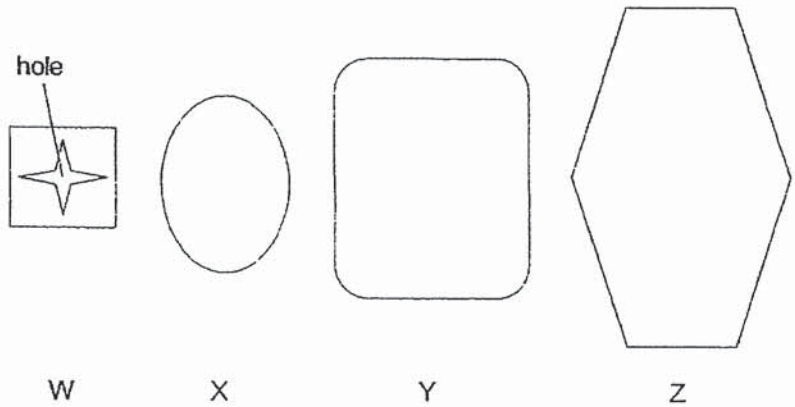

In a dark room, he placed all the cut-outs in front of a torch, as shown in the diagram below.

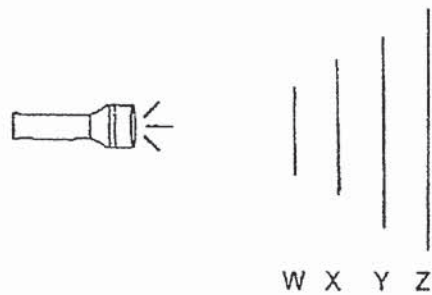

Question 34 continued

Desmond switched on the torch and recorded his observation of the shadow formed on material Y as shown below. There was nothing seen on material Z.



observation of the shadow
formed on material Y

- b) Based on Desmond's observation, name the materials (W, X, Y and Z) that do not allow any light to pass through. [1]

Desmond lighted a candle in a paper lantern in diagram 1. He raised the paper lantern as shown in diagram 2.

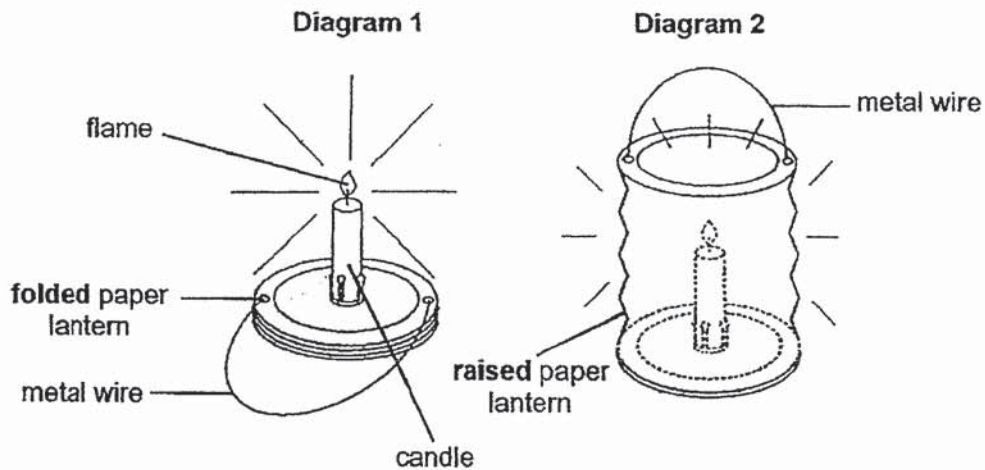

- c) When Desmond raised the paper lantern, the flame looked **less** bright.
Explain why. [1]

35. Ahmad fixed one end of a deflated balloon tightly to a straw using a rubber band. He taped the end of the balloon to the bottom of a basin which was filled with water. After he had marked the water level, he blew air into the straw in the diagram below.

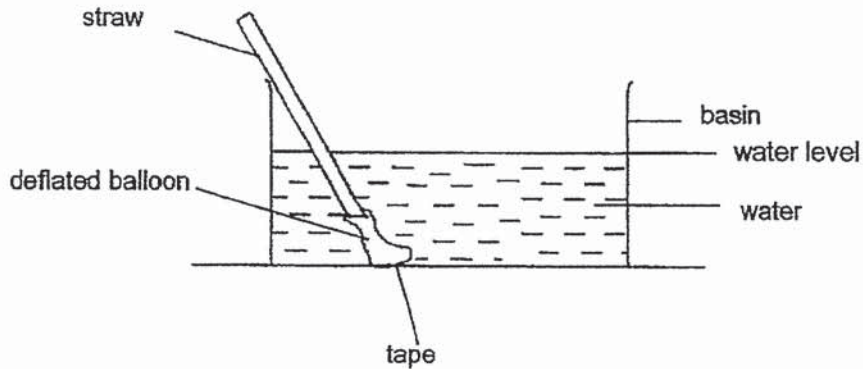

- a) State one observation that Ahmad would make about the water level in the basin when air is blown into the straw. Explain your answer. [2]

- b) Ahmad placed a balloon into a plastic bottle as shown below.

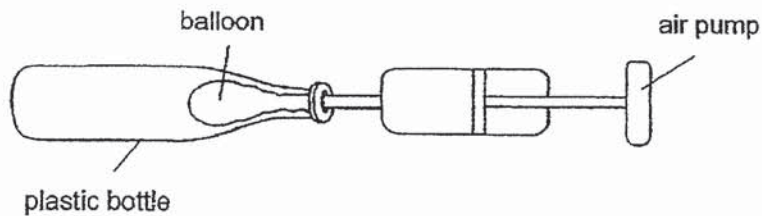

- i) He tried to fill the balloon with air using an air pump but could not do it. Explain why this is so. [1]

- ii) Without removing the balloon from the mouth of the bottle, state one change that Ahmad could make to the bottle so that the balloon would be able to inflate when air was pumped into it. Give a reason for your answer. [1]

36 a) State what is temperature.

[1]

Two glass cups were found stuck to one another in Mrs Wong's cupboard. She added some ice cubes to cup B as shown in the diagram below.

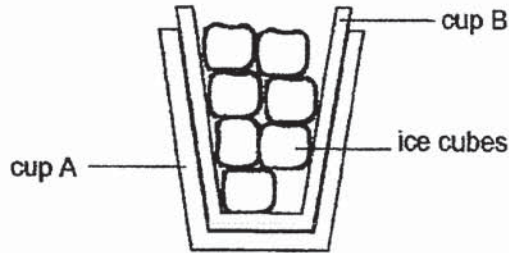

b) After a while, she found it easier to remove the two cups from each other. Explain why.

[1]

A railway track has gaps along its metal rails as shown in the diagram below.

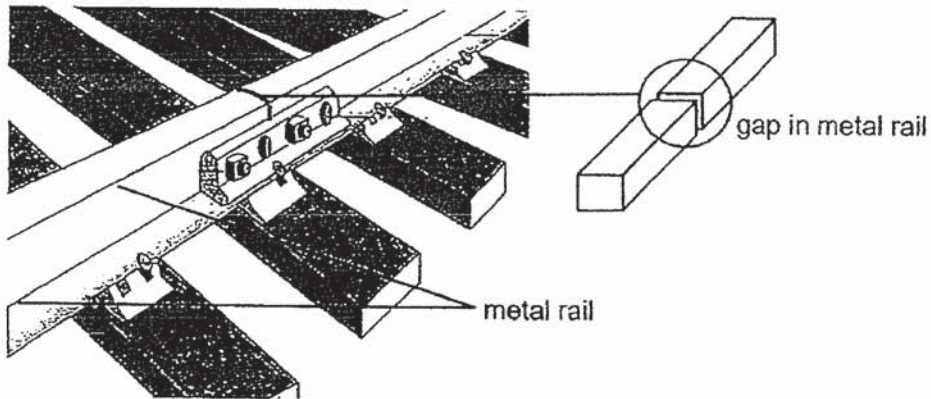

c) What would happen to the railway track on a very hot day if there were no gaps? Explain your answer.

[2]

37. Siti carried out an experiment as shown in the diagrams below.

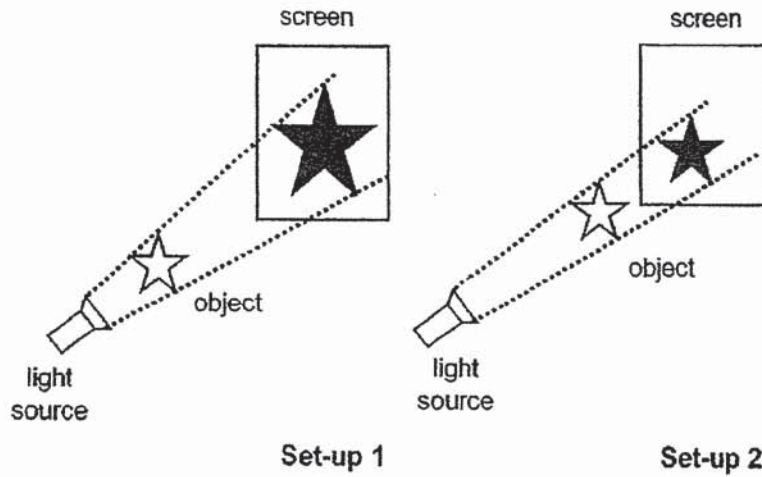

The experimental set-ups 1 and 2 show the same object casting the shadows on the screens.

The distance between the light source and the screen is fixed.

a) Explain the **difference in the sizes of the shadows** cast on both screens. [2]

Siti carried out another experiment to find out the change in the length of shadows. In this experiment, the position of the object did not change. Siti measured the length of the shadows formed.

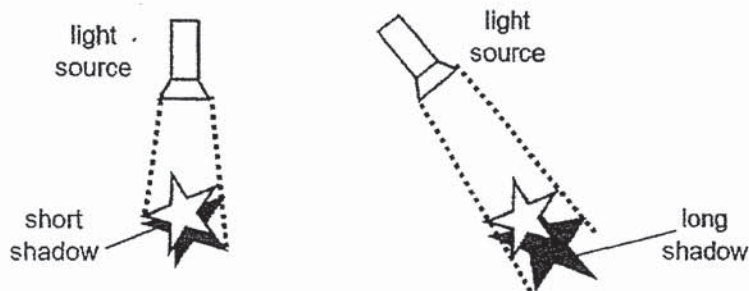

b) Name the variable changed in the above experiment. [1]

38. Gopi has a tropical fish tank. Algae grow on the inner sides of his tank as shown in the diagram below. Algae are tiny green organisms that use sunlight to make their own food.

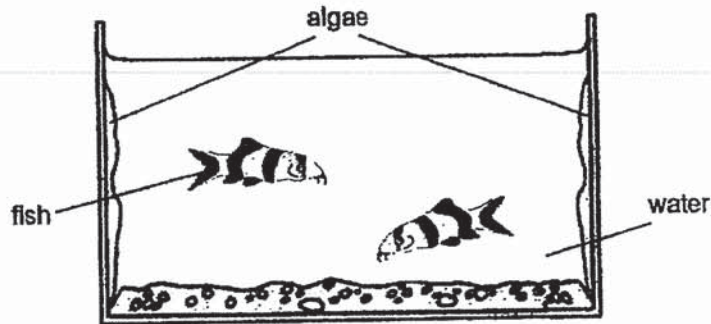

Gopi wants to keep his fish tank clean of algae. He uses two magnets for this. He puts magnet B on the outside and magnet A on the inside as shown below.

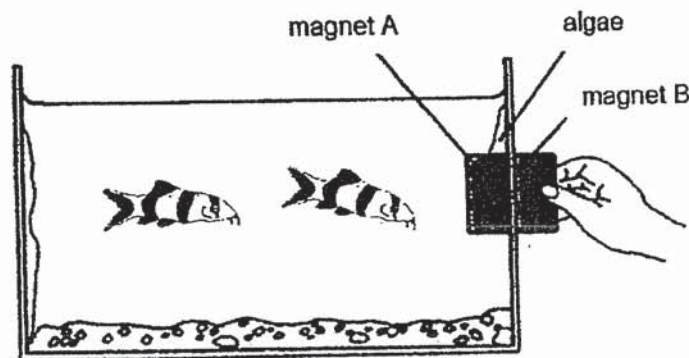

As Gopi moves magnet B, magnet A also moves in the same direction.

- a) Based on the information given, explain how this method helps to keep the tank clean of algae. [2]

Gopi's fish tank was placed near an open window. His mother suggested that he moves the fish tank to a shady spot.

- b) Based on the information given, explain how moving the fish tank to a shady spot will prevent the growth of algae in the fish tank. [2]

39. Mrs Lee put three ice cubes on a metal bowl. She placed the bowl in a room with a temperature of about 30°C. After a short while, the ice cubes started to melt as shown below.

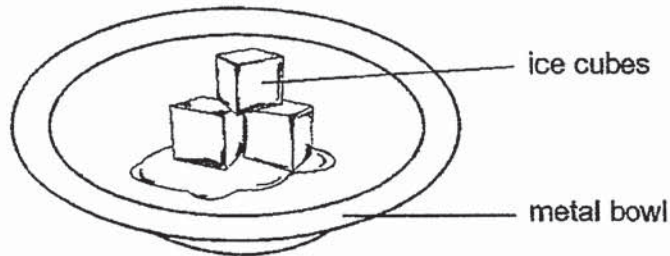

- (a) Based on the information given, complete the table below.

[1]

The ice cubes	Source of heat
<p><input type="checkbox"/> gained heat</p> <p><input type="checkbox"/> lost heat</p> <p>Tick (✓) the correct box.</p>	<p>Name the source of heat that made the ice cubes melt.</p> <p>_____</p>

Question 39 continued

The diagram below shows the water heater system in Mrs Lee's home.

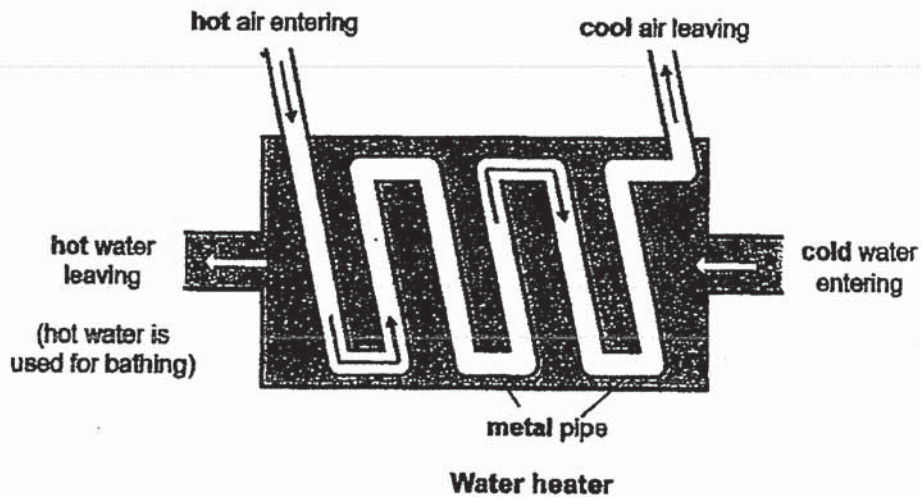

- (b) Explain why a metal pipe is more suitable for the water heater than a plastic pipe. [1]

The diagrams below show two similar metal pipes of different thickness.

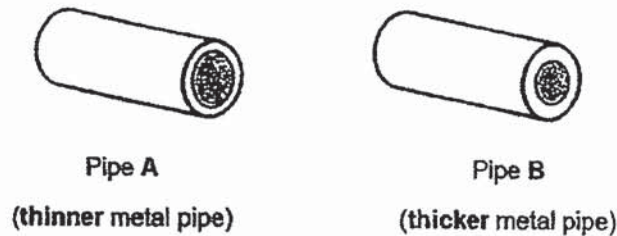

Mrs Lee wants to make improvements to the water heater system so that the water becomes hotter faster.

- (c) Explain why using metal pipe A will make the water hotter in a shorter time. [1]

- (d) Suggest **another** improvement she can make to the metal pipe in the water heater to obtain hotter water. [1]

40. Malek used the set-up shown below to test the strength of four planks made of different materials, A, B, C and D. He placed identical bricks, one at a time, on each plank until the plank broke.

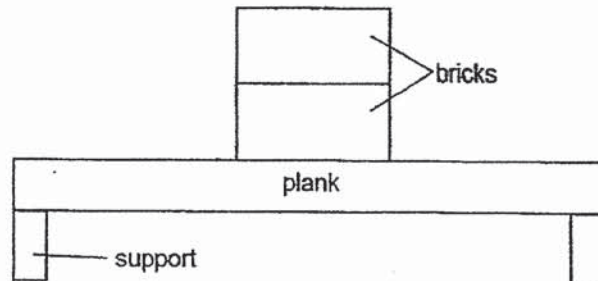

His results are shown in the table below.

Material of plank	Maximum number of bricks placed on the plank before it broke
A	15
B	21
C	9
D	13

The diagram below shows a bookshelf.

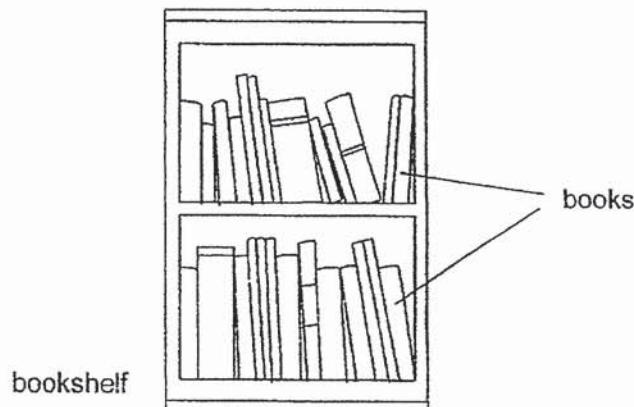

- a) Based on the results given, which material (A, B, C or D) would be most suitable to make the bookshelf? Explain your answer. [2]

Question 40 continued

Alex placed two different blocks, M and N, into a beaker of water as shown below.

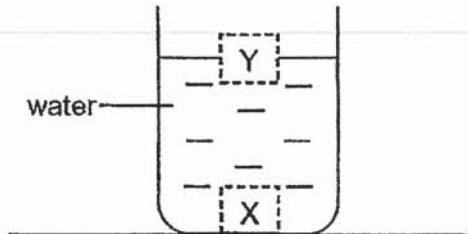

b) Block M was found at position Y, while block N was found at position X.

Fill in the blanks using the correct words in the box.

[2]

floats	sinks	contracts	expands
--------	-------	-----------	---------

This shows that block M _____ in water, and block N _____ in water.

41. Tick (✓) if each of the following has a definite shape and / or a definite volume.

[3]

	<u>Has definite shape</u>	<u>Has definite volume</u>
a) milk	()	()
b) ruler	()	()
c) air	()	()

End of Booklet B

Setters: Mrs Priscilla Heng, Mr Yuan Kee King and Mdm Nadia Abu Bakar

CORRECTIONS SHEET FOR P4 SCIENCE 2019 SA2

Q1	4	Q8	2	Q15	3	Q22	1
Q2	3	Q9	4	Q16	3	Q23	4
Q3	2	Q10	3	Q17	3	Q24	4
Q4	2	Q11	3	Q18	1	Q25	4
Q5	4	Q12	2	Q19	1	Q26	2
Q6	1	Q13	2	Q20	3	Q27	2
Q7	1	Q14	3	Q21	2	Q28	4

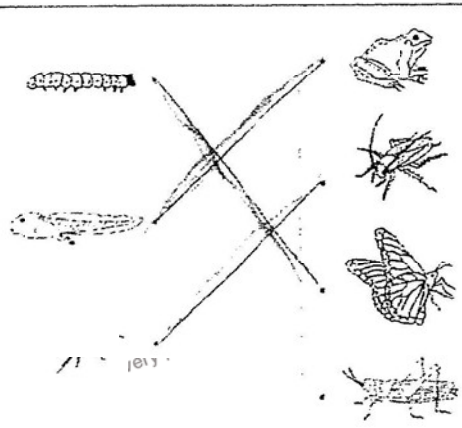
29a	The digested food in the small intestine is absorbed into the blood	
b	The gullet does not produce any digestive juices to breakdown the undigested food passing through	
30	(a) air (b) grow	
31		
32a	As the number of leaves increase, the plant takes in more water.	
32 b	Temperature of water	

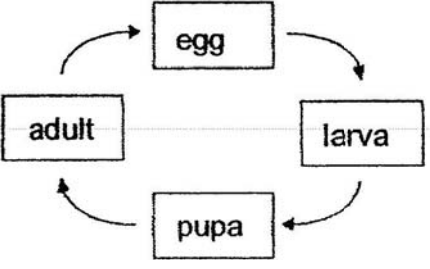
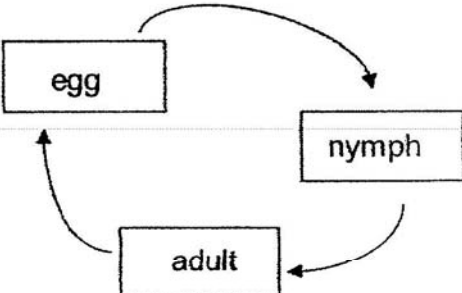
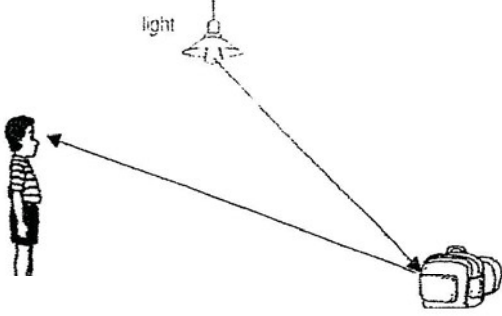
32 c	211ml	
33a	 <pre> graph TD egg --> larva larva --> pupa pupa --> adult adult --> egg </pre>	 <pre> graph TD egg --> nymph nymph --> adult adult --> egg </pre>
33b	Mosquitoes lay their eggs in the water but grasshoppers lay their eggs on land.	
33c	Mosquitoes lay eggs in still water. By removing still water, mosquitoes cannot reproduce/breed.	
34a.		
34b.	W and Y	
34c.	The <u>paper lantern</u> blocks some light from passing through.	
35a.	Water level will increase. Air blown into the balloon will occupy the space in the balloon. The inflated balloon will occupy more space in the water.	

35b. (i)	There is already air taking up space in the bottle	
35b. (ii)	Make a hole in the plastic bottle so that air in the bottle escapes.	
36a.	Temperature is the unit of measurement of the amount of heat energy an object has.	
36b.	Cup B lost heat to the ice cubes and contracted.	
36c.	It will buckle as the metal rail gains heat from the Sun or surrounding and expands.	
37a	Object in set-up 1 is closer to the light source so the shadow cast is bigger.	
37b	The position or angle of the light source.	
38a	The magnets are attracted to each other as their unlike poles are facing each other. As magnet B moves, magnet A moves along in the same direction and at the same rate, rapping off the algae out of the tank.	
38b.	Algae cannot make food as it will not receive any sunlight.	
39a.	Ice cubes gain heat from the surrounding air or metal bowl.	

39b.	Metal pipe conducts heat from the hot air to the cold water faster.	
39c.	Pipe A is thinner so heat is conducted to the water faster.	
39d.	Make the metal pipe longer.	
40a.	Material B. It needed the most number of bricks to be placed on it before it broke. This shows that it is the strongest material. So it will not break easily when holding the weight of a large number of books.	
40b.	Floats, sinks	
40c.	(a) Tick (<input checked="" type="checkbox"/>) definite volume only (b) Tick (<input type="checkbox"/>) both (c) Tick (<input type="checkbox"/>) neither	

1011

4

3710