



MARIS STELLA HIGH SCHOOL (PRIMARY)

SA1 EXAMINATION

SCIENCE

16 MAY 2019

BOOKLET A

NAME: \_\_\_\_\_ (       )

CLASS: Primary 4 (       )

24 questions

48 marks

Total Time for Booklets A & B:     1 h 30 min

DO NOT OPEN THIS BOOKLET UNTIL YOU ARE TOLD TO DO SO.

FOLLOW ALL INSTRUCTIONS CAREFULLY.



For each question from 1 to 24, four options are given. One of them is the correct answer. Make your choice (1, 2, 3 or 4). Shade the correct oval (1, 2, 3 or 4) on the Optical Answer Sheet (OAS). **(48 marks)**

- 1 The diagram below shows the growth of a flowering plant with two missing stages, X and Y.

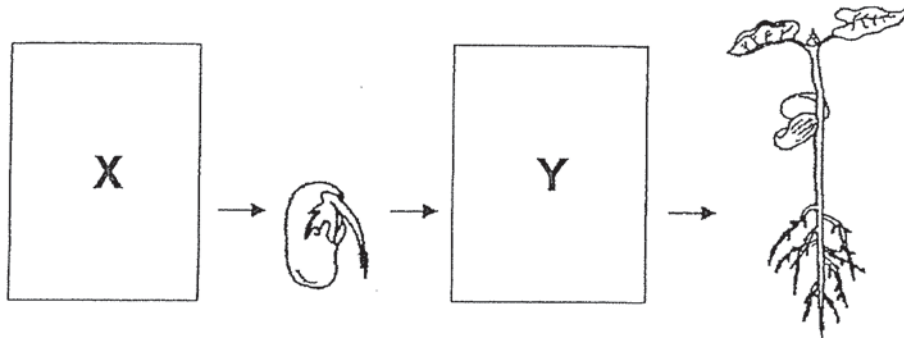

Which one of the following shows the correct stages for X and Y?

	X	Y
(1)		
(2)		
(3)		
(4)		

2 Which of the following about the beetle is correct?

- (1) It has a pupal stage.
- (2) It gives birth to young.
- (3) Its young looks like the adult.
- (4) It has 3 stages in its life cycle.

3 Study the chart below.

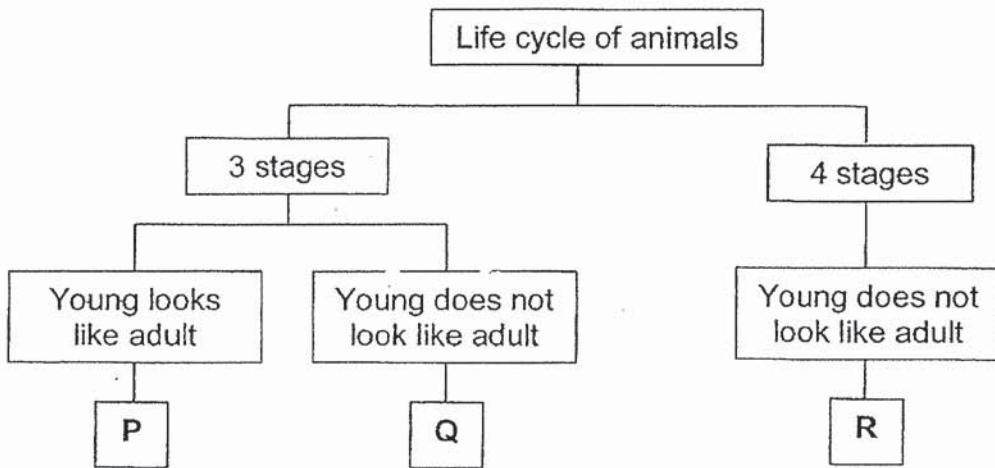

Which one of the following represents P, Q and R?

	P	Q	R
(1)	mosquito	frog	cockroach
(2)	cockroach	frog	mosquito
(3)	mosquito	cockroach	frog
(4)	cockroach	mosquito	frog

4 Below are two statements about P and Q.

- Both P and Q reproduce by spores.
- P does not make its own food but Q makes its own food.

What can P and Q be?

	P	Q
(1)	fern	mushroom
(2)	rose plant	mushroom
(3)	fern	rose plant
(4)	mushroom	fern

5 Which one of the following correctly matches the human system to its function?

	System	Function
(1)	circulatory system	carries materials around the body
(2)	muscular system	gives the body its shape
(3)	respiratory system	helps different parts of the body to move
(4)	skeletal system	breaks down food

6 The graph below shows the changes in the number of animal X over three months.

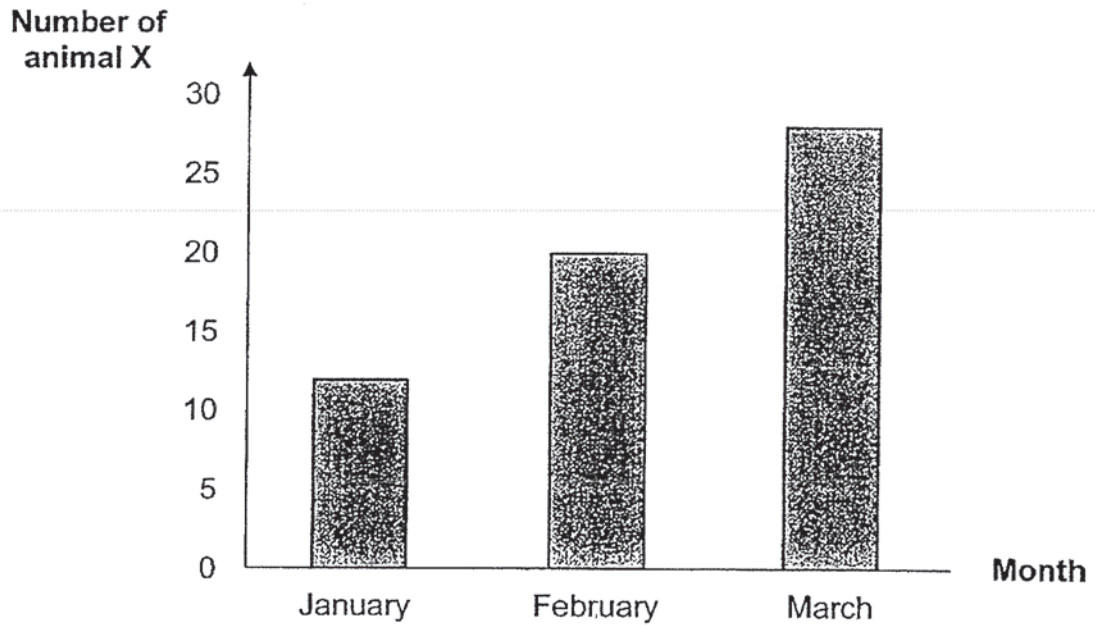

What happened to animal X to cause the change observed from January to March?

- (1) They died.
- (2) They reproduced.
- (3) They increased in size.
- (4) They responded to changes.

7 The diagram below shows different parts of a human system.

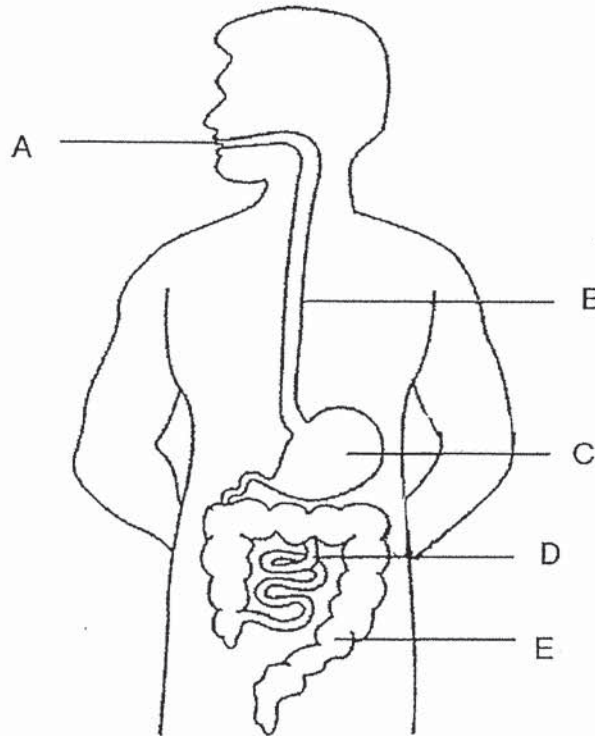

Which parts do digestion of food take place?

- (1) A, B and C only
- (2) A, C and D only
- (3) C, D and E only
- (4) A, B, C, D and E

8 Which of the following is **not** a matter?

- (1) air
- (2) light
- (3) sand
- (4) water

- 9 The table below shows the properties of four materials, A, B, C and D.  
A tick (✓) indicates that the material has that property.

Properties	Materials			
	A	B	C	D
Strong	✓	✓	✓	
Waterproof		✓	✓	✓
Ability to float in water	✓			✓
Bends easily without breaking	✓	✓		

Which material is most suitable for making part X of an umbrella?



- (1) Material A
- (2) Material B
- (3) Material C
- (4) Material D



10 Study the table below.

Substance	Has a definite shape	Has a definite volume
H	✓	✓
K		✓ -

Which of the following about substances H and K is correct?

- (1) Both substances can be compressed.
- (2) Both substances take the shape of a container.
- (3) Substance H is a liquid but substance K is a gas.
- (4) Substance H is a solid but substance K is a liquid.

11 The diagrams below show the water level before and after marbles are placed in a beaker of water.

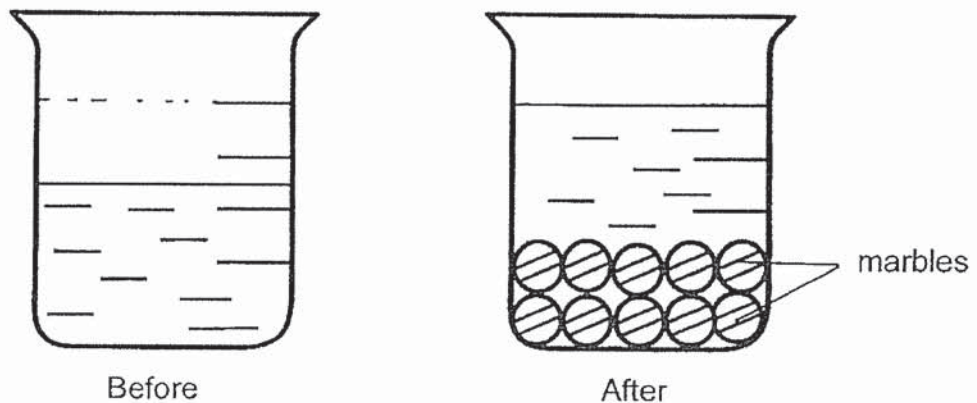

Which one of the following explains the rise in water level in the beaker?

- (1) Marbles have mass.
- (2) Marbles occupy space.
- (3) Marbles have definite shape.
- (4) Marbles cannot be compressed.

- 12 Four materials, W, X, Y and Z, were tested for their strength. Different number of weights were placed on each material till it broke.

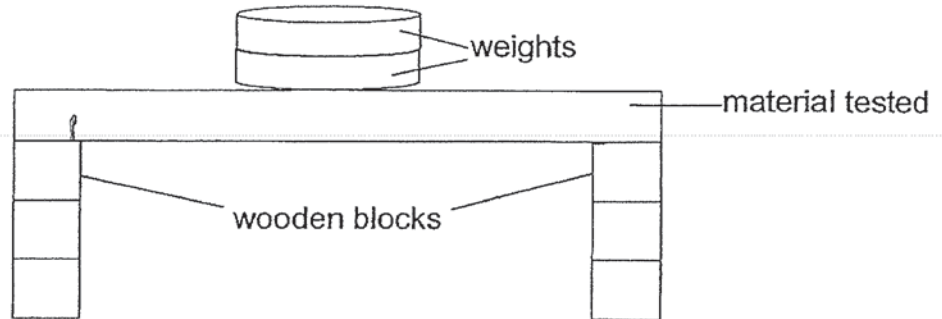

Which of the following must be kept the same for a fair test?

- A type of material tested
  - B thickness of the materials tested
  - C number of weights added to the material tested
- (1) A only  
(2) B only  
(3) B and C only  
(4) A, B and C

13 Study the diagram below.

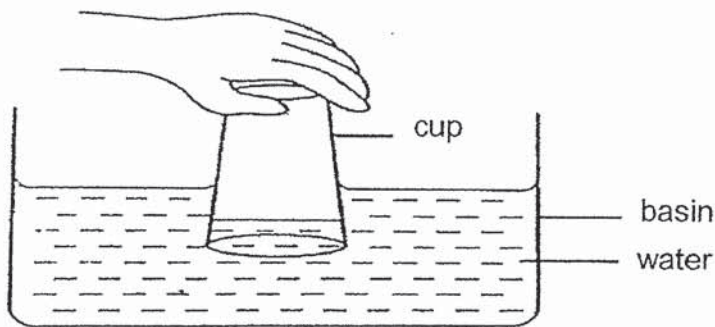

The water level is lower in the cup than in the basin because \_\_\_\_\_.

- (1) air can be compressed
- (2) air in the cup takes up space
- (3) water cannot be compressed
- (4) water does not have a definite shape

14 The diagram below shows an air pump connected to a glass tank.

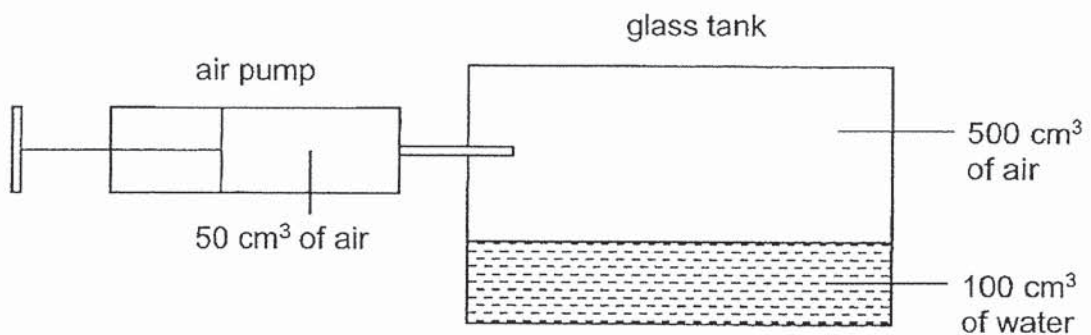

What is the volume of air in the glass tank after 50 cm<sup>3</sup> of air is pumped into the glass tank?

- (1) 50 cm<sup>3</sup>
- (2) 500 cm<sup>3</sup>
- (3) 550 cm<sup>3</sup>
- (4) 600 cm<sup>3</sup>

15 Mark tested the amount of light that can pass through four different materials, A, B, C and D, using the set-up below.

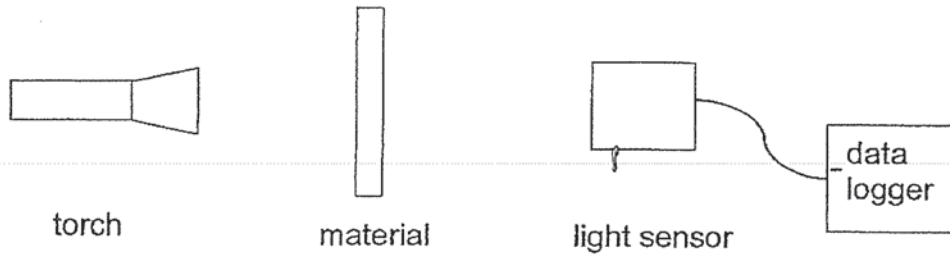

The graph below shows his results.

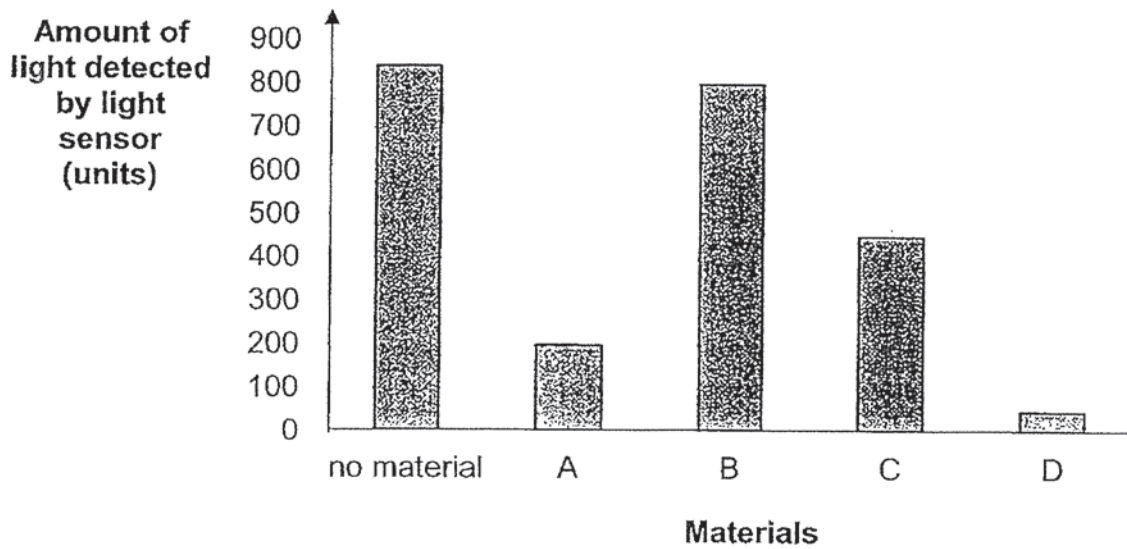

Which material should Mark choose to make the lens of a pair of spectacles?

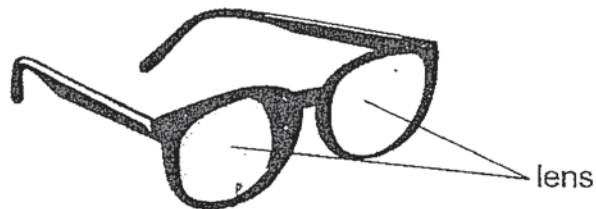

- (1) Material A
- (2) Material B
- (3) Material C
- (4) Material D

16 The flow chart below shows the properties of three matters, A, B and C.

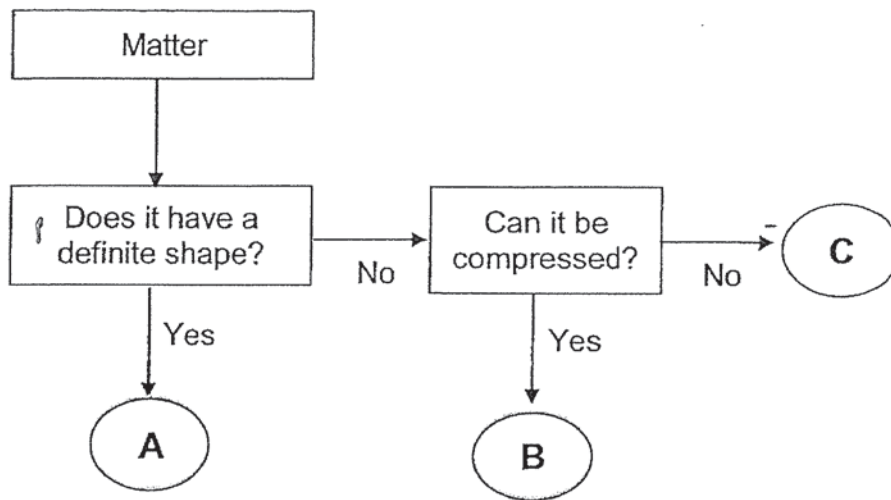

Which of the following can A, B and C be?

	A	B	C
(1)	air	book	milk
(2)	milk	air	book
(3)	book	air	milk
(4)	book	milk	air

17 A nail was magnetised using the stroke method.

Which of the following statements about the stroke method is **wrong**?

- (1) The nail must be a magnetic material.
- (2) The nail must be stroked in the same direction.
- (3) The nail must only be stroked with the North Pole of the magnet.
- (4) The more strokes on the nail, the stronger the magnetism of the nail.

18 Bala arranged three magnets such that one end is attracted to another end as shown below.

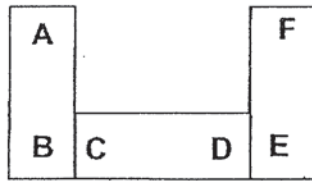

Which of the following is another possible arrangement?

(1)

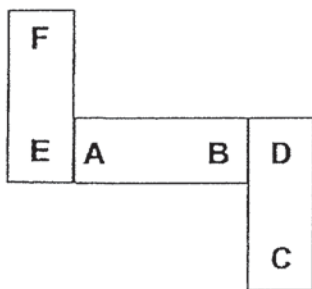

(2)

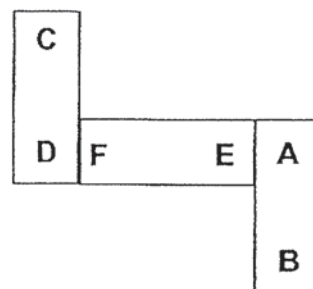

(3)

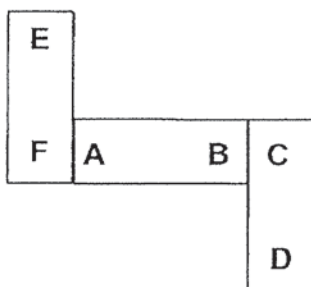

(4)

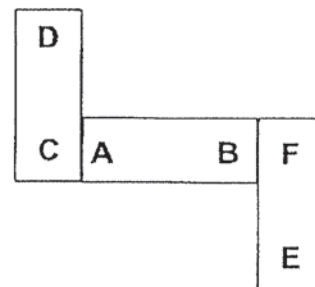

- 19 Containers A and B have the same volume. Container A is completely filled with water as shown in the diagram below. All the water from A is poured into B.

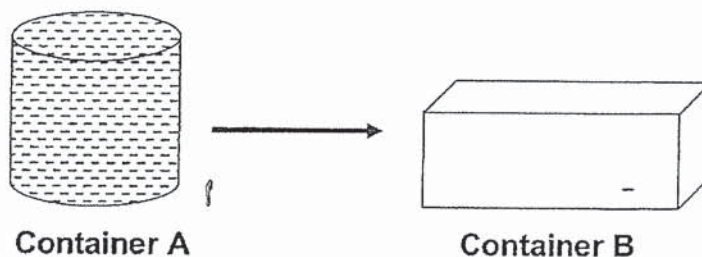

Which of the following explain(s) why the water did not overflow in B?

- A Water takes up space.
- B Water has a definite volume.
- C Water does not have a definite shape.

- (1) A only
- (2) A and C only
- (3) B and C only
- (4) A, B and C

- 20 Sophie dropped a bar magnet and it broke into two pieces.



What are the poles of parts B and C on the two pieces of broken magnet?

	<b>B</b>	<b>C</b>
(1)	North	North
(2)	South	South
(3)	North	South
(4)	South	North

21 Which one of the following correctly shows the direction of a freely suspended bar magnet when it is at rest?

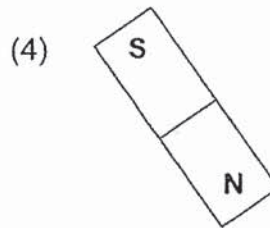
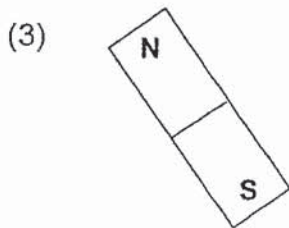
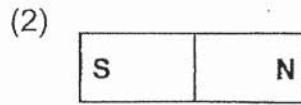
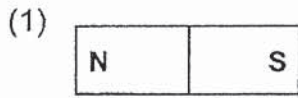

22 The picture below shows how a magnetic door stopper is fixed to a door and wall to prevent the door from closing due to strong wind. The magnet attracts part X.

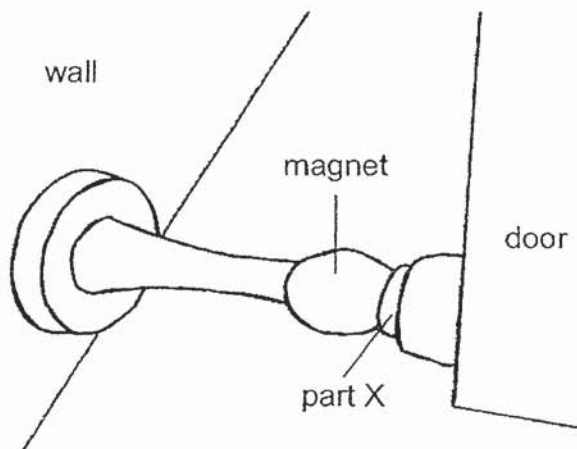

Which material can part X be made of?

- (1) iron
- (2) wood
- (3) plastic
- (4) copper



- 23 Four bars, A, B, C and D, are hung to a rod using strings. The picture below shows the observations made.

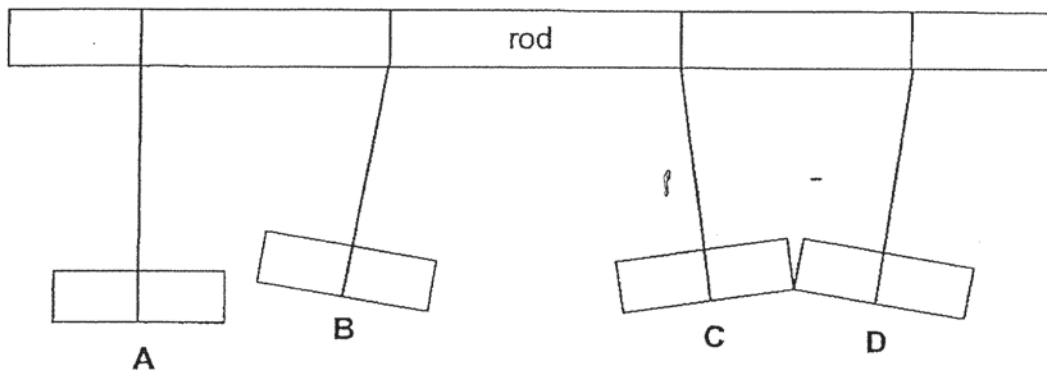

Only two of the four bars are magnets.

Which bars are magnets?

- (1) A and B
- (2) B and C
- (3) C and D
- (4) A and D

24 Four electromagnets made from identical metal rods are shown below.

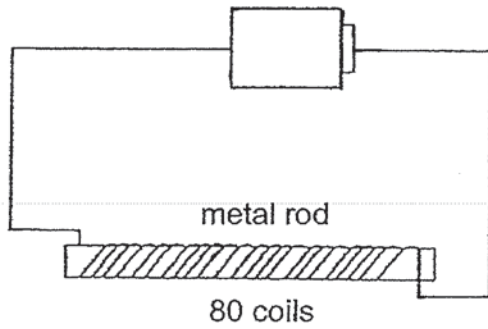

**Set-up A**

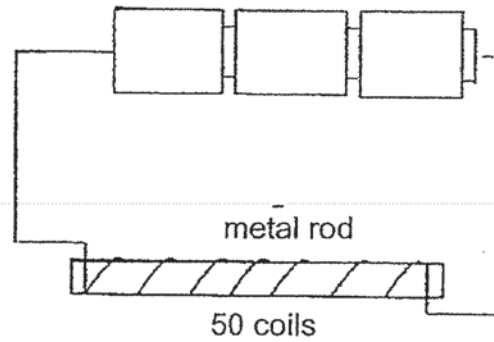

**Set-up B**

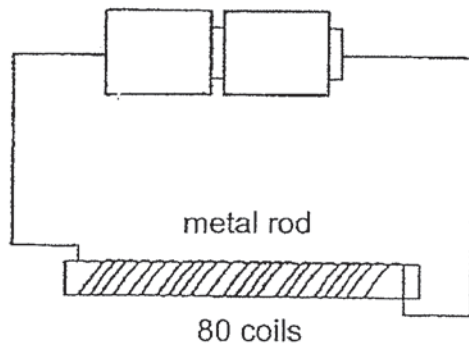

**Set-up C**

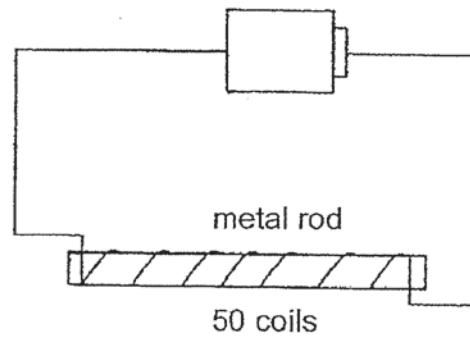

**Set-up D**

Daniel wants to find out if the number of coils around the metal rod will affect the magnetism of the electromagnet.

Which two set-ups should he use for his experiment?

- (1) A and C
- (2) A and D
- (3) B and C
- (4) B and D

**End of Booklet A**



MARIS STELLA HIGH SCHOOL (PRIMARY)

SA1 EXAMINATION

SCIENCE

16 MAY 2019

BOOKLET B

NAME: \_\_\_\_\_ ( )

CLASS: Primary 4 ( )

10 questions

32 marks

Total Time for Booklets A & B: 1 h 30 min

DO NOT OPEN THIS BOOKLET UNTIL YOU ARE TOLD TO DO SO.

FOLLOW ALL INSTRUCTIONS CAREFULLY.

Booklet A: \_\_\_\_\_ / 48

Booklet B: \_\_\_\_\_ / 32

Grand Total: \_\_\_\_\_ / 80

Parent's Signature: \_\_\_\_\_

For questions 25 to 34, write your answers in this booklet. The number of marks available is shown in brackets [ ] at the end of each question or part question. **(32 marks)**

25 The table below shows how some animals are classified.

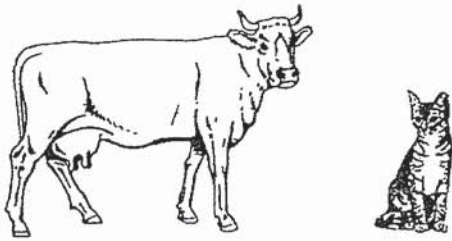
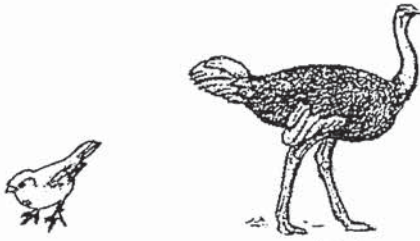
P	Q
 <p data-bbox="363 846 427 875">cow</p> <p data-bbox="651 846 699 875">cat</p>	 <p data-bbox="874 846 986 875">sparrow</p> <p data-bbox="1168 846 1264 875">ostrich</p>

(a) Which animal groups do animals in P and Q belong to? [2]

P: \_\_\_\_\_

Q: \_\_\_\_\_

(b) State the difference between the animals in group P and group Q in terms of their outer covering. [1]

\_\_\_\_\_

\_\_\_\_\_

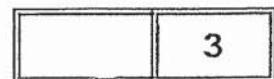

26 Animal K has adult, egg and young stages in its life cycle.

(a) Complete the life cycle of animal K by filling in **egg** and **young** in the life cycle below. [1]

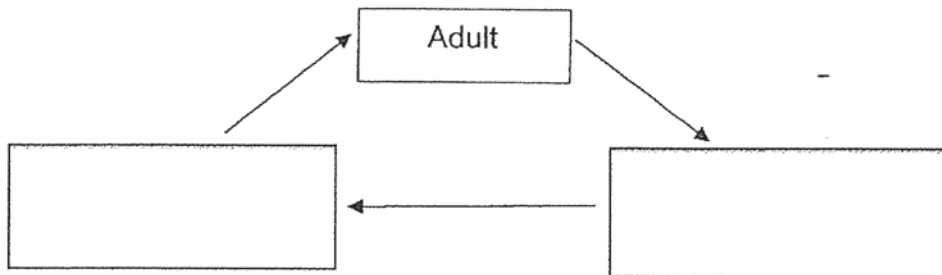

Life cycle of animal K

(b) How is the life cycle of a flowering plant and animal K similar? [1]

---

---

(c) Why are life cycles important? [1]

---

---

- 27 The table below shows the properties of three different materials, X, Y and Z. A tick (✓) indicates that the property is present.

Properties of Materials	Materials		
	X	Y	Z
strong	✓	✓	✓
flexible	✓		✓
waterproof			✓

Kenny wants to pitch a tent for outdoor camping. The tent is as shown below.



- (a) Which material, X, Y or Z is the most suitable for making part A of the tent? [1]

---

- (b) Kenny does not want others to see him from outside the tent.

Which other property must the material have?

[1]

---

(c)(i) Which of the following material is the most suitable for making part B of the tent?  
Put a tick (✓) in the correct box below. [1]

paper

metal

fabric

(ii) Explain your choice in (c)(i). [1]

---

---

28 Read the statements about the human digestive system.

Write 'T' for true or 'F' for false for each statement. [2]

	Statements	T or F
(a)	Excess water is absorbed at the large intestine.	
(b)	Saliva makes the food soft so that it is easy to swallow.	
(c)	Food moves from the large intestine to the small intestine.	
(d)	Digested food pass through the walls of the large intestine into the blood and is carried to all parts of the body.	

29 Study the life cycles of the grasshopper and butterfly shown below.

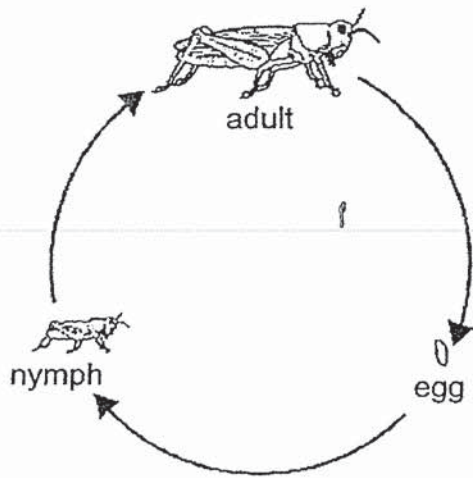

**Grasshopper Life Cycle**

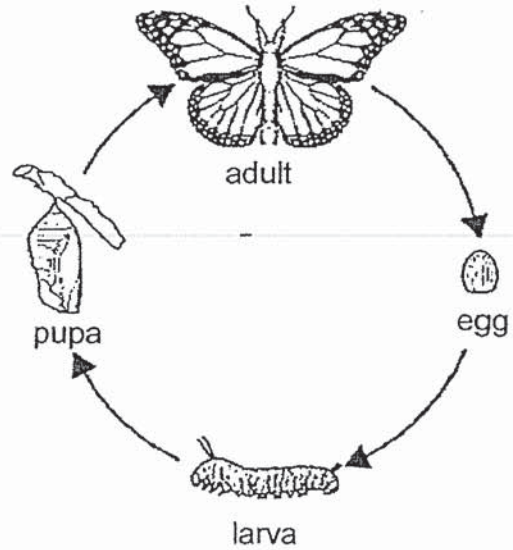

**Butterfly Life Cycle**

- (a) State two differences between the life cycles of the grasshopper and the butterfly. [2]

Difference 1: \_\_\_\_\_

\_\_\_\_\_

Difference 2: \_\_\_\_\_

\_\_\_\_\_

- (b) State one difference between the larval and pupal stages of the butterfly. [1]

\_\_\_\_\_

\_\_\_\_\_



30 Two balloons are tied to the ends of a balance as shown.

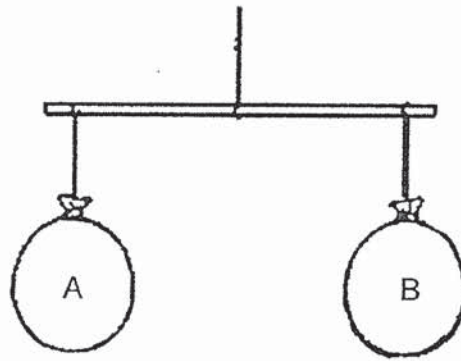

When the air in balloon A is released and balloon B is left as it is, the balance tilted towards one side.

(a) Which side, A or B, did the balance tilt towards? Why? [1]

---

---

Joshua packed some clothes into a bag as shown in diagram 1. The mass of the bag of clothes in diagram 1 is 4 kg. Joshua sucked the air out from the bag and sealed it, creating a vacuum bag, as shown in diagram 2.

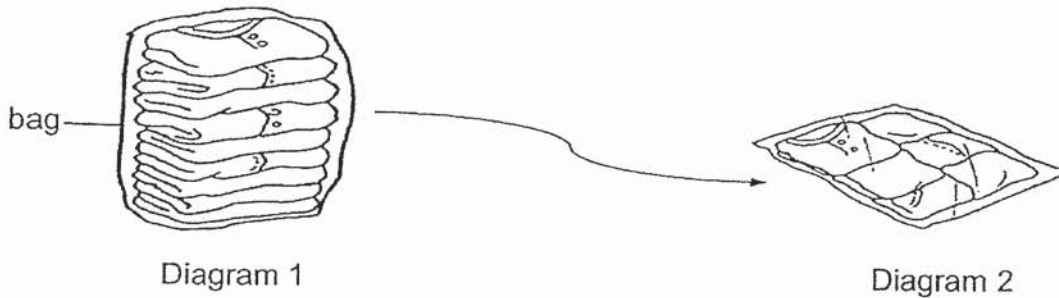

(b) Applying what is learnt in (a), predict if the bag of clothes in diagram 2 weighs more than, less than or equal to 4 kg? Explain your answer. [2]

---

---

- 31 Andy had two identical tins, A and B, containing paint. He punched one hole through tin A and two holes through tin B as shown in the diagrams below.

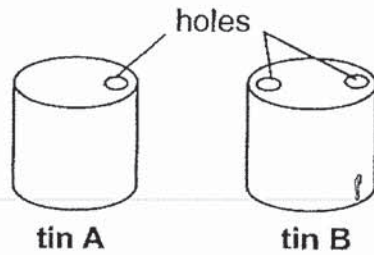

He then tilted both tins at the same angle as shown below.

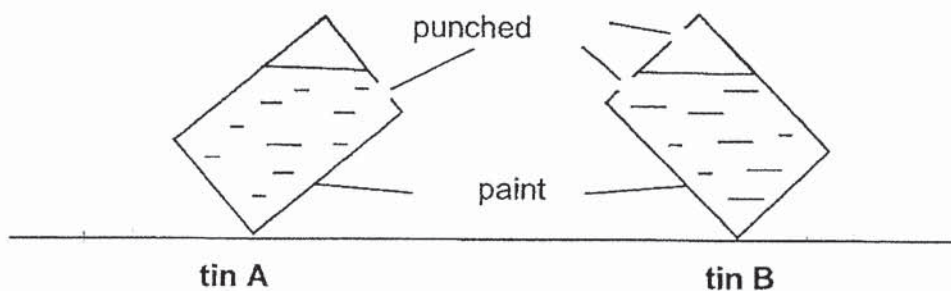

- (a) The paint in tin B flowed out faster than the paint in tin A. Explain why. [2]

---



---

Andy poured water through the funnel into the bottle as shown in the diagram below. He noticed that the water flowed in very slowly.

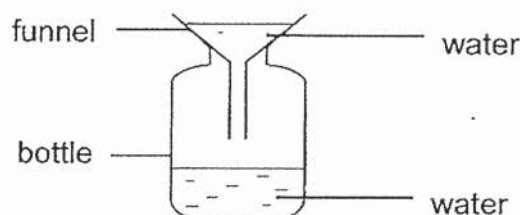

- (b) Using the same items and without damaging the bottle, what can Andy do to allow the water to flow faster into the bottle? [1]

---

- 32 The diagrams below show what happened when a bar magnet is used to hold a piece of paper against boards S and T. The paper and bar magnet stayed on board S but fell off on board T.

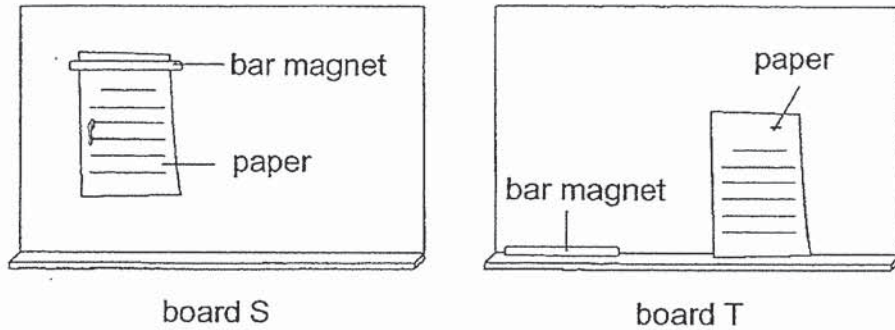

- (a) Based on the observations, identify the type of material used to make boards S and T? [2]

Board S: \_\_\_\_\_

Board T: \_\_\_\_\_

- (b) Based on the observation made on board S, state two properties of magnets. [2]

Property 1: \_\_\_\_\_

\_\_\_\_\_

Property 2: \_\_\_\_\_

\_\_\_\_\_

- 33 Jenny wants to find out if the number of times magnet A is dropped will affect its magnetism. The table below shows her results.

Number of times magnet A is dropped	Number of paper clips attracted
0	15
1	14
2	12
3	10
4	9
5	7

- (a) Name the variable that is changed in the experiment. [1]

\_\_\_\_\_

- (b) Based on the table above, what is the relationship between the number of times magnet A is dropped and the number of paper clips it can attract? [1]

\_\_\_\_\_  
\_\_\_\_\_

- (c) How is the magnetism of magnet A affected by the number times it is dropped? [1]

\_\_\_\_\_  
\_\_\_\_\_

- (d) Other than counting the number of paper clips magnet A can attract, suggest another method to test the magnetism of magnet A. [1]

\_\_\_\_\_  
\_\_\_\_\_

34 Matthias attached similar magnets to the top of two toy cars as shown below.

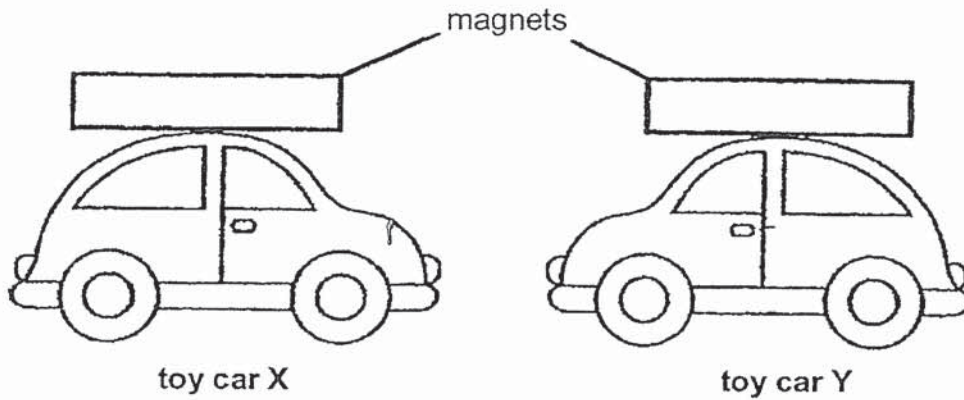

- (a) When toy car X was brought close to toy car Y, toy car Y moved away. Explain why toy car Y moved away from toy car X. [2]

---



---

Matthias turned toy car Y around such that the front of both toy cars are now facing the same direction as shown below. One of the poles of the magnet on toy car X is given.

- (b) Label the north and south poles of the magnet on toy car Y by filling in **N** and **S** on the magnet on toy car Y below. [1]

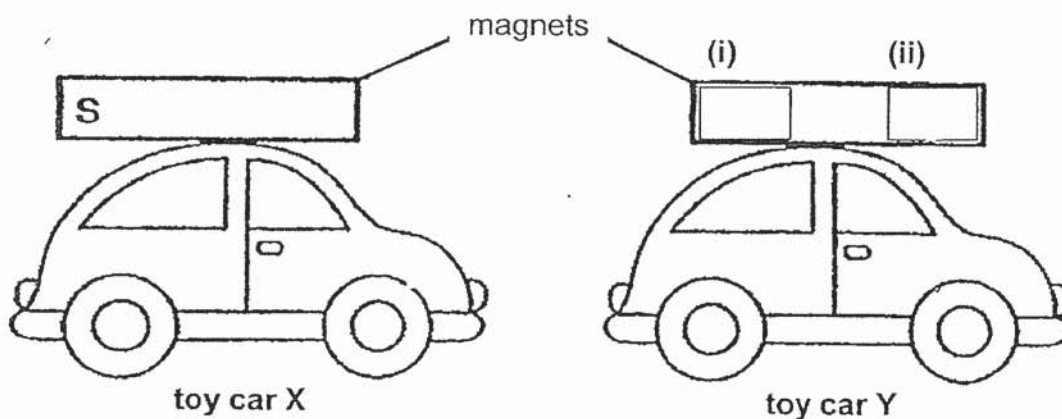

End of Booklet B

	3
--	---



# ANSWER KEY

YEAR : 2019  
LEVEL : PRIMARY 4  
SCHOOL : MARIS STELLA HIGH SCHOOL (PRIMARY)  
SUBJECT : SCIENCE  
TERM : SA1

## BOOKLET A

Q1	Q2	Q3	Q4	Q5	Q6	Q7	Q8	Q9	Q10
2	1	2	4	1	2	2	2	2	4
Q11	Q12	Q13	Q14	Q15	Q16	Q17	Q18	Q19	Q20
2	2	2	2	2	3	3	3	3	4
Q21	Q22	Q23	Q24						
3	1	2	2						

## BOOKLET B

- Q25 (a) P: Mammals  
Q: Birds  
(b) The animals group P has hair or fur but animals group Q has feathers.

Q26 (a)

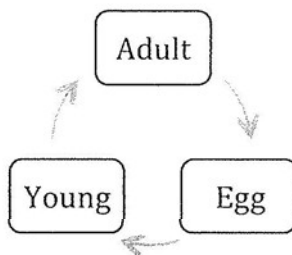

- (b) Both have 3-stages.  
(c) To ensure continuity of living things.
- Q27 (a) Material Z.  
(b) The tent must be opaque.  
(c) (i) metal  
(ii) It is the strongest.
- Q28 (a) T  
(b) T  
(c) F  
(d) F