



NANYANG PRIMARY SCHOOL

PRIMARY 4 SCIENCE

**SEMESTRAL ASSESSMENT 1
2015**

BOOKLET A

**Date : 12 May 2015
Duration : 1 h 45 min**

Name : _____

Class: Primary 4 ()

**DO NOT OPEN THIS BOOKLET UNTIL YOU ARE TOLD TO DO SO.
FOLLOW ALL INSTRUCTIONS CAREFULLY.**

Booklet A consists of 18 printed pages including this cover page.

Section A (30 x 2 marks = 60 marks)

For each question from 1 to 30, four options are given. One of them is the correct answer. Make your choice (1, 2, 3 or 4). **Shade the correct oval (1, 2, 3 or 4) on the Optical Answer Sheet provided.**

1. Which of the following examples **do not** show a living thing responding to changes in the environment?

- A A tree being chopped off.
- B A seedling growing towards sunlight.
- C A parrot flying towards its trainer to get food.
- D A balloon bursting when poked with a needle.

- (1) A and B only
- (2) A and D only
- (3) B and C only
- (4) C and D only

2. Study the classification chart below.

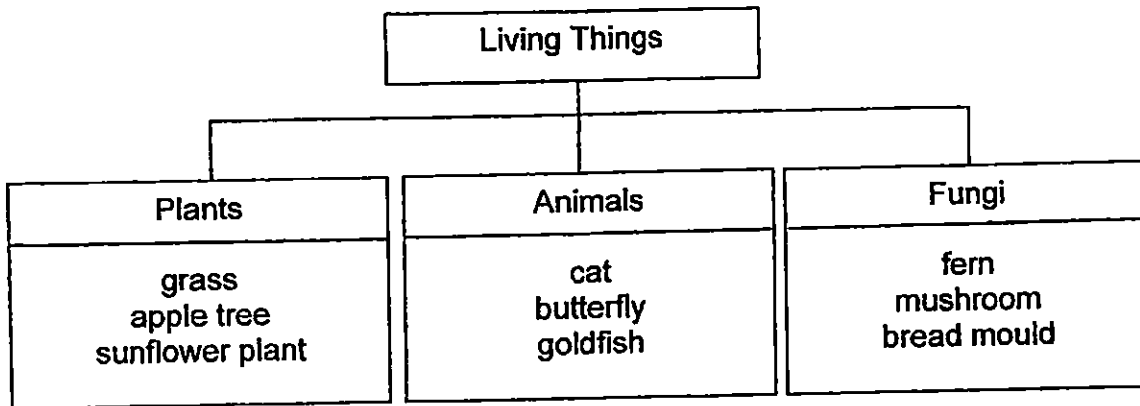

Which group(s) has/have a living thing that was wrongly classified?

- (1) Fungi only
- (2) Plants only
- (3) Fungi and Animals only
- (4) Plants and Animals only

3. The table below shows four living organisms that had been classified into two groups.

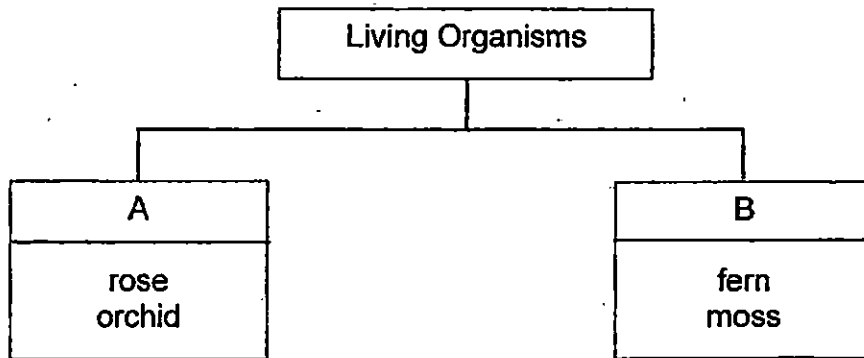

Which one of the following is a suitable heading for group A and B?

	A	B
(1)	bear flowers	do not bear flowers
(2)	live in water only	live on land only
(3)	makes its own food	does not make its own food
(4)	reproduce from spores	reproduce from seeds

4. The table below shows the characteristics of four animals, W, X, Y and Z.

Animal	lays eggs	has feelers	has an outer covering of feathers
W	No	No	No
X	Yes	No	Yes
Y	Yes	Yes	No
Z	Yes	No	No

Which one of the animals could most likely represent a turtle?

- 1) W
- 2) X
- 3) Y
- 4) Z

7. Study the two types of stems in the diagrams below.

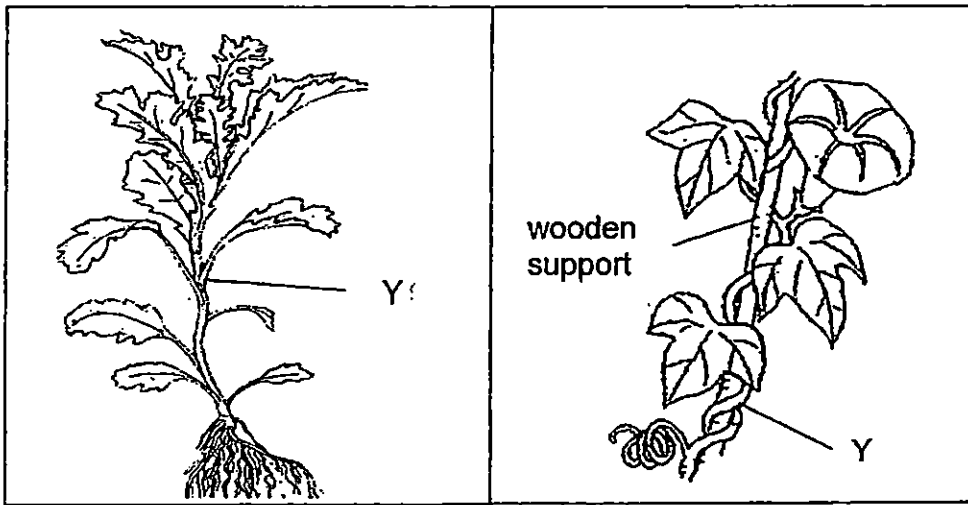

Plant E

Plant F

Which one of the following shows a correct function for part Y of plants E and F?

- (1) It produces fruits.
- (2) It supports the plant.
- (3) It absorbs water and minerals.
- (4) It holds the plant firmly to the ground.

8. Study the diagram below.

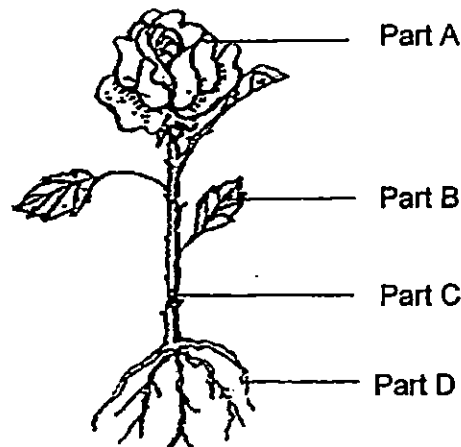

Which one of the following statements about the labelled plant parts is not true?

- (1) Part A can be found in all plants.
- (2) Part B traps light energy from the sun.
- (3) Part C holds the plant upright to get sunlight.
- (4) Part D absorbs water and minerals from the soil.

9. Which one of the following does not describe a human body system at work?

- (1) A boy kicking a ball.
- (2) A boy taking a deep breath.
- (3) A girl's hair moving in the wind.
- (4) A girl's heart beating faster as she jogs.

10. Look at the diagrams shown below.

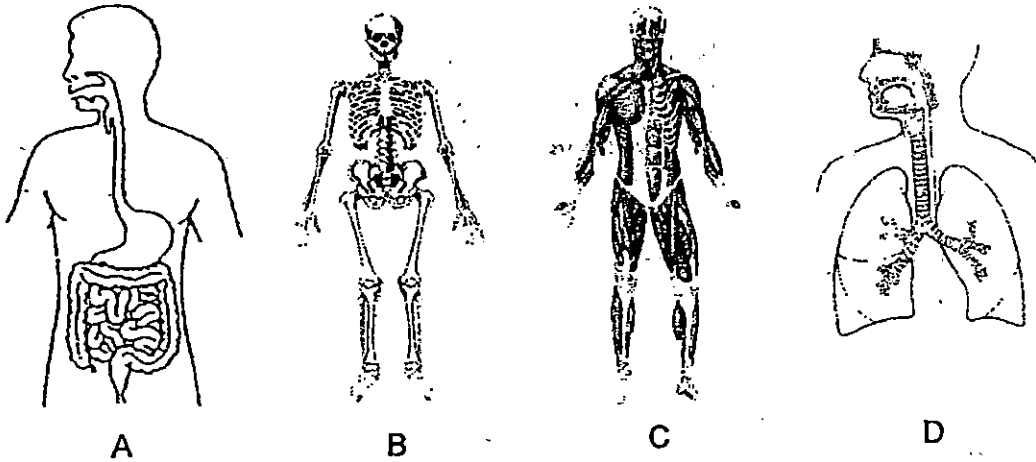

Which 2 systems above work directly together to enable us to stand upright?

- (1) A and B
- (2) A and D
- (3) B and C
- (4) C and D

11. Study the table below. Which one of the following sends digested food to different parts of the body?

	System	Part of System
(1)	digestive	water
(2)	respiratory	air
(3)	circulatory	blood
(4)	muscular	muscle

12. The diagram below shows the digestive system of the human body.

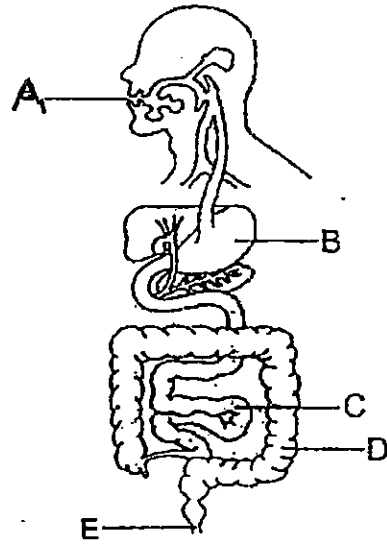

Which one of the following correctly identifies the body parts where digestion begins and ends?

	Digestion Begins	Digestion Ends
(1)	A	D
(2)	A	C
(3)	B	E
(4)	B	C

13. In the diagram below, the arrows represent the direction that the objects moved when they were placed near each other.

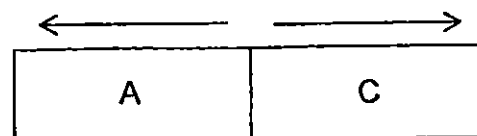
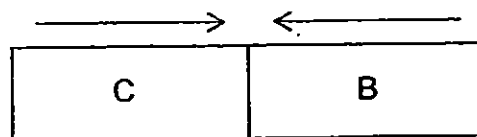
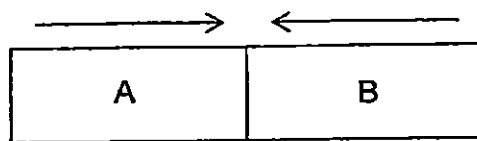

Which of the object(s) is/are definitely magnet(s)?

- (1) A only
- (2) B only
- (3) A and C only
- (4) B and C only

14. Study the four set-ups below. The same type of batteries, nail and wire had been used in each set-up.

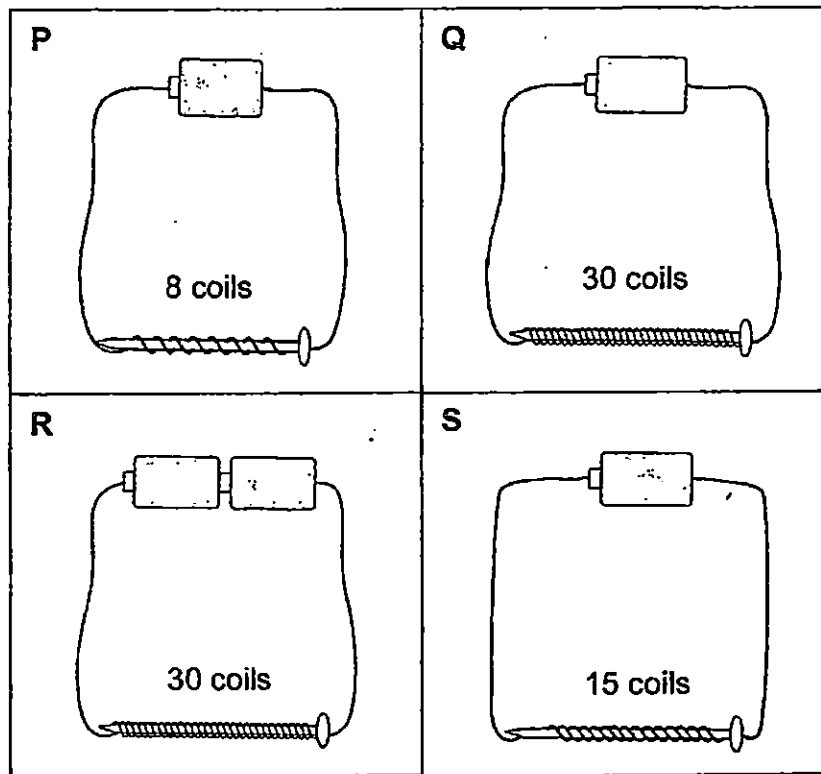

Arrange the set-ups in order, starting from the strongest to the weakest electromagnet.

	strongest	→	weakest
(1)	P,	S,	Q, R
(2)	Q,	R,	S, P
(3)	R,	Q,	P, S
(4)	R,	Q,	S, P

15. Which of the following are natural sources of light?

- A Sun
- B Stars
- C Moon
- D Firefly

- (1) A and B only
- (2) B and C only
- (3) A, B and D only
- (4) A, B, C and D

19. Damien looked into a mirror and saw the reflection of his pencil in it. Which diagram below shows the correct light ray that allowed the reflection to be seen?

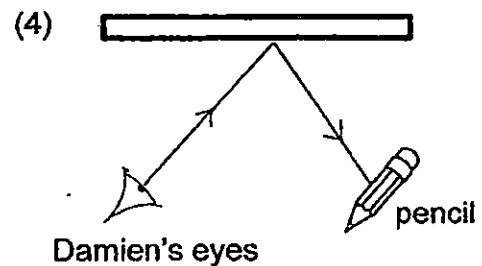
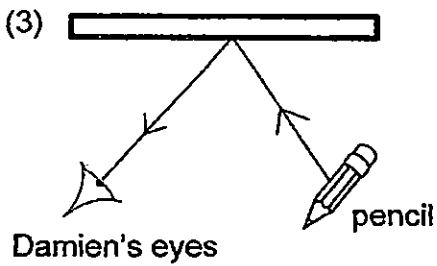
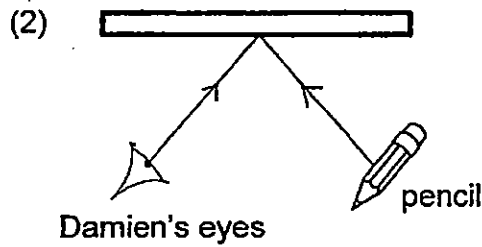
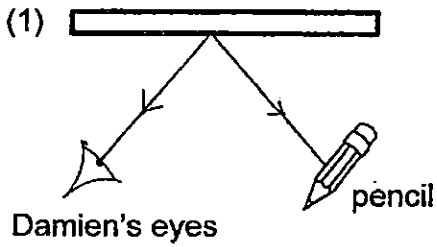

20. The experiment shown below was carried out in a dark room.

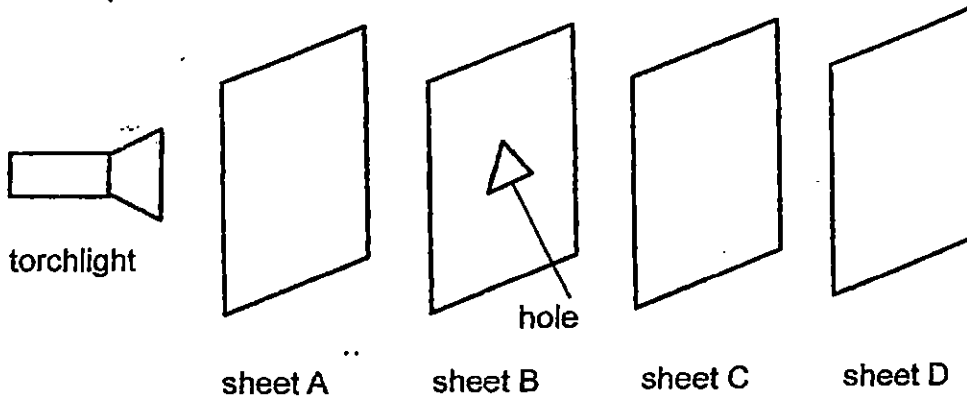

Sheets A, B, C and D were made of different materials and were arranged in a straight line. The torchlight was switched on and a bright triangular shaped patch of light was seen on sheet C only.

Which one of the following correctly describes the properties of the materials which sheets A, B, C and D are most likely made of?

	Allows light to pass through	Does not allow light to pass through	Not possible to tell
(1)	C	B and D	A
(2)	B	A	C
(3)	A	B and C	D
(4)	A and B	C	D

21. Study the diagram of an experiment below which was carried out in a dark room. A torchlight, a ball, a narrow pole and a screen were placed on a table in a straight line directly in front of each other. The torchlight was switched on and the direction of light was indicated below.

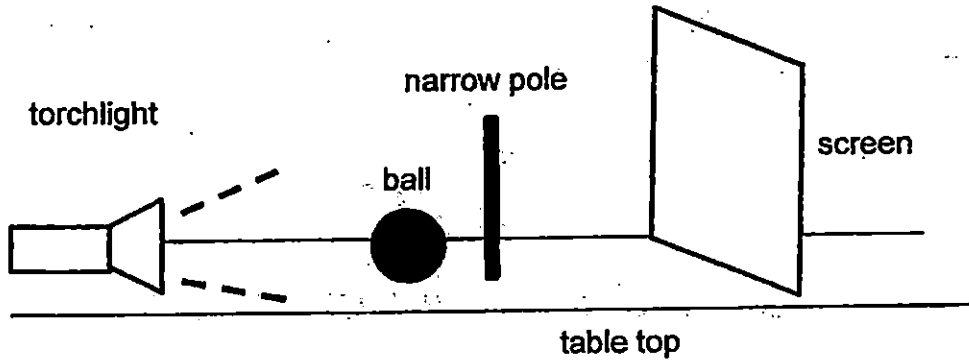

Which one of the following shadows could most likely be formed on the screen?

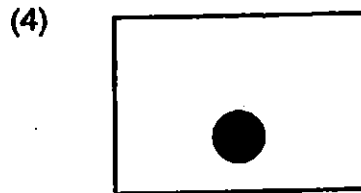
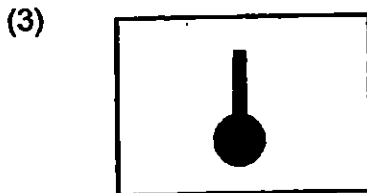
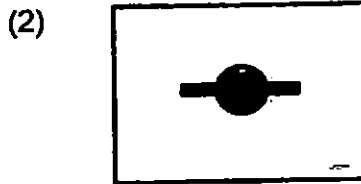
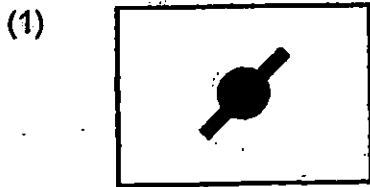

22. Rithi drew the shadow of a pole on the ground as shown below. Based on the position of the shadow, which one of the following diagrams correctly shows the most likely position of the Sun?

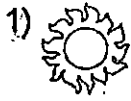

23. Which of the following can be classified as matter?

- A air
- B ant
- C flower
- D sunlight

- (1) A and C only
- (3) B, C and D only

- (2) A, B and C only
- (4) A, B, C and D

24. Jonathan lowered an empty glass with a piece of wood into a trough of water as shown below. He observed that the water level in the glass was lower than the water level outside the glass.

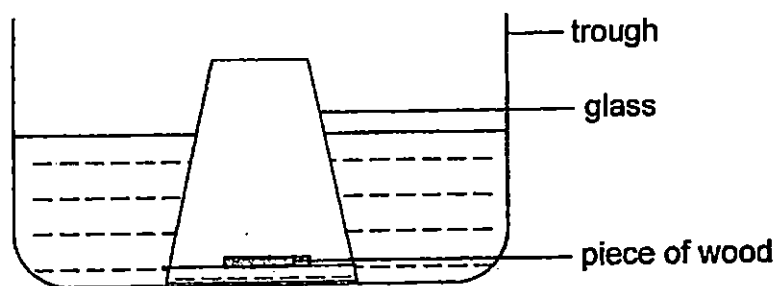

Which one of the following statements correctly explains Jonathan's observation?

- (1) The air in the glass dissolved in the water.
- (2) The piece of wood in the glass absorbed the water.
- (3) The piece of wood in the glass occupied space and compressed the water
- (4) The air in the glass occupied space and prevented more water from entering the glass.

25. Sarah placed three objects, X, Y and Z, in a measuring cylinder and filled it with water to the 200 cm^3 mark. She then removed the objects one by one, and recorded the water level in the measuring cylinder as shown below.

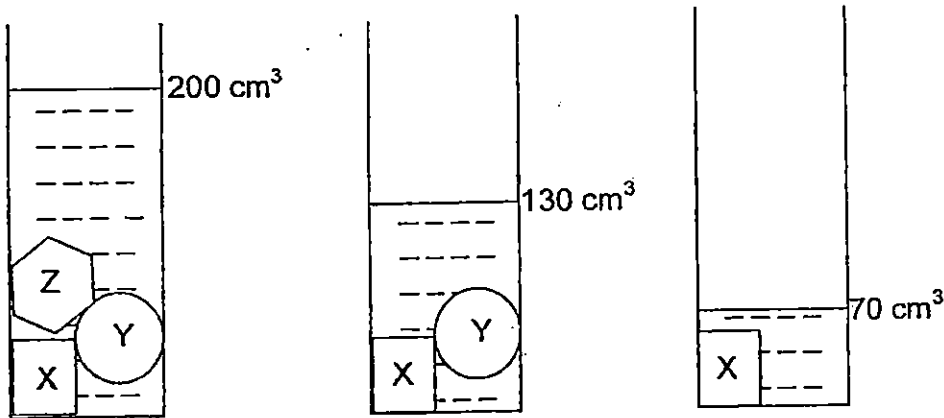

Based on the above, which of the following conclusions are true?

- A Object X has a volume of 70 cm^3 .
- B Object Y has a volume of 60 cm^3 .
- C Object Z occupies the largest space.

- (1) A and B only
- (2) A and C only
- (3) B and C only
- (4) A, B and C

26. Three objects, X, Y and Z were hung on two lever balances as shown below.

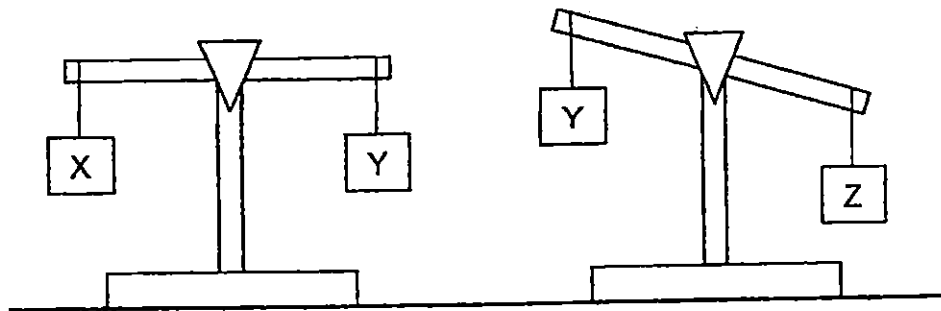

Based on the set-ups, which one of the statements about objects X and Y is false?

- (1) Object X has the least mass.
- (2) Object Z has the greatest mass.
- (3) Object X is lighter than object Z.
- (4) Object Y weighs less than object Z.

- (4) Most of the light passes through the window.

27. Study the flowchart below.

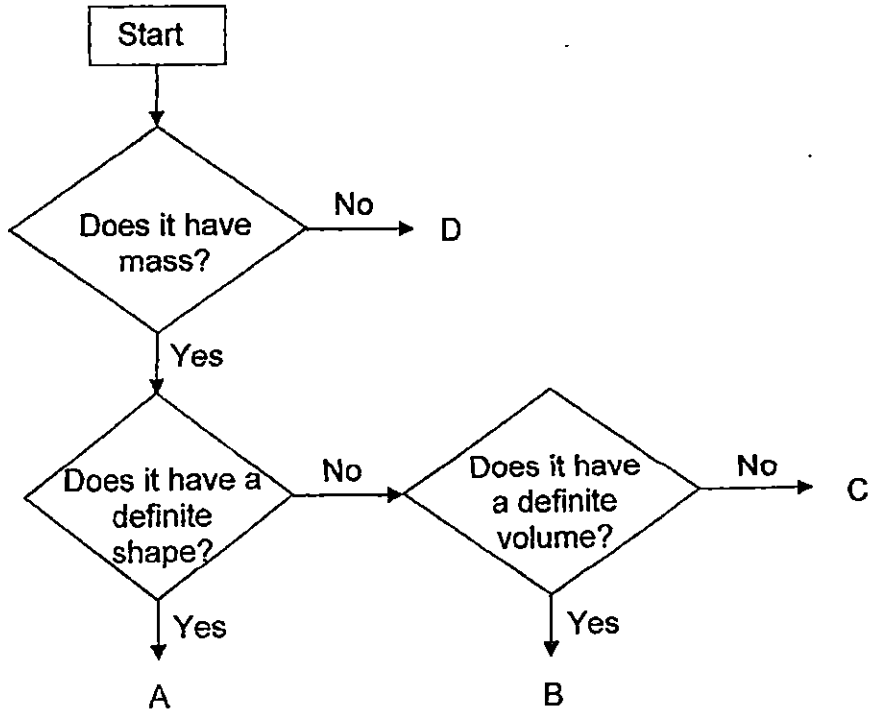

Based on the flowchart, which one of the following best represents A, B, C and D?

	A	B	C	D
(1)	marble	air	oil	shadow
(2)	oil	marble	shadow	air
(3)	shadow	air	marble	oil
(4)	marble	oil	air	shadow

28. Two identical beakers containing different substances, X and Y, were placed on a lever balance as shown below.

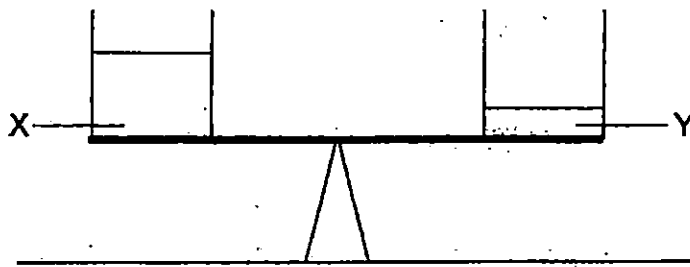

Based on the diagram above, which of the following conclusions can be made?

- A Substance Y occupies a greater space than substance X.
 - B There is a greater volume of substance X than substance Y.
 - C The mass of substance X is equal to the mass of substance Y.
 - D The mass of substance X is heavier than the mass of substance Y.
- (1) A and B only (2) A and D only
 (3) B and C only (4) B, C and D only

29. A syringe is filled with some air and water. The nozzle is tightly sealed as shown in the diagram below.

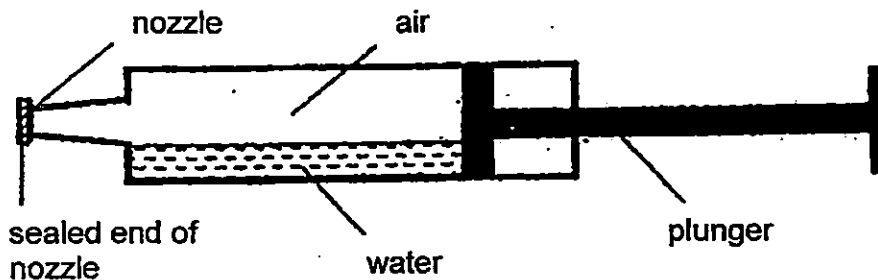

Kai Yang pushed the plunger with all his strength but to his surprise, it could not be pushed in fully.

Which of the following could be the reason(s) for his observation?

- A The air in the syringe occupied space.
 - B The air in the syringe could be compressed fully.
 - C The water in the syringe took the shape of the syringe.
 - D The water in the syringe occupied a definite amount of space.
- (1) A and C only (2) A and D only
 (3) B and C only (4) B and D only

30. Wenhao filled two containers with equal amounts of water. Then he placed objects G and H into a container each. He observed that the new water level for the containers were the same as shown in the diagram below.

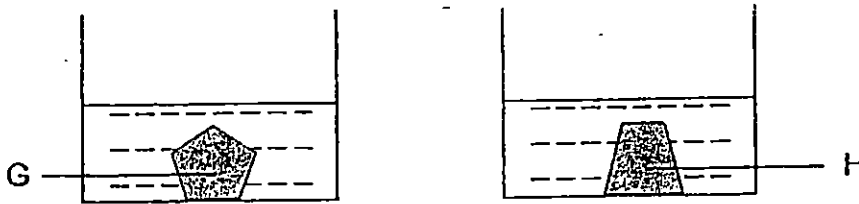

Which one of the statements about objects G and H is true?

- (1) They have equal mass.
- (2) They are buoyant in water.
- (3) They have the same volume.
- (4) They are made of the same material.



NANYANG PRIMARY SCHOOL

PRIMARY 4 SCIENCE

**SEMESTRAL ASSESSMENT 1
2015**

BOOKLET B

Date : 12 May 2015

Duration : 1 h 45 min

Name : _____ ()

Class: Primary 4 ()

Marks Scored:

Booklet A:	60
Booklet B :	40
Total :	100

Any query on marks awarded should be raised by 21st May 2015. We seek your understanding in this matter as any delay in the confirmation of marks will lead to delays in the generation of results.

Parent's signature:

**DO NOT OPEN THIS BOOKLET UNTIL YOU ARE TOLD TO DO SO.
FOLLOW ALL INSTRUCTIONS CAREFULLY.**

Booklet B consists of 16 printed pages including this cover page.

Section B (40 marks)

Write your answers to questions 31 to 44 in the spaces provided.

31. Erin bought two hamsters and kept them in two containers for two weeks as shown below.

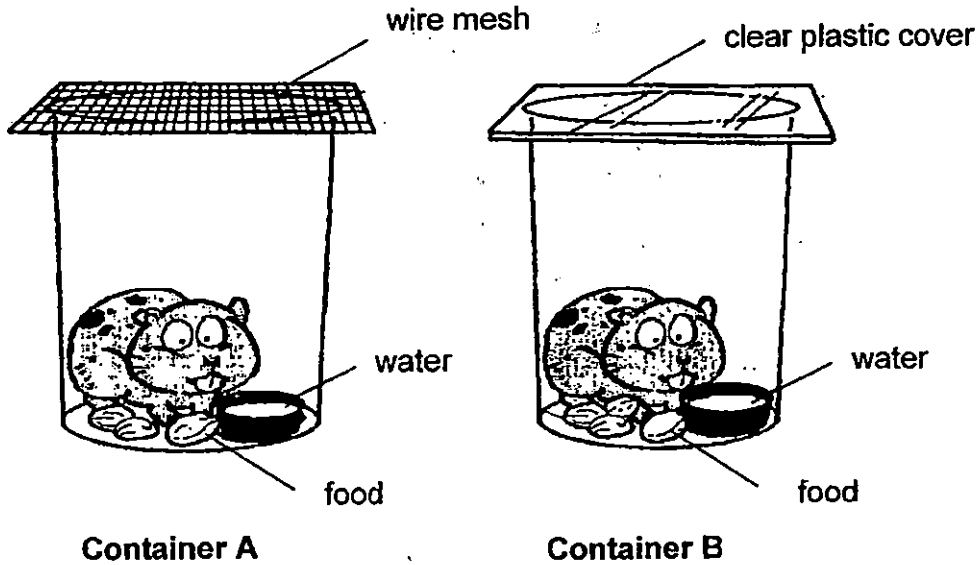

- (a) Based only on the information provided, which hamster will most likely not survive? [1]

- (b) Explain your answer in (a). [1]

- (c) Besides needing air, food and water, state one similarity in characteristic between a rose plant and the hamster. [1]

32. Debbie was given an organism X. It had green leaves and reproduced by spores. She kept it in a dark closed cupboard for one week and watered it daily.

A week later, organism X died.

(a) Give a reason why organism X died after one week. [1]

(b) Would organism X be classified as a flowering plant? Give a reason for your answer. [1]

(c) Give an example of organism X based on its characteristics. [1]

33. Study the classification chart below.

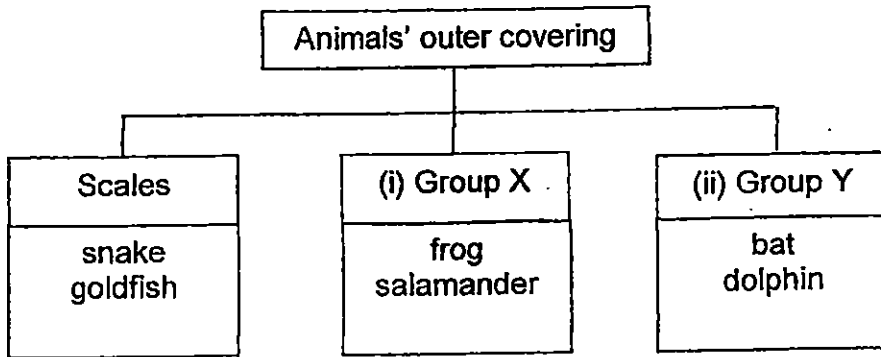

(a) State the outer covering of the animals in Group X and Y. [1]

(i) X: _____

(ii) Y: _____

(b) State one other difference in characteristic between the animals found in group X and Y. (Do not mention their outer covering) [1]

(c) Jacob could not include animal M into the classification chart above as it has a hard outer covering.

Which group of animals does animal M most likely belong to? [1]

(d) Based on its outer covering, state two other most likely characteristics of animal M. [1]

(i) _____

(ii) _____

34. Li Ming placed a plant in a beaker containing 150ml of water. He recorded the amount of water left in the beaker each day.

Day	0	1	2	3	4
Amount of water left in the beaker (ml)	150	130	110	90	70

- (a) Based on his results, how does the number of days affect the amount of water left in the beaker? [1]

- (b) Why did the amount of water in the beaker get lesser and lesser each day? [1]

The diagram below shows some plants that were grown on a steep slope.

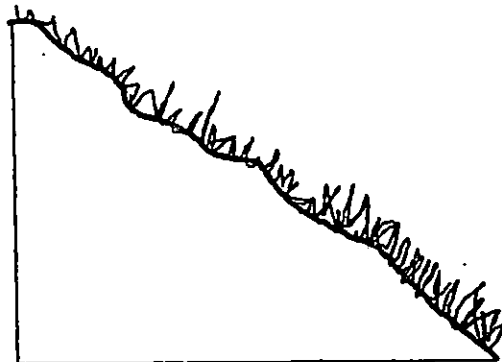

- (c) Explain why some plants can be grown on steep slopes and they are not washed away during a heavy thunderstorm. [1]

35. The diagram below shows the human digestive systems.

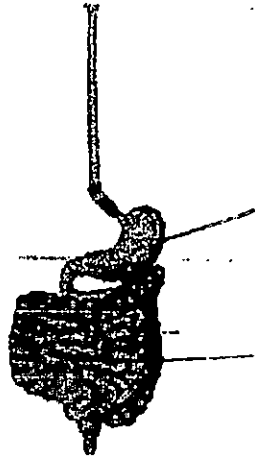

Human digestive system

(a) State the function of the digestive system. [1]

(b) On the diagram above, label two organs that produce digestive juices. [1]

The process of chewing helps us to cut up our food into smaller pieces before swallowing. However, the elderly often do not have many teeth. They are usually advised to eat soft, mushy food.

(c) How would eating such food help them in digestion? [1]

36. Sam made an iron nail into a temporary magnet using the stroking method. After that, he recorded the number of pins that the temporary magnet could pick up. Using the same magnet, he repeated the experiment with another identical iron nail.

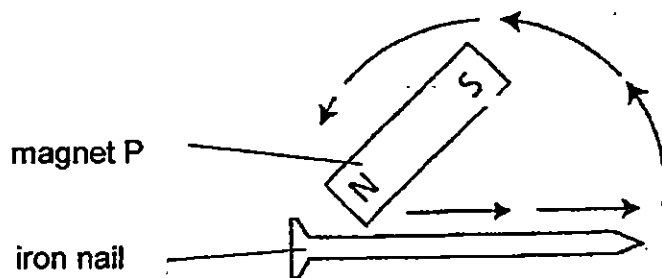

	1 st iron nail	2 nd iron nail
Number of pins picked up	4	10

- (a) What did Sam most likely do to the iron nail which enabled it to pick up more pins in the second experiment? [1]

Sam discovered two unidentified objects, S and T, in his drawer. He wants to find out if these objects are magnets. He used the set-up shown below.

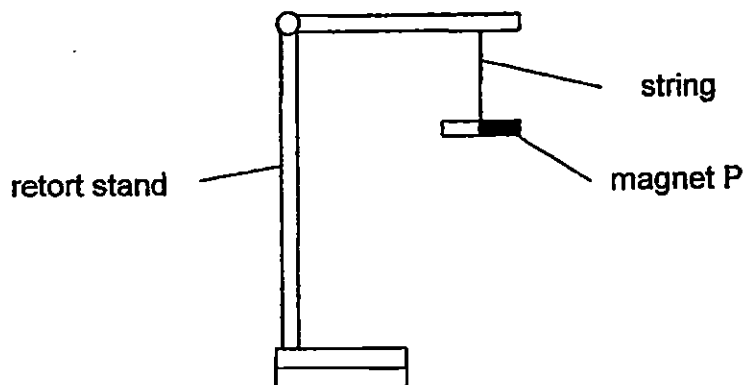

- (b) In which direction would the freely-suspended magnet P be pointing to? [1]

He brought objects S and T close to magnet P. He observed that one end of object S repelled magnet P while the other end was attracted to the same pole of magnet P. Object T was attracted to both poles of the same magnet.

(c) i) What can he conclude about object S based on his observation?
Explain your answer.

Object S: _____ [1]

Reason:

ii) Give an example of a material that object T could be made of. [1]

37. Read the following statements carefully. Write "T" (True) in the brackets for a correct statement and "F" (False) for an incorrect statement. [2]

- (a) Light is a type of matter. ()
- (b) We can see without light. ()
- (c) Objects reflect light which enables us to see them. ()
- (d) Shadows are formed when light bends around objects. ()

38. In the experiment below, a shiny metal can was placed on a table between a torch light and a screen.

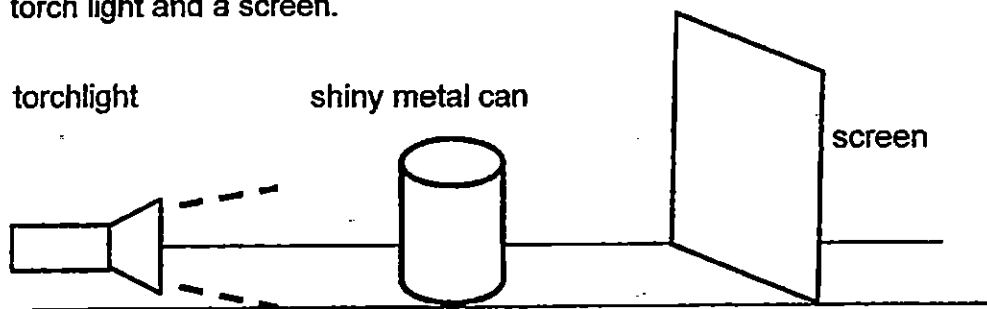

In the space below, draw **2 possible shadows** which can be produced on the screen. (The can may be rotated to produce the shadows.) [2]

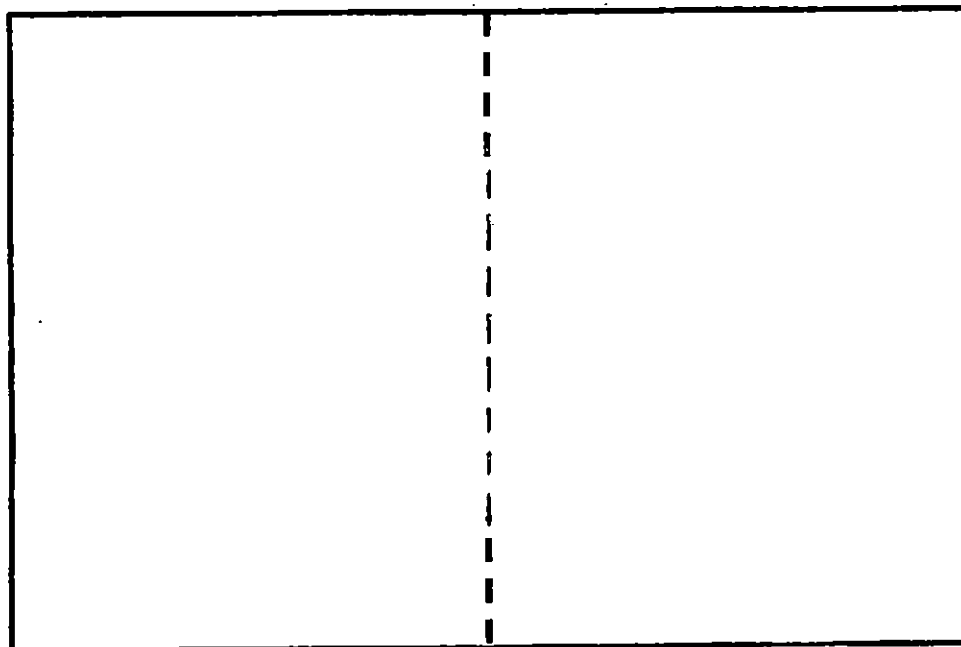

- (a) Joseph stood in an open field during the day. He observed that his shadow was at different positions at different times of the day. Explain his observation. [1]

At night, Joseph placed 2 narrow poles in a room and observed the positions of their shadows. There was a lamp fixed to the ceiling above the pole as shown below.

- (b) Draw the two shadows of the poles that can be observed. [1]

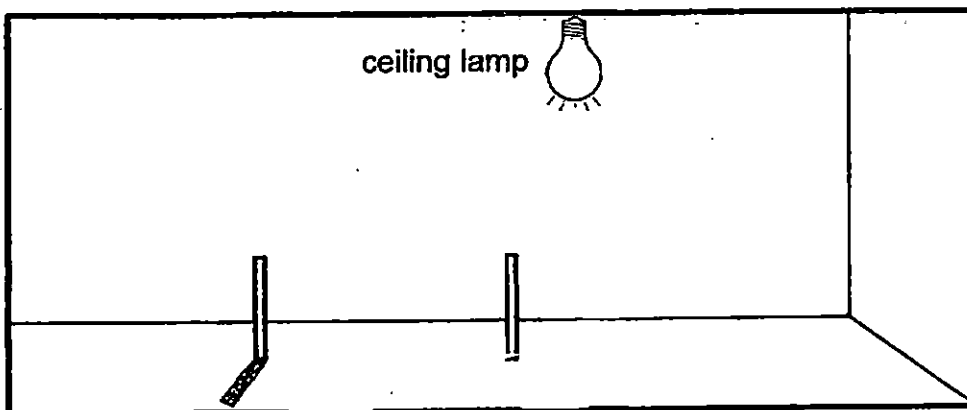

40. Alan conducted the experiment below in a dark room and used a light sensor to test the amount of light which passed through various materials.

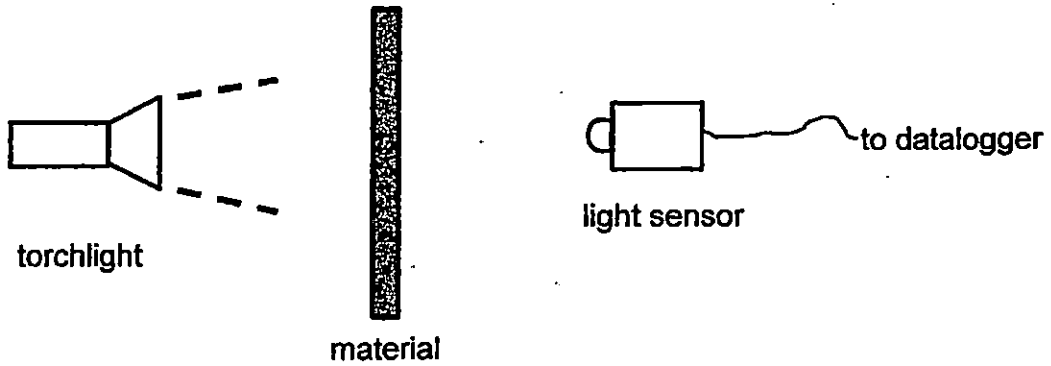

The results of his experiment are shown in the table below.

Material	Light sensor reading
none	200
P	90
Q	180
R	0

Alan had used a clear glass sheet, a piece of writing paper and a ceramic tile in his experiment.

- (a) Based on his results, match the materials he had used with materials P, Q, and R. [3]

a clear glass sheet : _____

a piece of writing paper : _____

a ceramic tile : _____

Alan noticed that his shadow was cast on the wall behind him when he stood in front of the torchlight.

- (b) Without moving the torchlight, what could Alan do to make his shadow larger? [1]

41. A displacement can, a measuring cylinder and some water can be used to find the volume of a rock.

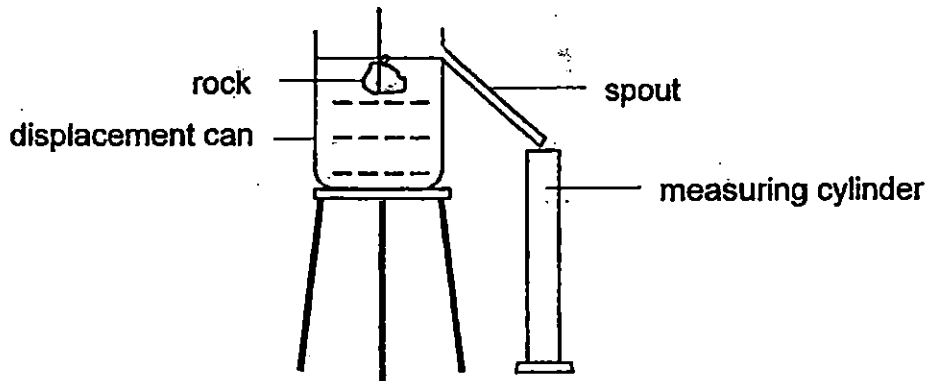

- (a) In the boxes below, write '1, 2, 3 or 4' to arrange the steps needed to find the volume of the rock. [1]

- (i) Place your eye at the water level of the measuring cylinder to find the volume of the rock.
- (ii) Tie the rock to a string and lower it into the displacement can.
- (iii) Fill the displacement can with water until it starts to flow out from the spout.
- (iv) Place the measuring cylinder under the spout to contain the water flowing out from the spout.

- (b) What property of the rock is being used to find its volume using this method? [1]

42. An airtight container with a capacity of 500 cm^3 was used to hold substance K.

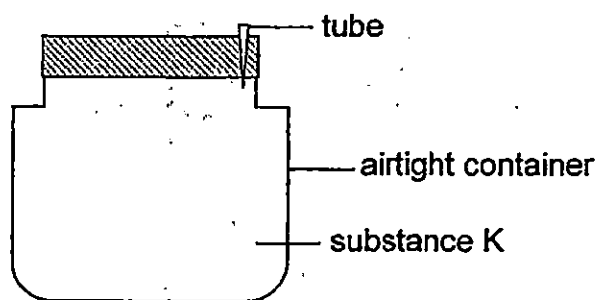

The table below shows the mass and volume of substance K in the container as more of it was added into the container.

Mass (g)	20	22	24	26	28
Volume (cm^3)	500	500	500	500	500

- (a) Which state is substance K found in during the experiment? [1]

- (b) Explain your answer to (a). [1]

43. Haiwen was given 50 cm^3 of plasticine and 100 cm^3 of water in a beaker.

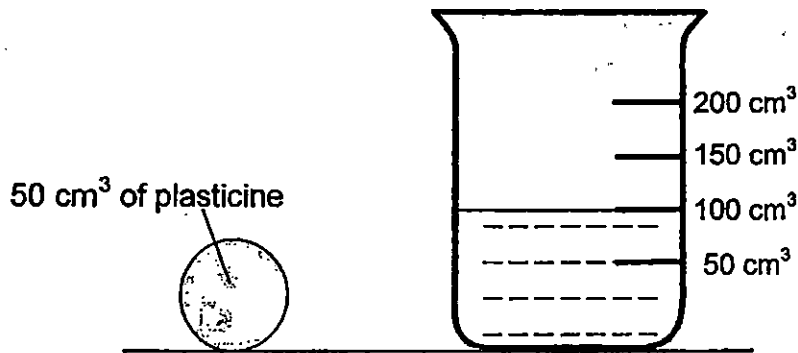

- (a) In the diagram below, draw in the water level in the beaker when the plasticine was placed into the beaker of water. [1]

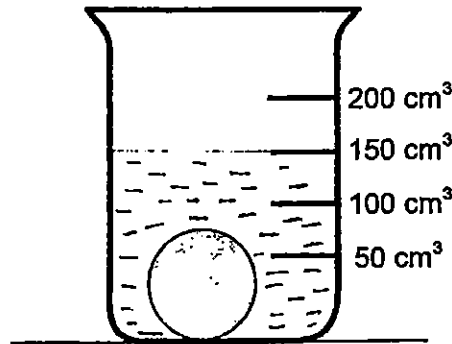

Haiwen flattened the 50 cm^3 of plasticine and placed it into the beaker of 100 cm^3 of water again.

- (b) Will the water level be the same as what was drawn in (a)?
Give a reason for your answer. [1]

44. Sze Tong carried out an experiment to find out how the size of a hole made in a bottle affected the rate at which detergent could be poured into the bottle.

She took three identical bottles and fitted a funnel on each of them, sealing the parts together with plasticine. Then she made a hole of different sizes at the same position of each bottle, as shown in the diagram below.

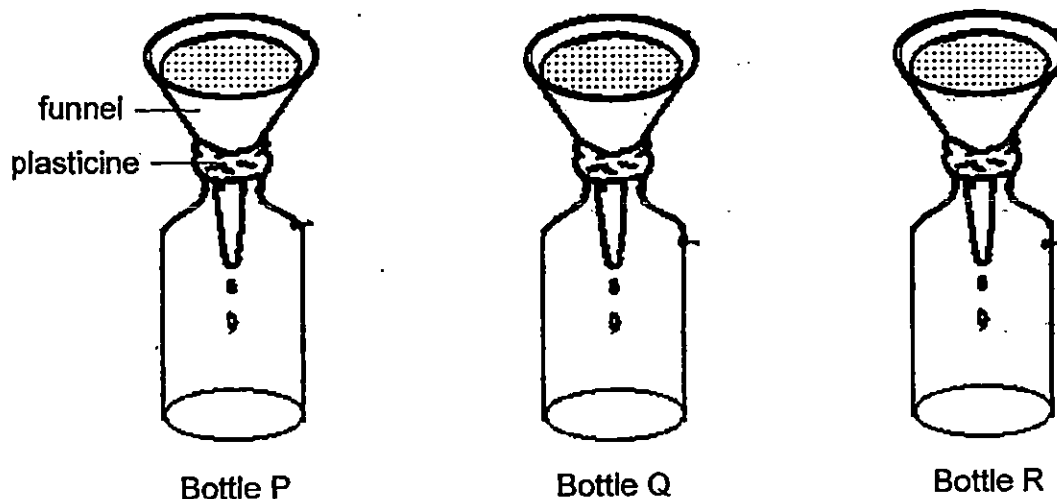

She poured 500 ml of detergent into the first funnel and recorded the time taken for the detergent to fill the bottle. She repeated this step with the other two bottles.

The results of her experiment are shown in the table below.

Bottle	P	Q	R
Size of hole made in bottle	small	medium	large
Time taken for the bottle to be filled with 500 ml of detergent (seconds)	89	40	15

- (a) In which bottle did the detergent flow in the fastest? Explain your answer.

[1]

(b) Why did the size of the hole in the bottle affect the rate at which detergent flowed into the bottle? [2]

(c) Instead of making a bigger hole in bottle R, what can Sze Tong do so that the detergent can flow into the bottle faster? [1]



LEVEL : PRIMARY 4
SCHOOL : NANYANG PRIMARY SCHOOL
SUBJECT : SCIENCE
TERM : SA1

Q1	Q2	Q3	Q4	Q5	Q6	Q7	Q8	Q9	Q10
2	1	1	4	3	4	2	1	3	3
Q11	Q12	Q13	Q14	Q15	Q16	Q17	Q18	Q19	Q20
3	2	3	4	3	1	1	4	3	3
Q21	Q22	Q23	Q24	Q25	Q26	Q27	Q28	Q29	Q30
3	4	2	4	3	1	4	3	2	3

Q31a. The hamster in container B.

Q31b. The hamster needs air to live. The plastic container prevents air from entering the container, so it dies after a week.

Q31c. They both reproduce.

Q32a. It did not receive sunlight and could not make food.

Q32b. No, it reproduced by spores. Flowering plant reproduce by seeds.

Q32c. Bird's nest fern.

Q33a. i) Moist skin ii) Y: Hair

Q33b. The animals in group X reproduce by laying eggs while the animals in group Y reproduce by giving birth to young alive.

Q33c. Insects

Q33di) Animals M has 6 legs. ii) Animal M most likely is cold- blooded

Q34a. As the number of days increases, the amount of water left in the beaker decreases.

Q34b. The plant has roots and the roots absorb water for the plant.

Q34c. The roots of those plants are very strong so it could hold the plant firmly to the ground.

Q35a. The function of the digestive system is to break down food into simpler substances and absorb nutrients for the body to use.

Q35b. SEE PICTURE

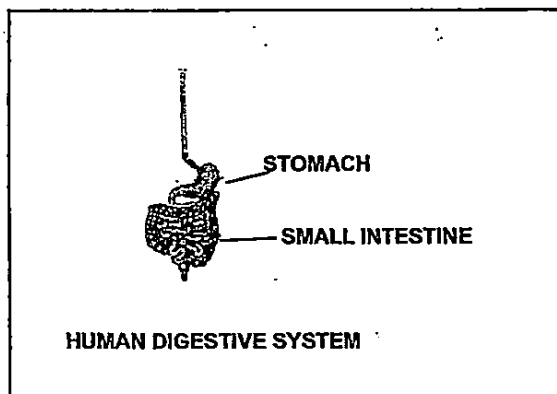

Q35c. It allows the food to move down the gullet easily.

Q36a. Sam had most likely stroked the iron nail more times in one direction.

Q36b. It would be pointing to the north-south direction.

Q36ci) Object S is a magnet. ii) All magnets will either attract or repel and object S attracted and repelled to magnet P.

Q37a) F

b) F

c) T

d) F

Q38. SEE PICTURE

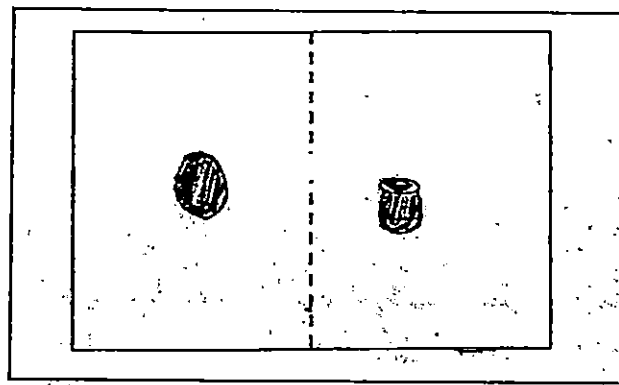

Q39a. The sun before 12 noon is not right above so the shadow formed would not be very short. At 12 noon, the sun is directly on top so the shadow formed would be very short.

Q39b. SEE PICTURE

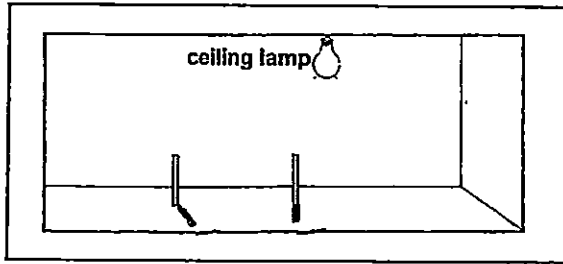

Q40.a. Q, P, R

Q40b. Alan could move closer towards the torchlight.

Q41a. i)4, ii)3, iii)1, iv) 2

Q41b. The rock occupies space.

Q42a. Gas.

Q42b. Gas can be compressed.

Q43a. SEE PICTURE

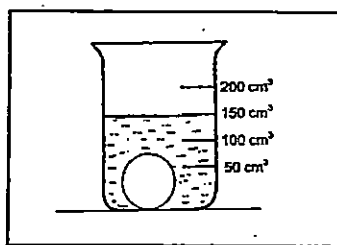

Q43b. Yes. The plasticine's volume would not change as plasticine is a solid and all solids have a definite volume.

Q44a. Bottle R. It took the shortest time to fill.

Q44b. When the size of the hole is larger, air could escape from the bottle faster. This will allow the detergent to flow in faster to occupy their space left behind.

Q44c. Sze Tong can remove the plasticine.

THE END