



NANYANG PRIMARY SCHOOL

PRIMARY 4 SCIENCE

SEMESTRAL ASSESSMENT 1
2014

BOOKLET A

Date : 8 May 2014
Duration : 1 h 45 min

Name : _____ ()

Class: Primary 4 ()

DO NOT OPEN THIS BOOKLET UNTIL YOU ARE TOLD TO DO SO.
FOLLOW ALL INSTRUCTIONS CAREFULLY.

Booklet A consists of 17 printed pages including this cover page.

Section A (30 x 2 marks = 60 marks)

For each question from 1 to 30, four options are given. One of them is the correct answer. Make your choice (1, 2, 3 or 4). Shade the correct oval (1, 2, 3 or 4) on the Optical Answer Sheet provided.

1. Which one of the following situations does **not** show that a living thing responds to changes in its surroundings?
- (1) A cat dies of old age
 - (2) A deer escapes when it spots a tiger.
 - (3) A frightened boy screams when he is attacked.
 - (4) A mimosa plant folds up its leaves when touched.
2. Which of the following explains why animals need to move about?
- A To look for food
 - B To look for shelter
 - C To escape from danger
- (1) A and B only
 - (2) A and C only
 - (3) B and C only
 - (4) A, B and C
3. Which one of the following correctly states the similarity and difference between a mushroom and a fern?

	Similarity	Difference
(1)	Both fern and mushroom have roots.	Fern has a cap and a stalk while mushroom does not.
(2)	Both fern and mushroom reproduce by seeds.	Fern grows on trees but mushroom does not.
(3)	Both fern and mushroom reproduce by spores.	Fern can make its own food while mushroom cannot.
(4)	Both fern and mushroom are living things.	Fern can respond to surrounding changes while mushroom cannot.

4. Which one of the following correctly states the similarities between plants and animals?

- (1) They make their own food.
- (2) They move about to get food.
- (3) They need air, food and water.
- (4) They give birth to their young alive.

5. Study the flow chart below.

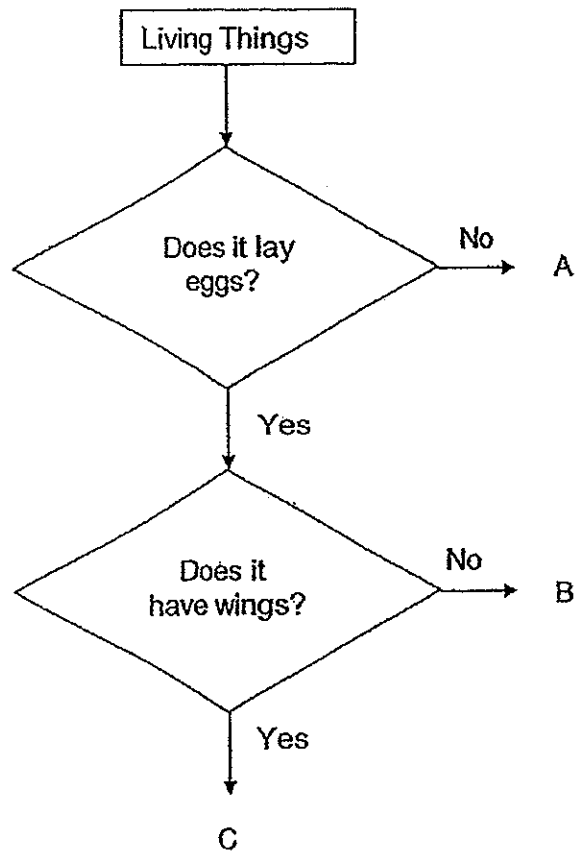

Which one of the following could represent A, B and C correctly?

	A	B	C
(1)	whale	butterfly	chicken
(2)	frog	whale	dragonfly
(3)	whale	frog	dragonfly
(4)	chicken	dragonfly	whale

Study the diagram below and answer questions 6 and 7.

The parts of a plant, W, X, Y and Z, are labelled as shown in the diagram below.

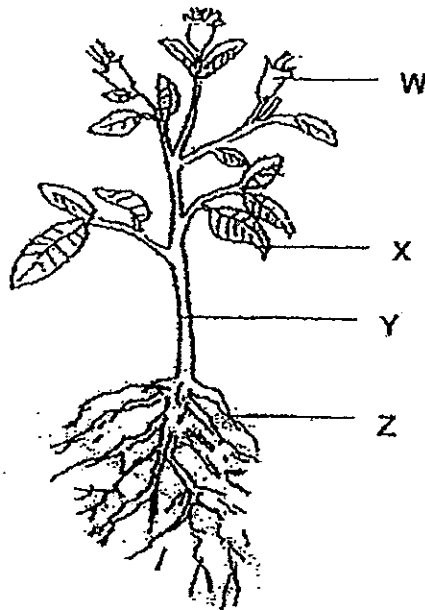

6. Which one of these parts allows the plant to make food?

- (1) W
- (2) X
- (3) Y
- (4) Z

7. Which one of the following correctly describes the functions of parts Y and Z correctly?

	Y	Z
(1)	To hold the plant upright	To hold the plant firmly to the ground
(2)	To hold the plant firmly to the ground	To carry water from Z to other parts of the plant
(3)	To carry water from X to other parts of the plant	To absorb water and mineral salts
(4)	To store food for its young	To provide food for us

8. Which of the following living things can make its own food?
- A Moss
 - B Toadstool
 - C Bread Mould
 - D Bird's Nest Fern
- (1) A and B only
 - (2) A and D only
 - (3) B and C only
 - (4) C and D only
9. Which of the following organs make up the human respiratory system?
- A Heart
 - B Nose
 - C Lungs
 - D Windpipe
- (1) A, B and C only
 - (2) A, C and D only
 - (3) B, C and D only
 - (4) A, B, C and D
10. Which one of the following actions does **not** require the use of joints in the skeletal system?
- (1) Riding a bicycle
 - (2) Blinking your eyes
 - (3) Running a marathon
 - (4) Bouncing a basketball

11. Study the diagram of the digestive system below carefully.

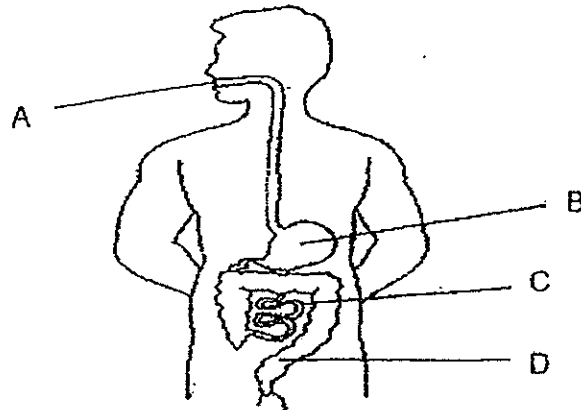

In which of the following parts of the human digestive system would digestion take place?

- (1) A, B and C only
- (2) A, B and D only
- (3) B, C and D only
- (4) A, B, C and D

12. Benedict ran round the school track for 20 minutes at the same speed. He used a device that measured his heartbeat every 5 minutes during his run. Which one of the following graphs best represents the change in Benedict's heartbeat during the run?

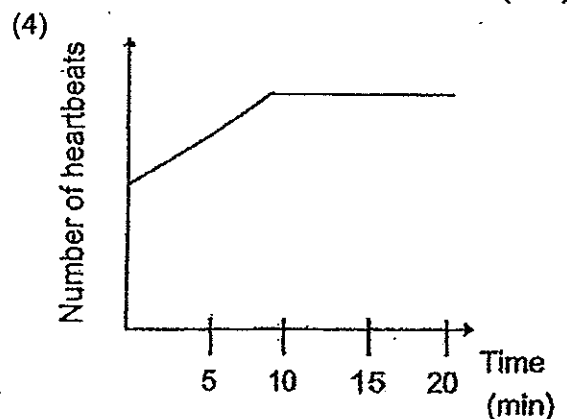
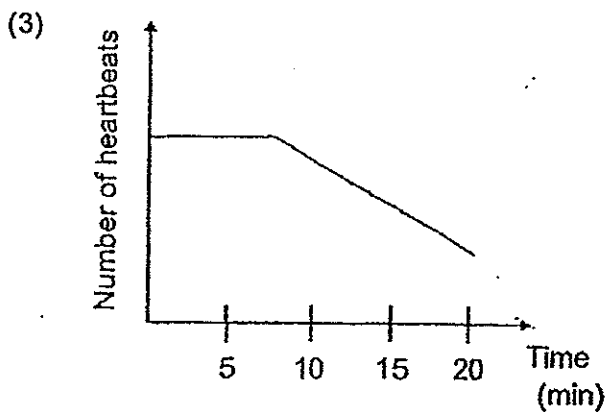
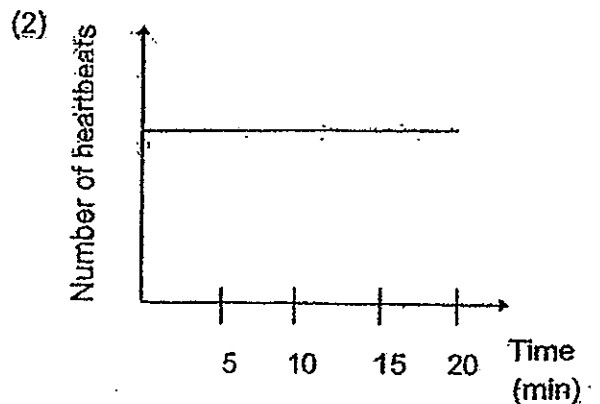
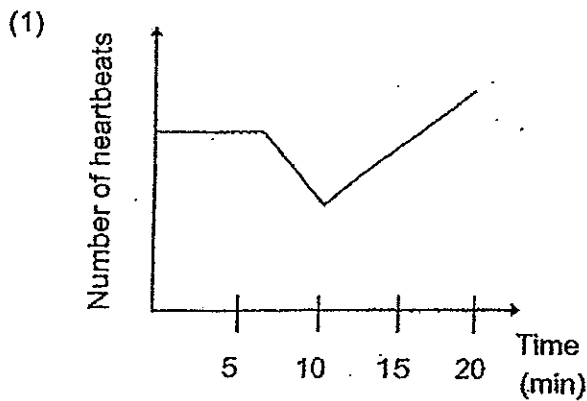

13. Wendy wanted to find out how the number of turns of a wire coiled around a nail will affect the strength of the electromagnet made. Which two setups should she use to make it a fair test?

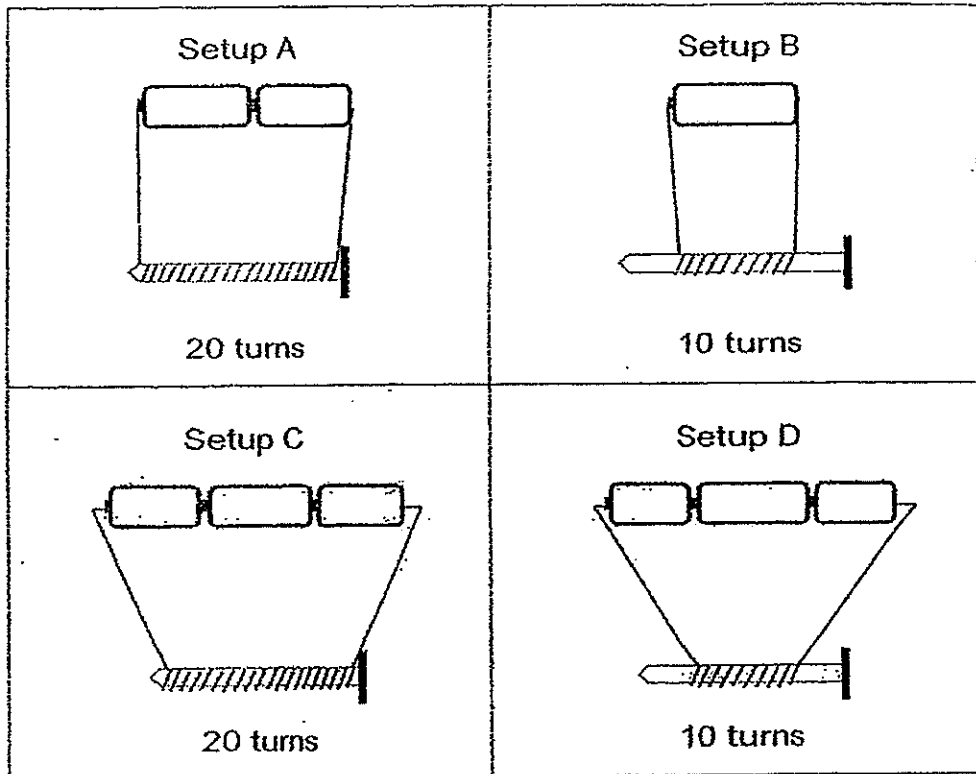

- (1) A and B
 (2) A and C
 (3) B and D
 (4) C and D

14. Mary set up seven magnets as shown in the diagram below.

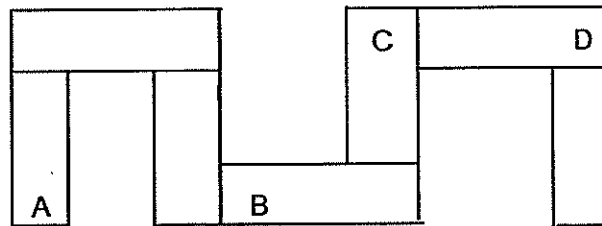

What could the poles of parts A B C and D be?

	A	B	C	D
(1)	South	North	North	South
(2)	North	South	North	South
(3)	South	South	North	North
(4)	North	North	South	North

15. Muthu drew up the classification table below during his Science lesson at school. Which one of the following pairs of light sources had been wrongly classified?

	Natural light source	Man-made light source
(1)	star	street lamp
(2)	sun	traffic light
(3)	ceiling light	lightning
(4)	fireflies	fireworks

16. Alex shone a light from a torch and placed 4 objects between the torch and tell wall. The objects were made of different materials but of the same thickness and size. Which one of the following materials will cast the darkest shadow on the wall?

- (1) wood
- (2) clear glass
- (3) frosted plastic
- (4) tracing paper

17. Light from a Jaser pointer was shone on a mirror. Which one of the following shows the correct path taken by the ray of light?

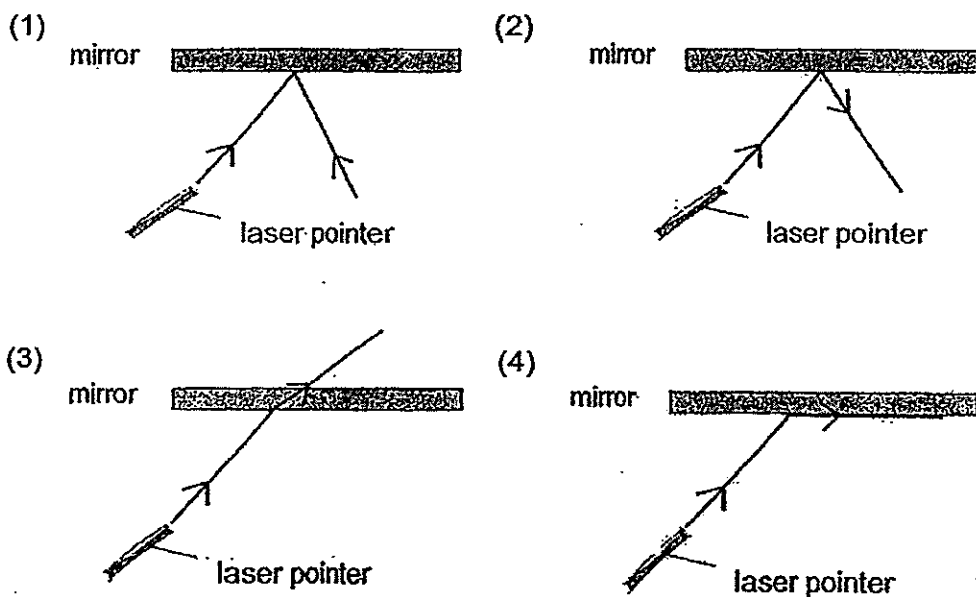

18. Chloe classified the following objects into the chart below.

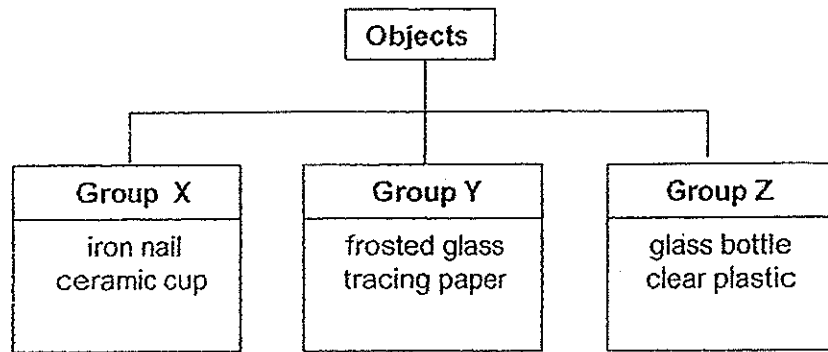

Which one of the following objects can be correctly classified into groups X, Y and Z??

	Group X	Group Y	Group Z
(1)	stapler	clear glass	aluminium foil
(2)	tissue paper	spectacle lens	stapler
(3)	clear glass	aluminium foil	cardboard
(4)	cardboard	tissue paper	spectacle lens

19. Which one of the following statements best explains why a shadow is formed?

- A Light can be reflected
- B Light is a form of energy
- C Light travels in straight lines
- D Light cannot pass through some objects.

- (1) A and B only
- (2) A and D only
- (3) B and C only
- (4) C and D only

20. Gareth shone a torch at the football and cast a shadow of the football on the screen as shown in the diagram below.

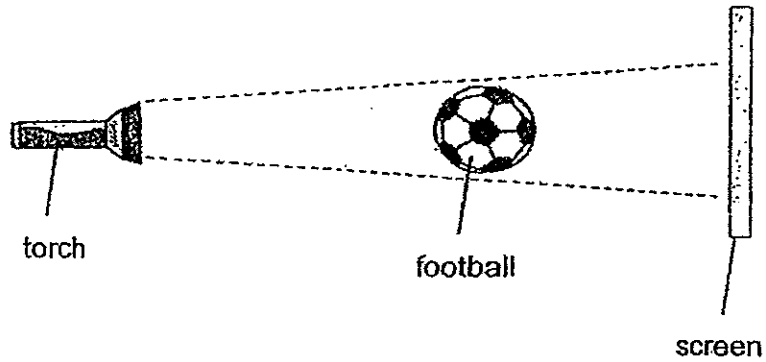

Which of the following actions could make the shadow of the football bigger?

- A. Move the football nearer to the torch.
 - B. Move the football nearer to the screen.
 - C. Move the screen further away from the ball.
 - D. Move the torch further away from the football.
-
- (1) A and B only
 - (2) A and C only
 - (3) B and D only
 - (4) C and D only

21. Dewi set up an experiment to study the formation of shadows. She placed a rectangular shoe box in front of a soft drink can.

Dewi shone the torch at the 2 objects as shown the diagram below. She observed that a shadow was cast on the screen.

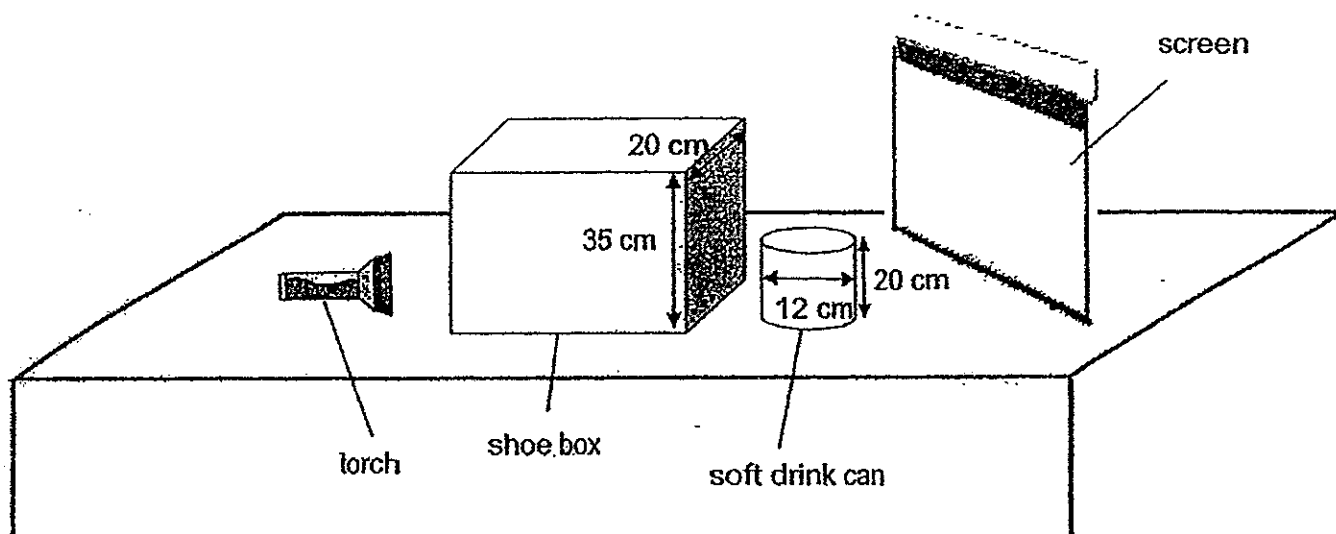

Which one of the following shadows would Dewi observe on the screen?

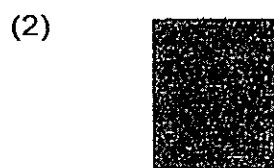

22. Jane started walking from position A towards a lighted street lamp which was at position B. She walked past the lighted street lamp to reach position C.

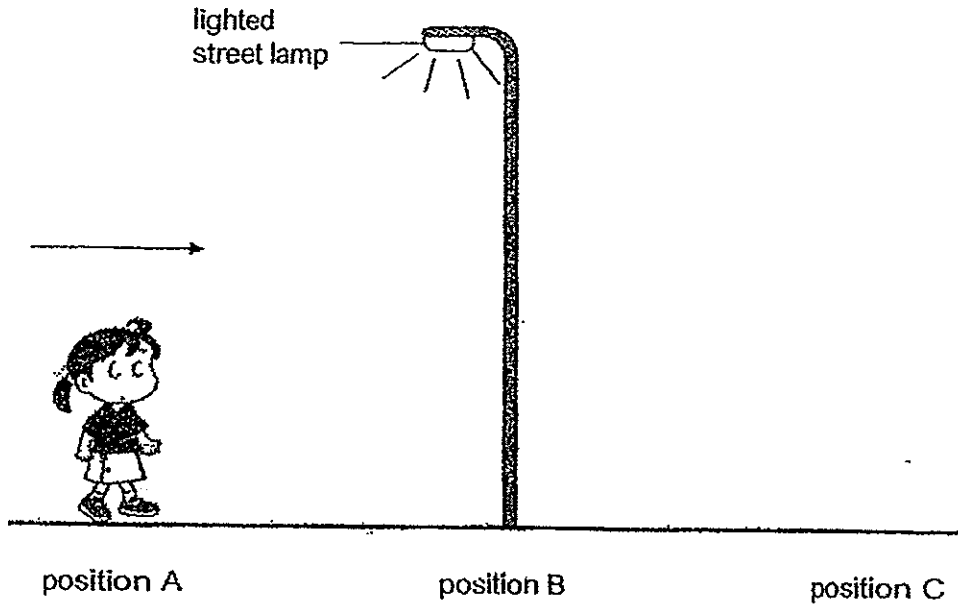

Which one of the following statements correctly describes Jane's shadow as she walked from position A to position C?

	At position A	At position B	At position C
(1)	Jane's shadow was in front of her	Jane's shadow was the longest	Jane's shadow was behind her
(2)	Jane's shadow was behind her	Jane's shadow was the shortest	Jane's shadow was in front of her
(3)	Jane's shadow was in front of her	Jane's shadow was the longest	Jane's shadow was in front of her
(4)	Jane's shadow was behind her	Jane's shadow was the shortest	Jane's shadow was behind her

23. Three pupils, Amy, Ben and Carlo were given an inflated balloon and each provided a reason to explain why the air inside the balloon is considered a matter.

Amy : Air occupies space in the balloon.
 Ben : Air takes the shape of the balloon
 Carlo : Air cannot be seen and has no smell.

Which of the pupils had provided a correct explanation?

- (1) Amy only (2) Ben only
 (3) Amy and Carlo only (4) Ben and Carlo only

24. Study the information shown below.

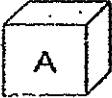
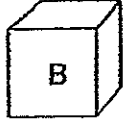
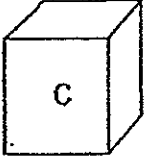
		
Mass: 320 g Volume: 90 cm ³	Mass: 300 g Volume: 120 cm ³	Mass: 280 g Volume: 200 cm ³

Based only on the information provided, which one of the following statements is wrong?

- (1) Cube A occupies less space than Cube B.
 (2) A smaller cube is always lighter than a bigger cube.
 (3) Cube B is heavier than Cube C but lighter than Cube A.
 (4) The volume of the cube increases when its size increases.

25. Li Ling filled a measuring cylinder with 20 ml of water. Then, she dropped pebble A into the measuring cylinder and recorded the new water level. Next, she dropped 3 other pebbles, B, C and D, of different sizes, one by one, into the water. The new water level was recorded after each pebble was dropped. No pebble was removed.

The diagram below shows the final reading when all 4 pebbles had been dropped inside the measuring cylinder.

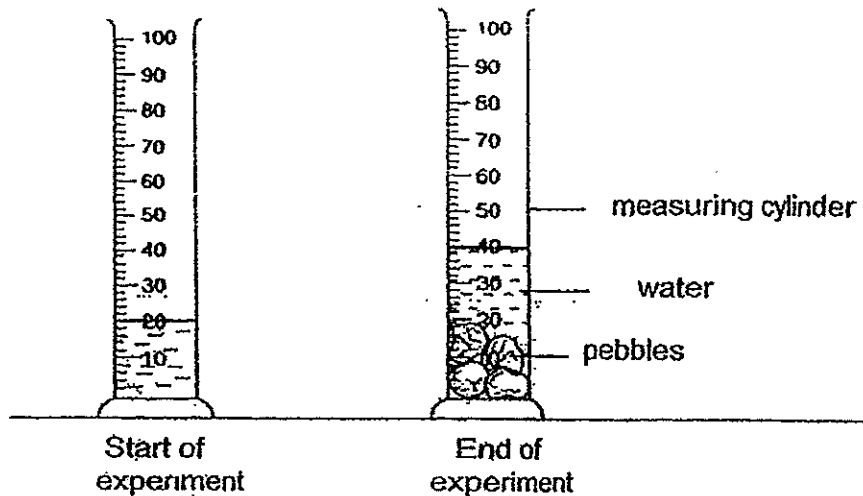

The table below shows the reading recorded when an additional pebble was dropped into the measuring cylinder.

Pebble added	Water level (ml)
A	22
A + B	28
A + B + C	32
A + B + C + D	40

Which one of the following correctly arranges the pebbles from the greatest volume to the smallest volume?

greatest volume → smallest volume

- (1) B, C, A, D
 (2) C, A, B, D
 (3) D, B, C, A
 (4) D, C, B, A

26. Study the flow chart below carefully.

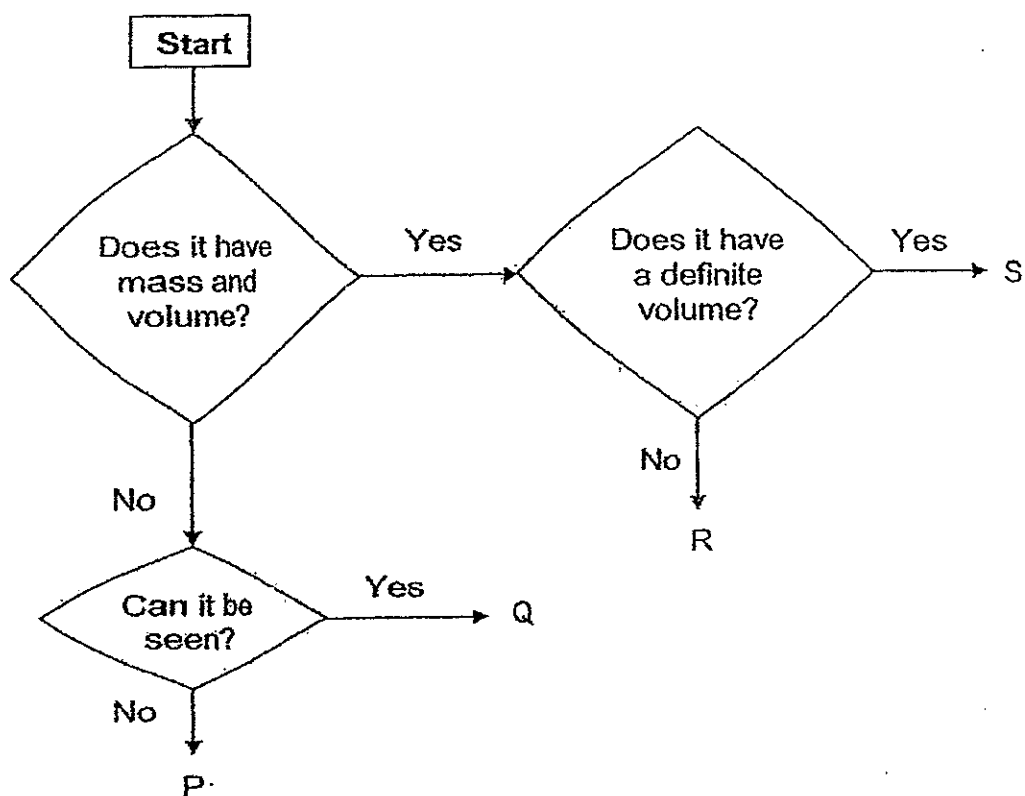

Based on the flowchart, which of the following statements are correct?

- A R is a gas.
- B S can only be a solid.
- C Q is a matter but P is not a matter.
- D R can be compressed but S cannot be compressed.

- (1) A and D only
- (3) A, C and D only

- (2) B and C only
- (4) A, B, C and D

27. Lily filled two beakers, A and B, with 100 cm^3 of oil each. She placed beaker A in a freezer and left beaker B near a window. After one day, both beakers were collected and immediately tilted sideways.

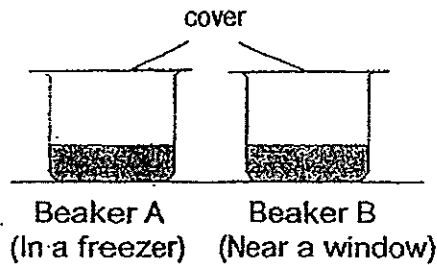

Which one of the following showed the correct water level of both beakers when they were tilted?

(1)

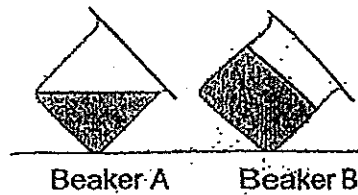

(2)

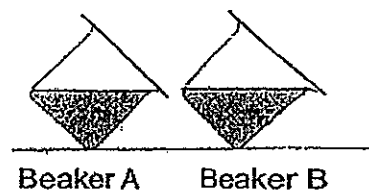

(3)

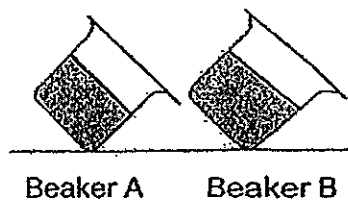

(4)

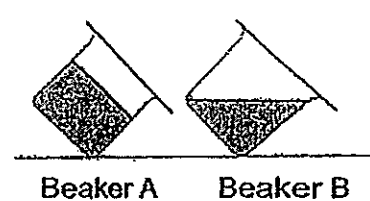

28. The diagram below shows 3 objects, X, Y and Z, on a lever balance.



Based only on the diagram, which one of the following statements can be concluded?

- (1) Objects X and Z have the same mass.
- (2) Objects Y and Z have the same mass.
- (3) Object Z has a smaller mass than object X.
- (4) Object Z has a greater mass than objects X and Y.

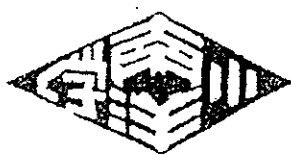

NANYANG PRIMARY SCHOOL

PRIMARY 4 SCIENCE

SEMESTRAL ASSESSMENT 1
2014

BOOKLET B

Date : 8 May 2014

Duration : 1 h 45 min

Name : _____ ()

Class: Primary 4 ()

Marks Scored:

Booklet A:		60
Booklet B :		40
Total		100

Any query on marks awarded should be raised by 20 May 2014. We seek your understanding in this matter as any delay in the confirmation of marks will lead to delays in the generation of results.

Parent's signature:

DO NOT OPEN THIS BOOKLET UNTIL YOU ARE TOLD TO DO SO.
FOLLOW ALL INSTRUCTIONS CAREFULLY.

Booklet B consists of 14 printed pages including this cover page.

29. Study the classification chart shown below.

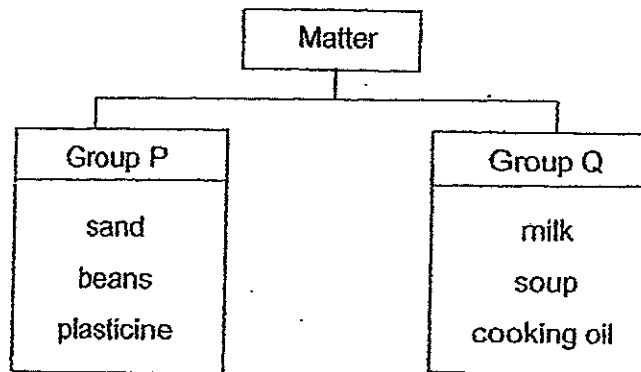

How are the objects in Group P similar to those in Group Q?

- A They have mass.
- B They have a definite volume.
- C They cannot be compressed.
- D They take up the shape of the container they are in.

- (1) A and B only
- (2) B and D only
- (3) A, B and C only
- (4) A, C and D only

30. Beth had 2 containers, X and Y, of the same mass. She filled container X to the brim with water, as shown in the diagram below. Next, she poured all the water in container X into container Y.

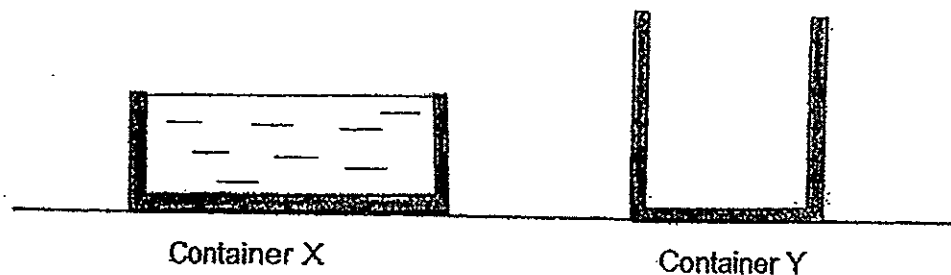

If no water was spilled, which one of the following observations would she not make?

- (1) The water level and the shape of water changed.
- (2) The volume of water and the shape of water changed.
- (3) The mass of water and the volume of water remained unchanged.
- (4) The mass of water remained unchanged but the shape of water changed.

Section B (40 marks)

Write your answers to questions 31 to 44 in the spaces provided.

31. Two living plants and one plastic plant were placed into 3 identical containers filled with 200ml of water. A layer of oil was poured into each container to prevent any water loss to the environment.

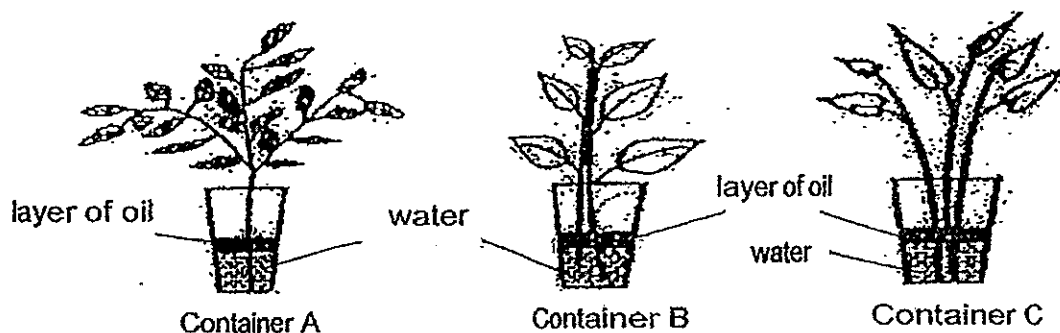

The volume of water in each container was measured on the 7th day and recorded in the table below.

Container	Volume of water (ml)	
	Day 1	Day 7
A	200	180
B	200	175
C	200	200

- (a) Which one of the containers, A, B or C, most likely contained a plastic plant? [1]

Container _____

- (b) Explain why the amount of water in containers A and B decreased in Day 7. [1]

- (c) Besides water, state 2 other conditions that the two living plants need in order to grow well. [1]

(i) _____

(ii) _____

32. The table below shows four groups of animals, A, B, C and D, and their characteristics.

Animal Group			
A	B	C	D
<ul style="list-style-type: none">• Has 3 body parts	<ul style="list-style-type: none">• Has scales	<ul style="list-style-type: none">• Has hair	<ul style="list-style-type: none">• Has beak
<ul style="list-style-type: none">• Lays eggs	<ul style="list-style-type: none">• Has gills	<ul style="list-style-type: none">• Gives birth to young alive	<ul style="list-style-type: none">• Has feathers
<ul style="list-style-type: none">• Has a pair of feelers	<ul style="list-style-type: none">• Most lay eggs	<ul style="list-style-type: none">• Produces milk	<ul style="list-style-type: none">• Lays eggs

- (a) Based only on the information above, identify the animal group.

[2]

A: _____

B: _____

C: _____

D: _____

- (b) Give an example of an animal that can be placed under group C.

[1]

- (c) State another characteristic of animals that belong in group A.

[1]

33. The table below lists the characteristics of four different living things, A, B, C and D. A tick (✓) in each box indicates the characteristics that are present in the living thing.

Characteristic of living thing	Living things			
	A	B	C	D
Has seeds			✓	
Have fins to help it move		✓		
Has 6 legs				✓
Can move about from place to place		✓		✓
Reproduce by spores	✓			

- (a) Classify the four living things in the chart below by writing A, B, C and D in the correct boxes. [2]

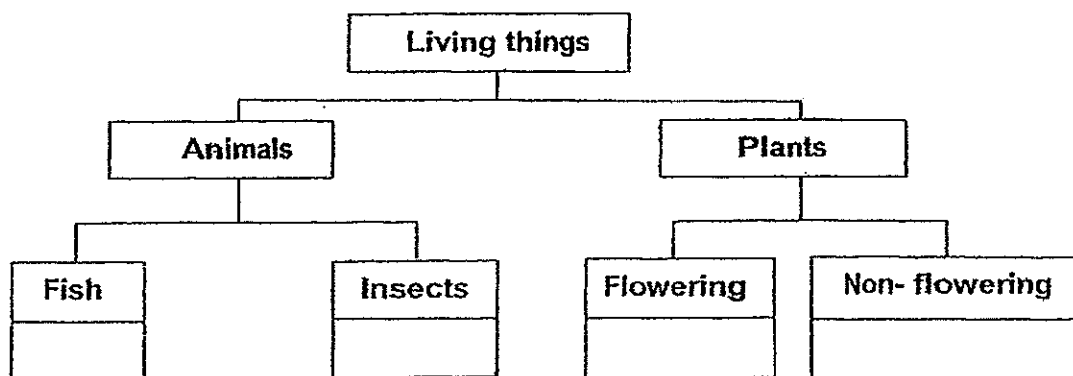

- (b) Study animal X below.

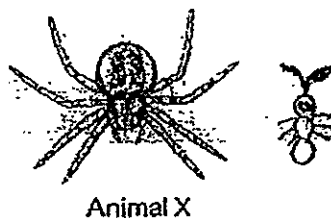

John classified animal X as an insect. State two characteristics of the animal shown above to explain why he was wrong. [2]

- (i) _____

- (ii) _____



34. Study the diagram below. W and X represent parts of the plant.

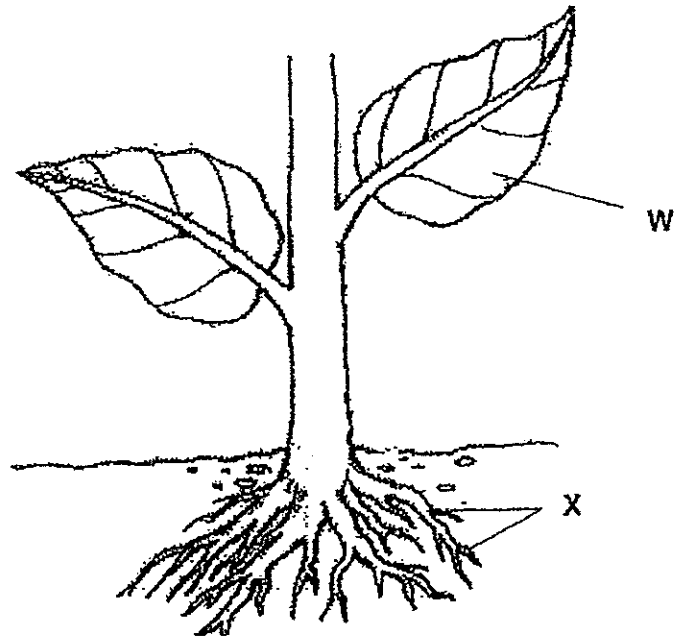

(a) Give an example of a plant that can store food in part X. [1]

(b) If all the part W in the plant above are removed, what would happen to the plant after 2 weeks? Explain your answer. [2]

35. The diagram below shows the human digestive system.

(a) In the boxes provided, identify parts of the digestive system.

[2]

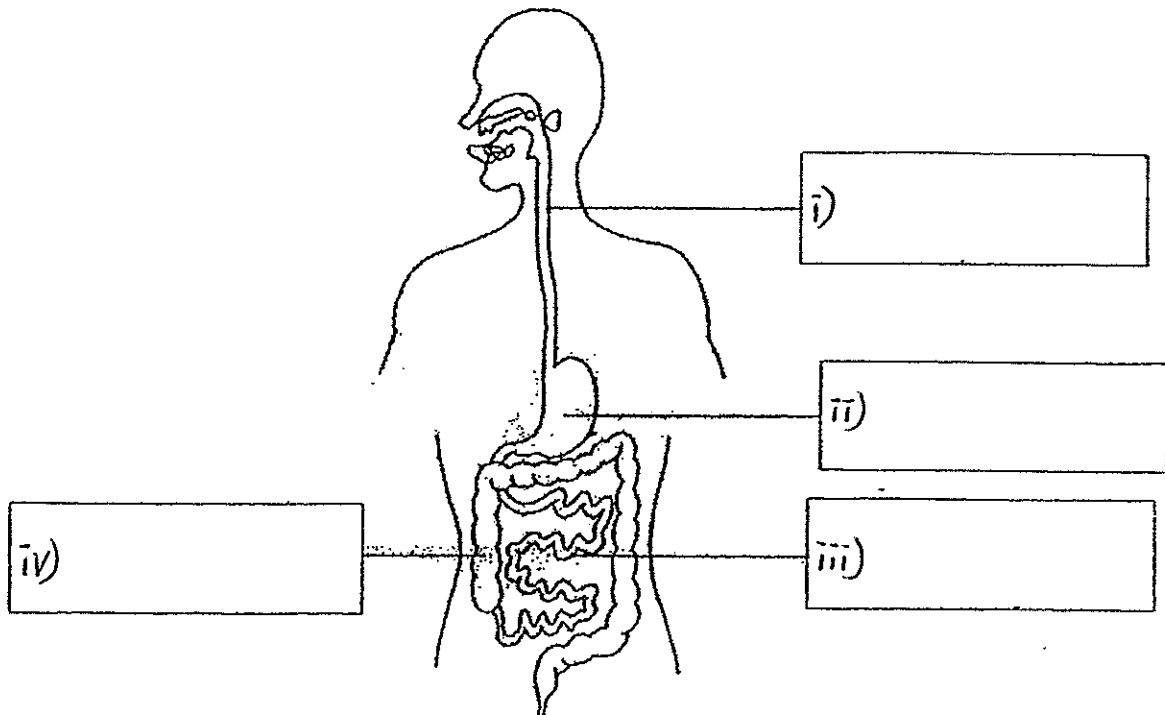

Sally often gobbles her food. Her mother always reminds her to chew her food well before swallowing.

(b) What is the purpose of chewing?

[1]

36. Sammy had three iron bars, P, Q and R. Two of the iron bars were magnetised. She labelled the ends of the bars as shown in the diagrams below.

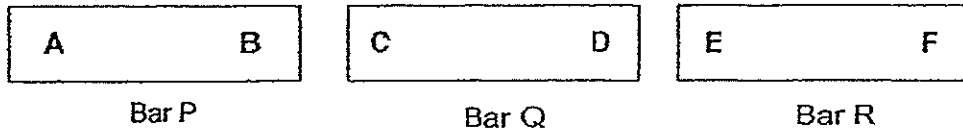

She brought the ends of the iron bars close to each other to observe the effect. The results were shown in the table below.

Ends that were brought close to each other	Observations
A and C	Attract
B and D	Attract
A and E	Repel
C and F	Attract
A and D	Attract

- (a) Based on the results above, which one of the iron bar is **not** a magnet? [1]

Bar _____

- (b) Explain how a non-magnetised iron bar could be turned into a magnet using another magnet? [1]

- (c) Sammy did something to one of the magnets and it could not attract a steel paper clip anymore. Suggest what could have been done to the magnet. [1]

37. One sunny afternoon, David conducted an experiment to find out if light is needed for him to see things. David painted the inside of a shoebox with black paint and sealed it up with glue. Next, he cut a hole (hole A) on top of the sealed shoebox and another smaller hole (hole B) on one of its side. Then, he put a stone into the shoebox through hole A, as shown in the diagram below.

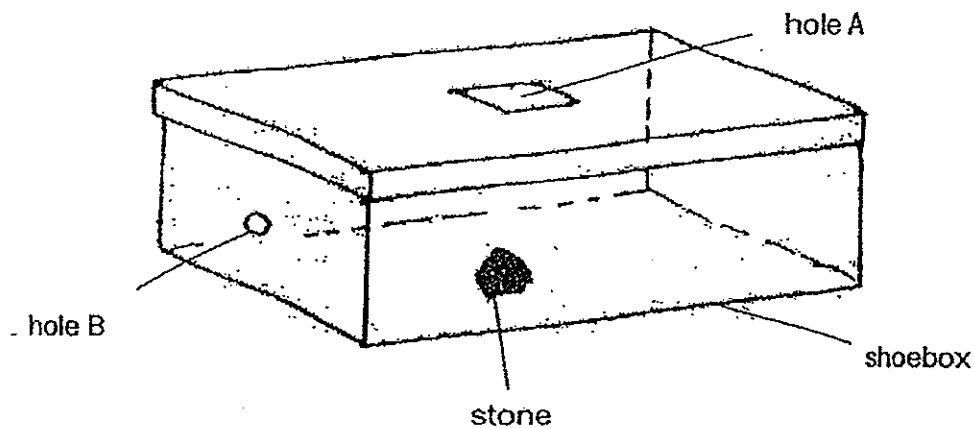

- (a) David then covered hole A with a piece of thick cardboard and looked through hole B. He realised that he could not see anything in the box. Explain why. [1]

- (b) What can he conclude from his experiment? [1]

- (c) Which property of light enables him to see both the stone and the box? [1]

38. The diagram below shows the top view of a corridor. Mary is standing at the position marked A.

With the help of three mirrors, Mary could see the star at the end of the tunnel.

With a pencil and ruler, draw arrows to show the path of light that makes it possible for Mary to see the star at the end of the tunnel.

[2]

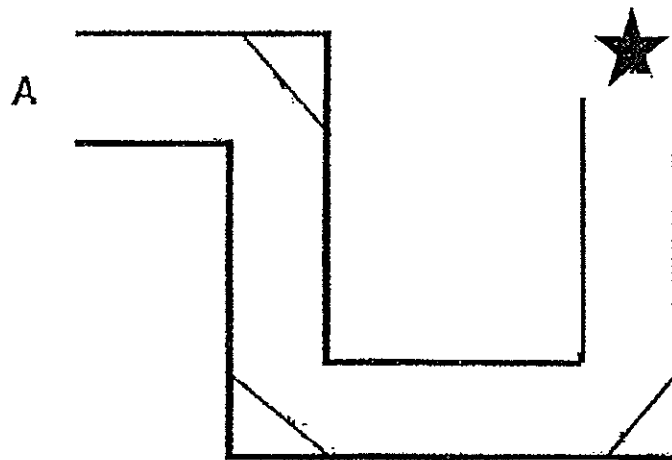

39. The graph below shows the amount of light which passes through materials A, B, C and D.

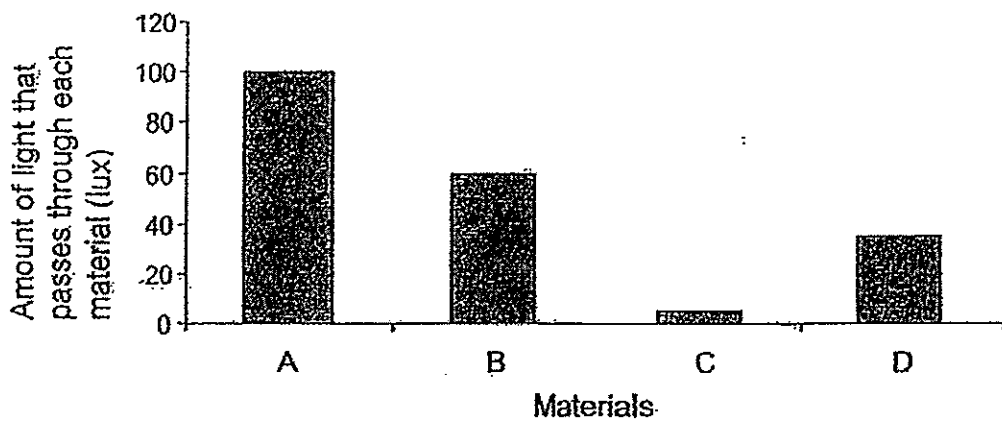

Which material should Mr. Tan choose for his bedroom curtains if he wants his room to be as dark as possible during the day? Explain your answer.

[2]

40. Farmer Wong placed a pole in his farm and observed the shadow of the pole formed on the ground at different times of the day as shown in the diagram below.

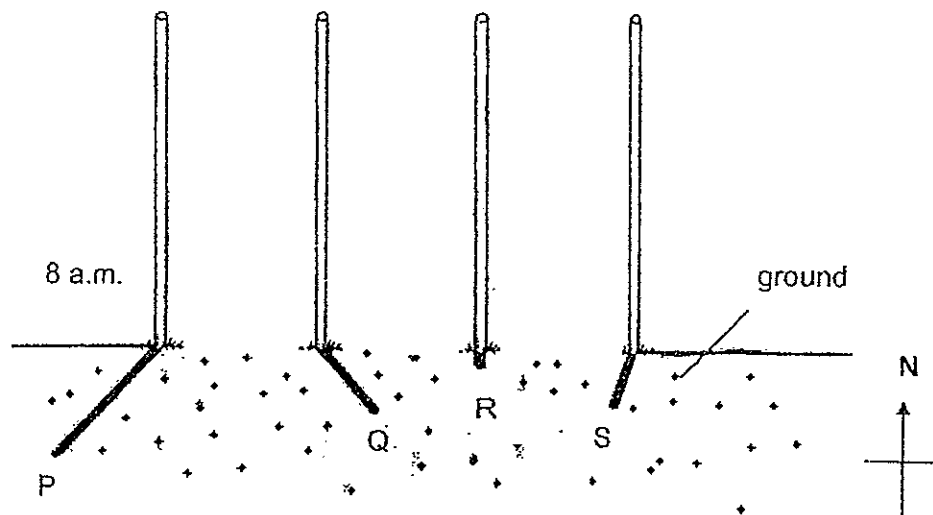

- (a) If shadow P was observed at 8 a.m, fill in the table below to identify the shadows that would be observed at 10.30 a.m and 12 noon. [1]

Time	Shadow
8 a.m.	P
10.30 a.m.	
12 noon	

- (b) On the diagram below, **draw the shadow** of the pole that was observed on the ground by Farmer Wong at 4 p.m. [1]

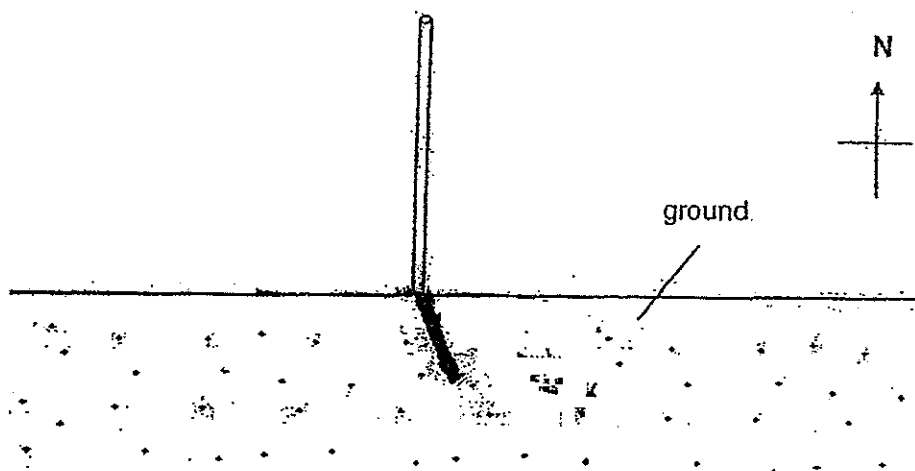

41. Miss Wang had a container with a capacity of 50 cm^3 . She fitted a pump into the container. Each time she pushed the pump, 50 cm^3 of air would enter the container. Miss Wang pushed the pump 3 times.

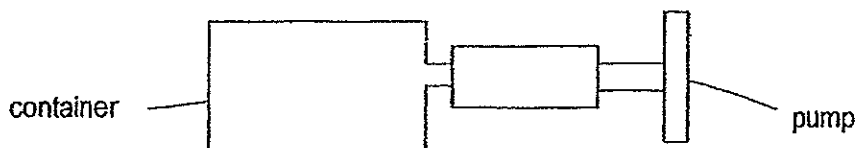

Miss Wang's pupils, Ben and Jerry, each drew a line graph to show the amount of air in the container based on the experiment above.

Ben's Line Graph

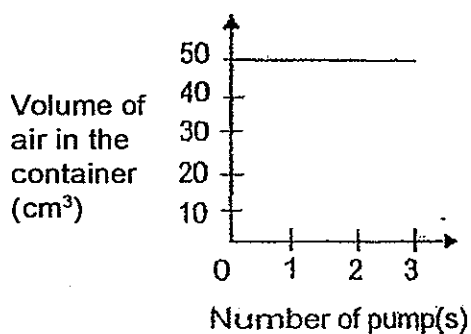

Jerry's Line Graph

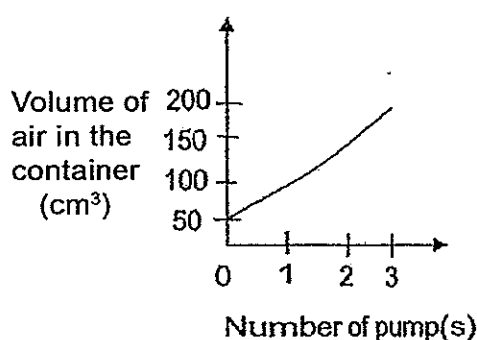

- (a) Which pupil had drawn the correct graph? Explain your answer.

[1]

Using the same set of apparatus, Miss Wang filled the container with 50 cm^3 of sand. She tried to push the pump and observed that she was only able to push the pump in slightly.

- (b) Since sand is a solid that cannot be compressed, explain Miss Wang's observation.

[1]

42. Devi prepared two set-ups, as shown in the diagrams below.

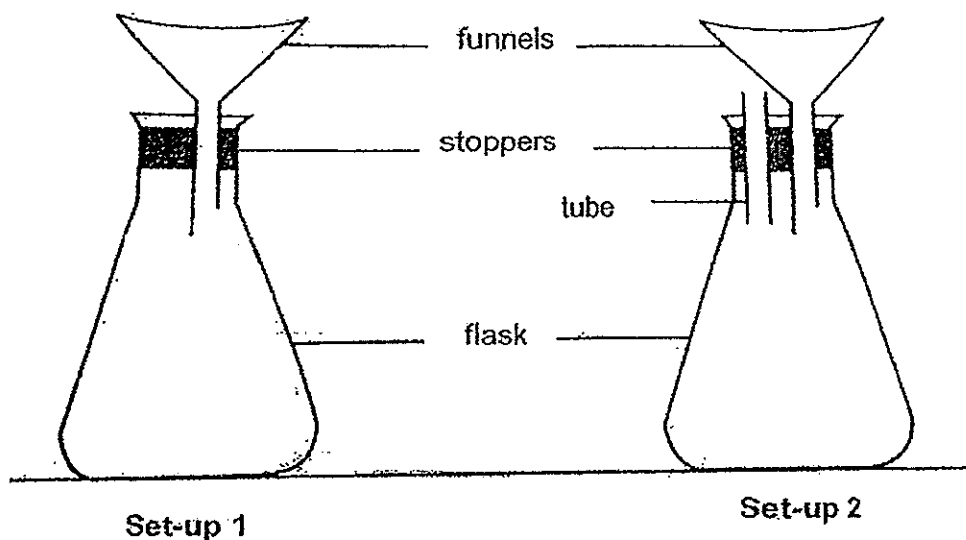

- (a) She poured water into the funnels of both set-ups and observed that set-up 2 allowed water to flow into the conical flask more quickly than set-up 1. Explain Devi's observation. [1]

- (b) Devi wanted the water to flow into the conical flask even faster in set-up 2. What change(s) should she make to set-up 2 in order to do so?

Tick the appropriate box (es) to indicate the change(s) needed. [1]

	Change made to set-up 2	Tick
i.	Use more tubes.	<input type="checkbox"/>
ii.	Use a longer tube.	<input type="checkbox"/>
iii.	Use a narrower tube.	<input type="checkbox"/>

43. Ramly wanted to find out the volume of a stone. He prepared the following set-up, as shown in the diagram below. He had to pour some water into the displacement can before lowering the stone into it.

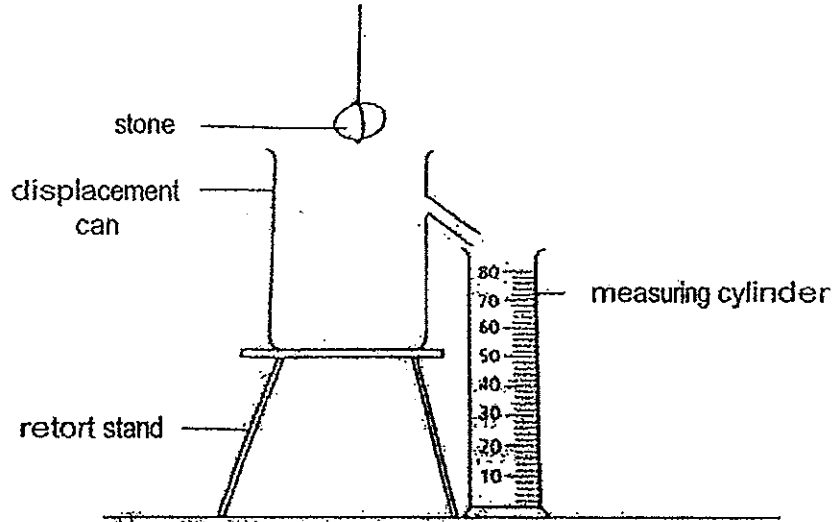

- (a) In the diagram above, draw the water level in the displacement can to show the amount of water needed. [1]
- (b) In the table below, write down steps 2 and 3 that Ramly would take to find the volume of the stone after filling the can with water. The first word in steps 2 and 3 have been provided. [2]

Step 1	Fill the displacement can with the correct amount of water.
Step 2	Lower _____ _____ _____
Step 3	Record _____ _____ _____

44. Zhao Rong fixed one end of a deflated balloon tightly to a straw using a rubber band. He then taped the other end of the balloon to the bottom of a basin which was filled with water. After he had marked the water level, he blew air into the straw, as shown in the diagram below.

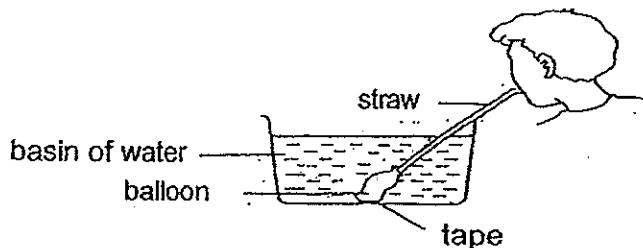

- (a) State one observation that Zhao Rong would make about the water level in the basin when air was blown into the straw. Explain your answer [2]

Zhao Rong attached another balloon over the mouth of an empty plastic bottle, as shown in the diagram below.

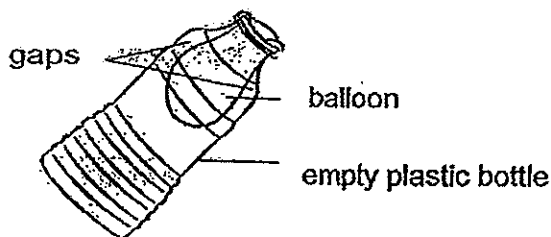

- (b)(i) He tried to blow air into the balloon but realized that it would not inflate. Give an explanation for his observation. [1]

- (b)(ii) Without removing the balloon from the mouth of the bottle, state a change that Zhao Rong could make to the bottle so that the balloon would be able to inflate when air was blown into it. [1]

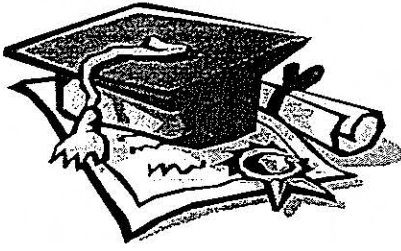

ANSWER SHEET

EXAM PAPER 2014
SCHOOL : NANYANG
PRIMARY : P4
SUBJECT : SCIENCE
TERM : SA1

Q1	Q2	Q3	Q4	Q5	Q6	Q7	Q8	Q9	Q10	Q11	Q12	Q13	Q14	Q15	Q16	Q17
1	4	3	3	3	2	/1	2	3	2	1	4	4	3	3	1	2

Q18	Q19	Q20	Q21	Q22	Q23	Q24	Q25	Q26	Q27	Q28	Q29	Q30
4	4	2	2	2	1	2	3	1	4	4	3	2

31)a)C.

b)Plants and water, the roots of the plant in containers A and B absorbs water for the plant. Thus, the amount of water in containers A and B decreased on Day 7.

c)i)Air ii)sunlight.

32)a)A: Insects B: Fish C: Mammals D: Birds

b)Monkey.

c)The animals that belong in group A has 3 pairs of legs.

33)a)B, D, C, A

b)i)Insects have 6 legs but animal X has have 8 legs.

ii)Insects have 3 body parts but animal X have 2 body parts.

34)a)Carrot-plant.

b)The plant will die. Plants need food to survive, part W makes food for the plant, if all the part W in the plant are removed , the plant will not be able to make any more food and it with die.

35)a)i)Gullet ii)Stomach iii)small intestine iv)large intestine
b)Chewing helps to break the food into smaller pieces so that digestion will be easier as there will be more exposed surface area for the digestive juice to work on.

36)a)Q.
b)Stroke the iron bar with one pole of magnet in one direction several times.
c)The magnet could have been heated.

37)a)There is no light in the shoe box and the stone is not a light source. Thus, David will not be able to see anything as the stone will no be able to reflect any light into David's eyes.
b)David can conclude that light is needed for David to see things.
c)Light can be reflected.

38)

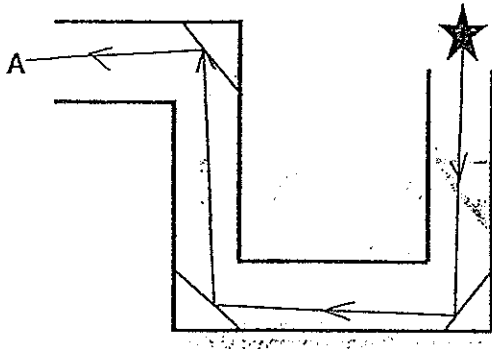

39)Material C. Among all the material, material C allows the least light D pass through, thus, it is the most suitable to be made as a bedroom curtain to let Mr Tap's room be as dark as possible during the day.

40)a)S, R
b)

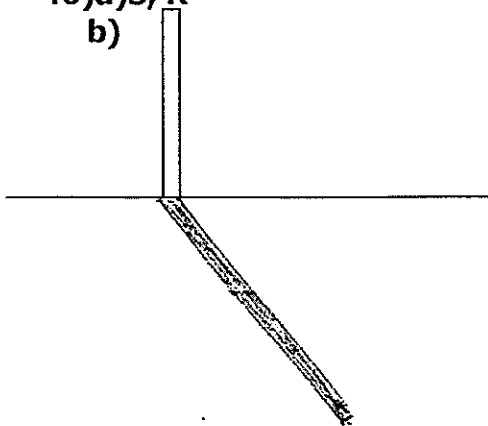

41)a)Pen. Air can be compressed. Thus, no matter how many number of pumps are pumped in, the volume of the air the container will always be the same.

b)There is same air particles between the sand. Since air can be compressed, some air is able to enter.

42)a)There is a tube in set-up 2, allowing air to escape from the tube and water to flow from the funnel into the flask, taking up the space which air had escaped while air is trapped in set-up 1, so water flows faster into set-up 2 than set-up 1.

b)i)

43)a)

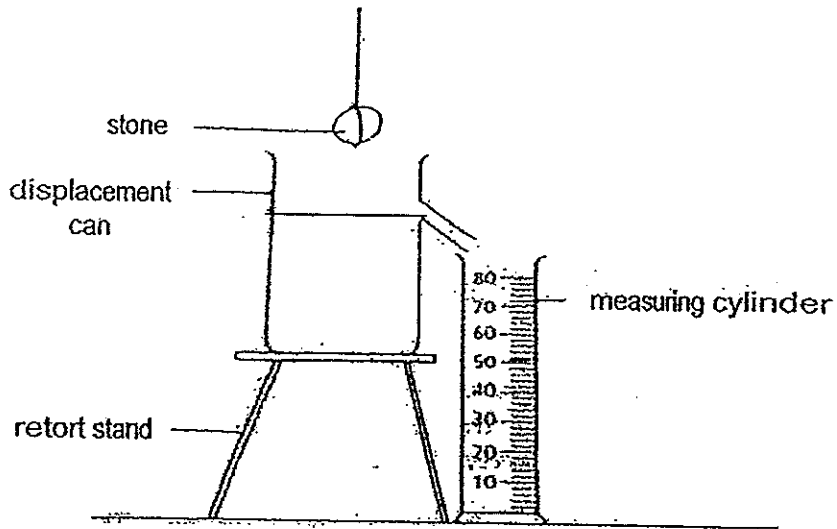

b)2)Lower the stone into the water completely and water will flow into the measuring cylinder.

3)Record the amount of water in the measuring cylinder and that is the volume of the stone.

44)a)Water level in the basin will increase. Air in the balloon take up more space in the balloon, making the balloon inflated and the water level to rise.

b)i)There is air in the empty plastic bottle and air takes up space. Thus, the balloon will not be able to be inflated.

ii)Zhao Rong could some holes in the bottle.

