

2

METHODIST GIRLS' SCHOOL (PRIMARY)  
Founded in 1887



MID-YEAR EXAMINATION 2016  
PRIMARY 4  
MATHEMATICS

(BOOKLET A)

Total Time

Sections A to C: 1 hour 45 minutes

INSTRUCTIONS TO CANDIDATES

Do not turn over this page until you are told to do so.  
Follow all instructions carefully.  
Answer all questions.

Name: \_\_\_\_\_ ( )

Class: Primary 4. \_\_\_\_\_

Date: 10 May 2016

This booklet consists of 7 printed pages including this page.

**Section A: MCQ (36 marks)**

Questions 1 to 18 carry 2 marks each. For each question, four options are given. One of them is the correct answer. Make your choice (1, 2, 3 or 4). Shade the correct oval (1, 2, 3 or 4) on the Optical Answer Sheet.

1. Eighty-four thousand and five hundred and six written in figures is \_\_\_\_\_.

(1) 84 560  
(2) 84 506  
(3) 84 056  
(4) 8 456

2. 53 thousands and 60 tens is the same as \_\_\_\_\_.

(1) 5 360  
(2) 53 060  
(3) 53 600  
(4) 53 610

3. Look at the number pattern below.

65 234, 64 344, 63 454, \_\_\_\_\_, 61 674.

What is the missing number?

(1) 62 344  
(2) 62 564  
(3) 63 444  
(4) 64 564

4. I think of a number. It is a multiple of 6. When it is divided by 7, it has a remainder of 6. What is the number?

(1) 13  
(2) 42  
(3) 48  
(4) 60

5. Which one of the following is the first common multiple of both 6 and 9?

(1) 3  
(2) 18  
(3) 36  
(4) 54

6. Which of the following pair of numbers has 7 as a common factor?
- (1) 1 and 7
  - (2) 14 and 37
  - (3) 36 and 42
  - (4) 42 and 56
7. Emily had 653 stamps. When she arranged them equally onto 9 pages of an album, there were some stamps left. How many stamps were there on each page of the album?
- (1) 5 877
  - (2) 644
  - (3) 72
  - (4) 5
8. A number when rounded off to the nearest hundred gives 15 700. What is the smallest possible number?
- (1) 15 720
  - (2) 15 701
  - (3) 15 685
  - (4) 15 645
9. The table below shows the number of girls from 4 classes who are in the Fitness Club.

Class	Number of pupils
Primary 4 A	15
Primary 4 B	23
Primary 4 C	28
Primary 4 D	

Mr Lim accidentally spilled some ink on his paper. However, he remembered that the number of girls from Primary 4 D is three times that of the number of girls in Primary 4 A.  
How many girls are there in the Fitness Club altogether?

- (1) 111
- (2) 71
- (3) 66
- (4) 45

10. In the figure, which one of the following is an obtuse angle?

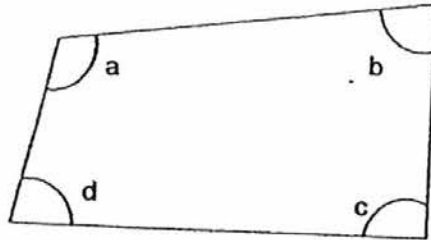

- (1)  $\angle a$   
(2)  $\angle b$   
(3)  $\angle c$   
(4)  $\angle d$
11. Which one of the following shows a turn between  $\frac{1}{2}$  and  $\frac{3}{4}$ ?

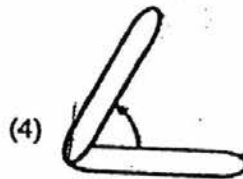
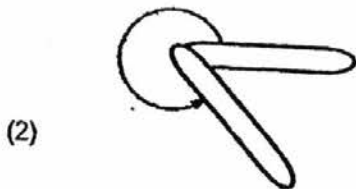
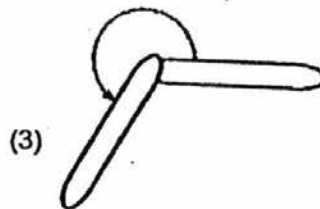
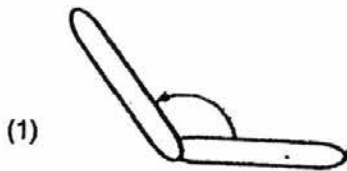

12. Find the product of 680 and 38.

- (1) 25 878  
(2) 25 840  
(3) 7 480  
(4) 2 584

13.

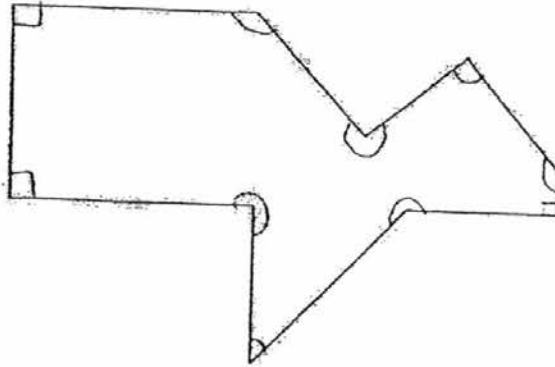

Look at the figure above. How many right angles are there **inside** the figure?

- (1) 5
- (2) 6
- (3) 3
- (4) 4

14. The following grid shows the position of 6 boys standing in the school field. Who is standing **North-west** of Tom?

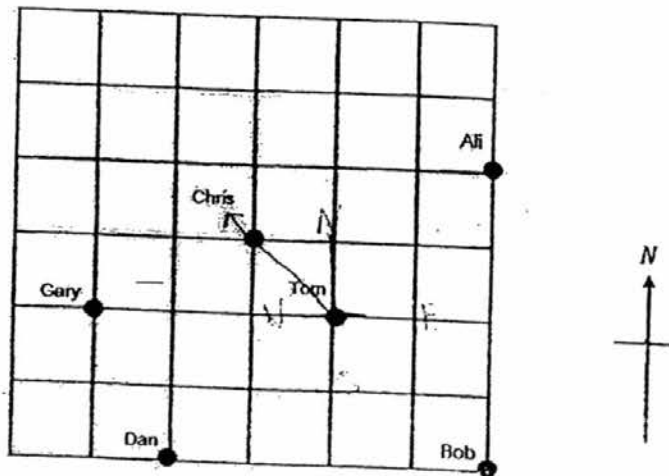

- (1) Ali
- (2) Chris
- (3) Gary
- (4) Dan

15. Riduan bought 24 boxes of oranges. There were 15 oranges in each box. 40 were rotten. He repacked them into trays of 4. How many trays are there altogether now?

- (1) 360
- (2) 320
- (3) 100
- (4) 80

16. Which one of the following figures has more than one line of symmetry?

(1)

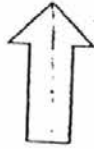

(2)

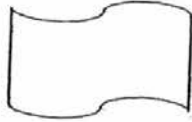

(3)

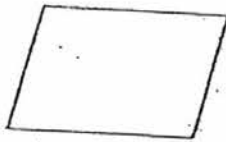

(4)

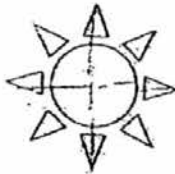

17. The graph below shows the number of participants in a reading programme at the National Library in the first 6 months.

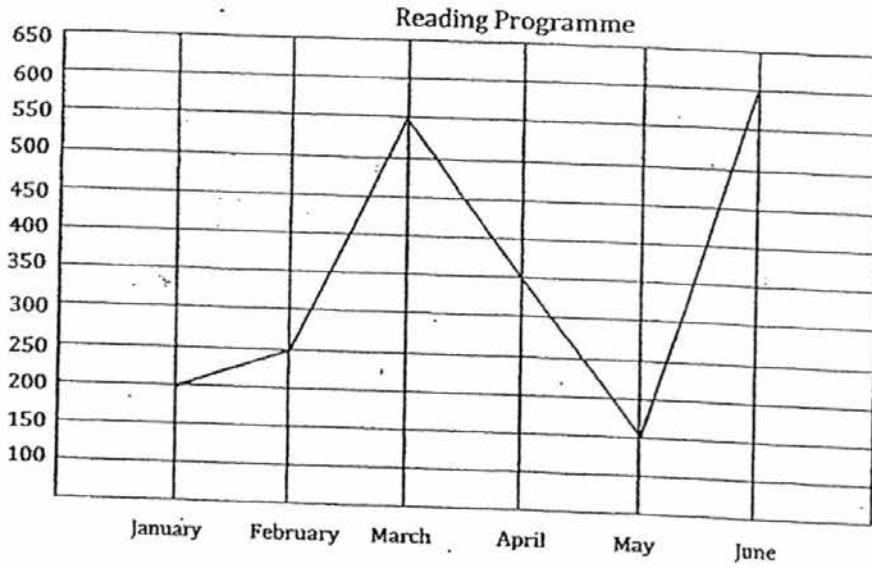

Which period was there the greatest increase in the number of participants?

- (1) January to February
  - (2) February to March
  - (3) March to May
  - (4) May to June
18. Andrew wants to buy the same type of notebooks. If he buys 10 notebooks, he will be short of \$6. If he buys 9 notebooks, he will have \$2 left. How much does Andrew have?
- (1) \$54
  - (2) \$56
  - (3) \$72
  - (4) \$74

End of Booklet A





METHODIST GIRLS' SCHOOL (PRIMARY)

Founded in 1887



MID-YEAR EXAMINATION 2016  
PRIMARY 4  
MATHEMATICS

(BOOKLET B)

Total Time

Sections A to C: 1 hour 45 minutes

INSTRUCTIONS TO CANDIDATES

Do not turn over this page until you are told to do so.  
Follow all instructions carefully.  
Answer all questions.

Name: \_\_\_\_\_ ( )

Class: Primary 4. \_\_\_\_\_

Date: 10 May 2016

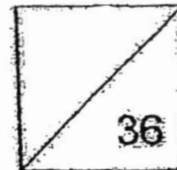

This booklet consists of 8 printed pages including this page.

**Section B: (36 marks)**

Questions 19 to 36 carry 2 marks each.

Write out the correct answers for the following questions in the space provided. Show your working clearly and give your answers in the units provided.

19. Write 59 248 in words.

---

20. Use the digits below to form the smallest 5-digit ~~odd~~ number with 4 in the hundreds place.

3	6	0	1	4
---	---	---	---	---

Ans: \_\_\_\_\_

21. Find the sum of the first two common multiples of 3 and 4.

Ans: \_\_\_\_\_

22. What is the quotient when 2407 is divided by 7?

Ans: \_\_\_\_\_

23. Some factors of 36 are 1, 2, 4 and 9. What are the other remaining factors of 36?

Ans: \_\_\_\_\_

24. One carton contains 3 litres of milk. Pearlyn needs 25 litres of milk for her party. What is the least number of cartons she needs to buy?

Ans: \_\_\_\_\_

25. A squash racket costs 3 times as much as a pair of sports shoes. A squash racket and 6 pairs of sports shoes cost \$765. How much does a pair of sports shoes cost?

Ans: \$ \_\_\_\_\_

26. Mrs Lim gave 12 stickers each to 37 students. How many stickers did she give away? Round off your answer to the nearest tens.

Ans: \_\_\_\_\_

27. The figure below shows a **square** and 2 **identical** rectangles. Find the perimeter of the figure.

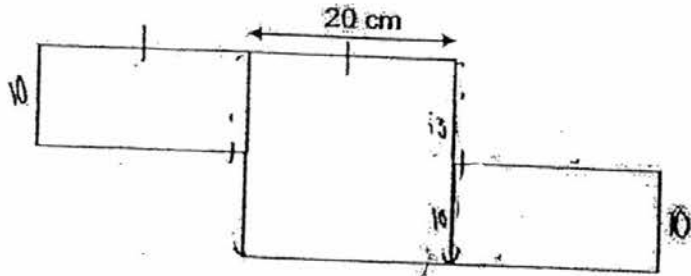

Ans: \_\_\_\_\_

28. Complete the figure using AB as the line of symmetry.

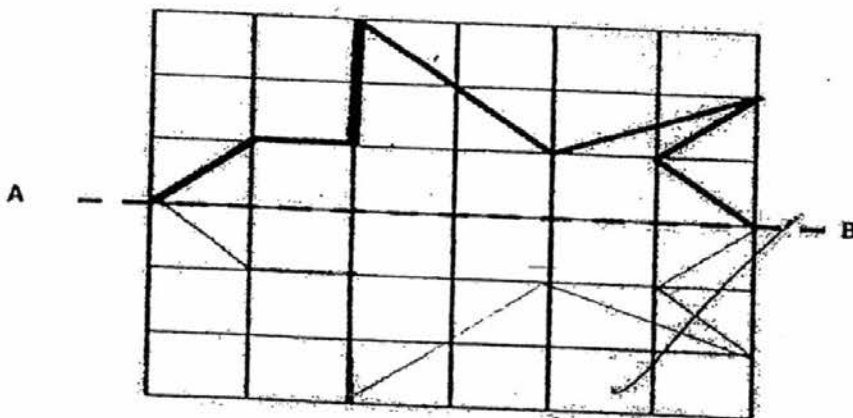

29. The figure below is not drawn to scale.  
 $\angle ABC$  is a right angle.  $\angle r$  is twice of  $\angle s$ .  $\angle DBE = 54^\circ$ .  
 Find  $\angle s$ .

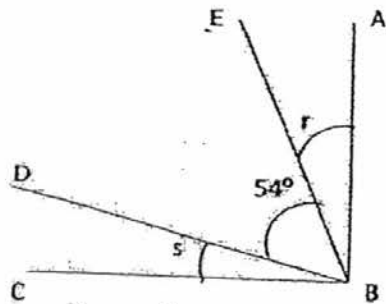

Ans: \_\_\_\_\_

30. Mrs Lee earns \$950 a month. How much would she earn in a year?

Ans: \_\_\_\_\_

31. Draw  $\angle ABC = 135^\circ$  on the given line AB. Mark and label your angle clearly.

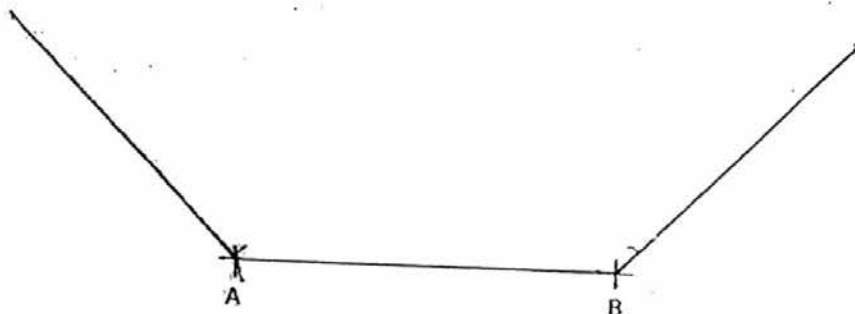

32. Use the 8-point compass shown below to answer the following questions.

(a) Sally was facing East. She made a  $\frac{3}{4}$ -turn clockwise. Which direction is she facing now?

(b) Lily was facing North after turning  $135^\circ$  anti-clockwise. Which direction was she facing at first?

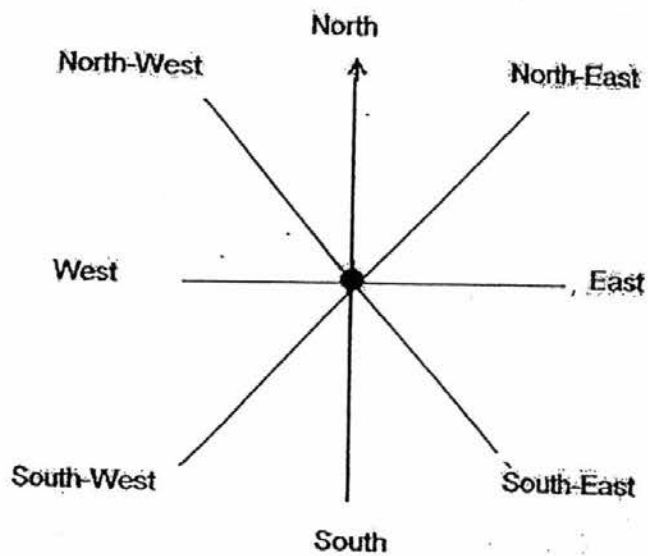

Ans: (a) \_\_\_\_\_

Ans: (b) \_\_\_\_\_

33. Draw a rectangle DEFG such that  $DE = 9$  cm and  $EF = 6$  cm.

34. Draw a line to indicate the line of symmetry on the figure below.

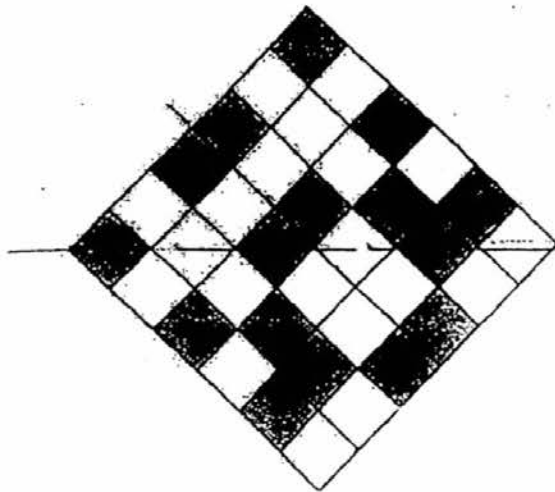

35. I am an even number between 20 and 30. When I am divided by 3, I have a remainder of 1. When I am divided by 5, I have a remainder 3. What am I?

Ans: \_\_\_\_\_

36. The difference between two numbers is 1368. The bigger number is four times the smaller number. What is the smaller number?

Ans: \_\_\_\_\_

**End of Booklet B**



METHODIST GIRLS' SCHOOL (PRIMARY)  
Founded in 1887



MID-YEAR EXAMINATION 2016  
PRIMARY 4  
MATHEMATICS

(BOOKLET C)

Total Time

Sections A to C: 1 hour 45 minutes

INSTRUCTIONS TO CANDIDATES

Do not turn over this page until you are told to do so.  
Follow all instructions carefully.  
Answer all questions.

Name: \_\_\_\_\_ ( )

Class: Primary 4. \_\_\_\_\_

Date: 10 May 2016

<b>Booklet A</b>	/ 36
<b>Booklet B</b>	/ 36
<b>Booklet C</b>	/ 28
<b>TOTAL</b>	/ 100

Parent's Signature: \_\_\_\_\_

This booklet consists of 9 printed pages including this page.

**Section C: (28marks)**

Show your working clearly in the space provided for each question and write your answers in the space provided.

The number of marks available is shown in brackets [ ] at the end of each question or part-question.

37. The price of a television set is \$325 cheaper than a washing machine.  
Mr Lim bought 3 television sets and 2 washing machines.  
He paid \$4 400 for the items in total.  
How much did the television <sup>a</sup>set <sup>set</sup> cost?

Ans: \_\_\_\_\_ [3]

38. Mr Lim bought 6 boxes of paper clips from a shop.  
Each box had an equal numbers of paper clips.  
He gave 8 paper clips to each of his 38 pupils. He then had 26 paper clips left.  
How many paper clips were there in each box?

Ans: \_\_\_\_\_ [3]

39. There were 4 times as many women as men who visited the Jurong Bird Park last Sunday. The number of women were twice that of the number of children. There were 2 340 children in all. How many people were there altogether? Round off your answer to the nearest hundreds.

Ans: \_\_\_\_\_ [3]

40. A figure is made up of 2 squares, ABCD and AXYZ.  
 AD is twice the length of AZ.  $\angle DCZ = \angle ZCX = \angle BCX$   
 The perimeter of ABCD is 360 cm.

(a) What is the length of XY?

(b) Find  $\angle s$ .

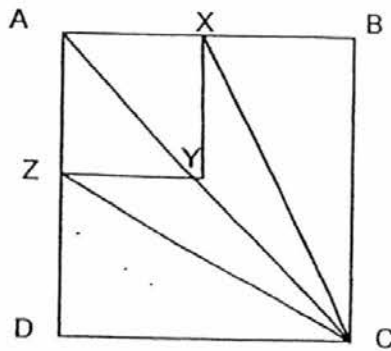

Ans : (a) \_\_\_\_\_ cm [2]

(b) \_\_\_\_\_ [2]

41. Aunt Mary had an equal number of pens and rulers.  
After donating 600 pens and 1050 rulers, she had three times as many pens as rulers.

(a) How many more rulers than pens did she donate?

(b) How many pens did she have at first?

Ans : (a) \_\_\_\_\_ [1]

(b) \_\_\_\_\_ [3]

42. The following graph below shows the number of participants for the River Charity Walk from 2012-2016.

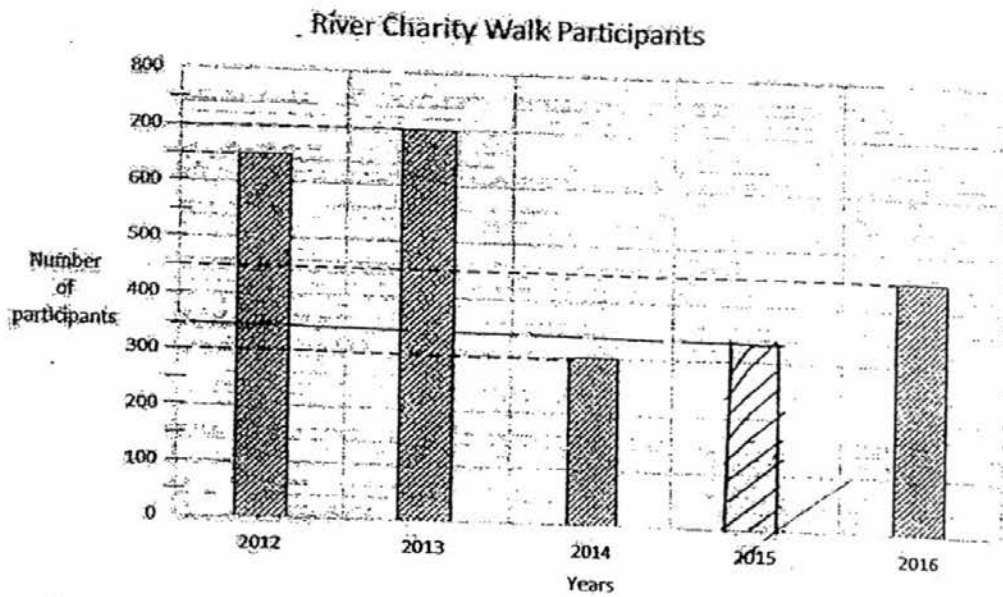

The number of participants for the River Charity Walk in 2015 is half that of the number of participants in 2013.

- (a) How many participants were there in 2015?  
Use your answer to complete the bar graph in the space provided above.
- (b) What is the total number of participants from 2012 to 2016?

Ans : (a) \_\_\_\_\_ [2]

(b) \_\_\_\_\_ [2]

43. The figure below is made up of a square  $WXYZ$  of side 32 cm,  $QW=WP=PX$ .

- (a) What is the perimeter of the square?
- (b) What is the area of the shaded part?

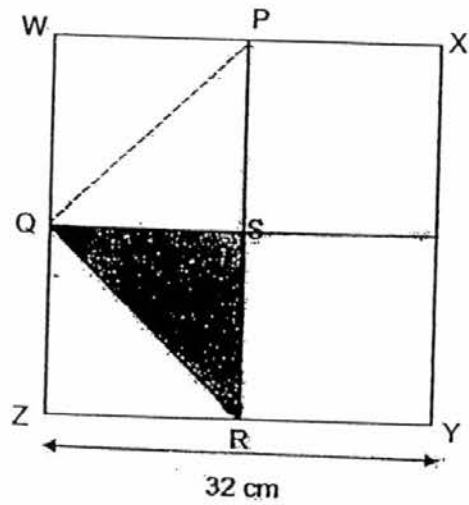

Ans: (a) \_\_\_\_\_ [4]

(b) \_\_\_\_\_ [3]



44. In 3 years' time, Sally will be 6 times as old as John.

Their total age now is 50 years.

How old is Sally now?

Ans: \_\_\_\_\_ [4]

End of Booklet C



YEAR : 2016  
 LEVEL : PRIMARY 4  
 SCHOOL : METHODIST GIRLS'  
 SUBJECT : MATHEMATICS  
 TERM : SA1

Booklet A

Q1	2	Q4	3	Q7	3	Q10	1	Q13	4	Q16	4
Q2	3	Q5	2	Q8	3	Q11	3	Q14	2	Q17	4
Q3	2	Q6	4	Q9	1	Q12	2	Q15	4	Q18	4

Booklet B

Q19 Fifty nine thousand two hundred and forty eight

Q20 10 463

Q21 36

Q22 343

Q23 36, 18, 3, 12, 6

Q24 9 cartons

Q25 \$85

Q26  $12 \times 37 = 444 \approx \underline{440}$  stickers

Q27 160 cm

Q28

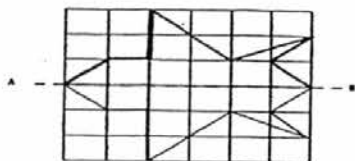

Q29  $12^\circ$

Q30  $950 \times 12 \Rightarrow \underline{\$11,400}$



Q31

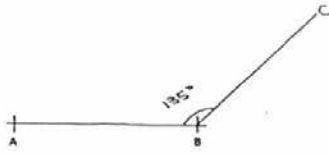

Q32a North

Q32b South-East

Q33

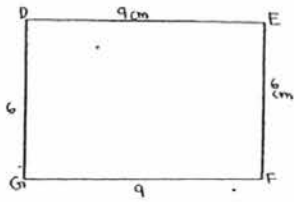

Q34

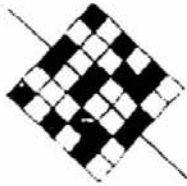

Q35 28

Q36 456

### Booklet C

Q37  $\$325 + \$325 \rightarrow \$650$   
 $\$4400 - \$650 \rightarrow \$3750$   
 $\$3750 \div 5 \Rightarrow \underline{\$750}$

Q38  $8 \times 38 \rightarrow 304$   
 $304 + 26 \rightarrow 330$   
 $330 \div 6 \Rightarrow \underline{55 \text{ paper clips}}$

Q39  $1170 \times 7 \rightarrow 8190$   
 $8190 \approx \underline{8200 \text{ people}}$



- Q40a  $AB = 360 \div 4 \rightarrow 90$   
 $XY = 90 \div 2 \Rightarrow \underline{45 \text{ cm}}$
- Q40b  $30^\circ$
- Q41a  $1050 - 600 \Rightarrow \underline{450}$
- Q41b  $450 = 2 \text{ units}$   
 $450 \div 2 = 225$   
 $225 = 1 \text{ unit}$   
 $225 \times 3 = 675$   
 $675 + 600 \Rightarrow \underline{1275 \text{ pens}}$
- Q42a  $700 \div 2 \Rightarrow \underline{350 \text{ participants}}$
- Q42b  $650 + 700 = 1350$   
 $1350 + 300 + 350 = 2000$   
 $2000 + 450 \Rightarrow \underline{2450 \text{ participants}}$
- Q43a  $32 + 32 + 32 + 32 \Rightarrow \underline{128 \text{ cm}}$
- Q43b Area of Big Square:  $32 \times 32 \rightarrow 1024$   
 $1024 \div 8 \Rightarrow \underline{128 \text{ cm}^2}$
- Q44  $3 \times 2 = 6$   
 $50 + 6 = 56$   
In 3 years' time, Sally + John = 56  
 $6 + 1 = 7$   
 $56 \div 7 = 8$   
 $8 = 1 \text{ unit}$   
 $8 \times 6 = 48$   
 $48 - 3 \Rightarrow \underline{45 \text{ years old}}$