



**Maha Bodhi School**  
**2015 Semestral Assessment 1**  
**Mathematics**

Name : \_\_\_\_\_ (     )

Date : 12 May 2015

Class : Pr 4 \_\_\_\_\_

Duration : 1 h 45 min

---

**BOOKLET A**

**Section A ( 40 marks )**

Questions 1 to 20 carry 2 marks each.

For each question, four options are given. One of them is the correct answer.

Make your choice (1, 2, 3 or 4). Shade the oval (1, 2, 3 or 4) on the Optical Mark Sheet.

What is the value of the digit 9 in 89 512?

- (1) 90
- (2) 900
- (3) 9000
- (4) 90 000

Which one of the following numbers is a common multiple of 6 and 8?

- (1) 12
- (2) 2
- (3) 3
- (4) 24

3. Express  $4\frac{3}{5}$  as an improper fraction.

(1)  $\frac{17}{5}$

(2)  $\frac{23}{5}$

(3)  $\frac{27}{5}$

(4)  $\frac{43}{5}$

4. Find the value of  $\frac{4}{9} + \frac{1}{3}$ .

(1)  $\frac{1}{2}$

(2)  $\frac{1}{3}$

(3)  $\frac{7}{9}$

(4)  $\frac{5}{12}$

5. Which one of the following pairs of lines is parallel?

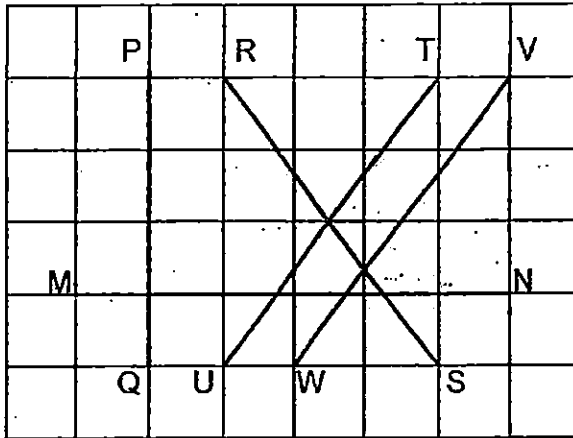

- (1) MN and PQ
- (2) TU and VW
- (3) TU and RS
- (4) PQ and RS

6. How many right angles are there inside the figure below?

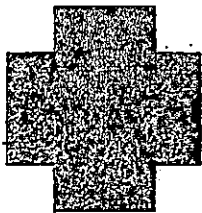

- (1) 12
- (2) 10
- (3) 8
- (4) 4

7. What is  $\angle ABC$ ?

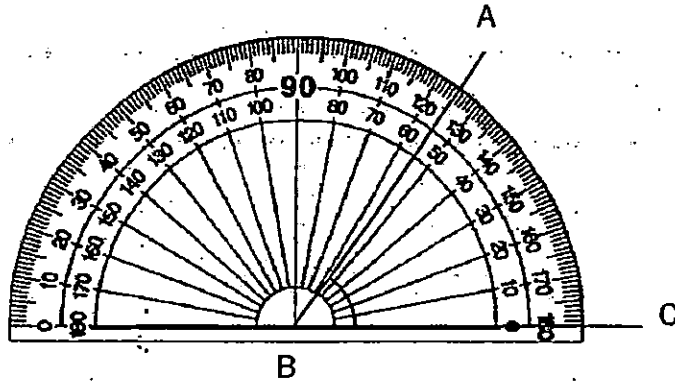

- (1)  $55^\circ$
- (2)  $65^\circ$
- (3)  $125^\circ$
- (4)  $135^\circ$

8. Boon Hua bought a Bingo set for \$28.95 and had \$11.05 left. How much did Boon Hua have at first?

- (1) \$17.90
- (2) \$17.45
- (3) \$39.90
- (4) \$40.00

9. There were 35 940 adults at a stadium. There were 5000 fewer children than adults. How many children were at the stadium?

- (1) 30 940
- (2) 35 440
- (3) 36 440
- (4) 40 940

10. Which of the following numbers are arranged in decreasing order?

(1) 56 789, 67 985, 68 795

(2) 68 795, 67 958, 65 789

(3) 56 798, 67 589, 65 879

(4) 68 579, 65 789, 67 985

11. Which fraction below is greater than  $\frac{3}{5}$ ?

(1)  $\frac{1}{9}$

(2)  $\frac{2}{3}$

(3)  $\frac{3}{8}$

(4)  $\frac{4}{7}$

12. Thomas made a half-turn in an anticlockwise direction. Then he made a quarter turn in the clockwise direction. He is now facing the playground.

Where was Thomas facing at first?

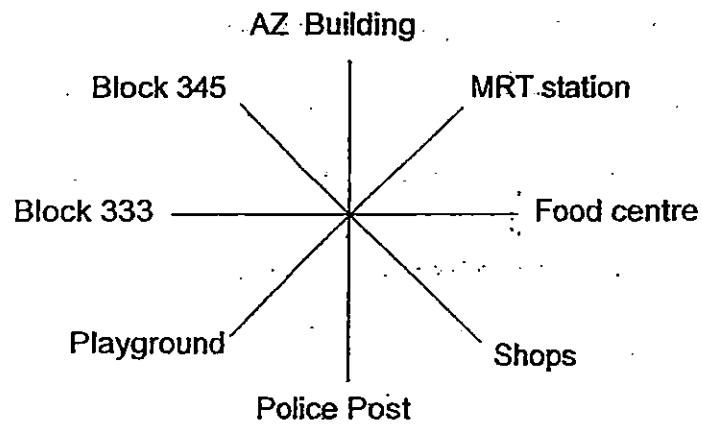

- (1) Shops
- (2) Block 345
- (3) MRT station
- (4) Food Centre.

13. The figure below shows a rectangle. What is the sum of  $\angle a$  and  $\angle b$ ?

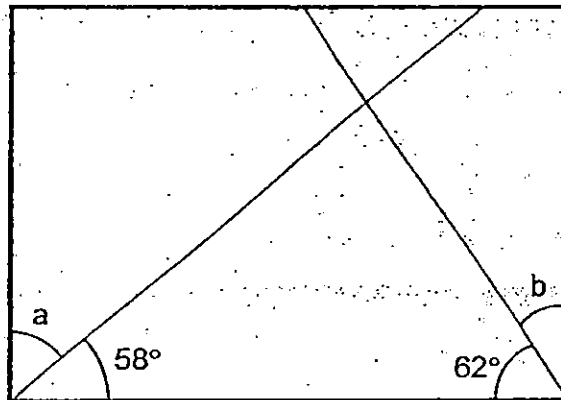

- (1)  $28^\circ$
- (2)  $32^\circ$
- (3)  $60^\circ$
- (4)  $120^\circ$

14. The mass of a durian is 1120 g. It is 88 g lighter than a watermelon. What is the mass of the watermelon? Give your answer in kg and g.

- (1) 1 kg 900 g
- (2) 1 kg 208 g
- (3) 1 kg 168 g
- (4) 1 kg 32 g

15. A seamstress takes 20 minutes to sew a curtain. She sews 10 curtains a day. On Monday, she started sewing at 1.20 p.m. without taking a break. What time did she finish?

- (1) 2.40 p.m.
- (2) 3.20 p.m.
- (3) 4.20 p.m.
- (4) 4.40 p.m.

16. There were 1168 more red marbles than green marbles in a box. Another 376 red marbles and 572 green marbles were put into the box. How many more red marbles than green marbles were there in the box?

- (1) 196
- (2) 220
- (3) 596
- (4) 972

17. Kenny had 60 marbles. He gave  $\frac{3}{5}$  of them to his friend and lost 5 marbles in a game. How many marbles had he left?

- (1) 19
- (2) 22
- (3) 24
- (4) 31

18. Figure A is made up of 2 identical squares. Figure B has the same perimeter as Figure A. Find the length of one square in Figure A.

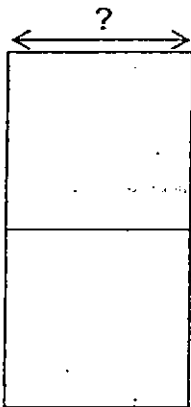

Figure A

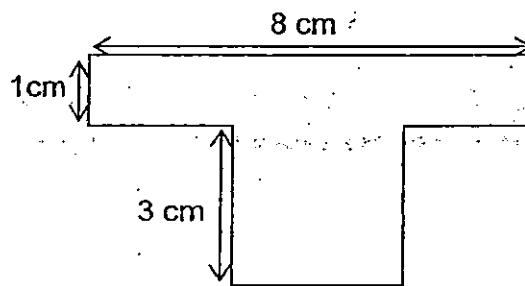

Figure B

- (1) 6 cm
- (2) 2 cm
- (3) 3 cm
- (4) 4 cm



19. Joe took 20 minutes to draw a picture and another 1 hour 30 minutes to colour the picture. He completed it at 12 noon. At what time did he start to draw his picture?

- (1) 10.10 a.m.
- (2) 11.30 a.m.
- (3) 1.30 p.m.
- (4) 1.50 p.m.

20.

$$\text{●} \times \text{●} = 36$$

$$\text{●} + \text{●} = Q$$

What is the value of Q?

- (1) 6
- (2) 12
- (3) 18
- (4) 36



**Maha Bodhi School**  
**2015 Semestral Assessment 1**  
**Mathematics**

Name : \_\_\_\_\_ ( )

Class : Pr 4 \_\_\_\_\_

Duration : 1 h 45 min

Date : 12 May 2015

Section A	/ 40
Section B	/ 40
Section C	/ 20
Total	/ 100

Parent's Signature : \_\_\_\_\_

**BOOKLET B**

**Section B ( 40 marks )**

Questions 21 to 40 carry 2 marks each.

Write your answers in the spaces provided, giving the answers in the units stated.

Show your working clearly in the space provided below each question.

Marks will be awarded for correct method shown.

21. Write 34 715 in words.

Ans: \_\_\_\_\_

22. 12 750 , 32 750 , 52 750 , 72 750 , ?

What is the missing number in the box?

Ans: \_\_\_\_\_

23. Write  $\frac{43}{6}$  as a mixed number in its simplest form.

Ans: \_\_\_\_\_

24. Which two of the fractions below are equivalent to  $\frac{8}{12}$ ?

$$\frac{16}{24}, \quad \frac{4}{8}, \quad \frac{3}{6}, \quad \frac{2}{3}$$

Ans: \_\_\_\_\_ and \_\_\_\_\_

25. Draw a line perpendicular to line AB and passing through point Y.

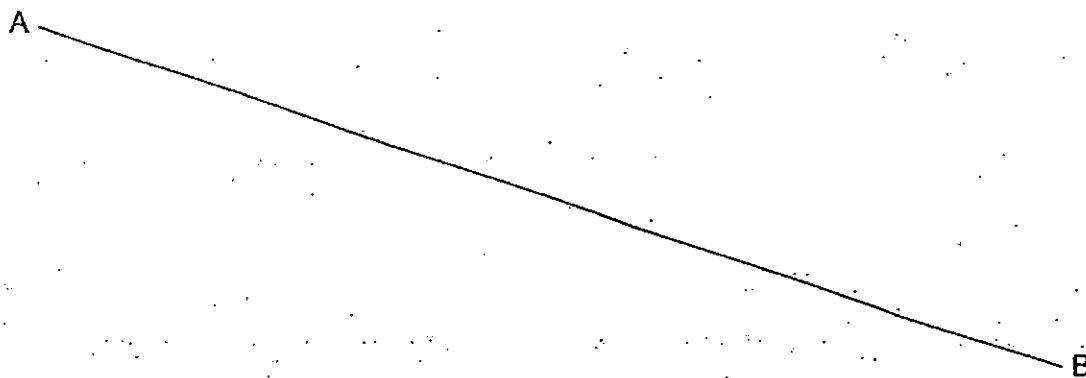

/ 6

26. Measure and write down the size of  $\angle x$ .

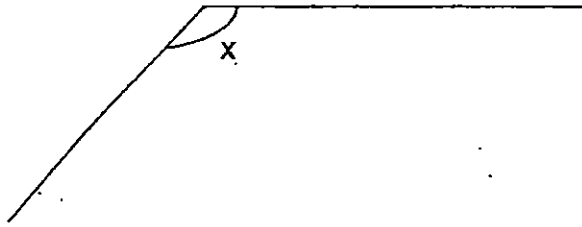

Ans: \_\_\_\_\_<sup>o</sup>

27. The length of a square is 5 cm. Find its area.

Ans: \_\_\_\_\_  $\text{cm}^2$

28. Find the first two common multiples of 4 and 8.

Ans: \_\_\_\_\_, \_\_\_\_\_

29. Mr Tan can pack 1620 books in 3 days. He packs an equal number of books each day.  
How many books can he pack in 5 days?

Ans: \_\_\_\_\_ books

30. Mrs See had  $\frac{7}{8}$  kg of flour. She gave  $\frac{1}{4}$  kg of flour to Miss Lim and  $\frac{1}{2}$  kg of flour to Mrs Khan. How much flour had she left?

Ans: \_\_\_\_\_ kg

31. There are 240 pens in a box.  $\frac{1}{6}$  of them are red pens and the rest are blue pens.  
How many blue pens are there in the box?

Ans: \_\_\_\_\_ blue pens.

/ 6

32. Muthu took 1 h 10 min to complete his Mathematics homework. He took 55 minutes to finish his English homework.

How much time did Muthu take to do his homework in all?

Ans: \_\_\_\_\_ h \_\_\_\_\_ min

33. The bar graph below shows the number of bowls of laksa sold at Stall C over 5 days.

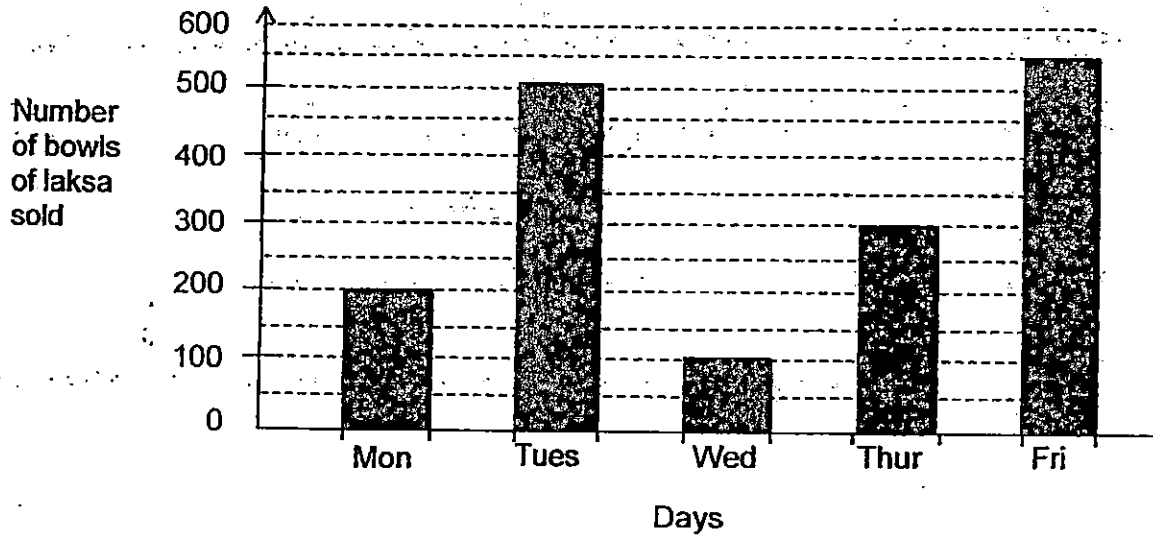

Find the total number of bowls of laksa sold on the day with the highest sales and on the day with the lowest sales.

Ans: \_\_\_\_\_ bowls

1 / 2

34. The line graph shows the mass (rounded off to the nearest 10 kg) of old newspapers Tom collected in five days.

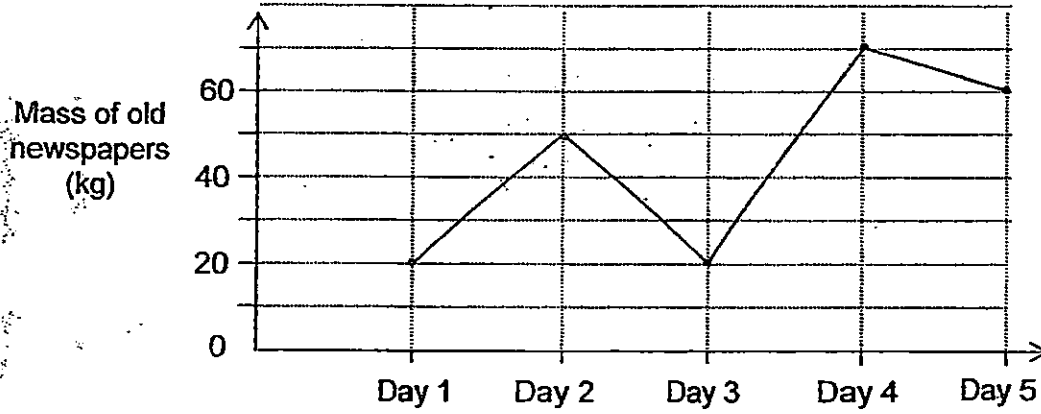

How much more old newspapers did Tom collect on Day 4 than Day 3?

Ans: \_\_\_\_\_ kg

1 / 2



35. Look at the figure below.

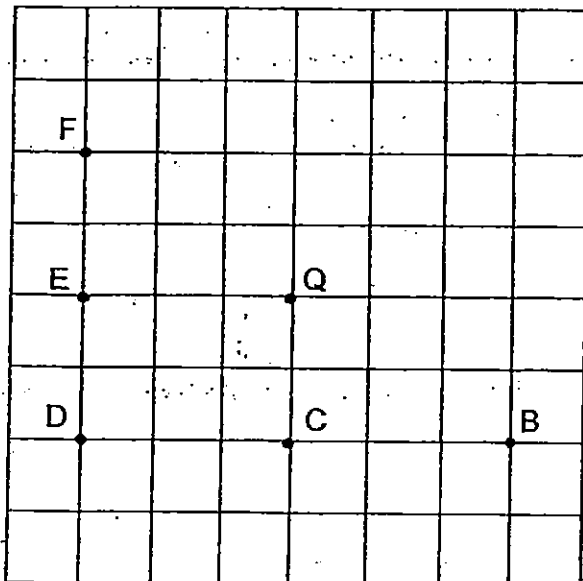

Refer to the square grid above.

- (a) Which point is north of point E?
- (b) Which point is south-west of point Q?

Ans: (a) \_\_\_\_\_  
(b) \_\_\_\_\_

36. There are 9 times as many adults as children in a cinema.  
There are 105 children and 438 men.  
How many women are there in the cinema?

Ans: \_\_\_\_\_ women

/ 4

37. The table below shows the number of families living in different types of HDB flats in a new town last year.

Type of HDB flat	1-room	2-room	3-room	4-room
Number of families	38	26	123	117

This year, 12 families from the 1-room flats and 15 families from a 2-room flats moved to 4-room flats. At the same time, 11 families from 3-room flats moved to 2-room flats.

How many families live in a HDB flat with less than 3 rooms this year?

Ans: \_\_\_\_\_ families

38. The figure GHIJKL is made up of a square and a rectangle. Find the length of GH.

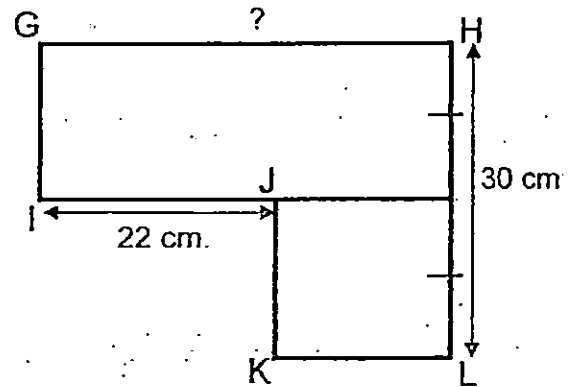

Ans: \_\_\_\_\_ cm

/ 4
-----

39. Lily wants to buy 20 identical pens as shown below.



1 for \$4.50

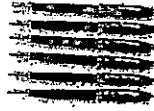

6 for \$23

What is the least amount of money she needs to buy 20 such pens?

Ans: \$ \_\_\_\_\_

40. Adrian wants to cut some 3-cm squares from a piece of rectangular paper shown below.

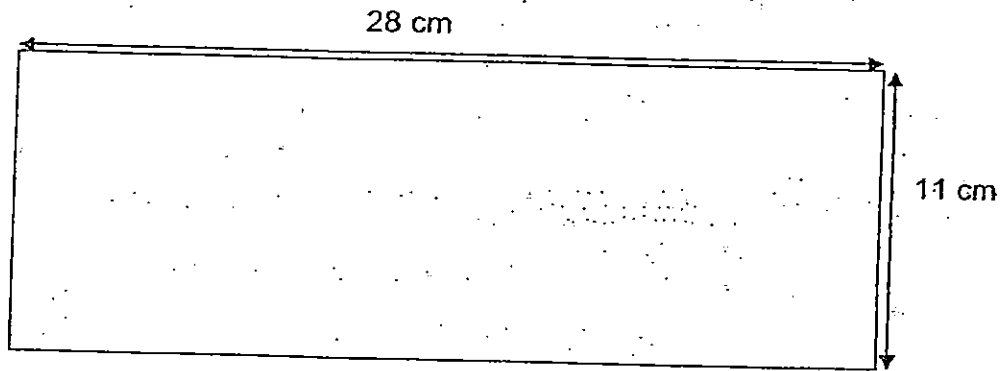
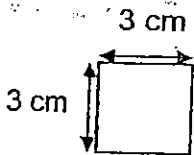

What is the greatest number of squares he can cut out?

Ans: \_\_\_\_\_ squares

/ 4
-----

**Section C ( 20 marks )**

Questions 41 to 45 carry 4 marks each.

Show your working clearly in the space below each question.

41. Dave had 3317 stamps. He gave away 26 stamps. His father then gave him 517 stamps. He arranged all his stamps in 7 albums equally. How many stamps did he arrange in each album?

42. Ronnie spent  $\frac{1}{5}$  of his money on a pair of shoes. He spent  $\frac{1}{2}$  of his money on a watch. After his spending, he had \$210 left. How much did he have at first?

43. 6 l of water is poured into two empty pails.

After pouring, 1 pail contains 80 ml more water than the other pail.

How much water is there in the other pail?

44. Gopal went to a shop with 3 fifty-dollar notes. He bought a watch and a calculator.

A watch cost 3 times as much as a calculator. He received \$32.40 change.

How much did the calculator cost?

45. Shanti was twice as old as Ismail 6 years ago.  
Their total age is 36 years now. How old is Ismail now?



*Remember to check your work!  
Every mark counts.*

*–End of Paper–*

---

This is the property of Maha Bodhi School.  
No part of this should be duplicated without the permission of Maha Bodhi School.



EXAM PAPER 2015

LEVEL : PRIMARY 4

SCHOOL : MAHA BODHI SCHOOL

SUBJECT : MATHEMATICS

TERM : SA1

Q1	Q2	Q3	Q4	Q5	Q6	Q7	Q8	Q9	Q10
3	4	2	3	2	3	1	4	1	2
Q11	Q12	Q13	Q14	Q15	Q16	Q17	Q18	Q19	Q20
2	2	3	2	4	4	1	4	1	2

Q21. Thirty four thousand, seven hundred and fifteen

Q22. 92 750

Q23.  $7\frac{1}{6}$

Q24.  $\frac{16}{24}$  and  $\frac{2}{3}$

Q25. SEE PICTURE

Q26.  $132^\circ$

Q27.  $25\text{cm}^2$

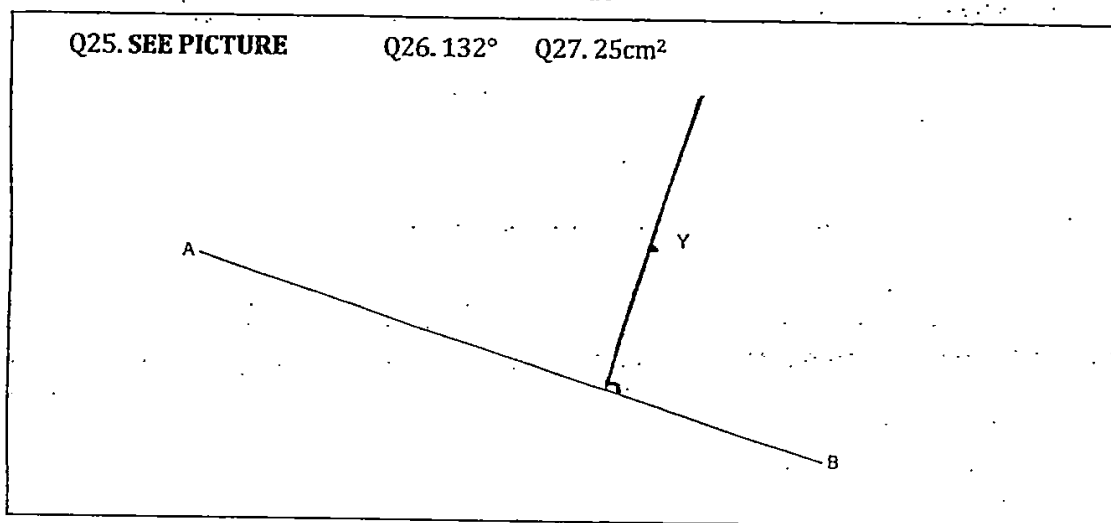

Q28. 8, 16

Q29. 2700 books  $\rightarrow 540 \times 5 = 2700$

Q30.  $\frac{1}{8}\text{kg} \times \frac{7}{8} - \frac{2}{8} = \frac{1}{8}$

Q31. 200 blue pens  $\rightarrow \frac{1}{5} \times 240 = 40$

Q32. 2h 5min  $\rightarrow 1\text{h } 10\text{min} + 55\text{min} = 2\text{h } 05\text{min}$

Q33. 650 bowls  $\rightarrow 550 + 100 = 650$

Q34. 50kg  $\rightarrow 70 - 20 = 50$

Q35a. F

Q35b. D

Q36. 507 women  $\rightarrow 105 \times 9 = 945, 945 - 438 = 507$

Q37. 48 families  $\rightarrow 12+4=16, 26-16=10, 10 \times 38=48$

Q38. 37cm  $\rightarrow 22-15=37$

Q39. \$78  $\rightarrow 23 \times 3 = 69, 69 + 4.50 + 4.50 = 78.00$

Q40. 27 squares  $\rightarrow 28 \div 3 = 9\text{R}1, 11 \div 3 = 3\text{R}2, 9 \times 3 = 27$

Q41. 544 stamps in each album

$3317 - 26 = 3291, 3291 + 517 = 3808, 3808 \div 7 = 544$

Q42. \$700  $\rightarrow$   $210 \div 3$ ,  $70 \times 10 = 700$

Q43. 2l 960ml of water

$6000\text{ml} - 80\text{ml} = 5920\text{ml}$ ,  $5920\text{ml} \div 2 = 2960\text{ml}$ ,  $2960\text{ml} = 2\text{l } 960\text{ml}$

Q44. \$29.40

$50 \times 3 = 150$ ,  $150 - 32.40 = 117.60$ ,  $117.60 \div 4 = 29.40$

Q45. 14 years old now

$36 - 6 - 6 = 24$ ,  $24 \div 3 = 8$ ,  $8 + 6 = 14$

**THE END**