



# RED SWASTIKA SCHOOL

## SCIENCE 2020 SEMESTRAL EXAMINATION 2 PRIMARY 3

Name : \_\_\_\_\_ (     )

Class : Primary 3/ \_\_\_\_\_

Date : 2 November 2020

### BOOKLET A

Total time for Booklets A & B: 1h 30 min

Booklet A: 15 questions (30 marks)





Note:

1. Do not open the booklet until you are told to do so.
2. Read carefully the instructions given at the beginning of each part of the booklet.
3. Do not waste time. If the question is too difficult for you, go on to the next question.
4. Check your answers thoroughly and make sure you attempt every question.
5. In this booklet, you should have the following:
  - a. Page 1 to Page 9
  - b. Questions 1 to 15



For Questions 1 to 15, choose the most suitable answer and shade its number in the OAS provided.

1. Study the table below.

Living things	Non-living things
 <p data-bbox="555 813 603 840">frog</p>	 <p data-bbox="1018 813 1066 840">keys</p>
 <p data-bbox="531 1041 630 1068">housefly</p>	 <p data-bbox="994 1041 1093 1068">hibiscus</p>

Which one of the above was classified wrongly?

- (1) frog  
 (2) keys  
 (3) housefly  
 (4) hibiscus
2. Which of the following has hair as its outer body covering?
- (1) insect  
 (2) reptile  
 (3) mammal  
 (4) amphibian

3. Study the diagram of plant X shown below.

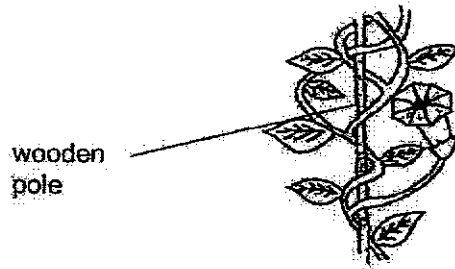

Plant X needs a wooden pole for support because it \_\_\_\_\_

- A: has a weak stem  
 B: needs to absorb more water  
 C: needs to reach up for more sunlight

- (1) A only  
 (2) A and C only  
 (3) B and C only  
 (4) A and B only

4. The table below shows the characteristics of four animals.

Characteristics	has six legs	has feathers	feeds its young with milk
bird	x	✓	x
fish	✓	x	x
insect	✓	x	✓
mammal	x	✓	✓

Which one of the following animals in the table is correctly described?

- (1) bird  
 (2) fish  
 (3) insect  
 (4) mammal

5. Which of the following organs is not part of the human respiratory system?
- (1) nose
  - (2) lungs
  - (3) heart
  - (4) windpipe
6. The diagram below shows one of the human body systems.

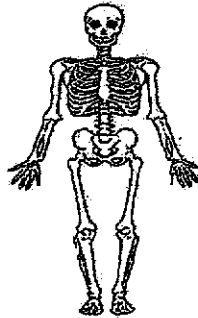

Some students shared statements about this human body system.

Abu:	It helps to give us shape.
Ben:	It helps to support our body.
Caela:	It helps to protect the important organs in our body.
David:	It helps to transport food and water to all parts of our body.

Which student made an incorrect statement?

- (1) Abu
- (2) Ben
- (3) Caela
- (4) David

7. The diagram below shows a plant.

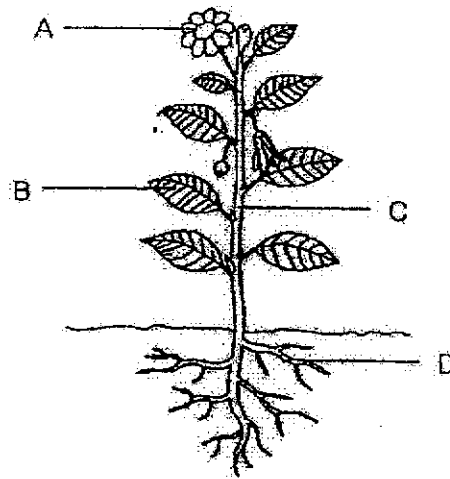

Which part of the plant, A, B, C or D, helps to hold the plant firmly to the ground?

- (1) A
- (2) B
- (3) C
- (4) D

8. The diagram below shows one of the organs in the human digestive system.



Which of the following information about the organ is correct?

	Organ	Digestion of food takes place here	Water is absorbed
(1)	Small Intestine	Yes	No
(2)	Small Intestine	No	Yes
(3)	Large Intestine	No	Yes
(4)	Large Intestine	Yes	No

9. Study the flow chart below.

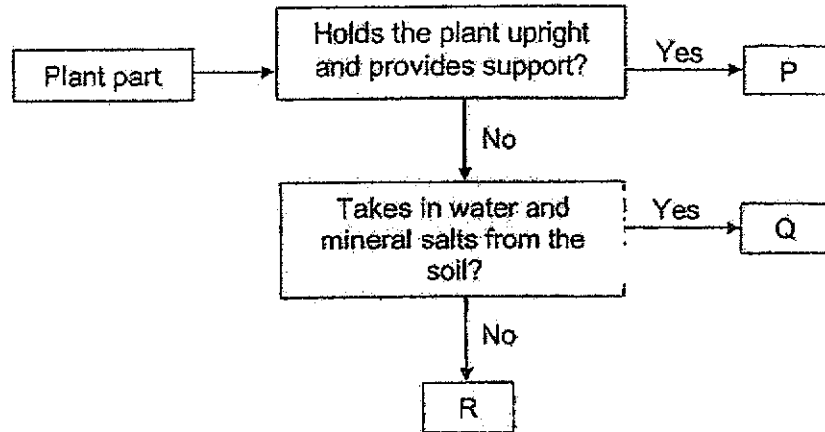

Which parts of a plant do P, Q and R represent?

	P	Q	R
(1)	stem	root	leaf
(2)	root	stem	leaf
(3)	stem	leaf	root
(4)	leaf	stem	root

10. The diagram shows a measuring tape. The measuring tape is used to measure the lengths of different objects.

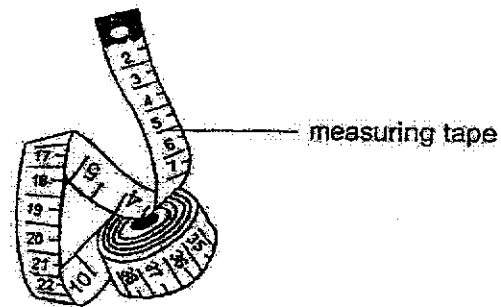

The table below shows the properties of four materials, A, B, C and D. A tick (✓) indicates that the material has the property and a cross (×) indicates that the material does not have that property.

Material	Strong	Flexible
A	✓	✓
B	×	✓
C	×	×
D	✓	×

Based on the properties shown above, which material is most suitable to make the measuring tape?

- (1) A
- (2) B
- (3) C
- (4) D



11. Susan hung metal clips to the poles of each magnet until the last clip could not be hung any more. The diagrams below show the results of her experiment.

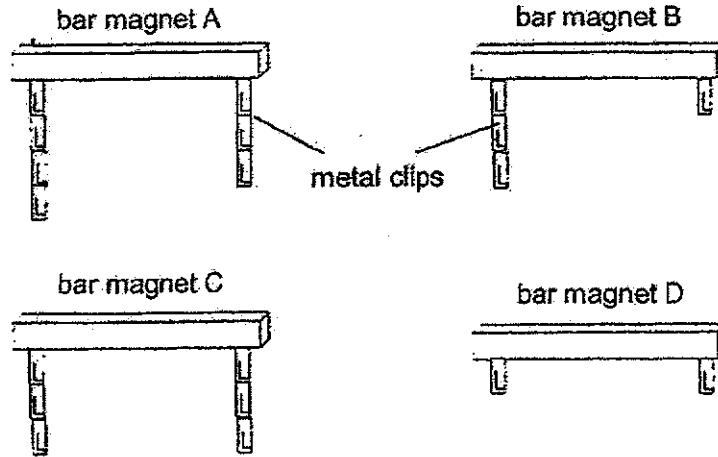

Which bar magnet has the weakest magnetic strength?

- (1) A
  - (2) B
  - (3) C
  - (4) D
12. Leah hung a magnet as shown in the diagram below. She gave the magnet a gentle push. The magnet turned and eventually stopped.

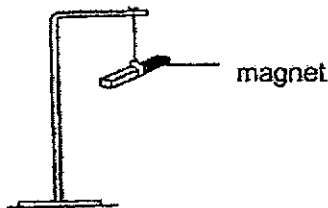

In which direction would the magnet come to a rest?

- (1) east-west
- (2) north-east
- (3) south-west
- (4) north-south

13. Jun Hong wanted to turn an iron nail into a temporary magnet. He used a bar magnet to stroke the iron nail in the same direction repeatedly as shown in the diagram.

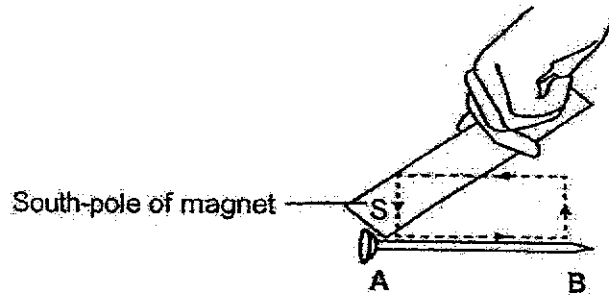

What will the poles of the temporary magnet be at points A and B?

	A	B
(1)	North	North
(2)	South	North
(3)	South	South
(4)	North	South

14. Linda placed two bar magnets next to each other. She drew four observations as seen in the diagrams below. She indicated the North-pole of the magnet with the letter 'N'. The arrows show the movement of the magnets towards or away from each other.

Which of the following diagrams shows the correct observation?

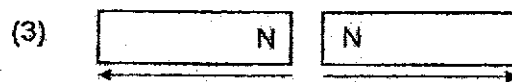
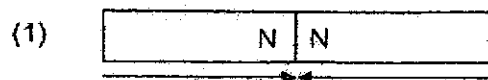

15. Shaun wanted to find out if the number of coils around an iron rod would affect the strength of the electromagnet. He set up the experiment as shown in the diagram below.

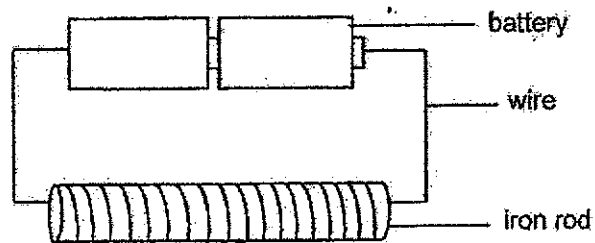

Shaun repeated the experiment with three other set-ups with different number of coils around the iron rod. He recorded the results in the table below.

Set-up	Number of pins attracted to the iron rod
P	13
Q	17
R	5
S	8

Which set-up likely had the most number of coils around the iron rod?

- (1) P
- (2) Q
- (3) R
- (4) S

End of Booklet A



# RED SWASTIKA SCHOOL

## SCIENCE 2020 SEMESTRAL EXAMINATION 2 PRIMARY 3

Name : \_\_\_\_\_ ( )

Class : Primary 3/ \_\_\_\_\_

Date : 2 November 2020

### BOOKLET B

6 Questions  
20 Marks

In this booklet, you should have the following:

- Page 10 to Page 16
- Questions 16 to 21

### MARKS

	OBTAINED	POSSIBLE
BOOKLET A		30
BOOKLET B		20
TOTAL		50

Parent's Signature : \_\_\_\_\_

Answer all questions in the space provided.

16. Organisms A, B, C and D have been classified as shown below.

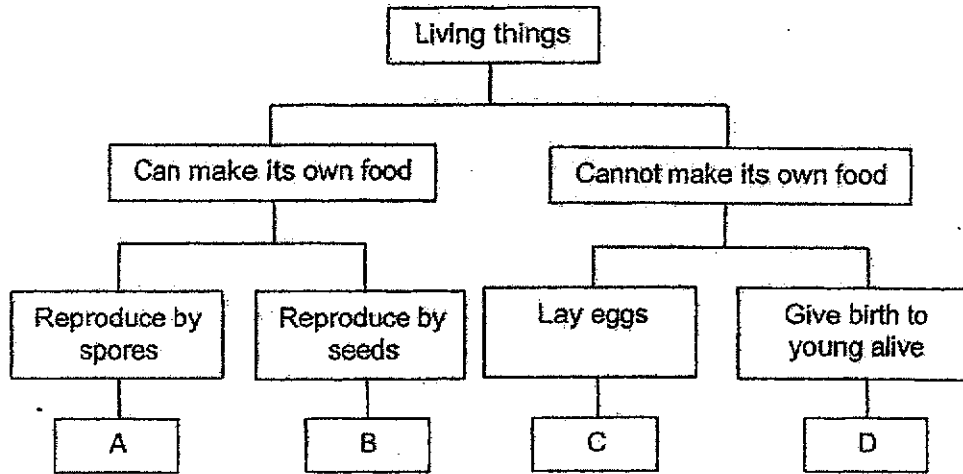

(a) Based on the classification chart, state one similarity between C and D. (1m)

---



---

(b) Which group of living things do A and B most likely belong to? (1m)

---

(c) Classify these organisms according to the classification chart. Fill in the blanks with the letters A, B, C or D. (2m)

Organism	Letter (A, B, C or D)
Bird's nest fern	
Elephant	

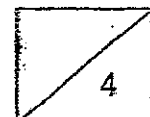

17. Study the organ system below.

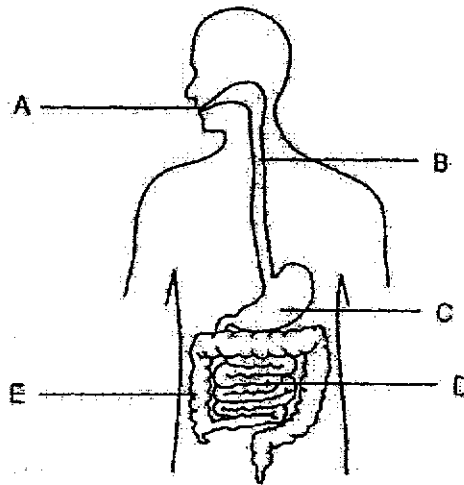

(a) Which organs, A, B, C, D or E, produce digestive juices?  
Put a tick (✓) if digestive juices are produced in the organ. You may tick more than one organ. (1m)

Organ	A	B	C	D	E
Digestive juices produced					

(b) Read the statements below. Write 'True' or 'False' in the correct boxes. (2m)

	Statements	True or False
(i)	Digestion starts in part B.	
(ii)	Digestion ends in part C.	
(iii)	Digested food passes through the walls of part D.	
(iv)	Undigested food in part E will pass out through the anus.	



18. The diagram below shows a plant.

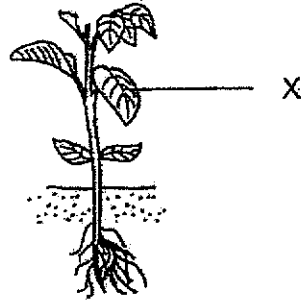

(a) State one function of part X of the plant? (1m)

---

Part of the plant was removed as shown in the diagram below. After a few days, the plant died.

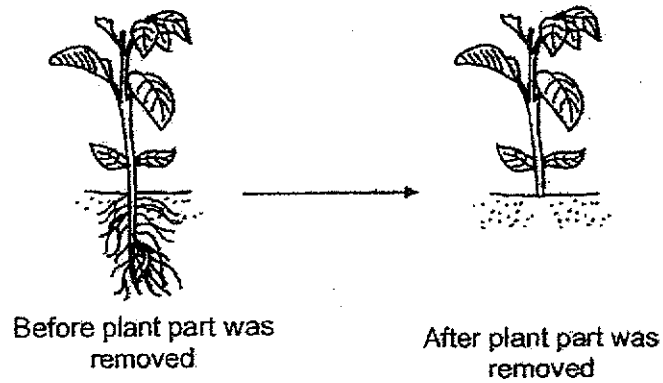

(b) Which part of the plant was removed? (1m)

---

(c) Explain how the removal of the plant part caused the plant to die. (1m)

---

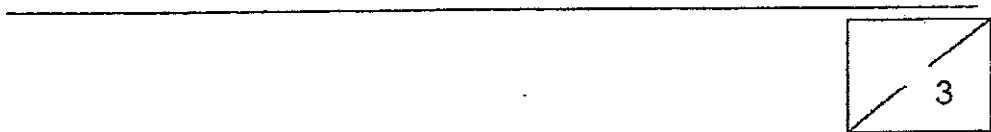

19. The table below shows the properties of four materials, A, B, C and D. A tick (✓) indicates that the material has the property and a cross (×) indicates that the material does not have the property.

Material	Flexible	Allows light to pass through
A	✓	✓
B	✓	×
C	×	✓
D	×	×

Chris wanted to make a fish tank as seen in the picture below.

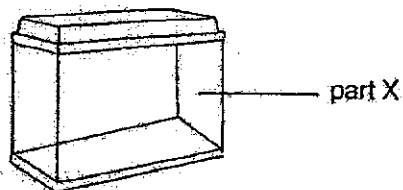

- (a) Based on the table, which material, A, B, C or D is most suitable to make part X of the tank? (1m)

---

- (b) Explain your answer for part (a). (1m)

---



---

- (c) Chris placed material D into a container of water. She observed the following as shown in the diagram below.

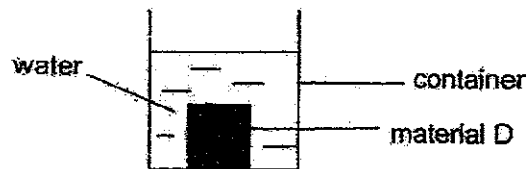

- Based on the diagram, which property of material can you tell about material D? (1m)

---

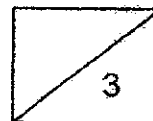



20. Leanne placed a magnet close to three objects made of different materials. An example of the set-up is shown below.

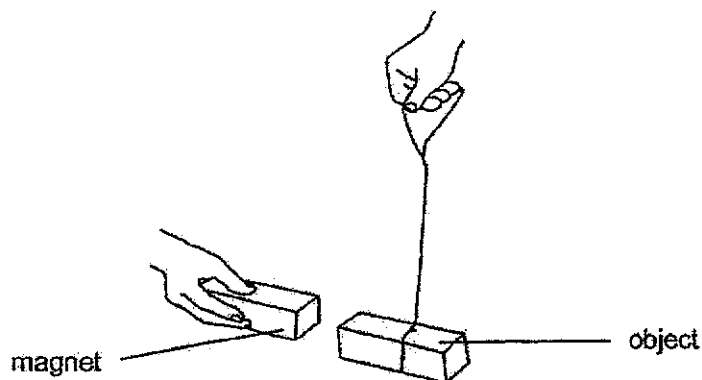

She moved the magnet slowly towards the objects. Then, she recorded her observations in the table as shown.

Objects	Observations	
	when facing north-pole of the magnet	when facing south-pole of the magnet
A	moved towards the magnet	moved towards the magnet
B	moved away from the magnet	moved towards the magnet
C	did not move	did not move

- (a) Which object, A, B or C, is likely to be a magnet? (1m)

---

- (b) Explain your answer in part (a). (1m)

---



---

- (c) Give an example of a material that object C can be made of. (1m)

---

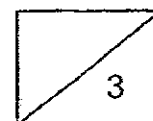

21. Min Yan conducted an experiment to find out which magnet (A, B, C or D) has the greatest magnetic strength. She set up the experiment as shown below.

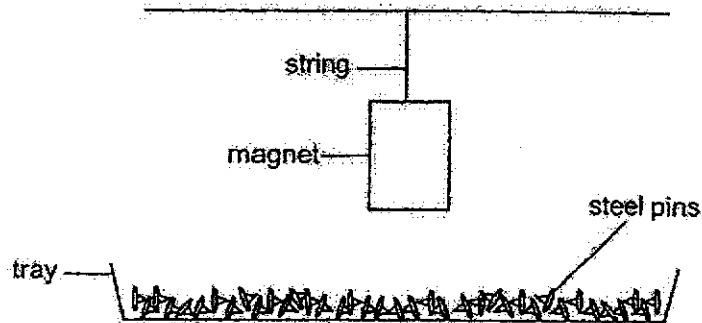

She hung magnets A, B, C and D from the same height and recorded the number of steel pins the magnet attracted in the table below.

Magnet	Number of steel pins attracted
A	5
B	13
C	16
D	9

- (a) Based on the table above, arrange the magnets according to their magnetic strength. Write the letters A, B, C and D in the correct boxes below. (1m)

(i)  , (ii)  , (iii)  , (iv)

weakest  → strongest

- (b) Without adding or removing anything from the set-up, what can Min Yan do to make the magnets attract more steel pins? (1m)

---



---

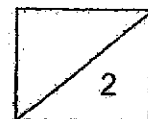

21. Min Yan wanted to find out if the number of strokes would affect the strength of the temporary magnet. She stroked an iron bar using a magnet repeatedly in the same direction as shown in the diagram below.

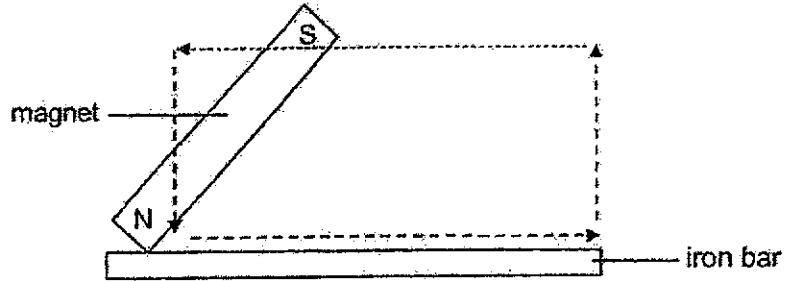

Min Yan then placed the temporary magnet over some steel pins to see how many steel pins the temporary magnet attracted. She recorded her results in the graph below.

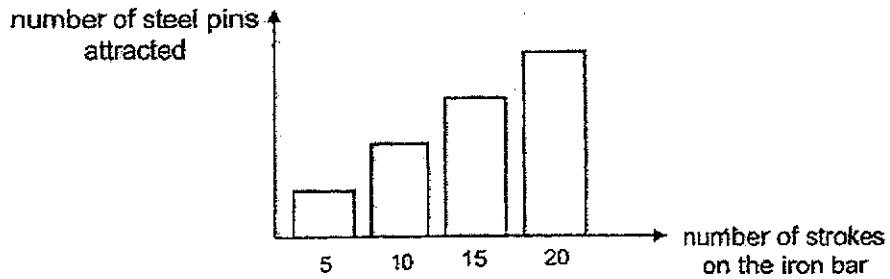

- (c) Based on the graph, what is the relationship between the number of strokes on the iron bar and the number of steel pins attracted? (1m)

---



---

- (d) Min Yan repeated the experiment with an aluminium bar instead. She found that she was not able to attract any steel pins. Why is this so? (1m)

---



---

End of Booklet B  
Please check your answers

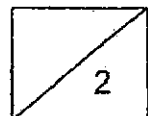



**ANSWER KEY****YEAR: 2020****LEVEL: PRIMARY 3****SCHOOL: RED SWASTIKA SCHOOL****SUBJECT: SCIENCE****TERM: SEMESTRAL EXAMINATION 2****BOOKLET A**

Q1	4	Q2	3	Q3	2	Q4	1	Q5	3
Q6	4	Q7	4	Q8	3	Q9	1	Q10	1
Q11	4	Q12	4	Q13	2	Q14	3	Q15	2

**BOOKLET B**

Q16	<p>a)Both C and D cannot make its own food.</p> <p>b)A and B most likely belongs to plant.</p> <p>c)Bird's nest fern: A</p> <p>Elephant: D</p>
Q17	<p>a)A,C,D</p> <p>(b)i)False</p> <p>ii)False</p> <p>iii)True</p> <p>iv)True</p>
Q18	<p>a)Part X helps the plant to make food.</p> <p>b)The roots of the plant was removed.</p> <p>c)When the plant do not have roots it cannot absorb water and so the plant will die without water.</p>
Q19	<p>a)C is the most suitable.</p> <p>b)Material C is not flexible and allows light to pass through.</p> <p>c)It sinks in water.</p>
Q20	<p>a)B is most likely a magnet.</p> <p>b)B is repelled by the magnet. Only magnets can be repel each other when their like poles are facing each other.</p> <p>c)Wood</p>

Q21	<p>a)(i)A (ii)D (iii)B (iv)C</p> <p>b)Make the string longer.</p> <p>c)The more you stroke the magnet to the iron bar, the more steel pins are attracted to the iron bar.</p> <p>d)That is because an aluminium bar is not magnetic</p>
-----	---