

**Red Swastika School**  
**Pr 3 Mathematics Revision Worksheet (1)**

Name : \_\_\_\_\_ (    )                      Date : \_\_\_\_\_

Class : Pr. 3 \_\_\_\_\_

**Section A : Multiple-Choice Questions**

Questions 1 to 20 carry 2 marks each. For each question, four options are given. One of them is the correct answer. Make your choice (1, 2, 3 or 4). Shade the correct oval (1, 2, 3 or 4) on the Optical Answer Sheet. (40 marks)

---

1      What is the value of the digit 4 in 9674?

- (1) 4000
- (2) 400
- (3) 40
- (4) 4

2      Which of the following is six thousand, two hundred and twelve in numerals?

- (1) 6012
- (2) 6200
- (3) 6212
- (4) 6220

3      Arrange the following numbers in order, beginning with the greatest.

8909, 989, 9098, 899



- (1) 899, 989, 8909, 9098
- (2) 9098, 8909, 989, 899
- (3) 8909, 9098, 989, 899
- (4) 9098, 8909, 899, 989

4      What is the value of  $2000 - 384$ ?

- (1) 1616
- (2) 1384
- (3) 1726
- (4) 2384

5 In the sum of 333 and 999, the digit in the \_\_\_\_\_ place is an even number.

- (1) ones
- (2) tens
- (3) hundreds
- (4) thousands

6  ×  = 64

What is the value of  ?

- (1) 6
- (2) 7
- (3) 8
- (4) 9

7 What is the remainder when 886 is divided by 6?

- (1) 1
- (2) 2
- (3) 3
- (4) 4

8 Which of the following does **not** have the same measurement as the rest?

- (1) 520 cm
- (2) 5 m 2 cm
- (3) 5 m 20 cm
- (4) 500 cm + 20 cm

- 9 How many minutes are there from 3.55 p.m. to 4.20 p.m.?

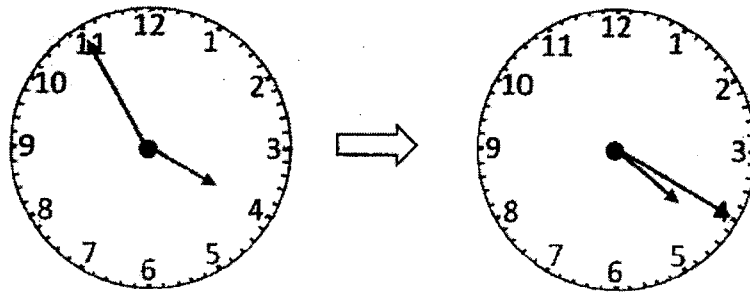

- (1) 20 minutes  
 (2) 25 minutes  
 (3) 35 minutes  
 (4) 55 minutes

- 10 Xiaomin only had the following five coins in her purse.



She donated two coins from her purse to charity during Children's Day. Which of the following amounts could she have donated?

- (1) 35 ¢  
 (2) 80 ¢  
 (3) \$1.15  
 (4) \$1.20

11 Look at the pictures below. How much more does the teddy bear cost than the toy train?

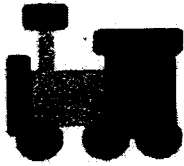

toy train  
\$17.90



teddy bear  
\$22.55



kite  
\$3.25



toy car  
\$18.65

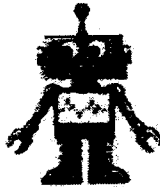

toy robot  
\$12.30

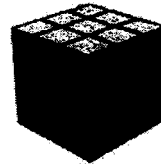

Rubik's cube  
\$5.50

- (1) \$3.90
- (2) \$4.10
- (3) \$4.65
- (4) \$5.45

12 Which of the following shapes has both perpendicular and parallel lines?

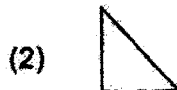

- 13 Find the area of the rectangle shown below.

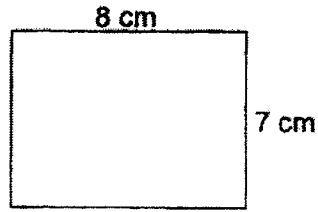

- (1)  $15 \text{ cm}^2$   
 (2)  $30 \text{ cm}^2$   
 (3)  $56 \text{ cm}^2$   
 (4)  $64 \text{ cm}^2$
- 14 What fraction of the rectangle ABCD is shaded?

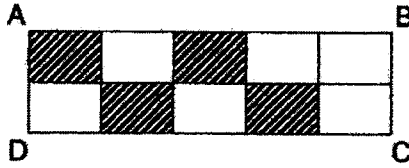

- (1)  $\frac{4}{6}$   
 (2)  $\frac{4}{8}$   
 (3)  $\frac{4}{10}$   
 (4)  $\frac{6}{10}$
- 15 In the number line below, A represents  $\frac{5}{8}$ , C represents  $\frac{7}{8}$ . What fraction is represented by B, given that B is exactly between A and C?

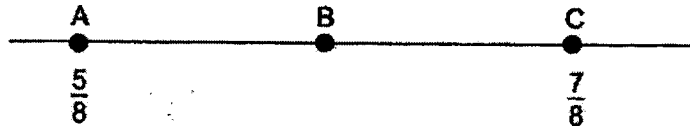

- (1)  $\frac{1}{4}$   
 (2)  $\frac{1}{2}$   
 (3)  $\frac{3}{4}$   
 (4)  $\frac{6}{16}$

- 16 A number when divided by 8 gives a remainder of 4. Which of the following can be added to the number so that it will leave no remainder when divided by 8?

- (1) 8  
 (2) 2  
 (3) 6  
 (4) 4

- 17 Adam, Bobby, Caden and Dennis collected some toy cars. Adam collected the least number of toy cars. Bobby collected more toy cars than Dennis but fewer than Caden. Who collected the most number of toy cars?

- (1) Adam  
 (2) Bobby  
 (3) Caden  
 (4) Dennis

- 18 Which of the following is likely to be the total mass of 10 eggs?

- (1) 4 g  
 (2) 4 kg  
 (3) 400 g  
 (4) 400 kg

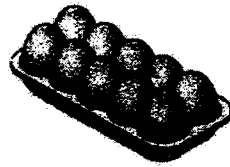





- 19 What are the missing digits in the boxes?

$$\begin{array}{r}
 \square 382 \\
 - 28\square 9 \\
 \hline
 1543
 \end{array}$$

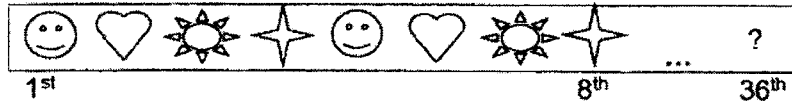
- (1)  $\square 382, 28\square 9$   
 (2)  $\square 382, 28\square 9$   
 (3)  $\square 4382, 28\square 39$   
 (4)  $\square 4382, 28\square 49$

- 20 Chris used stickers of four different shapes to make a pattern. The first 8 stickers are shown below. What was the shape of the 36<sup>th</sup> sticker?



- (1) 
- (2) 
- (3) 
- (4) 





**Red Swastika School**  
**Pr 3 Mathematics Revision Worksheet (2)**

Name : \_\_\_\_\_ (    )                      Date : \_\_\_\_\_

Class : Pr. 3 \_\_\_\_\_

**Section B : Short-Answer Questions**

Show your working clearly in the space below each question and write your answers in the spaces provided. For questions which require units, give your answers in the units stated.

---

- 21 Write the number that is represented by the diagram below.

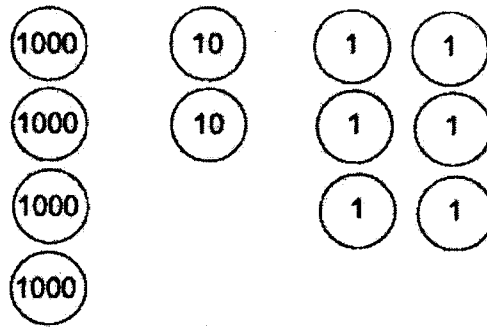

Ans: \_\_\_\_\_

---

- 22 Multiply 422 by 3.

Ans: \_\_\_\_\_

---

- 23 Use all the digits 6, 5, 1, 3 to form the smallest odd number.

Ans: \_\_\_\_\_

---

- 24 Six angles are marked in the figure. How many of them are larger than a right angle?

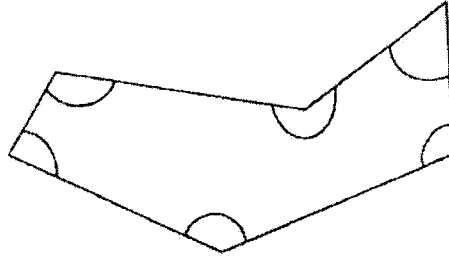

Ans: \_\_\_\_\_

- 25 The bar graph below shows the types of pets kept by the students in Class 3A.

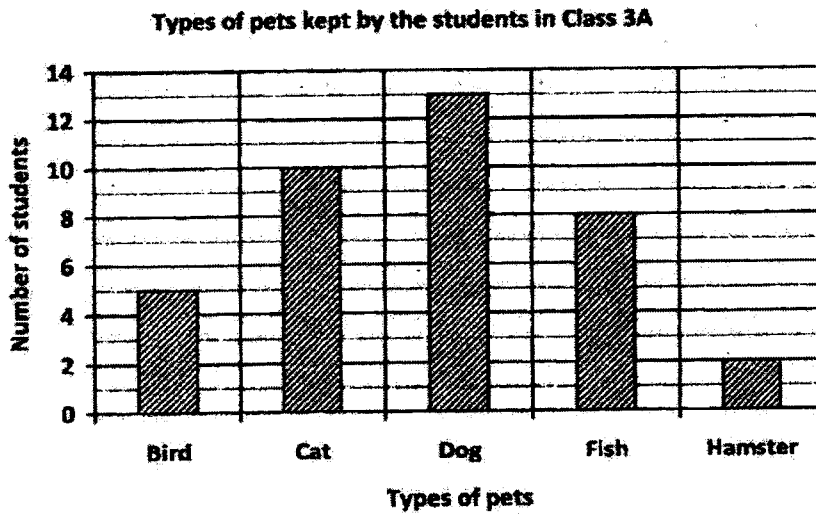

Each of the statements below is either true or false based on the information given. For each statement, put a tick (✓) to indicate your answer.

Statement	True	False
10 more students kept fish than hamsters as pets.		
There were twice as many students who kept cats as those who kept birds as pets.		

- 26** I am a 4-digit number.  
The digits in my thousands place and ones place are the same.  
The digit in my tens place is 8 less than the digit in my thousands place.  
The value of the digit in my hundreds place is 300.  
What number am I?

Ans: \_\_\_\_\_

---

- 27** Mrs Singh bought 45 cookies.  
She bought 9 times as many cookies as Mdm Aminah.  
How many cookies did Mdm Aminah buy?

Ans: \_\_\_\_\_

---

- 28** Mary had \$548. She had \$245 more than her sister.  
How much did her sister have?

Ans: \$ \_\_\_\_\_

---

- 29 Study the pattern below. What is the missing number?

220, 230, 200, \_\_\_\_, 180, 190

Ans: \_\_\_\_\_

- 30 Some plants were planted in a row at equal distances. The distance between the 1<sup>st</sup> and the 2<sup>nd</sup> plant was 655 m. What was the distance between the 1<sup>st</sup> and 6<sup>th</sup> plant? Give your answer in km and m.

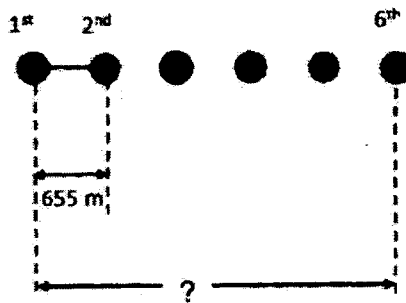

Ans: \_\_\_\_\_ km \_\_\_\_\_ m

- 31 Mrs Tan bought a packet of orange juice. She poured all the orange juice equally into 9 cups of 225 ml each. What is the volume of the orange juice in the packet? Give your answer in  $\ell$  and ml.

Ans: \_\_\_\_\_  $\ell$  \_\_\_\_\_ ml

The bar graph below shows the number of four types of files sold by a shopkeeper last month.  
Use the graph to answer Questions 32 and 33.

The number of four types of files sold

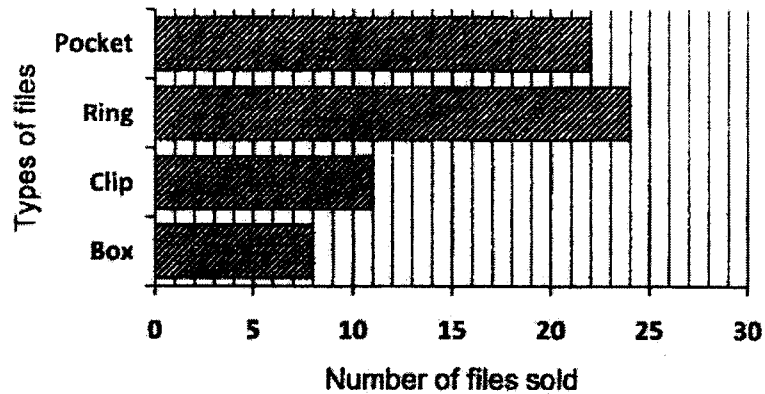

- 32 The shopkeeper sold 3 times as many ring files as \_\_\_\_\_ files.

Ans: \_\_\_\_\_

- 33 The clip file cost 4 times as much as a pocket file. The shopkeeper collected more money selling the \_\_\_\_\_ (clip / pocket) files last month.

Ans: \_\_\_\_\_

- 34 The figure below is made up of a square and a triangle of equal sides. Find the perimeter of the figure.

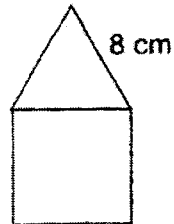

Ans: \_\_\_\_\_ cm

---

- 35 A pair of jeans cost \$66. A skirt is \$9.20 cheaper than the jeans. Find the cost of the skirt.

Ans: \$ \_\_\_\_\_

---

- 36 The table below shows the opening hours of a clinic.

Morning	8.00 a.m. to 11.30 a.m.
Afternoon	2.00 p.m. to 4.00 p.m.
Evening	6.30 p.m. to 9.00 p.m.

How many hours is the clinic open in a day?

Ans: \_\_\_\_\_

---

- 37 Draw two more straight lines to form a 4-sided figure with two right angles, one obtuse angle and one acute angle.

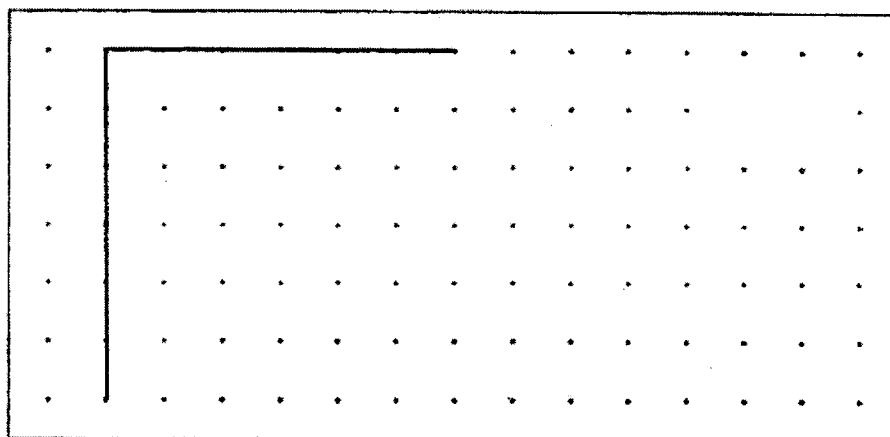

- 
- 38 What are the missing numbers in the fractions below?

$$\frac{2}{a} = \frac{6}{15} = \frac{b}{25}$$

Ans: a = \_\_\_\_\_

b = \_\_\_\_\_

- 
- 39 Which of the following fractions is smaller than  $\frac{1}{3}$ ?

$$\frac{2}{9}, \frac{1}{2}, \frac{5}{6}$$

Ans: \_\_\_\_\_

- 40 Andy, Beth and Candy shared a rectangular cake.  
Andy took  $\frac{5}{8}$  of the cake, while Beth took  $\frac{1}{4}$  of it.  
Shade in the figure below the amount of cake Candy took.

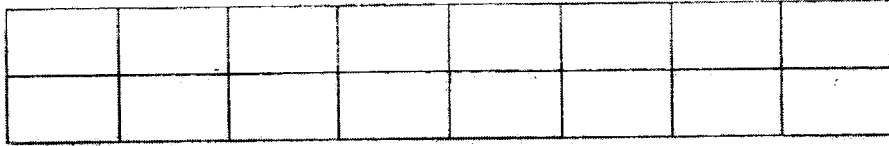



**Section C : Long-Answer / Structured Questions**

For questions 41 to 45, show your working clearly in the space below each question and write your answers in the spaces provided.

---

- 41 Julie collected 1480 stickers. Stephanie collected 288 stickers more than Julie.
- (a) How many stickers did Stephanie collect?
- (b) How many stickers did the two girls collect altogether?

Ans: (a) \_\_\_\_\_

(b) \_\_\_\_\_

---

- 42 Mrs Chandra bought 9 boxes of cupcakes. Each box contained 28 cupcakes. She repacked the cupcakes equally into 4 large containers. How many cupcakes were there in each large container?

Ans: \_\_\_\_\_

---

- 43 Zan ran around his school during his PE lesson. He took 18 minutes to finish running one round.
- (a) How long would he take to finish running 5 rounds, given that he took the same amount of time for every round?
- (b) Zan completed his 5 rounds at 11.45 a.m. What time did he start running?

Ans: (a) \_\_\_\_\_

(b) \_\_\_\_\_

- 
- 44 Bottles of soft drinks are sold in cartons of three. Each carton cost \$7. Mr James has \$160. What is the greatest number of bottles of soft drinks he can buy?

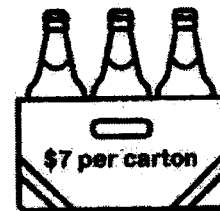

Ans: \_\_\_\_\_

---

- 45 A worker completely covered a square-shaped floor with identical tiles by using the tiling pattern below.

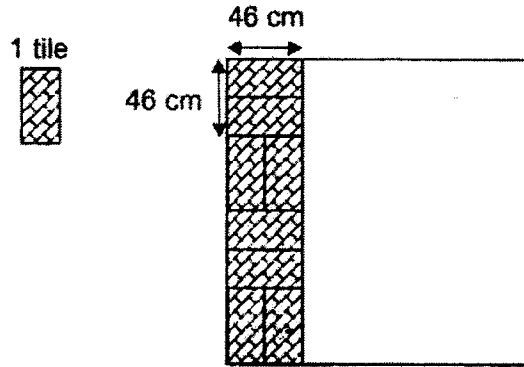

- (a) How many tiles did he use to completely cover the floor?  
 (b) What is the perimeter of the floor?

Ans: (a) \_\_\_\_\_

(b) \_\_\_\_\_

---

**End of Paper**

Have you checked your paper? ☺



## EXAM PAPER 2022

LEVEL : PRIMARY 3  
 SCHOOL : RED SWASTIKA SCHOOL  
 SUBJECT : MATHEMATICS  
 TERM : REVISION WORKSHEET 2

SECTION A

Q1	Q2	Q3	Q4	Q5	Q6	Q7
4	3	2	1	1	3	4
Q8	Q9	Q10	Q11	Q12	Q13	Q14
2	2	4	3	4	2	3
Q15	Q16	Q17	Q18	Q19	Q20	
3	4	3	3	3	4	

SECTION B

Q21. 4026

Q22. 1266

Q23. 1365

Q24. 4

Q25. False, True

Q26. 8308

Q27. 5

Q28. \$303

Q29. 210

Q30. 3 km 275 m

Q31. 2 l 25 ml

Q32. Box

Q33. Clip

Q34. 40 cm

Q35. \$56.80

Q36. 8 h

Q37.

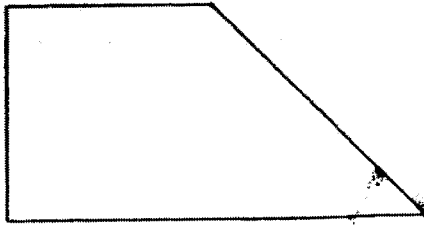
Q38.  $a = 5, b = 10$ Q39.  $\frac{2}{9}$ 

Q40.

**SECTION C**Q41. a)  $1408 + 288 = \underline{1768}$ b)  $1768 + 1480 = \underline{3248}$ Q42.  $28 \times 9 = 252$  $252 \div 4 = \underline{63}$ Q43. a)  $18 \times 5 = \underline{90}$ 

b) 10.15 am

Q44.  $160 \div 8 = \underline{22R6}$  $22 \times 3 = \underline{\$66}$ Q45. a)  $46 \times 4 = 172$  $172 \div 46 = 4$  $4 \times 8 = \underline{32}$ b)  $172 \times 4 = \underline{688 \text{ cm}}$  688 cm $8 \times 4 = 32$  $46 + 46 + 46 + 46 = 184$  $184 \times 4 = 736 \quad \text{END}$