



Temasek Primary School

Semestral Assessment 2

Primary Three

2015

No part of this paper may be reproduced for commercial purposes without the prior written permission of Temasek Primary School.

**SCIENCE
(Booklet A)**

Name: _____

Class: Primary 3 _____

Date: 28 October 2015

Parent's Signature: _____

60 Marks

Total Time for Booklet A and B: 1h 45 min

INSTRUCTIONS TO CANDIDATES

1. Write your name, class and register number in the spaces provided clearly.
2. Do not open this booklet until you are told to do so.
3. Follow all instructions carefully.
4. Answer all questions.
5. Shade your answers in the Optical Answer Sheet (OAS) provided.

1. The fish below has scales as its body covering. It swims in water and breathes through its gills.

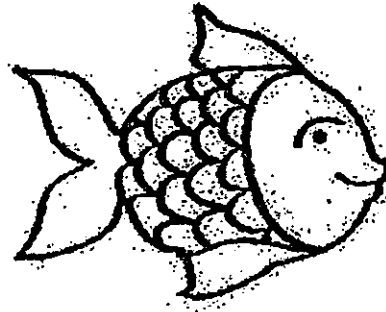

Which of the following is another characteristic of a fish?

- (1) It has 3 body parts.
 - (2) It feeds its young with milk.
 - (3) It lays eggs with a hard shell.
 - (4) It has fins and tail to enable it to swim.
2. Which of the following is not an example of a living thing showing a response?
- (1) The battery operated robot moves on its own.
 - (2) The dog barked when a stranger approached it.
 - (3) The leaf of a Venus Flytrap plant closes when a fly lands on it.
 - (4) The leaves of the mimosa plant close when you touch them.

3. Charlene observed an animal and wrote down the following descriptions as shown below.

A:	It has feelers.
B:	It has wings.
C:	It has 3 body parts.
D:	It has 3 pairs of legs.

Charlene's brother concluded that she was observing an insect. Which of the above descriptions helped him make his conclusion?

- (1) A only
 - (2) B only
 - (3) A and B only
 - (4) C and D only
4. Katelynn put some leaves in a box with holes and placed a butterfly at a particular stage of its life cycle into the box. She noted the changes in the mass of the leaves after several hours.

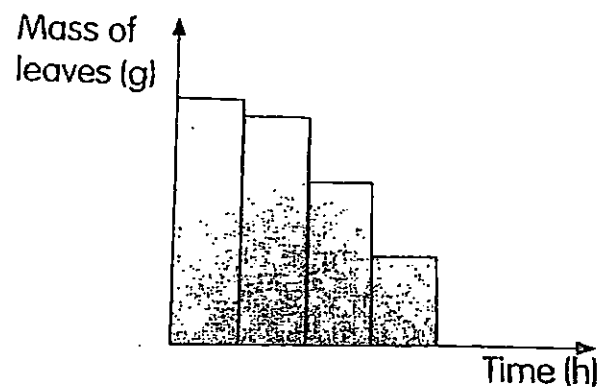

At which stage of the life cycle was the insect at?

- (1) adult
- (2) larva
- (3) pupa
- (4) egg

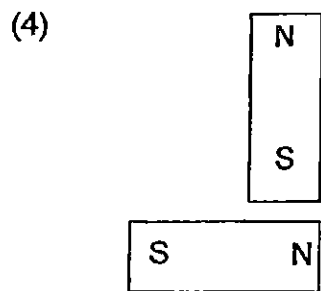
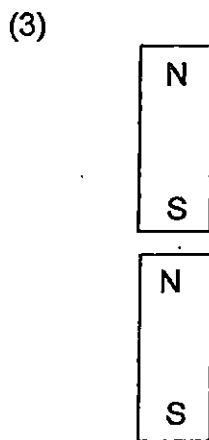
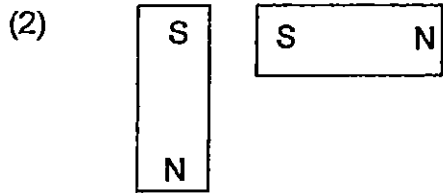
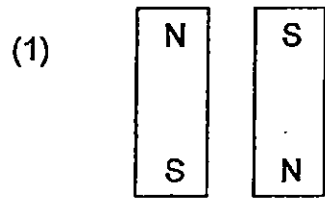

6. Mr Lim wanted to find out if grasshoppers need air to survive. Which of the following set-ups should he use?

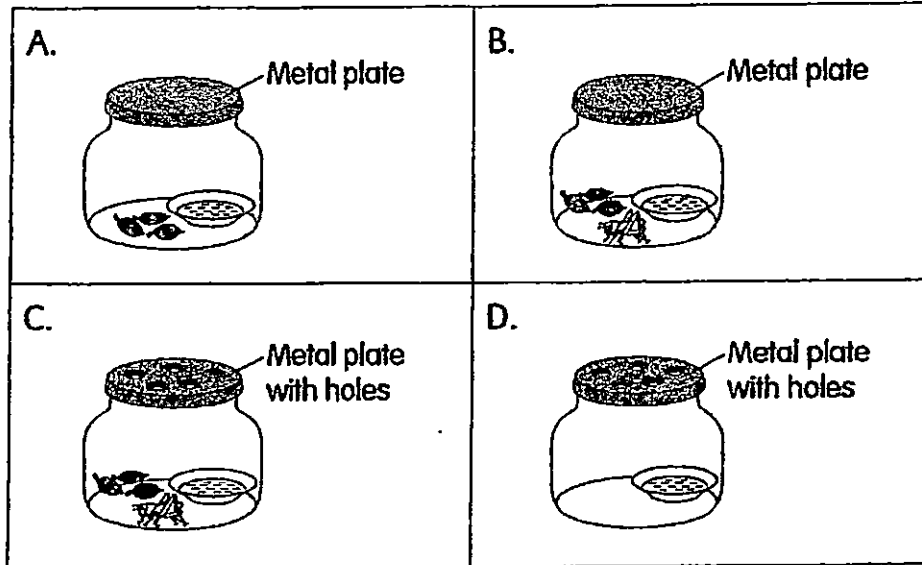

- (1) A and C
(2) B and C
(3) B and D
(4) C and D

7. The picture below shows a tiger chasing after a deer.



What characteristic of living things is the deer showing?

- (1) Living things can reproduce.
(2) Living things need air to survive.
(3) Living things respond to changes.
(4) Living things need food and water to survive.

8. A, B, C and D are various stages in the life cycle of a mealworm beetle.

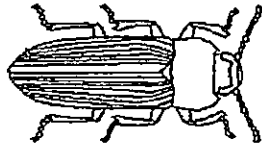

A



B

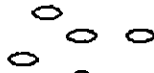

C



D

Which of the following correctly shows the sequence of the life cycle?

- (1) B → C → A → D
 - (2) A → B → C → D
 - (3) C → A → B → D
 - (4) D → A → C → B
9. Three slices of white bread were cut from the same loaf and put in different locations around the house. The same amount of water was added to each slice of white bread. The table below shows the conditions for the three slices of white bread.

White bread	Number of teaspoons of water added daily	Location where the white bread was placed
R	5	On the table
S	5	Dark cupboard
T	5	Refrigerator

On which slice(s) of bread would bread mould be most likely to appear after a few days?

- (1) R only
- (2) S only
- (3) R and S only
- (4) S and T only

10. Caden found an animal in the Eco-garden. He wanted to find out if the animal is a bird.

Which of the following observations can he make in order to determine if the animal is a bird?

- (1) Measure its weight.
- (2) Observe whether it has wings.
- (3) Observe whether it has a beak.
- (4) Observe whether it has any feelers.

11. Study the flow chart below.

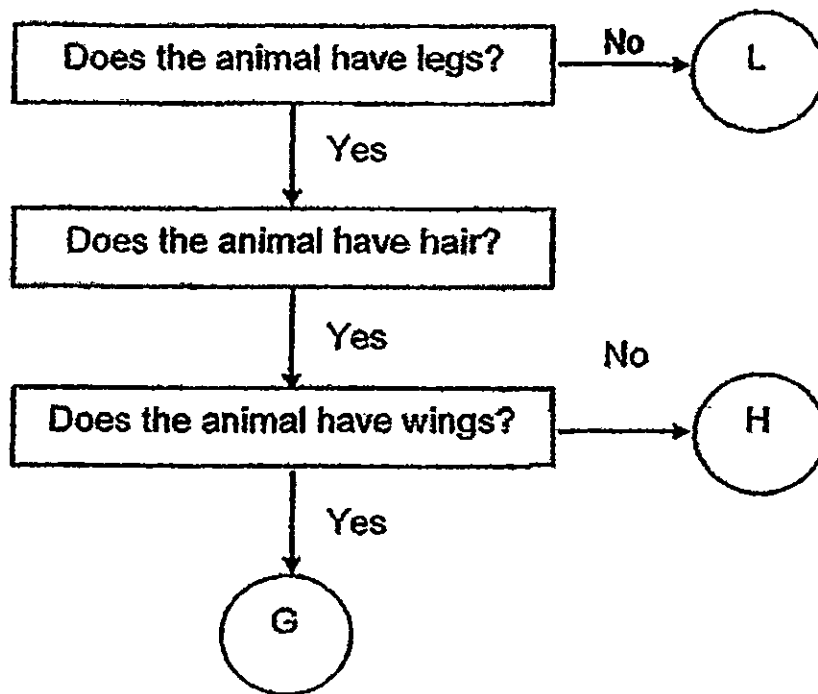

Which of the following best represent G, H and L?

	G	H	L
(1)	bat	monkey	fish
(2)	mosquito	monkey	fish
(3)	monkey	fish	bat
(4)	bat	mosquito	monkey

12. Standing at a height of 1m from the ground, Matthew dropped a 1 kg iron ball once on each of the three identical boxes made from different materials, P, Q and R. He then recorded the results of his experiment in the table below.

Material of box	P	Q	R
Appearance of the box after the experiment	Slightly damaged	Broke into a few pieces	No change

What can Matthew conclude about his experiment?

- (1) Material Q is the strongest material.
 - (2) Material P is stronger than material R.
 - (3) Material R is stronger than material P.
 - (4) Material Q and R are stronger than material P.
13. The diagram below shows a tent.

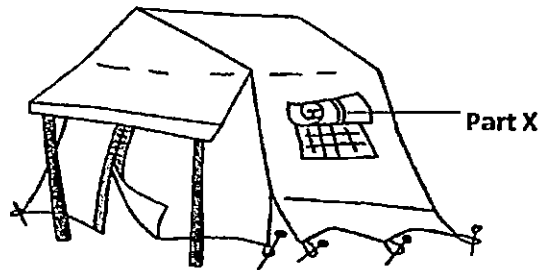

During a camp, Linda rolled up part X to allow cool air into the tent. Which of the following properties enabled her to roll up part X?

- (1) Flexibility
- (2) Strength
- (3) Waterproof
- (4) Ability to float in water

14. Andy had four temporary electromagnets. He wanted to find out if the number of batteries affects the strength of the electromagnets.

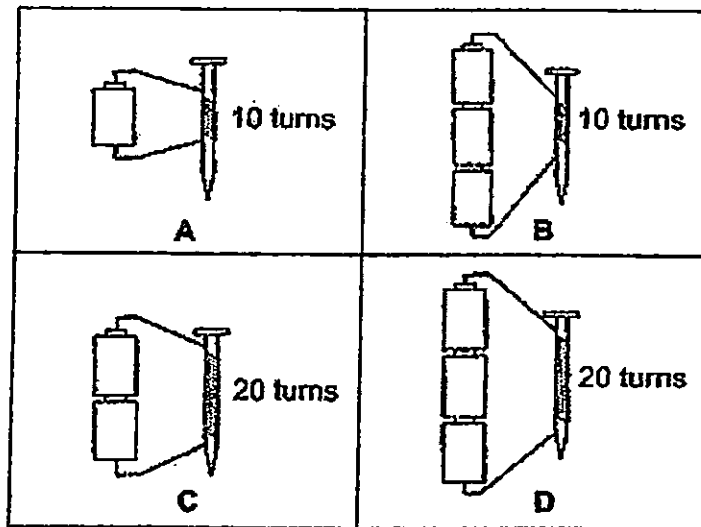

Which one of the following pairs of set-ups would be suitable for his experiment?

- (1) A and B
 - (2) A and D
 - (3) B and C
 - (4) B and D
15. Fahan tied a string to a bar magnet and freely suspended it.

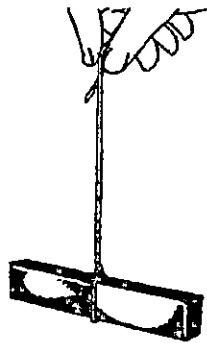

In which direction will the bar magnet point to when at rest?

- (1) north-south
- (2) north-west
- (3) east-west
- (4) south-east

16. Three identical iron rods are used to make temporary electromagnets P, Q and R.

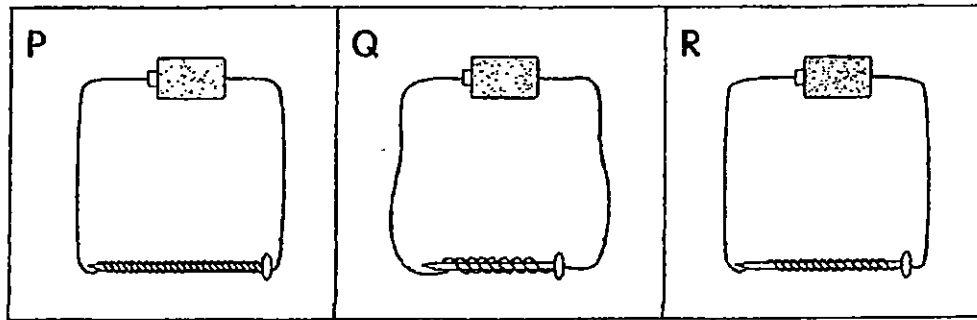

The electromagnets were arranged in ascending order of their magnetic strength, which of the following shows the correct arrangement?

- (1) P, R, Q
 - (2) R, P, Q
 - (3) Q, R, P
 - (4) Q, P, R
17. The diagram below shows the digestive system.

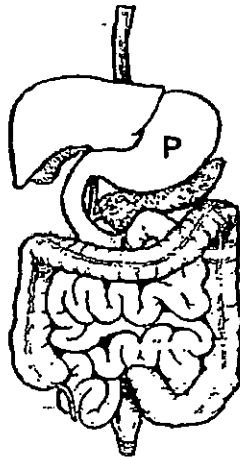

What is the state of the food that leaves P?

- (1) Undigested food
- (2) Fully digested food
- (3) Food in larger pieces
- (4) Partially digested food

18. Study the flowchart below.

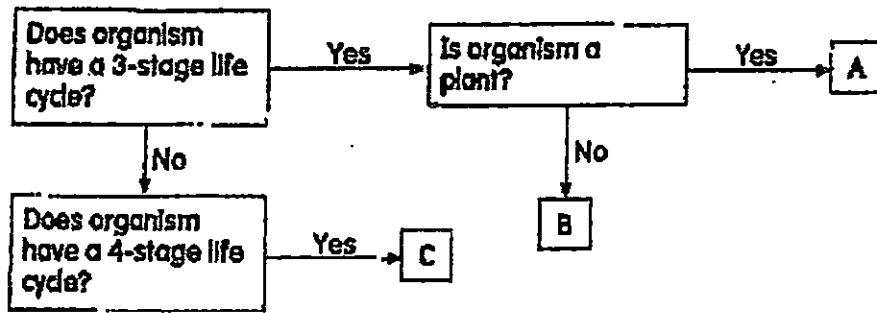

Which of the following cannot be placed in group A and C?

	Group A	Group C
(1)	mimosa	butterfly
(2)	bird nest fern	mealworm beetle
(3)	mango tree	mosquito
(4)	mushroom	cockroach

19. Study the diagram below carefully.

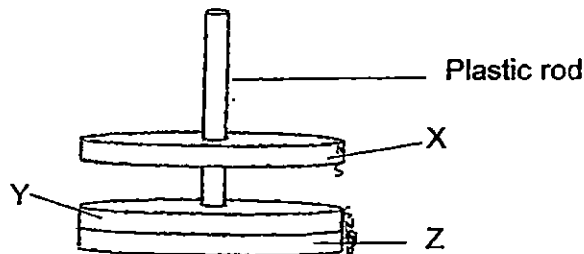

Which of the following statements are true?

- A: X is definitely a magnet.
- B: Y is definitely a magnet.
- C: Z is definitely a magnet.

- (1) A only
- (2) B only
- (3) A and B only
- (4) B and C only



fern

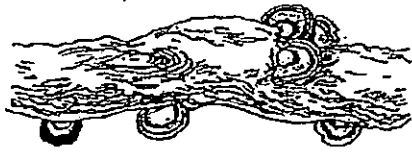

bracket fungi

Which of the following statements below correctly describe the similarities between them?

- A: Both reproduce by spores.
- B: Both are non-flowering plants.
- C: Both need air and water to survive.
- D: Both depend on decaying matter for food.

- (1) A and C only
- (2) A and B only
- (3) B and C only
- (4) C and D only

21. The graph below shows the number of days insects A and B spend in each stage of their life cycles.

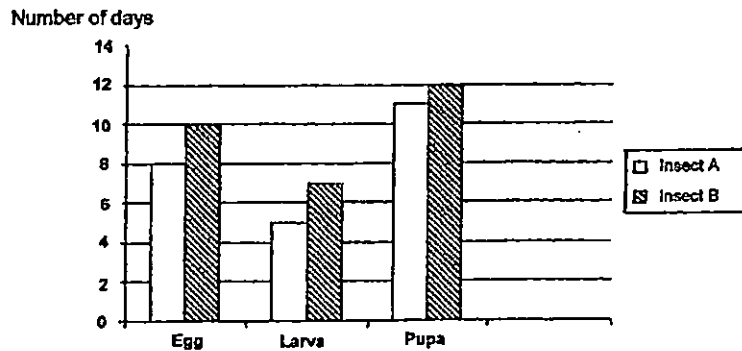

At which stage of their life cycles would insects A and B be on the 15th day after the eggs were laid?

	Insect A	Insect B
(1)	pupa	larva
(2)	larva	pupa
(3)	pupa	pupa
(4)	larva	larva

22. Siti placed some green beans in an air-tight container as shown below.

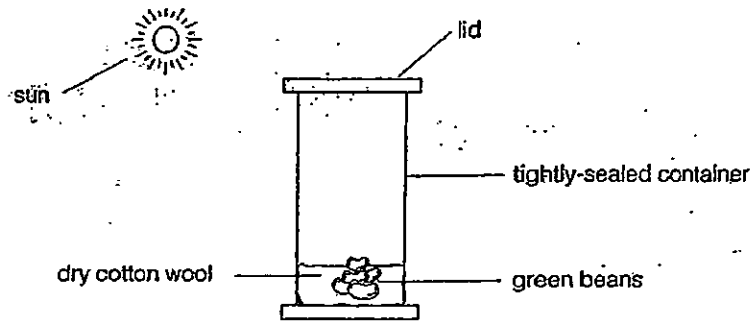

After one week, she observed that the seeds did not grow into a young plant. Which of the following is likely the reason for the observation?

- (1) There was no air.
- (2) There was no water.
- (3) There was no warmth.
- (4) There was not enough sunlight.

23. The life cycles of two insects are shown below.

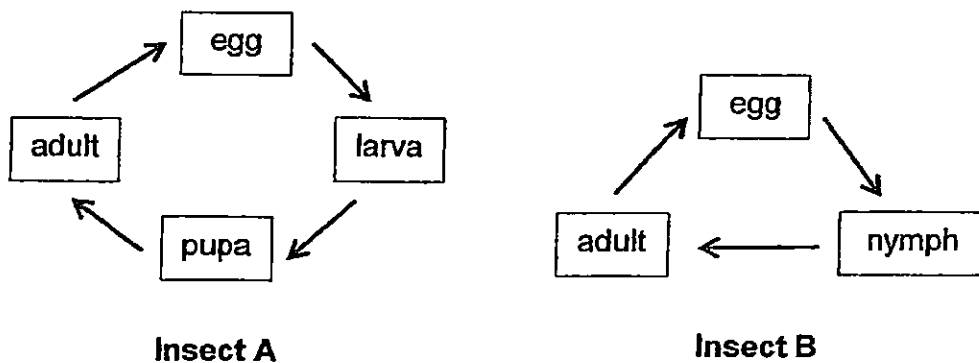

Based on the information given in the diagram, what conclusion can you make?

- (1) Insect A lays eggs in water but insect B does not.
- (2) The adult of insect A develop wings but not the adult of insect B.
- (3) Insect A is likely to be a butterfly and insect B is likely to be a cockroach.
- (4) Insect A takes a longer time than insect B to develop from an egg to an adult.

24. Study the classification table below carefully.

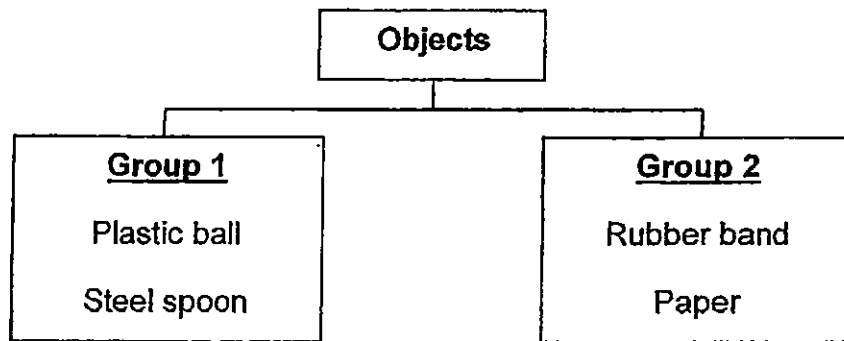

Noah wrote down a few ways to classify the objects as shown below.

- A: Whether they are flexible or not
- B: Whether they are waterproof or not
- C: Whether they are transparent or not
- D: Whether they are made from natural or man made materials

Which of the above statements is/are the correct way(s) in which the objects are classified?

- (1) A only
- (2) A and D only
- (3) B, C and D only
- (4) A, B, C and D

25. Elyssa conducted an experiment to find out the properties of object P. The table below shows her actions and observations.

Elyssa's Action	Observations
Dropped object P on the floor	Object P changed its shape but did not break
Make object P into different shapes	Object P changed its shape easily

Which of the following objects best represents object P?

- (1) Metal water bottle
- (2) Wooden stick
- (3) Glass bottle
- (4) Plasticine.

26. Tasha set up an experiment using 4 similar magnets A, B, C and D with different magnetic strength hanging from a pole at different heights. She then placed some thumb tacks below the magnets.

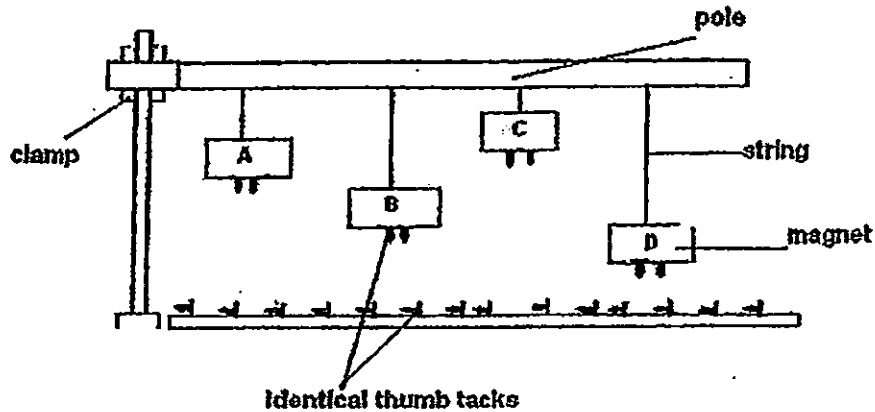

Based on the diagram, which magnet has the greatest magnetic strength?

- (1) A
 - (2) B
 - (3) C
 - (4) D
27. During a class discussion, four boys made different statements about the digestive system.

Andy: Saliva helps to digest the food we eat.

Benny: Only the small intestine helps to digest the food we eat.

Josh: The large intestine absorbs water from the undigested food.

Chris: The small intestine absorbs water from the undigested food.

Whose statements about the digestive system are correct?

- (1) Andy and Josh only
- (2) Andy and Chris only
- (3) Josh and Chris only
- (4) Benny and Chris only

28. Elijah conducted an experiment using a bar magnet and some paper clips. He marked four positions Q, R, S and T on the bar magnet and lowered it into a dish containing paper clips.



bar magnet

He then recorded the number of paper clips attracted to different positions in the table below.

Position	No. of paperclips the magnet attracted
Q	15
R	6
S	8
T	19

What can he conclude from his experiment?

- (1) Magnetism is strongest at position Q only.
- (2) Magnetism is the weakest at position S only.
- (3) Magnetism is strongest at positions Q and T.
- (4) Magnetism is the weakest at positions Q and T.

29. Fadzi took 3 different bar magnets, A, B and C. He put magnet A over a flame, hit magnet B with a hammer and threw magnet C on the floor several times.

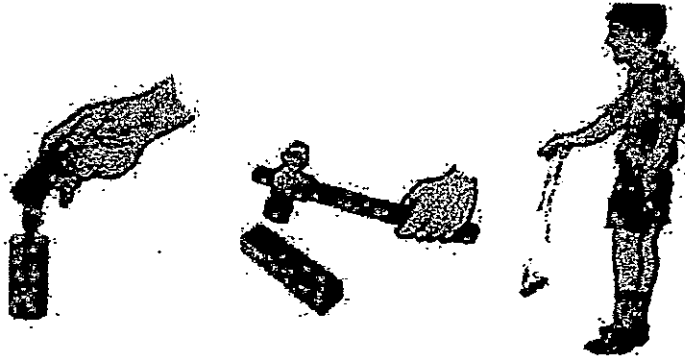

magnet A

magnet B

magnet C

What do you think will happen to the 3 bar magnets?

- (1) Nothing will happen to the bar magnets.
 - (2) Only bar magnet A will lose its magnetism.
 - (3) All the bar magnets will lose some of its magnetism.
 - (4) All the bar magnets will become stronger than before.
30. Siti wanted to find out if plants respond to sunlight.

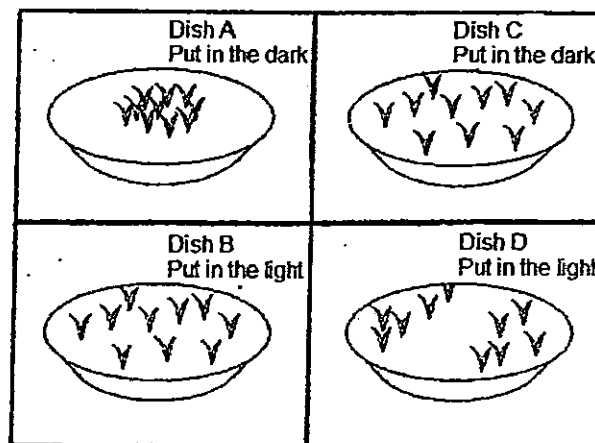

Which two set-ups should she choose?

- (1) Dish A and Dish D
- (2) Dish A and Dish C
- (3) Dish B and Dish C
- (4) Dish B and Dish D

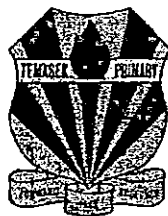

Temasek Primary School

Semestral Assessment 2

**Primary Three
2015**

No part of this paper may be reproduced for commercial purposes without the prior written permission of Temasek Primary School.

**SCIENCE
(Booklet B)**

Name: _____

Class: Primary 3 _____

Date: 28 October 2015

Parent's Signature: _____

Total Time for Booklet A and B: 1h 45 min

INSTRUCTIONS TO CANDIDATES

1. Write your name, class and register number in the spaces provided clearly.
2. Do not open this booklet until you are told to do so.
3. Follow all instructions carefully.
4. Answer all questions.
5. Write your answers in this booklet.

Paper	Marks	Scores
Booklet A	60	
Booklet B	40	
Total	100	

Write the answers to questions 31 to 44 in this booklet.

The number of marks allocated is shown in the brackets [] at the end of each question.

(40 marks)

31. Lynn grouped the animals below according to the way they reproduce.

Group 1	Group 2
monkey	duck
giraffe	turtle
guppy	snake

a. How do the animals in each of the groups reproduce? [2]

Group 1: _____

Group 2: _____

b. Name one group of animals that reproduces the same way as the animals in group 2. [1]

Score	3
-------	---

32. Nicholas set-up an experiment as shown below.

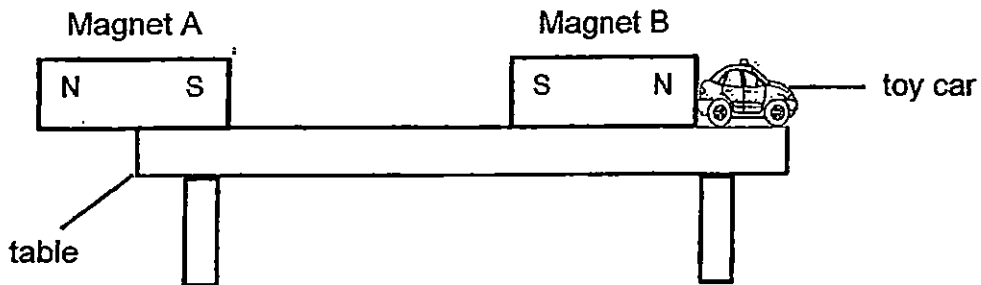

a. What will happen to the toy car when magnet A is brought closer to magnet B? [1]

b. Explain your answer in (a). [1]

c. Nicholas wants magnet B to move towards magnet A. What should Nicholas do to magnet B such that this will happen? [1]

Score	3
-------	---

33. Mr Lim carried out an experiment on 3 types of materials X, Y and Z of equal size and thickness as shown below.

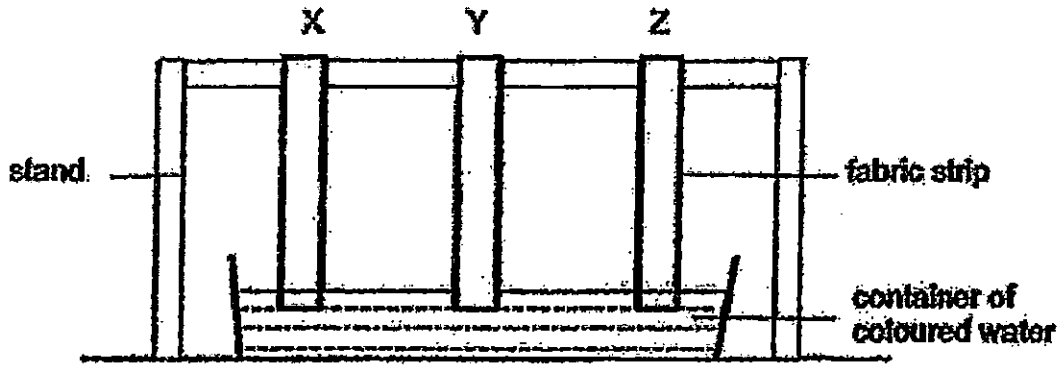

He hung each strip of material from the stand such that part of it is in the container of coloured water. He removed the strips after 10 minutes and recorded his observation in the diagram below.

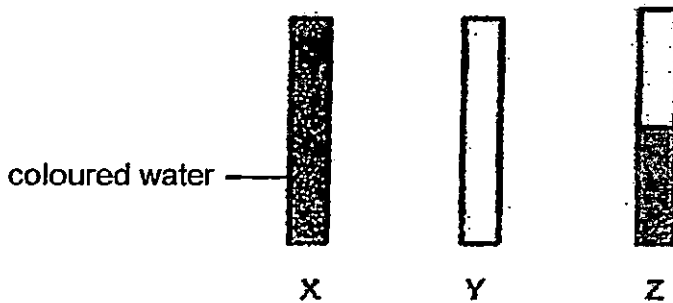

- a. Arrange the fabrics from the most absorbent to the least absorbent. [1]

- b. Mr Lim spilled a large amount of water on the table. Which material (X, Y or Z) would he use to clean up the water? Why? [1]

Score	2
-------	---

34. Aiman wanted to build a simple boat.

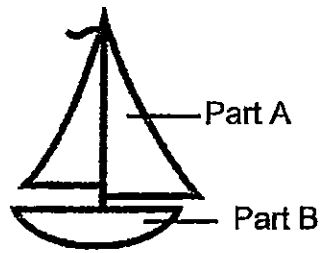

He sets up an experiment to find out which material would be most suitable for making part B.

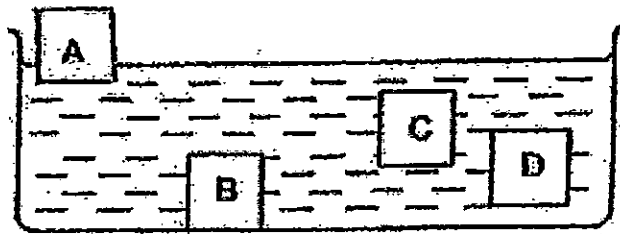

- a. Based on his experiment, which material A, B, C or D would be most suitable for making part B? Why? [1]

- b. Which property of material is he testing in this experiment? [1]

Score	2
-------	---

35. Ethan placed some damp soil in a shoe box made of thick cardboard that does not allow light to pass through. He placed ten green bean seeds into the soil and covered the box with its lid. A hole was cut out at one of the sides.

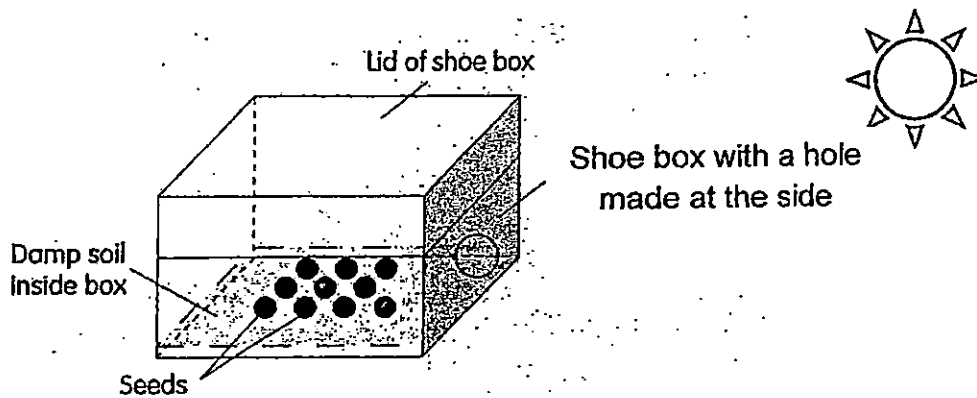

After 8 days, the young plants grew out of the hole of the shoe box.

- a. Why did the plants grow out of the hole? [1]

- b. State 2 characteristics of living things observed from his experiment. [2]

(i) _____

(ii) _____

Score	3
-------	---

36. Felicia made a model of the human digestive system as shown below.

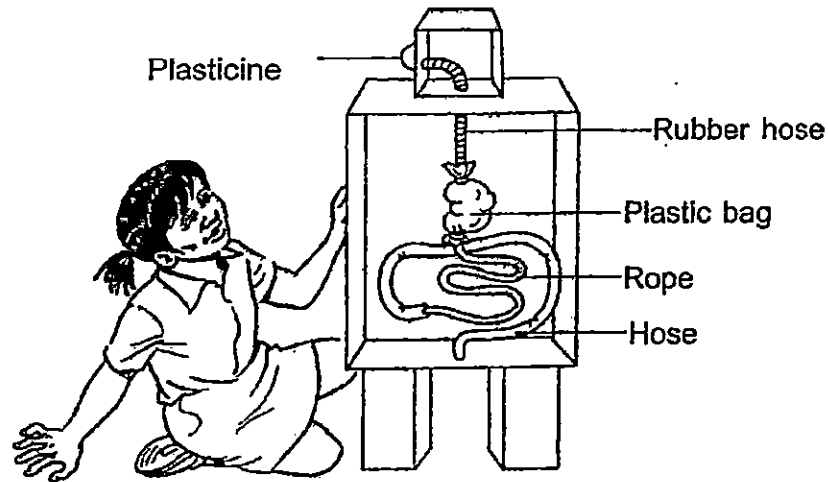

a. Identify each part of the human digestive system that represents the various parts of the model. [1]

	Parts of the model	Parts of human digestive system
	Plasticine	Mouth
(i)	Rubber hose	
(ii)	Plastic bag	

b. State the function of the gullet in the digestive system. [1]

c. State a difference in function between the small intestine and the large intestine. [2]

Score	4
-------	---

37. The diagram below shows an electromagnet.

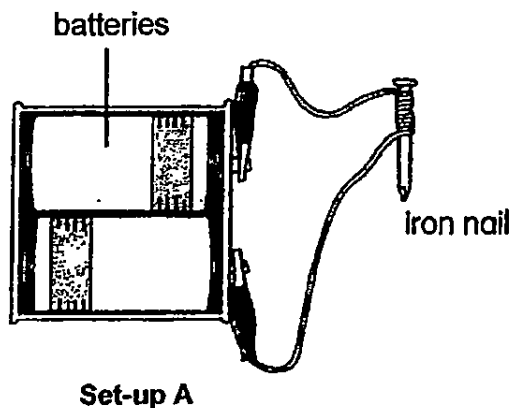

a. What will happen when some steel paper clips are placed near the iron nail? [1]

b. List two ways to increase the strength of an electromagnet. [2]

(i) _____

(ii) _____

Score	3
-------	---

38. The diagram below shows two different animals.

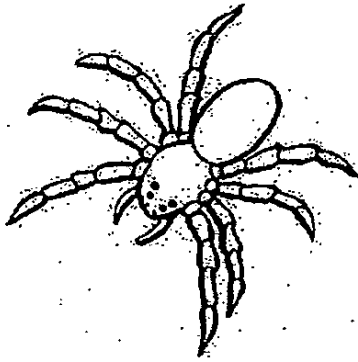

Animal A

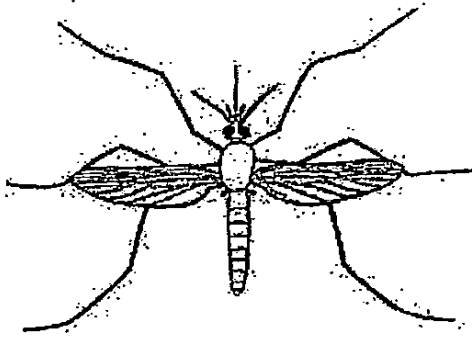

Animal B

a. Based on the diagrams above, state two characteristics of animal B. [2]

(i) _____

(ii) _____

b. Based on the diagrams above, does animal A and animal B belong to the same group of animals? Explain your answer. [1]

Score	3
-------	---

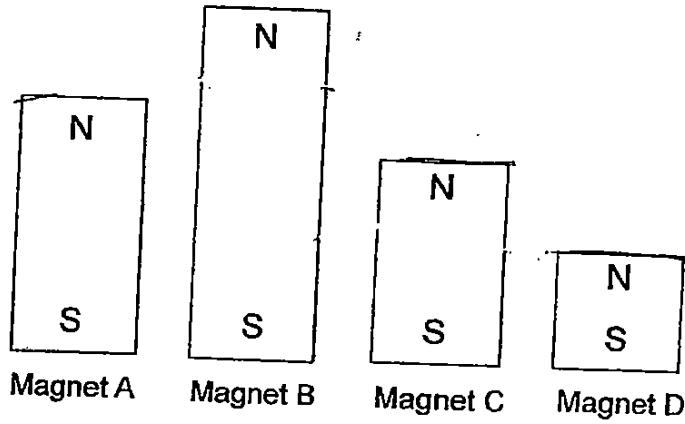

He placed the S-pole of each magnet at a distance of 5cm away from some paper clips and observed the number of paper clips attracted by each magnet. He recorded the results in the table below.

	Magnet A	Magnet B	Magnet C	Magnet D
Number of paper clips attracted	10	12	5	16

a. What was he trying to find out? [1]

b. From his experiment, what can he conclude about the strength of magnet D? [1]

Score	2
-------	---

- 40a. Draw and label the different stages in the life cycles of a mosquito and a cockroach in the boxes below. [2]
(You **do not** need to draw the pictures of the animals)

Life cycle of a mosquito	Life cycle of a cockroach

- 40b. State **two differences** between the **life cycles** of the two organisms you have drawn. [2]

First difference : _____

Second difference : _____

Score	4
-------	---

41. Charlotte set up an experiment as shown below. She provided food that can last for 5 days.

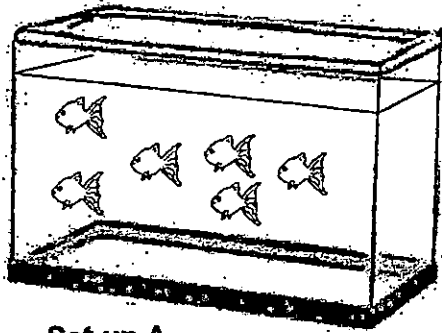

Set-up A

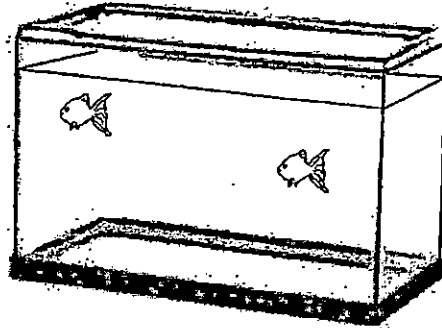

Set-up B

She measured and recorded the remaining amount of food left in the tank every day and recorded her findings in the table below.

Amount of remaining food

	Day 1	Day 2	Day 3	Day 4	Day 5
Set-up A	100g	80g	60g	40g	20g
Set-up B	100g	95g	90g	85g	80g

- a. Why is the amount of food in set-up B more than set-up A on the 5th day? [1]

- b. Charlotte continued feeding the fish in both tanks. The following week, there was an increase in the number of fish in set-up B even though she did not add in any new fish to the set-up.

What could be the possible reason for her observation? [1]

Score	2
-------	---

42. Sammy carried out an experiment as shown below.

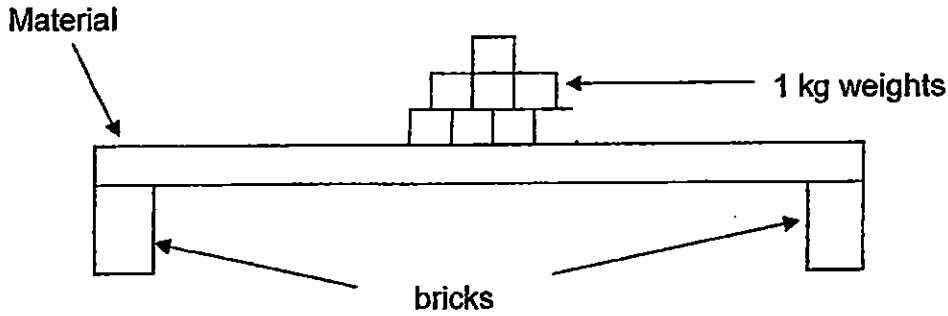

He placed different materials on two bricks and added weights onto each material until it finally broke. He then recorded his observations below.

Material	Amount of weight required to break the material/kg
E	15
F	5
G	20

- a. What property of the materials was Sammy trying to find out from his experiment? [1]

Sammy's brother chose material E to make a stool as shown below. However, Sammy explain that material E is not suitable.

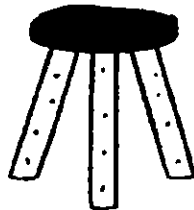

Information on stool:
Suitable for children below 4 years old and weighs not more than 20kg.

- b. Do you agree with Sammy? Explain your answer. [1]

Score	2
-------	---

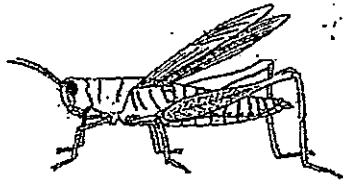

Grasshopper



Butterfly

a. State the number of stages in the life cycle of both the grasshopper and butterfly. [1]

grasshopper : _____ butterfly : _____

b. At which stage of its life cycle is the butterfly a pest to farmers? Why? [1]

c. Put a tick in the boxes below to state whether the statement is **true** or **false**. [2]

		True	False
(i)	The grasshopper has a nymph stage in its life cycle while the butterfly does not.		
(ii)	Butterflies lay their eggs on the underside of the leaves to prevent predators from eating them.		

Score	4
-------	---

44. Elsa carried out an experiment to find out how the amount of water affects the height of a seedling. She placed four similar seeds into four identical containers W, X, Y and Z.

She placed the containers near the window and water the containers with different amounts of water every day. She then measured the height of the seedlings after 5 days and recorded the measurements on a graph as shown below.

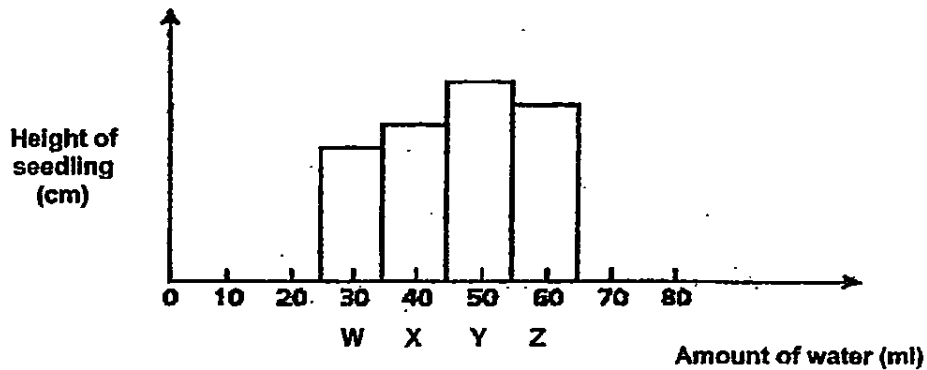

- a. In which container did the seed grow the tallest? [1]
-

- b. What would happen if Elsa stopped watering the seedlings for a week? [1]
-

- c. In order for her experiment to be successful, Elsa used the same type of seeds for her experiment. Explain why. [1]
-

Score	3
-------	---

End of the paper.



EXAM PAPER 2015

LEVEL : PRIMARY 3

SCHOOL : TEMASEK PRIMARY SCHOOL

SUBJECT : SCIENCE

TERM : SA2

Q 1	Q 2	Q 3	Q 4	Q 5	Q 6	Q 7	Q 8	Q 9	Q 10
4	1	4	2	2	2	3	4	3	3
Q 11	Q 12	Q 13	Q 14	Q 15	Q 16	Q 17	Q 18	Q 19	Q 20
1	3	1	1	1	3	4	4	3	1
Q 21	Q 22	Q 23	Q 24	Q 25	Q 26	Q 27	Q 28	Q 29	Q 30
1	2	3	2	4	3	1	3	3	3

Q31a. Group 1 : Give birth Group 2: Lays eggs

Q31b. Fish Q32a. The toy car will drop off the table.

Q32b. Magnet A and B are facing each other with the like poles, so when A comes forward both repel each other.

Q32c. Turn magnet B such that the north pole is facing the south pole of magnet A.

Q33a. X, Z, Y Q33b. X. It absorb the most water.

Q34a. A. It floats on water.

Q34b. He is testing if the material will float on water.

Q35a. They are growing towards the sunlight.

Q35b. (i) Living things can respond to changes. (ii) Living things can grow

Q36a. (i) gullet (ii) stomach

Q36b. The gullet brings the food down to the stomach.

Q36c. The small intestine absorb the digested food but the large intestine absorb the water.

Q37a. It will be attracted. Q37b. (i) Add more wire. (ii) Add more batteries.

Q38a. (i) It has 3 pair of legs. (ii) It has 3 body parts.

Q38b. No. A has 4 pairs of legs but B has 3 pairs.

Q39a. He was trying to find out if the size of the magnet affect its strength.

Q39b. It is the strongest.

Q40a. Life cycle of a cockroach → egg → nymph → adult

Q40b. First difference: The mosquito has a larva and pupa stage but the cockroach has nymph stage.

Q40b. Second difference: The cockroach lays eggs on land but the mosquito lays eggs in water.

Q41a. Set up A has more fish in set up B.

Q41b. In Set up B, the fish in the tank reproduce.

Q42a. The strength of the material.

Q42b. Yes. Material E cannot withstand weight more than 15kg.

Q43a. Grasshopper: 3 stages butterfly : 4 stages

Q43b. The larva. The larva of the butterfly will eat the leaves of the crop.

Q43c (i) TRUE (ii) TRUE

Q44a. Y. Q44b. The seedling will die.

Q44c. Different seeds germinate in different rate.