

Pei Chun Public School
Semestral Assessment 2 - 2011
Science
Primary 3

Name : _____ () Date : 1 November 2011

Class : Pr. 3 ()

Science Teacher : _____

Time : 1h 30 min

Section A (25 × 2 marks)

For questions 1 to 25, choose the most suitable answer and shade its number (1, 2, 3 or 4) on the Optical Answer Sheet (OAS) provided.

1. Look at the items and study the table below.



magazine



rabbit



marble



rose plant

Which of the following is correct?

	magazine	rabbit	marble	rose plant
(1)	non-living thing	living thing	non-living thing	living thing
(2)	non-living thing	living thing	living thing _x	non-living thing
(3)	living thing	non-living thing	non-living thing	living thing
(4)	living thing	living thing	living thing	non-living thing

()

2. Study the flowchart below.

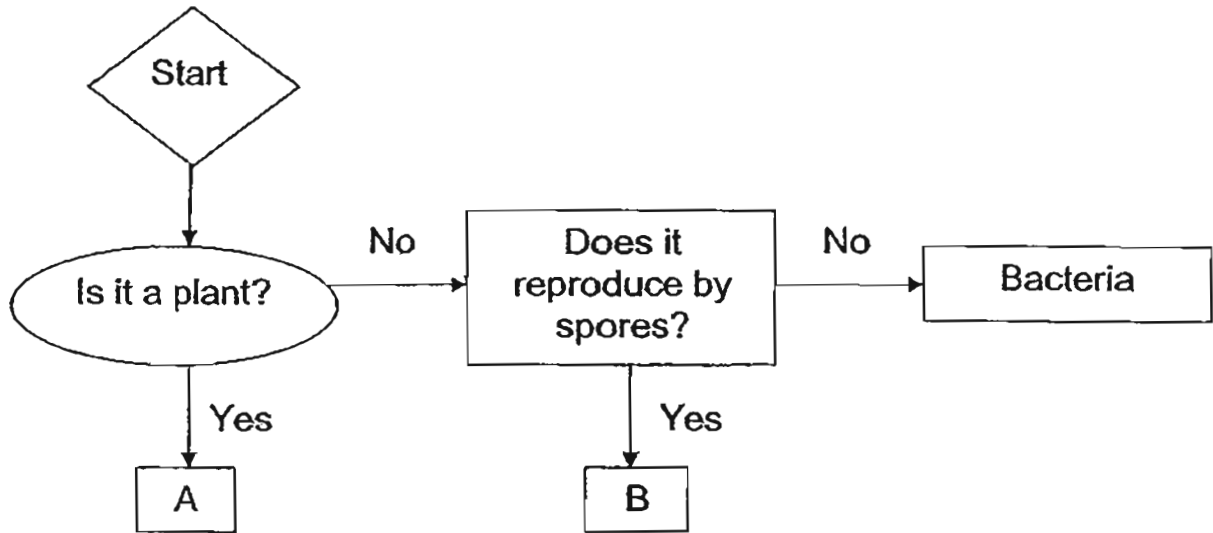

Which of the following best represents A and B?

	A	B
(1)	Moss	Bird's Nest Fern
(2)	Orchid	Bird's Nest Fern
(3)	Moss	Toadstool
(4)	Toadstool	Orchid

()

3. The diagram shows the stages in a life of a frog.

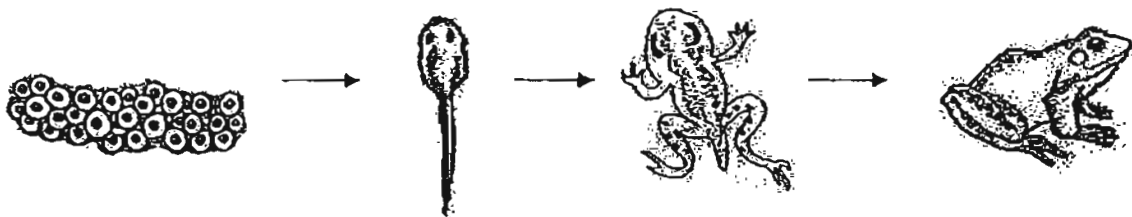

The diagram above shows that living things _____.

- (1) die
- (2) grow
- (3) can move
- (4) respond to changes around them

()

4. Look at the things given.



cat



moving toy robot

Which of these statements is / are definitely true about them?

A : They are living things.

B : They need air, food and water.

C : They can move from place to place.

(1) A only

(2) C only

(3) A and C only

(4) B and C only

()

5. Rahim placed four different things, A, B, C and D, into four tanks. The tanks had lids with holes in them. He then placed 500 g of food and some water in each tank. At the end of three days he recorded the amount of food left in each tank.

Thing	Amount of food left in each tank (g)
A	10
B	315
C	200
D	500

Which of the four things, A, B, C or D, is a non-living thing?

(1) A

(2) B

(3) C

(4) D

()

6. Study the information given.

Thing	Can reproduce	Can grow	Able to move from place to place	Needs water
K	No	No	No	No
L	No	No	Yes	Yes
M	Yes	Yes	No	Yes

Which statement accurately describes the things above?

- (1) L and M are living things.
- (2) K and M are living things.
- (3) K and L are non-living things.
- (4) K, L and M are all non-living things. ()

7. The diagram below shows a plant.

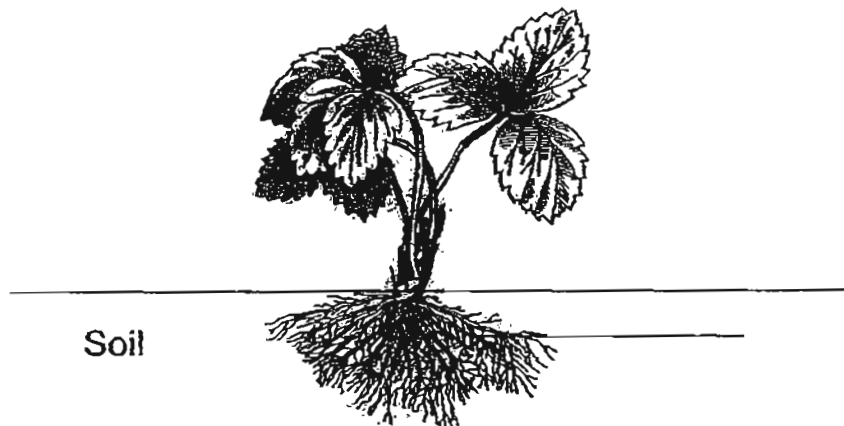





What is/are the main function(s) of part X?









- A : To take in air from the surroundings.
- B : To hold the plant firmly to the ground.
- C : To take in water and minerals from the soil.
- D : To support the branches so that the leaves can get sunlight.

- (1) C only
- (2) B and C only
- (3) A, C and D only
- (4) A, B and D only ()

8. Study the classification table below.

Plants	
Group X	Group Y
	
	

Tammy found two plants in her garden that she can classify in Group X and Group Y. Which are the two possible plants she found?

	Group X	Group Y
(1)		
(2)		
(3)		
(4)		

()

9. Sharon conducted an experiment using two similar plants. She placed each plant in a different location. She added an equal amount of water in each pot every day.

Plant A



placed in an
open field

Plant B



placed in a
dark room

After two weeks, she compared the colour of the leaves.

What was Sharon trying to find out?

She wanted to find out if plants need _____.

- (1) air to stay alive
- (2) soil to grow well
- (3) water to stay alive
- (4) sunlight to grow well

()

10. The following table shows information on three animals, X, Y and Z. A tick (✓) shows that the animal has the characteristic.

	Animals		
	X	Y	Z
Is it a mammal?	✓		✓
Does it have wings?		✓	✓
Can it fly?		✓	✓

Which of the animals in the table below correctly represents animals, X, Y and Z?

	X	Y	Z
(1)	whale	ostrich	butterfly
(2)	shark	bat	chicken
(3)	whale	chicken	bat
(4)	shark	butterfly	ostrich

()

11. The diagram below shows two animals.



sparrow



emu

Based on the diagrams above, what is the similarity between them?

- (1) Both of them can fly.
- (2) They both have beaks.
- (3) The animals live in trees.
- (4) They have thick fur on their bodies

()

12. Study the table below carefully.

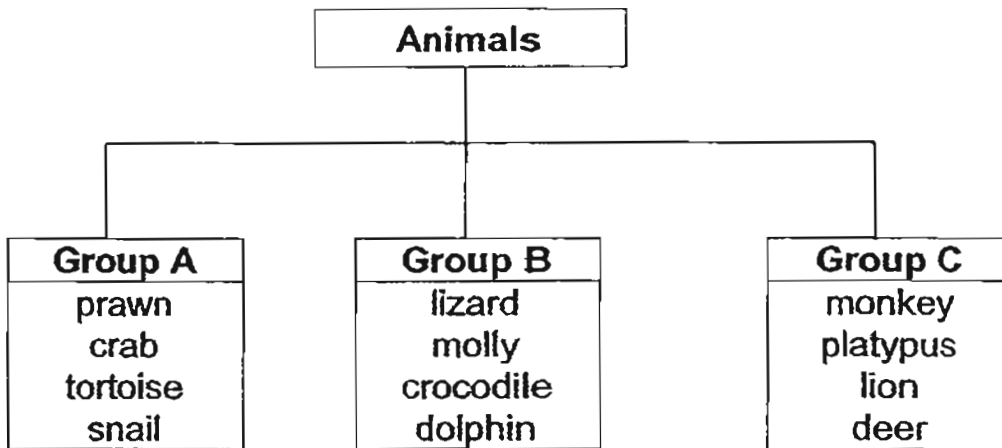

Which one of the animals is classified wrongly?

- (1) dolphin
- (2) tortoise
- (3) platypus
- (4) monkey

()

13. Which of the following items will most likely have fungi growing on it after a week?

(1)



a slice of toasted bread in sealed bag

(2)



dry wooden pencil

(3)

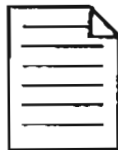

clean, dry writing paper

(4)



a block of cheese left on the table

()

14. Baoqi had two similar dishes of jelly, dish A and dish B. She wanted to find out if mould grows better in certain places. She rubbed her fingers onto her dirty shirt and made fingerprints on the jelly in each dish. She left the dishes in two places.

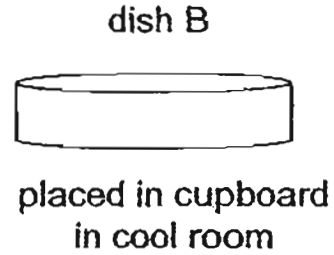
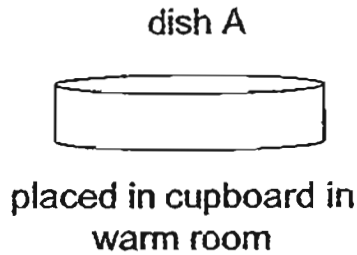

Which graph correctly represents the mould growth on both dishes after two weeks?

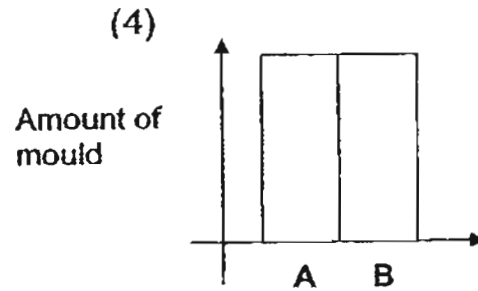
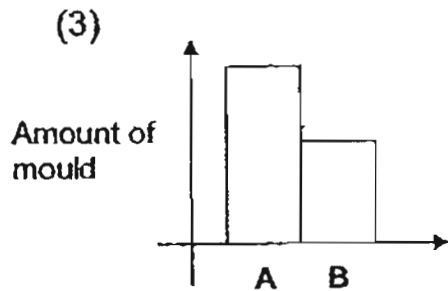
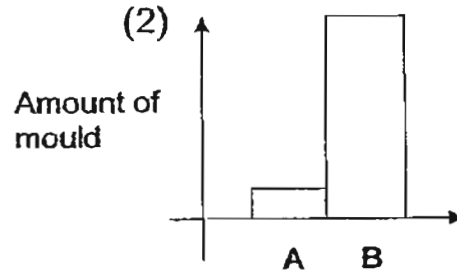
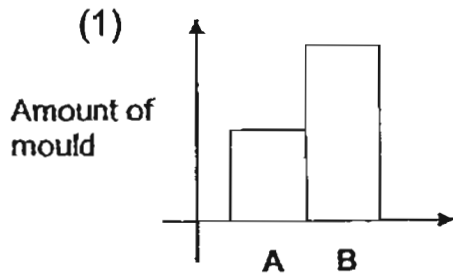

()

15. The classification table below shows the properties of materials, P, Q, R and S.

	Strong	Flexible	Waterproof
P		✓	✓
Q	✓		
R	✓		✓
S	✓	✓	✓

The diagram below shows a closed umbrella and the frame of the umbrella when it is opened.



umbrella

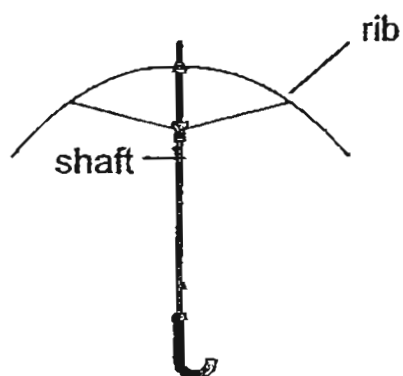

frame of umbrella

Which material would be most suitable for making the umbrella rib and shaft?

	Rib	Shaft
(1)	P	S
(2)	S	R
(3)	R	Q
(4)	Q	R

()

16. Chandra had two similar sized balls that were made of Material X and Material Y. He was given the table of information below.



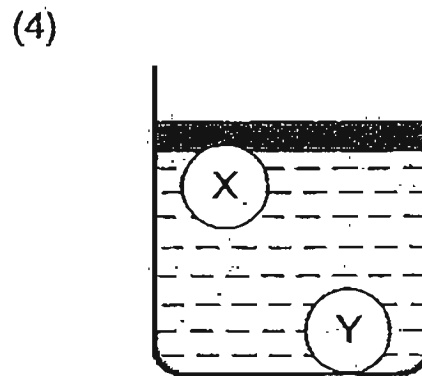
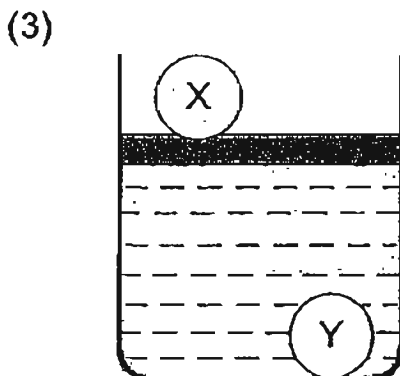
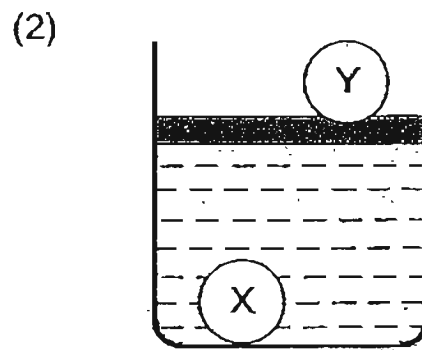
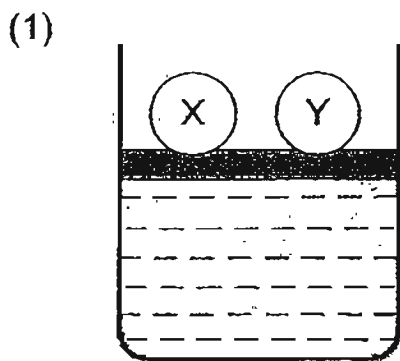
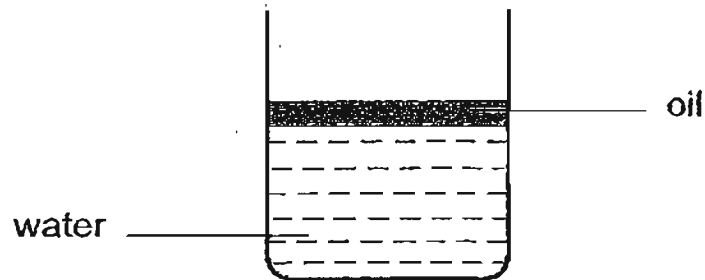

	Sink in water	Float on oil
Ball made of Material X		✓
Ball made of Material Y	✓	

Given that oil will always float on water, which of the following diagrams correctly shows how the two balls will look like when dropped into a beaker with both oil and water?



()

17. The table below shows the uses and properties of four types of materials. Which of the materials has been wrongly matched to its uses and reasons provided for choosing it?

Type of Material	Common Uses	Reasons for choosing the material
(1) Metal	Drink cans, food cans 	<ul style="list-style-type: none"> • strong • cannot see through • hard
(2) Glass	Sauce bottles 	<ul style="list-style-type: none"> • hard • can see through
(3) Fabric	Cotton T-shirt, socks 	<ul style="list-style-type: none"> • light • waterproof • cannot be stretched
(4) Plastic	Lunchbox, raincoats 	<ul style="list-style-type: none"> • light • waterproof

()

18. Some objects were put into two groups.

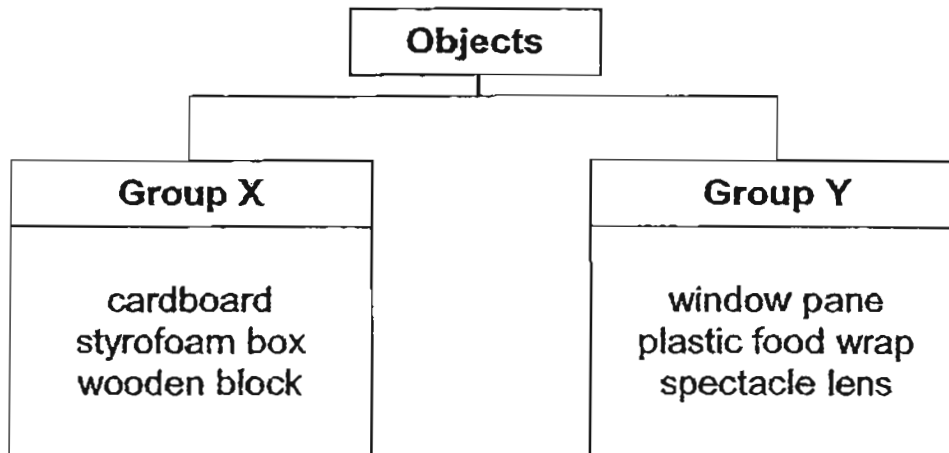

Which of the following is a possible heading for Group X and Group Y?

	Group X	Group Y
(1)	Waterproof	Not waterproof
(2)	Cannot see through	Can see through
(3)	Hard	Soft
(4)	Elastic	Not elastic

()

19. The diagram below shows a U-shaped magnet.

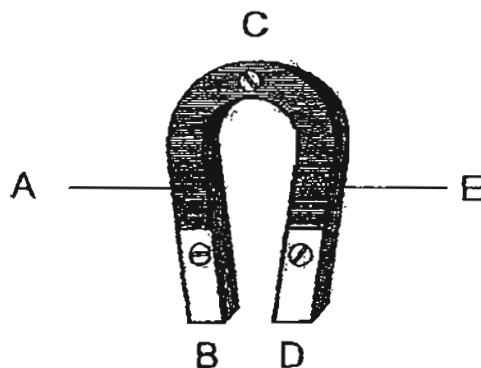

Which parts of the magnet can attract the most iron filings?

- (1) B and D only
- (2) C and D only
- (3) A and E only
- (4) B and C only

()

20. Ting Kai puts a piece of magnet near object A. The South pole of the magnet attracts both ends of object A.

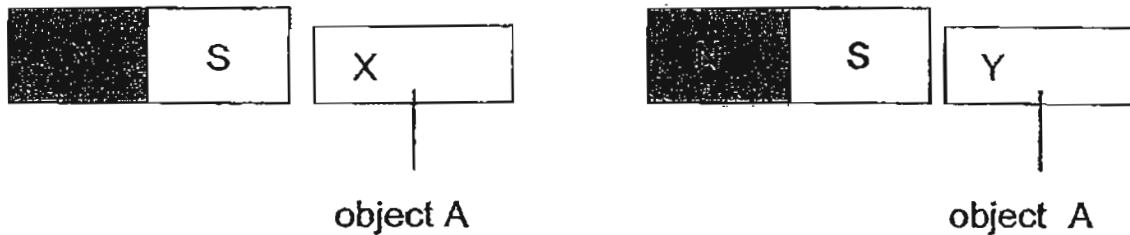

Which of the following statements are true?

- A: Object A is a magnet.
- B: Object A is made of magnetic material.
- C: The North pole of the magnet will attract end X of Object A.
- D: The North pole of the magnet will attract end Y of Object A.

- (1) B and D only
- (2) A and C only
- (3) A, C and D only
- (4) B, C and D only

()

21. Which of the following is **NOT** a use of magnets?

- (1) Opening a key lock
- (2) Keeping the refrigerator door tightly closed
- (3) Showing directions in compasses to hikers
- (4) Storing necessary information in ATM cards

()

22. Alice arranged four bar magnets as shown in the diagram below. All the magnets are attracted to the magnet(s) next to it.

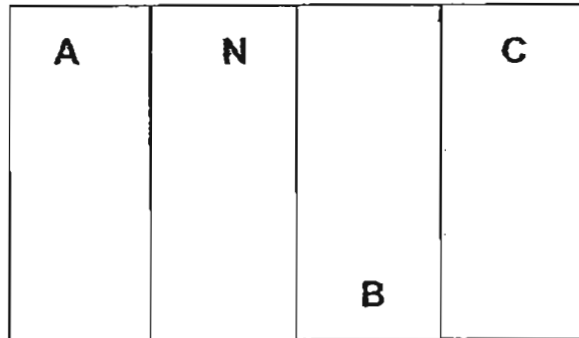

If N is the North-pole of the magnet, what could poles A, B and C be?

	A	B	C
(1)	South Pole	North Pole	South Pole
(2)	North Pole	North Pole	South Pole
(3)	South Pole	North Pole	North Pole
(4)	North Pole	South Pole	South Pole

()

23. The diagram below shows a rambutan fruit.



It is developed from a _____.

- (1) leaf
- (2) stem
- (3) roots
- (4) flower

()

24. Study the diagram of the human digestive system.

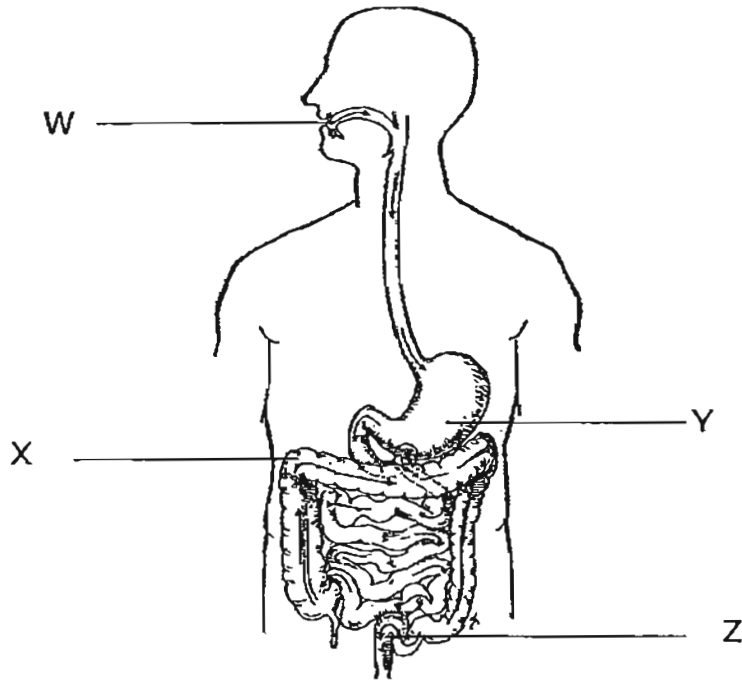

Peter grinded some meat in a mixer. In which part, W, X, Y or Z would a similar process take place?

- (1) W
- (2) X
- (3) Y
- (4) Z

()

25. Which of the following shows correctly where digestion begins and ends?

	Begins in the...	Ends in the ...
(1)	gullet	stomach
(2)	mouth	small intestine
(3)	gullet	small intestine
(4)	mouth	stomach

()

For Questions 26 to 30, please refer to Booklet K. — NO QTH
NO ANS

End of Section A

Pei Chun Public School
Semestral Assessment 2 – 2011
Science
Primary 3

Name: _____ ()

Class: Pr. 3 ()

Date: 1 November 2011

Time: 1 h 30 min

Science Teacher: _____

Parent's signature: _____

Section A	60
Section B	30
Booklet K (excludes MCQs)	10
Total	100

Section B (30 marks)

For questions 31 to 40, write your answers in the spaces provided.

31. Gopal was given a diagram with the following shapes.

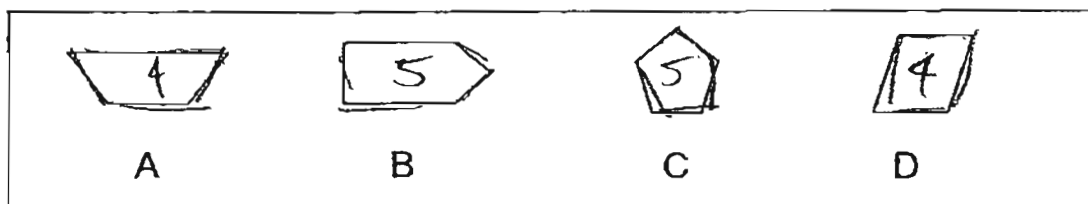

Classify these shapes into two equal groups. Provide a suitable heading for each group. (2 m)

<p>_____</p> <p>_____</p>	<p>_____</p> <p>_____</p>

32. Thomas carried out an experiment. He watered the plant before leaving it in a sealed cardboard box as shown below.

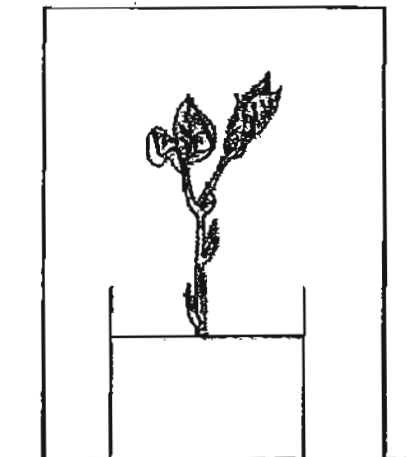

- a) He poked a hole in the cardboard box. After two days, he observed that the plant grew towards one side.

On the diagram below, draw an 'X' to show the position of the hole made by Thomas. (1 m)

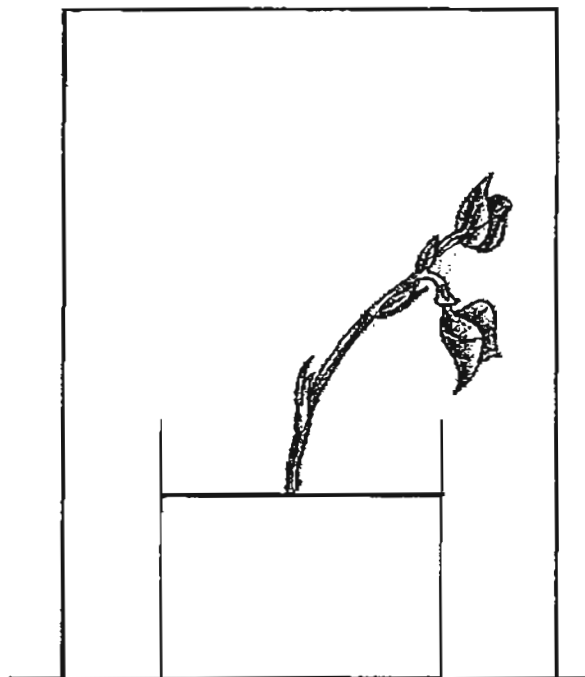

- b) Which of the following best explains why the plant grew towards one side? Put a tick (✓) in the correct box. (1 m)

The plant needs air.	
The plant needs space.	
The plant needs sunlight.	

c) Study the diagrams of the leaves.



Leaf A



Leaf B



What are the shapes and edges of the two leaves shown above?

(2 m)

	Shape of Leaf	Type of edge
Leaf A		
Leaf B		

33. Study the table carefully.

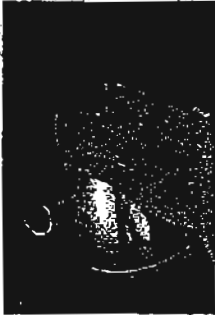
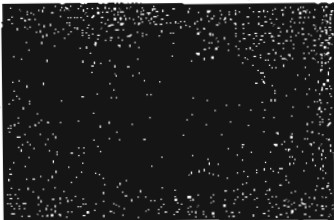
Put a tick (✓) in the box to indicate that the description given is a characteristic of a living thing. Put a (×) to indicate that the description is not a characteristic of a living thing. (3 m)

Description	
 a) Sally withdrew her hand when she touched a hot kettle.	
 b) A coconut tree being blown by the wind.	
 c) A turtle hides into its shell when it senses danger.	

d) Study the flowchart.

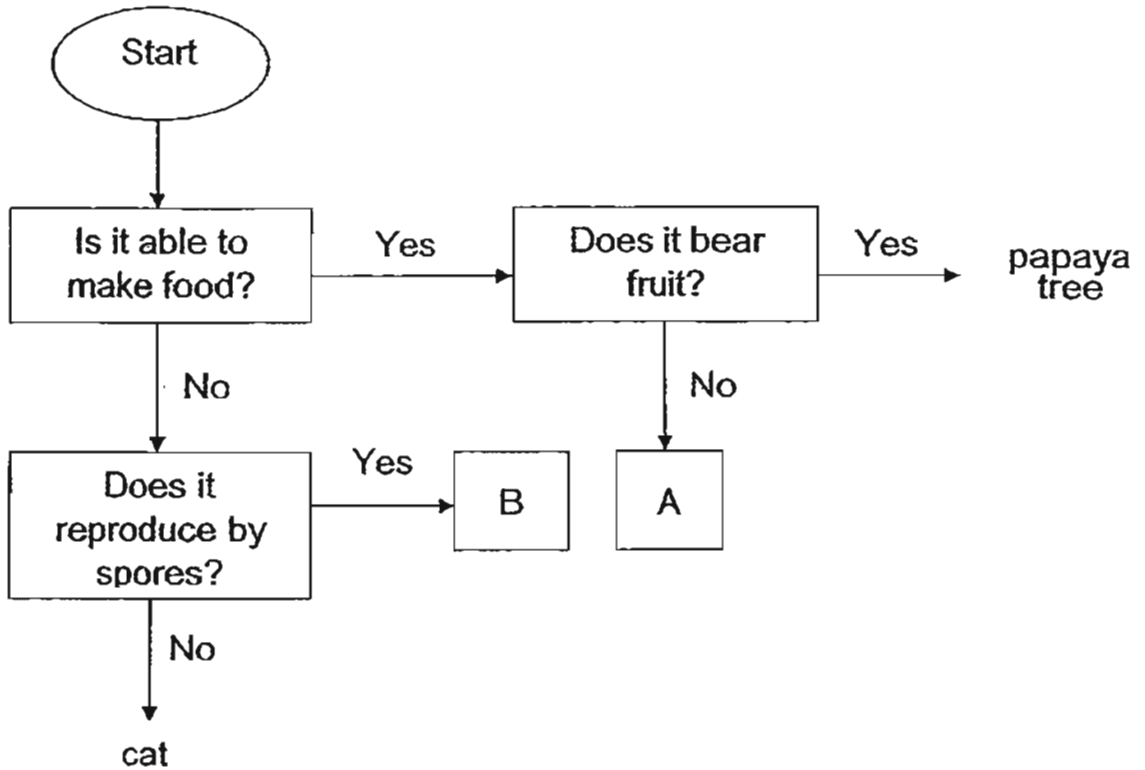

Which of the following organisms, A or B, could be a fern?
Give a reason for your answer.

(1 m)

34. Tommy wanted to carry some wet clothing home after his swimming lessons. He could not decide between the two bags below.

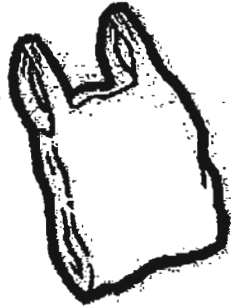

plastic bag



paper bag

a) Which bag should Tommy use? (1 m)

b) Give two reasons why he should use the bag in (a). (2 m)

Reason 1 :

Reason 2 :

35. The diagrams below show a goldfish and an ant.



goldfish

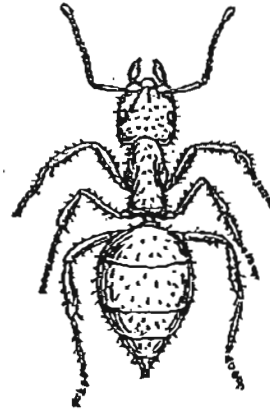

ant

- a) Compare the two animals. Decide if each statement is true or false. Put a tick (✓) in the appropriate box. (2 m)

	True	False
They have the same outer body covering		
They move the same way.		
They reproduce the same way.		
They both live in water.		

- b) There were two tanks, A and B. Each tank had two hamsters. The bar graph below shows the number of hamsters in each tank after three months. No new hamsters were added to the tank.

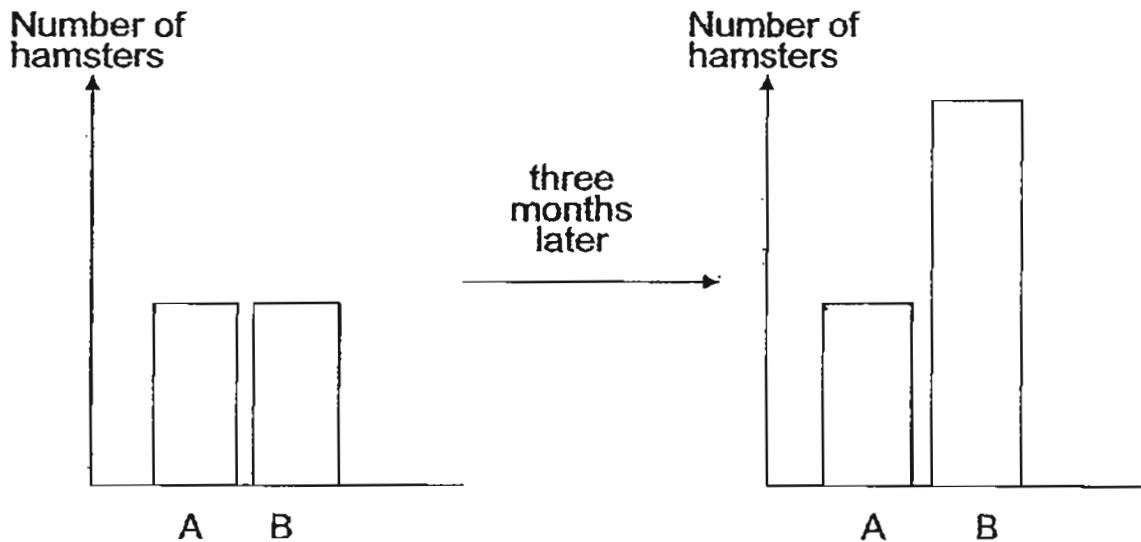

- i) Did the number of hamsters in Tank B increase, decrease or remain the same? (1 m)

- ii) Give a possible reason for your answer in (i). (1 m)

36. James had three oranges. He placed them in three separate tanks as shown. Each tank was covered with a lid that had holes in them. Tank A and Tank B were placed in dark cupboards, while Tank C was placed in a refrigerator.

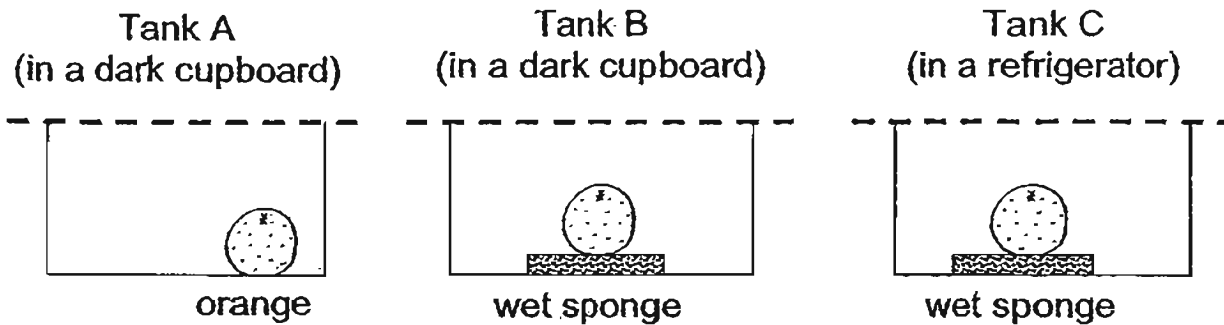

He left the oranges for 10 days. The table below shows what he observed.

Day	Tank A	Tank B	Tank C
1	No change	No change	No change
4	No change	A few black patches	No change
7	A few black patches	Dark green patches appear	No change
10	A few more black patches appear	Many more black and green patches appear	No change

a) Based on the information above, state which tank, A, B or C, did the orange have mould growing on it first. (1 m)

b) Based on the set-ups, name two conditions that encouraged the mould's growth to be faster on the orange you chose in (a). (1 m)

37. Meimei placed a strip of material W on two blocks as shown below. She added different number of bricks on the strip and measured the distance from the ground to the bottom of the strip. She wanted to test the number of bricks material W could support before breaking.

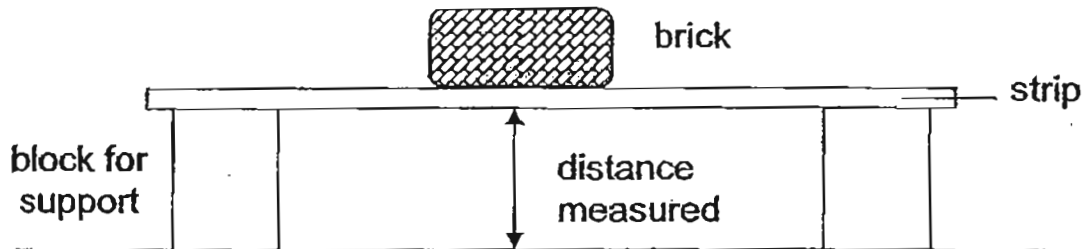

Using the same bricks, she repeated the experiment with the other strips made of material X and Y, one at a time. She recorded the results in the table below.

Number of bricks added to the bridge	Distance from bench to bottom of bridge (cm)		
	Material W	Material X	Material Y
0	50	50	50
1	50	45	40
2	50	broke	38
3	50	-	broke

- a) Which of these materials, W, X or Y, should Meimei use to make a bookshelf? (1 m)

- b) Give a reason for your answer in (a). (1 m)

- c) From the results above, state another property that materials W, X and Y were tested for. (1 m)

38. An experiment was conducted with three rods, Q, R and S.
A bar magnet was used to attract each end of the rods.

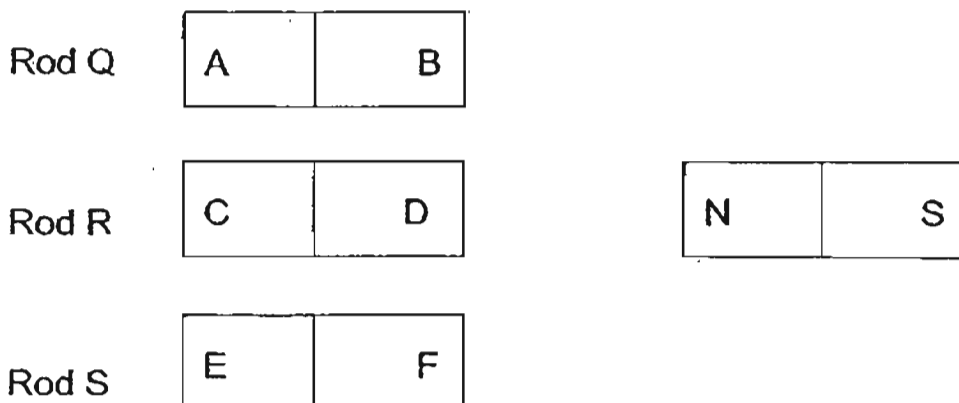

The results are as follows:

	End	Attracted by North pole	Repelled by North Pole	Neither attracted or repelled
Rod Q	A	✓		
	B	✓		
Rod R	C		✓	
	D	✓		
Rod S	E			✓
	F			✓

- a) Which rod, Q, R or S, was the magnet? (1 m)

- b) Explain for your answer in (a). (1 m)

- c) Suggest a material that Rod Q could be made of. (1 m)

39. The table below describes the movement of food through the human digestive system. However, the steps are not in correct order.

Complete the table by writing the numbers 2 to 7 in the boxes to show the correct order. Step 1 is provided for you. (3 m)

Steps	Order of steps
Digestive juices in the stomach mix with the food to break the food down.	
Waste is removed from the body.	
I take a bite of my sandwich. My teeth chew and grind the food into smaller pieces.	1
Undigested food passes into the large intestine.	
The digested food passes into the blood vessels.	
Digestion is completed in the small intestine.	
The food travels down the gullet into the stomach.	

40. A healthy plant was placed in the set-up shown below.

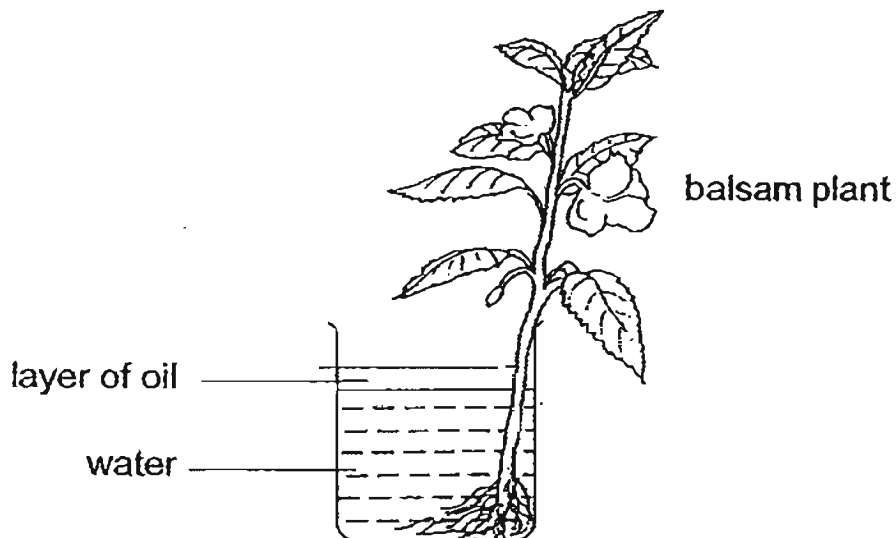

a) Would the water level in the beaker rise, fall or remain the same after two days? (1 m)

b) Give a reason for your answer in (a). (1 m)

For Questions 41–44, please refer to Booklet K. = NO EXH
= NO ANS

End of Section B

Set by: Miss Melissa Yap

Vetted by: P3 Science Committee teachers

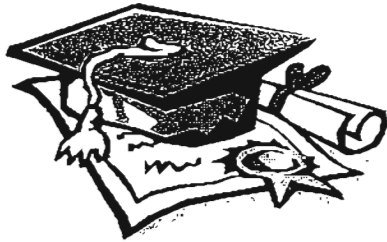

ANSWER SHEET

EXAM PAPER 2011

SCHOOL : PEI CHUN
SUBJECT : PRIMARY 3 SCIENCE

TERM : SA2

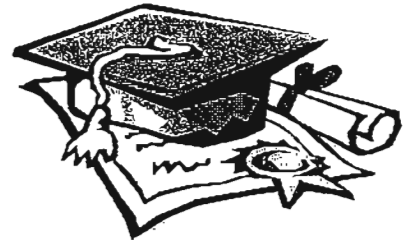

Q1	Q2	Q3	Q4	Q5	Q6	Q7	Q8	Q9	Q10	Q11	Q12	Q13	Q14	Q15	Q16	Q17
1	3	2	2	4	3	2	2	4	3	2	1	4	3	2	3	3

Q18	Q19	Q20	Q21	Q22	Q23	Q24	Q25
2	1	4	1	3	4	1	2

31) Four sides

A
D

Five sides

B
C

32)a)

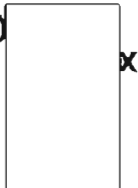

b) The plant needs sunlight.

c)

	Shape of Leaf	Type of edge
Leaf A	jagged-edge	jagged-edge
Leaf B	oval	entire-edge

33)a) ✓ b) X c) ✓

d) Organism A, fern is able to make food and bear fruit.

34)a) Tommy should use the plastic bag.

b) It is waterproof so the plastic bag would not be torn.

c) It is strong.

35)a) F

F

T

F

**35)b)i)The number of hamsters in tank B increase.
ii)The hamster reproduce.**

**36)a)Tank B.
b)There was moisture and warmth in dark place.**

**37)a)Material W.
b)It can hold the most number of bricks without broking it.
c)Fexibility.**

**38)a)Rod R was the magnet.
b)It is the only rod with an end that repelled by the North pole.
c)Iron.**

39)3716542

**40)a)The water level in the beaker would fall.
b)The roots of the balsam plant absorbs the water.**