



**SERANGOON JUNIOR COLLEGE**

**2018 JC2 PRELIMINARY EXAMINATION**

**MATHEMATICS**

**Higher 2**

**9758/1**

**11 Sept 2018**

**3 hours**

Additional materials: Writing paper

List of Formulae (MF 26)

**TIME** : 3 hours

**READ THESE INSTRUCTIONS FIRST**

Write your name and class on the cover page and on all the work you hand in.

Write in blue or black pen on both sides of the paper.

You may use a soft pencil for any diagrams or graphs.

Do not use staples, paper clips, highlighters, glue or correction fluid.

Answer **all** the questions.

Give non-exact numerical answers correct to 3 significant figures, or 1 decimal place in the case of angles in degrees, unless a different level of accuracy is specified in the question.

You are expected to use a graphic calculator.

Unsupported answers from a graphic calculator are allowed unless a question specifically states otherwise.

Where unsupported answers from a graphic calculator are not allowed in a question, you are required to present the mathematical steps using mathematical notations and not calculator commands.

You are reminded of the need for clear presentation in your answers.

The number of marks is given in brackets [ ] at the end of each question or part question.

At the end of the examination, fasten all your work securely together.

Total marks for this paper is 100 marks.

---

**This question paper consists of 6 printed pages (inclusive of this page) and 2 blank pages.**

**[TURN OVER]**

Answer all questions [100 marks].

1 Find  $\int \frac{x^2}{x^2+2x+5} dx$ . [3]

2 The complex numbers  $z$  and  $w$  satisfy the equations

$$zw^*+2z=15i \quad \text{and} \quad 2w+3z=11.$$

Find the complex numbers  $z$  and  $w$ . [6]

3 Without the use of a graphing calculator, find the range of values of  $x$  for which

$$\frac{18}{2-x} \geq x^2 + 4x + 9. \quad [3]$$

Hence find the exact range of values of  $x$  for which  $\frac{18}{2-e^x} \geq e^{2x} + 4e^x + 9$ . [3]

4 (i) The curve with equation  $\frac{y^2}{9} - x^2 = 1$  undergoes a two-step transformations to

become curve  $C$  with equation  $\frac{y^2}{9} - \frac{(x-1)^2}{4} = 1$ .

State the two transformations involved for the curve  $\frac{y^2}{9} - x^2 = 1$ . [2]

(ii) Draw a sketch of the curve  $C$ , labelling clearly the equation(s) of its asymptote(s), intersection with the axes and the coordinates of any turning points. [3]

(iii) Show that the point  $(-1, -3)$  lies on the line  $y = mx + m - 3$  for all real values of  $m$ . [1]

(iv) Hence using the diagram drawn in (ii), find the range of values of  $k$  such that

the equation  $\frac{(kx+k-3)^2}{9} - \frac{(x-1)^2}{4} = 1$  has 2 negative real roots. [2]

5 (i) Find  $\int \ln(x+1) dx$  for  $x > -1$ . Show your working clearly. [2]

(ii) The curve  $C$  is defined by the parametric equations

$$x = 2t - 2\ln(t+1) + 2, \quad y = -2t - 2\ln(t+1) + 1 \quad \text{where } t > -1.$$

Another curve  $L$  is defined by the equation  $x = 2(y+1)^2 - 6$ . The graphs of  $C$  and  $L$  intersect at the point  $A(2,1)$  as shown in the diagram below.

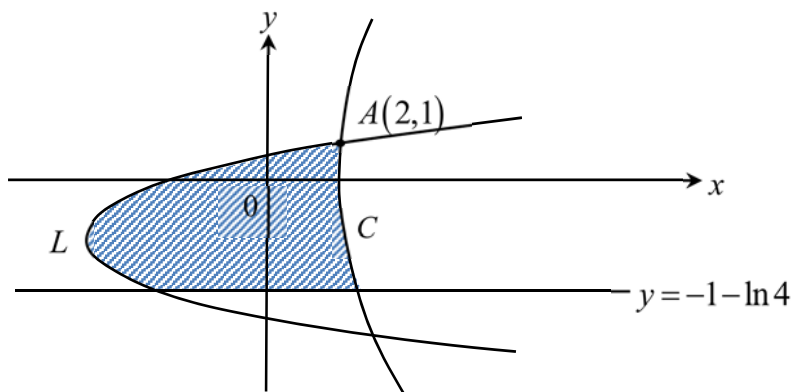

Find the area of the shaded region bounded by  $C$ ,  $L$  and the line

$$y = -1 - \ln 4, \text{ express your answer in the form } \frac{62}{3} + 4A - 2A^2 - \frac{16A^3}{3},$$

where  $A$  is an exact real constant. [6]

6 (a) (i) The twelfth, eighth and fifth terms of an arithmetic progression are three consecutive terms of a converging geometric progression of positive terms with common ratio  $r$ . Find the value of  $r$ . [3]

(ii) For this part, take the value of  $r$  to be  $\frac{3}{4}$ . If the difference between the sum of the first  $n$  terms of the geometric progression and its sum to infinity is less than 0.3% of the sum to infinity, find the least value of  $n$ . [3]

(b) A convergent geometric sequence of positive terms,  $G$  has a non-zero first term  $a$  and common ratio  $r$ .

(i) The sum of the first  $n$  odd-numbered terms of  $G$  is equal to the sum of all terms after the  $(2n-1)$ th term of  $G$ . Show that  $2r^{2n} + r^{2n-1} - 1 = 0$ . [2]

(ii) In another sequence  $H$ , each term is the reciprocal of the corresponding term of  $G$ . If the  $n$ th term of  $G$  and  $H$  is denoted by  $u_n$  and  $v_n$

respectively, show that a new sequence whose  $n$ th term is  $\ln\left(\frac{u_n}{v_n}\right)$ , is

an arithmetic progression. [2]

[TURN OVER]

- 7 (a) The function  $f$  is defined by

$$f : x \mapsto x^2 - 2x - 8, \quad x \in \mathbb{R}, x > k.$$

- (i) State the least value of  $k$  such that  $f^{-1}$  exists and find  $f^{-1}$  in a similar form. [3]

- (ii) Using the value of  $k$  found in (i), state the set of values of  $x$  such that

$$f^{-1}f(x) = ff^{-1}(x). \quad [1]$$

- (b) The functions  $g$  and  $h$  are defined by

$$g : x \mapsto \sqrt{x+41} + a, \quad x \geq -41, a \in \mathbb{R},$$

$$h : x \mapsto x^2 + 10x - 16, \quad x \in \mathbb{R}, x < -7.$$

- (i) Find the exact value of  $x$  for which  $h^{-1}(x) = h(x)$ . [3]

- (ii) Explain clearly why the composite function  $gh$  exists. [1]

- (iii) Find  $gh$  in the form  $bx + c$ , where  $b$  is a real constant and  $c$  is in terms of  $a$ . Explain your answers clearly. [2]

- (iv) State the exact range of  $gh$  in terms of  $a$ . [1]

- 8 A sequence  $u_0, u_1, u_2, \dots$  is such that  $u_r = \frac{1}{r!}$  and  $u_r = u_{r-2} + \frac{r+1-r^2}{r!}$ , when  $n \geq 2$ .

- (i) Show that  $\sum_{r=2}^n \frac{r^2 - r - 1}{r!} = 2 - \frac{n+1}{n!}$ . [3]

- (ii) Hence find  $\sum_{r=8}^{n+5} \frac{r^2 - 3r + 1}{(r-1)!}$  in terms of  $n$ . [3]

Limit Comparison test states that for two series of the form  $\sum_{r=k}^n a_r$  and  $\sum_{r=k}^n b_r$  with

$a_n, b_n \geq 0$  for all  $n$ , if  $\lim_{n \rightarrow \infty} \frac{a_n}{b_n} > 0$ , then both  $\sum_{r=k}^{\infty} a_r$  and  $\sum_{r=k}^{\infty} b_r$  converges or both

diverges.

- (iii) Given that  $\sum_{r=2}^{\infty} \frac{r^2 - r - 1}{r!}$  is convergent, using the test, explain why

$$\sum_{r=2}^{\infty} \frac{r-2}{(r-1)!} \text{ is convergent.} \quad [2]$$

- (iv) Show that  $e - 2 < \frac{1}{2!} + \frac{2}{3!} + \frac{3}{4!} + \frac{4}{5!} + \dots < 2$ . [3]

- 9 The position vectors of points  $A, B, C$  with respect to the origin  $O$  are given by  $\mathbf{a}, \mathbf{b}$  and  $\mathbf{c}$  respectively. The non-zero vectors  $\mathbf{a}, \mathbf{b}$  and  $\mathbf{c}$  satisfy the equation  $\mathbf{a} + \mathbf{b} + \mathbf{c} = \mathbf{0}$ .

- (i) By considering the plane  $OAB$  or otherwise, explain clearly why  $O, A, B$  and  $C$  lies on the same plane.

Show that  $\mathbf{a} \times \mathbf{b} = \mathbf{b} \times \mathbf{c} = \mathbf{c} \times \mathbf{a}$ . [4]

- (ii) Show that the area of triangle  $ABC$  is given by  $k|\mathbf{a} \times \mathbf{b}|$  where  $k$  is a constant to be determined. [3]

- (iii) If  $\mathbf{b}$  is a unit vector and  $\mathbf{a}$  is perpendicular to  $\mathbf{b}$ , find the length of projection of  $\vec{AC}$  onto  $\vec{OB}$ . Given that the magnitude of  $\vec{AC}$  is 2 units, deduce the angle between  $\vec{AC}$  and  $\vec{OA}$ . [5]

- 10 The diagram below shows a rectangular container of variable height  $h$  cm, inscribed in a right circular cone with fixed height  $b$  cm and a radius of 20 cm. The four corners of the rectangular container's upper surface  $ABCD$  is always in contact with the conical surface. The point  $O$  is at the centre of the rectangle  $ABCD$ . The rectangular container is made with material of negligible thickness.

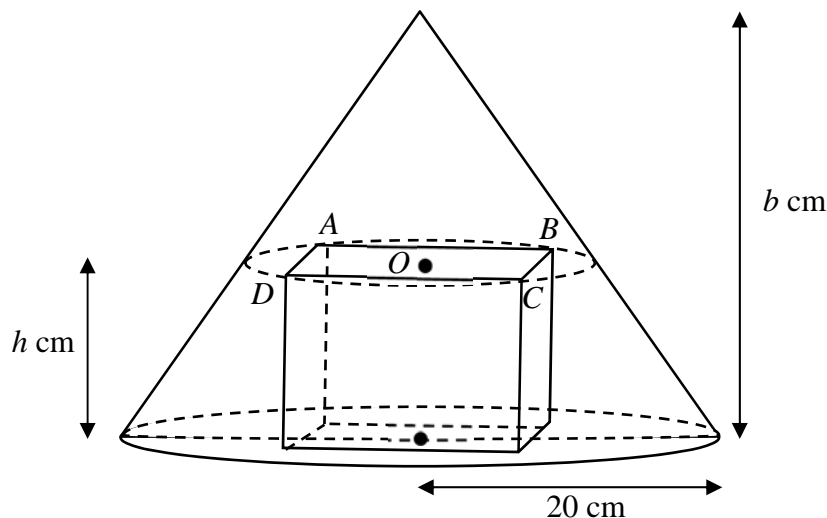

- (i) If the fixed angle  $BOC$  is  $\theta$ , show that the storage volume of the rectangular container in the shape of a cuboid is given by  $V = 800b^{-2}(b-h)^2 h \sin \theta$ . [3]
- (ii) Find the value of  $h$  such that the rectangular container has a maximum storage volume, leaving your answer in terms of  $b$ . [5]

[TURN OVER]

The rectangular container is opened at its upper surface  $ABCD$  and completely filled with a type of liquid perfume. A fragrance chemist placed the container in a room and allowed the liquid perfume to evaporate. It is known that the heat energy of the liquid perfume in the container,  $E$  joules, is related to the height of the container by the equation

$$E = h - 3h^{-\frac{1}{2}}.$$

- (iii) Given that the perfume evaporates at a rate of  $0.08 \text{ cm}^3$  every hour and that the value of  $\theta$  is  $\frac{\pi}{6}$ , calculate the rate of change of heat energy of the perfume when the height of the rectangular container is  $\frac{b}{5}$  cm, leaving your answer in the form  $p + q\left(\frac{5}{b}\right)^{\frac{3}{2}}$ , where  $p$  and  $q$  are exact constants to be determined. [4]

- 11 A charged particle is placed in a varying magnetic field. A researcher decides to fit a mathematical model for the path of the fast-moving charged particle under the influence of the magnetic field. The particle was observed for the first 1.5 seconds. The displacement of the particle measured with respect to the origin in the horizontal and vertical directions, at time  $t$  seconds, is denoted by the variables  $x$  and  $y$  respectively. It is given that when  $t = 0$ ,  $x = -\frac{1}{32}$ ,  $y = 0$  and  $\frac{dx}{dt} = 3$ . The variables are related by the differential equations

$$(\cos t) \frac{dy}{dt} + y \sin t = 4 \cos^2 t - y^2 \quad \text{and} \quad \frac{d^2x}{dt^2} = \cos 3t \cos t.$$

- (i) Using the substitution  $y = v \cos t$ , show that  $\frac{dv}{dt} = 4 - v^2$  and hence find  $y$  in terms of  $t$ . [7]
- (ii) Show that  $x = -\frac{1}{32} \cos 4t - \frac{1}{8} \cos 2t + 3t + \frac{1}{8}$ . [4]
- (iii) Sketch the path travelled by the particle for the first 1.5 seconds, labelling the coordinates of the end points of the path. The evaluation of the  $y$ -intercept is not needed. [2]

**THE END**



**SERANGOON JUNIOR COLLEGE**  
**2018 JC2 PRELIMINARY EXAMINATION**  
**MATHEMATICS**

**Higher 2**

**9758/2**

**17 Sept 2018**

**3 hours**

Additional materials: Writing paper

List of Formulae (MF 26)

**TIME** : 3 hours

**READ THESE INSTRUCTIONS FIRST**

Write your name and class on the cover page and on all the work you hand in.

Write in blue or black pen on both sides of the paper.

You may use a soft pencil for any diagrams or graphs.

Do not use staples, paper clips, highlighters, glue or correction fluid.

Answer **all** the questions.

Give non-exact numerical answers correct to 3 significant figures, or 1 decimal place in the case of angles in degrees, unless a different level of accuracy is specified in the question.

You are expected to use a graphic calculator.

Unsupported answers from a graphic calculator are allowed unless a question specifically states otherwise.

Where unsupported answers from a graphic calculator are not allowed in a question, you are required to present the mathematical steps using mathematical notations and not calculator commands.

You are reminded of the need for clear presentation in your answers.

The number of marks is given in brackets [ ] at the end of each question or part question.

At the end of the examination, fasten all your work securely together.

Total marks for this paper is 100 marks

---

**This question paper consists of 7 printed pages (inclusive of this page) and 1 blank page.**

**[TURN OVER]**

## Section A: Pure Mathematics [40 marks].

- 1  $R$  is the region enclosed by the line  $y = -5$  and the curves  $y = -x^2 + 2x - 5$  and  $\frac{x^2}{4} + \frac{(y+5)^2}{16} = 1$  as shown in the diagram below.

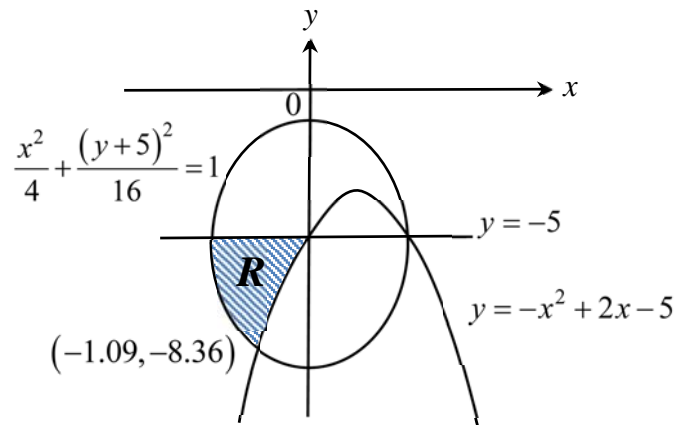

Find the volume generated by region  $R$  when it is rotated  $2\pi$  radians about the  $x$ -axis. Leave your answer correct to 2 decimal places. [3]

- 2 A curve has parametric equations

$$x = \tan \theta, \quad y = 2 \sec \theta \quad \text{for } 0 \leq \theta < 2\pi.$$

The equation of the tangent to the curve at the point  $P$  with parameter  $p$  is given by  $y = (2 \sin p)x + 2 \cos p$ .

- (i) The tangent at  $P$  meets the  $x$  and  $y$  axes at the points  $A$  and  $B$  respectively. Find the Cartesian equation of the locus of the mid-point of  $AB$  as  $p$  varies. [3]
- (ii) The tangent at  $P$  meets the line  $y = 2x$  at the point  $S$  and the line  $y = -2x$  at the point  $T$ . Show that the area of the triangle  $OST$  is independent of  $p$ , where  $O$  is the origin. [4]

- 3 Given that  $\ln y = e^{\tan^{-1}x}$ , show that  $(1+x^2) \frac{d^2y}{dx^2} = (\ln y + 1 - 2x) \frac{dy}{dx}$ . [2]

- (i) Find the Maclaurin's series for  $y$  up to and including the term in  $x^3$ . [4]
- (ii) Deduce the Maclaurin's series for  $y$ , where  $\ln y = e^{\tan^{-1}x} + x - 1$ , up to and including the term in  $x^3$ . [3]



- 4 Given that the equation  $f(z) = 2z^3 + az^2 + (2a-4)z + (2a-8) = 0$  has no real solution, explain clearly why  $a$  is not a real number. [2]

(i) It is known that  $f$  has a factor  $(2z + i)$ , find  $a$ . Hence find all the roots of  $f(z) = 0$ , showing your workings clearly. [4]

(ii) Deduce the roots of the equation  $2 - \frac{a}{w} + \frac{(2a-4)}{w^2} - \frac{2a-8}{w^3} = 0$ , where  $a$  takes the value obtained in (i). [2]

- 5 A hollow metallic ramp, in the shape of a prism, is constructed for the marching contingent to march onto to reach an elevated platform from the ground during the national day parade.

The diagram below shows the prism with  $O$  as the origin of position vectors and the unit vectors  $\mathbf{i}$ ,  $\mathbf{j}$  and  $\mathbf{k}$  are parallel to  $OA$ ,  $OC$  and  $OE$  respectively.

It is given that  $OE = CD = 1$  m,  $OA = CB = 2$  m and  $OC = AB = ED = 4$  m.

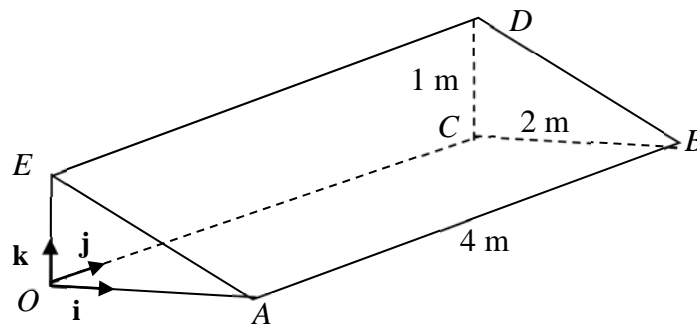

A laser beam in the form of a line  $l$  has Cartesian equation  $\frac{a+x}{2} = z$ ,  $y=1$ , where

$a \in \mathbb{R}$ , is emitted onto the plane  $ABDE$ .

(i) Find, in terms of  $a$ , the coordinates of the point of intersection,  $M$ , of the laser beam and the plane  $ABDE$ . [4]

For the following parts of the question assume  $a = 0$ .

(ii) The laser beam is reflected about the plane  $ABDE$ . By finding the foot of perpendicular from  $Q(0,1,0)$  to the plane  $ABDE$ , find the equation of the reflected beam. [5]

(iii) The path traced out by an ant crawling on the floor  $OABC$  is given by

$$\mathbf{r} = \begin{pmatrix} 2 \\ 0 \\ 0 \end{pmatrix} + \beta \begin{pmatrix} -1 \\ 2 \\ 0 \end{pmatrix}, \beta \in \mathbb{R}. \text{ Let } P \text{ be the point on the path, located under the}$$

ramp, whereby the ant is equidistant between the planes  $ABDE$  and  $OCDE$ .

Find the position vector of point  $P$  exactly. [4]

**Section B: Statistics [60 marks]**

- 6 A jackfruit farm produces 2 types of jackfruit pulps namely Grade A and Grade B. The pulps are randomly packed into boxes of 8. The probability that a box contains at most 3 Grade A jackfruit pulps is 0.00245. A fruit trading wholesaler places a monthly order of 1000 boxes of jackfruit pulps for 5 years. Find the approximate probability that the mean number of boxes that contain at most 3 Grade A jackfruit pulps in a month is more than 3. [You may assume that there are 12 months in a year.] [4]
- 7 A player throws an unbiased six-sided die and the number shown on the top face is noted. If it is not a six, the score is the number shown on the top face. If it is a six, he throws the die a second time and the score is the total score obtained from his two throws. The player has at most two throws.
- (i) Construct the probability distribution table on the score for the player. [2]
- Given that the expected player's score is  $\frac{49}{12}$ ,
- (ii) find the exact value of the variance of the player's score, showing your workings clearly. [3]
- 8 The length of time that Somesong phones last in between charges has a normal distribution with mean 20 hours and standard deviation 2 hours. The length of time that Apfel phones last in between charges has a normal distribution with mean  $\mu$  hours and standard deviation  $\sigma$  hours.
- (a) The average length of time two randomly chosen Somesong phones and one randomly chosen Apfel phone will last in between charges is equally likely to be less than 19 hours or more than 23 hours, with the probability known to be 0.02275.
- (i) Calculate the values of  $\mu$  and  $\sigma$ . [3]
- (ii) Find the probability that twice the length of time a Somesong phone lasts in between charges differs from 40 hours by at least 2 hours. [2]
- (b) Six randomly chosen Somesong phones are examined. Find the probability that the sixth Somesong phone is the fourth Somesong phone that lasts more than 22 hours in between charges. [2]

- 9** A customer wishes to investigate the shelf life of the durian puffs produced by a baker before they turn bad when placed at room temperature and pressure. It is assumed that the shelf life of the durian puffs are independent of one another. Based on past records, the baker claims that the mean shelf life of the durian puffs is at least 8 hours. To test this claim, the customer recorded the shelf life of 55 randomly chosen durian puffs and found that its mean is 7.4 hours and standard deviation is 2.6 hours.
- (i) Carry out a test, to determine whether there is any evidence to doubt the baker's claim at 5% significance level. [5]
- (ii) Explain, in the context of the question, the meaning of 'at 5% significance level'. [1]
- (iii) Suppose the population standard deviation is 3.2 hours now and the baker claims that the mean shelf life the durian puffs is 8 hours. A new sample of 10 durian puffs is taken. Using this sample, the customer conducts another test and found that the baker's claim is not rejected at the 5% significance level. Stating a necessary assumption for the test, find the set of values that the sample mean shelf life,  $\bar{y}$ , can take. [4]
- 10** (a) A group of twelve people consists of one pair of sisters, one set of three brothers, a family of three and 4 others.
- (i) The twelve people are grouped into three groups of 4. Find the number of ways where the family of three are together. [2]
- (ii) The twelve people are arranged randomly in a line. Find the number of ways that the sisters are not together and the brothers are all separated. [3]
- (b) For events  $A$  and  $B$ , it is given that  $P(A) = \frac{11}{20}$ ,  $P(B) = \frac{2}{5}$  and  $P(A \cap B) = \frac{1}{4}$ .
- (i) Find the probability where event  $A$  occurs or event  $B$  occurs but not both. [1]
- (ii) Find the probability where event  $B$  has occurred but not  $A$ . [1]
- For a third event  $C$ , it is given that  $P(C) = \frac{1}{2}$  and that  $A$  and  $C$  are independent,
- (iii) Find the range of values of  $P(A' \cap B' \cap C)$ . [3]

- 11** In an attempt to reduce the operating costs of an airline company, an analyst collected data on the seat capacity and the total fuel use of the different types of airplanes used for a particular route, as shown in the table below.

Seat capacity, $x$ (in hundreds)	4.07	3.84	4	3.31	2.48	2.92	3.1	3.57
Total fuel use, $y$ ( $10^3$ tonnes)	140	115	$m$	11	20	25	33	74

- (a) (i)** Given that the equation of the least squares regression line of  $y$  on  $x$  is  

$$y = 79.695x - 205.86,$$

show that the value of  $m$  is 110, correct to the nearest whole number. [2]

- (ii)** Give an interpretation, in context, of the gradient of the least squares regression line given in **(a)(i)**. [1]

The analyst suspects that the fuel use for one of the points has been recorded wrongly.

- (b) (i)** Draw a scatter diagram for the data, labelling the axes clearly. On your diagram, circle the point for which the total fuel use has been recorded wrongly and label it as  $Q$ . [2]
- (ii)** Explain from your scatter diagram why the relationship between  $x$  and  $y$  should not be modelled by an equation of the form  $y = ax + b$ . [1]

For the following parts of this question, you should exclude the point  $Q$  for the subsequent calculation.

- (iii)** The analyst is presented with the following two models:

$$(A) y = ae^x + b$$

$$(B) y = ax^3 + b.$$

Explain clearly which of the two models is the more appropriate model. [2]

- (iv)** Using the more appropriate model from **(b)(iii)**, estimate the total fuel use when the seating capacity of an airplane is 331. Leave your answer to the nearest whole number. [2]
- (v)** Give two reasons why the estimation in part **(b)(iv)** is reliable. [2]

**12** Based on past statistical data of high speed train journey, there is a 8% chance that a passenger with reservation made will not show up. In order to maximise revenue, a high speed train company accepts more reservations than the passenger capacity of its trains.

- (i) State 2 assumptions needed such that the number of passengers who do not show up for a high speed train journey may be well modelled by a Binomial distribution. [2]

A train company operates a high speed train from Burong Lake to Huahin Cove which has a capacity of 280 passengers.

- (ii) Find the probability that when 300 reservations are accepted, the high speed train journey is overbooked, i.e. there is not enough seats available for the passengers who show up. [2]

- (iii) Find the maximum number of reservations that should be accepted in order to ensure that the probability of overbooking is less than 1%. [3]

The high speed train operates once daily throughout the year and 300 reservations are accepted for each journey.

- (iv) Find the probability that no high speed train journey is overbooked in a week. [2]

- (v) Two such journeys from Burong Lake to Huahin Cove with 300 reservations each are examined. If the total number of passengers who turned up for these two journeys is at most 550 passengers, find the probability that one of the journeys is overbooked by at most 2 passengers. [3]

**THE END**

**[TURN OVER]**



**SERANGOON JUNIOR COLLEGE**

**2018 JC2 PRELIMINARY EXAMINATION**

**MATHEMATICS**

**Higher 2**

**9758/1**

**11 Sept 2018**

**3 hours**

Additional materials: Writing paper

List of Formulae (MF 26)

**TIME** : 3 hours

**READ THESE INSTRUCTIONS FIRST**

Write your name and class on the cover page and on all the work you hand in.

Write in blue or black pen on both sides of the paper.

You may use a soft pencil for any diagrams or graphs.

Do not use staples, paper clips, highlighters, glue or correction fluid.

Answer **all** the questions.

Give non-exact numerical answers correct to 3 significant figures, or 1 decimal place in the case of angles in degrees, unless a different level of accuracy is specified in the question.

You are expected to use a graphic calculator.

Unsupported answers from a graphic calculator are allowed unless a question specifically states otherwise.

Where unsupported answers from a graphic calculator are not allowed in a question, you are required to present the mathematical steps using mathematical notations and not calculator commands.

You are reminded of the need for clear presentation in your answers.

The number of marks is given in brackets [ ] at the end of each question or part question.

At the end of the examination, fasten all your work securely together.

Total marks for this paper is 100 marks.

---

**This question paper consists of 6 printed pages (inclusive of this page) and 2 blank pages.**

**[TURN OVER]**

Answer all questions [100 marks].

<b>1</b>	Find $\int \frac{x^2}{x^2+2x+5} dx$ .	[3]
	<b>Solution</b>	
	$\int \frac{x^2}{x^2+2x+5} dx = \int 1 - \frac{2x+5}{x^2+2x+5} dx$	
	$= \int 1 dx - \int \frac{2x+2}{x^2+2x+5} dx - 3 \int \frac{1}{(x+1)^2+4} dx$	
	$= x - \ln(x^2+2x+5) - \frac{3}{2} \tan^{-1}\left(\frac{x+1}{2}\right) + c$	
<b>2</b>	The complex numbers $z$ and $w$ satisfy the equations $zw^*+2z=15i$ and $2w+3z=11$ .	
	Find the complex numbers $z$ and $w$ .	[6]
	<b>Solution</b>	
	$zw^*+2z=15i$ L L (1)	
	$w = \frac{1}{2}(11-3z)$ L L (2)	
	Subst (2) into (1) gives	
	$\frac{1}{2}z(11-3z^*)+2z=15i$	
	$\frac{11}{2}z - \frac{3}{2} z ^2 + 2z = 15i$	
	$\frac{15}{2}z - \frac{3}{2} z ^2 = 15i$	
	Let $z = x + iy$	
	$\frac{15}{2}(x+iy) = \frac{3}{2}(x^2+y^2) + 15i$	
	Comparing the real and Imaginary parts, we have	
	$\frac{15}{2}y = 15$ and $\frac{15}{2}x = \frac{3}{2}x^2 + \frac{3}{2}y^2$ L L (3)	
	$y = 2$	
	Subst into (3) gives	
	$x^2 - 5x + 4 = 0$	
	$(x-4)(x-1) = 0$	
	$\therefore x = 1$ or $4$	
	When $z = 1 + 2i$ , $w = \frac{1}{2}(11 - 3 - 6i) = 4 - 3i$	
	When $z = 4 + 2i$ , $w = \frac{1}{2}(11 - 12 - 6i) = -\frac{1}{2} - 3i$	

3	Without the use of a graphing calculator, find the range of values of $x$ for which $\frac{18}{2-x} \geq x^2 + 4x + 9$ .	[3]
	Hence find the exact range of values of $x$ for which $\frac{18}{2-e^x} \geq e^{2x} + 4e^x + 9$ .	[3]
	<b>Solution</b>	
	$\frac{18}{2-x} \geq x^2 + 4x + 9$	
	$\frac{18 + (x-2)(x^2 + 4x + 9)}{2-x} \geq 0$	
	$\frac{18 + x^3 + 2x^2 + x - 18}{2-x} \geq 0$	
	$\frac{x(x+1)^2}{2-x} \geq 0$	
	$x = -1$ or $0 \leq x < 2$	
	Replace $x$ by $e^x$	
	So $e^x = -1$ or $0 \leq e^x < 2$	
	No solution or $(0 \leq e^x \text{ and } e^x < 2)$	
	No solution or $(x \in \emptyset \text{ and } x < \ln 2)$	
	$\therefore x < \ln 2$	
4	<p>(i) The curve with equation <math>\frac{y^2}{9} - x^2 = 1</math> undergoes a two-step transformations to become curve <math>C</math> with equation <math>\frac{y^2}{9} - \frac{(x-1)^2}{4} = 1</math>.</p> <p>State the two transformations involved for the curve <math>\frac{y^2}{9} - x^2 = 1</math>.</p> <p>(ii) Draw a sketch of the curve <math>C</math>, labelling clearly the equation(s) of its asymptote(s), intersection with the axes and the coordinates of any turning points.</p> <p>(iii) Show that the point <math>(-1, -3)</math> lies on the line <math>y = mx + m - 3</math> for all real values of <math>m</math>.</p> <p>(iv) Hence using the diagram drawn in (ii), find the range of values of <math>k</math> such that the equation <math>\frac{(kx+k-3)^2}{9} - \frac{(x-1)^2}{4} = 1</math> has 2 negative real roots.</p>	[2] [3] [1] [2]
	<b>Solution</b>	
	<b>(i) Method 1</b>	

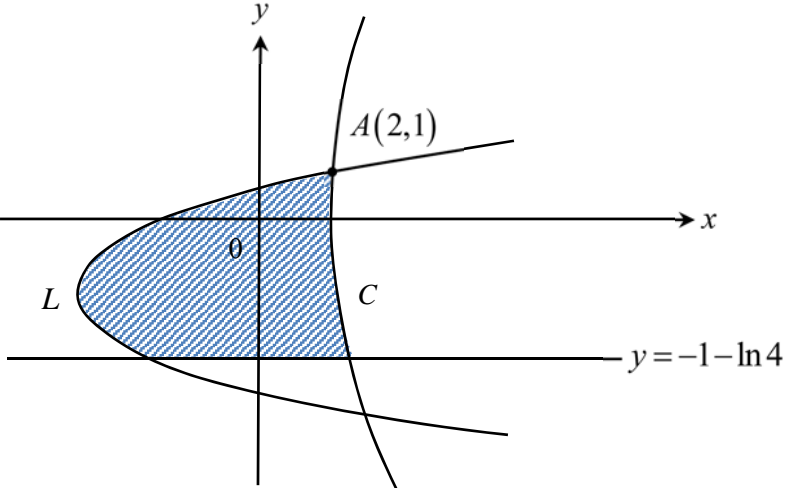

	$\frac{y^2}{9} - x^2 = 1 \rightarrow \frac{y^2}{9} - \frac{x^2}{4} = 1 \rightarrow \frac{y^2}{9} - \frac{(x-1)^2}{4} = 1$	
	(1) Scaling parallel to the $x$ axis by a scale factor of 2.	
	(2) Translation of 1 unit in the positive $x$ direction.	
	<b>Method 2</b>	
	$\frac{y^2}{9} - x^2 = 1 \rightarrow \frac{y^2}{9} - \left(x - \frac{1}{2}\right)^2 = 1 \rightarrow \frac{y^2}{9} - \frac{(x-1)^2}{4} = 1$	
	(1) Translation of 0.5 units in the positive $x$ direction	
	(2) Scaling parallel to the $x$ axis by a scale factor of 2.	
	(iii) When $x = -1$ , $\text{RHS} = m(-1) + m - 3 = -3 = \text{LHS}$	
	Hence $(-1, -3)$ lies on the line $y = mx + m - 3$ for all $m$ .	
	(iv) From the sketch, the range of values of $k$ are $k > \frac{3\sqrt{5}}{2} + 3$ or $k < -\frac{3}{2}$	

5	(i) Find $\int \ln(x+1) dx$ for $x > -1$ . Show your working clearly.	[2]
	(ii) The curve $C$ is defined by the parametric equations $x = 2t - 2\ln(t+1) + 2$ , $y = -2t - 2\ln(t+1) + 1$ where $t > -1$ .	
	Another curve $L$ is defined by the equation $x = 2(y+1)^2 - 6$ . The graphs of $C$ and $L$ intersect at the point $A(2,1)$ as shown in the diagram below.	
		
	Find the area of the shaded region bounded by $C$ , $L$ and the line $y = -1 - \ln 4$ , express your answer in the form $\frac{62}{3} + 4A - 2A^2 - \frac{16A^3}{3}$ , where $A$ is an exact real constant.	[6]
	<b>Solution</b>	
	(i) $\int \ln(1+x) dx = x \ln(1+x) - \int \frac{x}{1+x} dx$	
	$= x \ln(1+x) - \int 1 - \frac{1}{1+x} dx$ $= x \ln(1+x) - x + \ln(1+x) + c$ $= (x+1) \ln(1+x) - x + c$	
	(ii) Area = $\int_{-1-\ln 4}^1 x_C dy - \int_{-1-\ln 4}^1 [2(y+1)^2 - 6] dy$	
	$= \int_1^0 [2t+2-2\ln(1+t)] \left(-2-\frac{2}{1+t}\right) dt - \left[ \frac{2(y+1)^3}{3} - 6y \right]_{-1-\ln 4}^1$	
	$= 4 \int_0^1 [t+1-\ln(1+t)] \left(1+\frac{1}{1+t}\right) dt - \left\{ \frac{16}{3} - 6 - \left[ \frac{-2(\ln 4)^3}{3} + 6 + 6 \ln 4 \right] \right\}$	
	$= 4 \int_0^1 t+2 dt - 4 \int_0^1 \ln(1+t) dt - 4 \int_0^1 \frac{\ln(1+t)}{1+t} dt - \left[ -\frac{20}{3} + \frac{2(\ln 4)^3}{3} - 6 \ln 4 \right]$	

	$= \left[ 2(t+2)^2 \right]_0^1 - 4 \left[ (1+t) \ln(1+t) - t \right]_0^1 - 2 \left[ (\ln(1+t))^2 \right]_0^1 - \left[ -\frac{20}{3} + \frac{2(\ln 4)^3}{3} - 6 \ln 4 \right]$	
	$= (18-8) - 4[2 \ln 2 - 1] - 2(\ln 2)^2 + \frac{20}{3} - \frac{2(\ln 4)^3}{3} + 6 \ln 4$	
	$= 14 - 8 \ln 2 - 2(\ln 2)^2 + \frac{20}{3} - \frac{2(\ln 4)^3}{3} + 6 \ln 4$	
	$= \frac{62}{3} + 4 \ln 2 - 2(\ln 2)^2 - \frac{16(\ln 2)^3}{3}$	
<b>6</b>	<b>(a) (i)</b> The twelfth, eighth and fifth terms of an arithmetic progression are three consecutive terms of a converging geometric progression of positive terms with common ratio $r$ . Find the value of $r$ .	[3]
	<b>(ii)</b> Take the value of $r$ to be $\frac{3}{4}$ . If the difference between the sum of the first $n$ terms of the geometric progression and its sum to infinity is less than 0.3% of the sum to infinity, find the least value of $n$ .	[3]
	<b>(b)</b> A convergent geometric sequence of positive terms, $G$ has first non-zero term $a$ and common ratio $r$ .	
	<b>(i)</b> The sum of the first $n$ odd-numbered terms of $G$ is equal to the sum of all terms after the $(2n-1)$ th term of $G$ . Show that $2r^{2n} + r^{2n-1} - 1 = 0$ .	[2]
	<b>(ii)</b> In another sequence $H$ , each term is the reciprocal of the corresponding term of $G$ . If the $n$ th term of $G$ and $H$ is denoted by $u_n$ and $v_n$ respectively, show that a new sequence whose $n$ th term is $\ln \left( \frac{u_n}{v_n} \right)$ , is an arithmetic progression.	[2]
	<b>Solution</b>	
	<b>(ai)</b> Let $b$ and $d$ be the first term and common difference of the arithmetic progression.	
	$ar^{n-1} = b + 11d$ L L (1)	
	$ar^n = b + 7d$ L L (2)	
	$ar^{n+1} = b + 4d$ L L (3)	
	Equation (1)–(2) gives	
	$ar^{n-1} - ar^n = 4d$	
	Equation (2)–(3) gives	
	$ar^n - ar^{n+1} = 3d$	
	Hence $4(ar^n - ar^{n+1}) = 3(ar^{n-1} - ar^n)$	
	$4ar^{n+1} - 7ar^n + 3ar^{n-1} = 0$	

	$ar^{n-1}(4r^2 - 7r + 3) = 0$	
	$(4r - 3)(r - 1) = 0$ Since $a$ and $r$ are non-zero	
	$r = \frac{3}{4}$ Since it is a converging GP.	
	(ii) $\left  \frac{a(1-r^n)}{1-r} - \frac{a}{1-r} \right  < 0.003 \left( \frac{a}{1-r} \right)$ or $\frac{a}{1-r} - \frac{a(1-r^n)}{1-r} < 0.003 \left( \frac{a}{1-r} \right)$ Since $S_\infty > S_n$ as $a$ and $r$ are positive.	
	$\left( \frac{3}{4} \right)^n < 0.003$	
	$n > \frac{\ln(0.003)}{\ln\left(\frac{3}{4}\right)}$	
	$n > 20.19$	
	Hence least $n$ is 21.	
	(bi) $a + ar^2 + ar^4 + \dots + a(r^2)^{n-1} = ar^{2n-1} + ar^{2n} + \dots$	
	$\frac{a(1-r^{2n})}{1-r^2} = \frac{ar^{2n-1}}{1-r}$ for sum of GP	
	Since $a \neq 0$ , $r \neq 1$ $\frac{1-r^{2n}}{(1-r)(1+r)} = \frac{r^{2n-1}}{1-r}$	
	$1-r^{2n} = (1+r)r^{2n-1}$ $1-r^{2n} = r^{2n-1} + r^{2n}$ $2r^{2n} + r^{2n-1} - 1 = 0$ (shown)	
	(ii) $\ln\left(\frac{u_n}{v_n}\right) - \ln\left(\frac{u_{n-1}}{v_{n-1}}\right)$	
	$= \ln u_n - \ln v_n - \ln u_{n-1} + \ln v_{n-1}$ $= \ln\left(\frac{u_n}{u_{n-1}}\right) + \ln\left(\frac{v_{n-1}}{v_n}\right)$	
	$= \ln r + \ln\left(\frac{1}{r}\right)^{-1}$ $= 2 \ln r$ (constant) Hence the new sequence is an arithmetic progression.	

[TURN OVER]

7	(a) The function $f$ is defined by	
	$f: x \mapsto x^2 - 2x - 8, \quad x \in \mathbb{R}, x > k.$	
	(i) State the least value of $k$ such that $f^{-1}$ exists and find $f^{-1}$ in a similar form.	[3]
	(ii) Using the value of $k$ found in (i), state the set of values of $x$ such that $f^{-1}f(x) = ff^{-1}(x).$	[1]
	(b) The functions $g$ and $h$ are defined by	
	$g: x \mapsto \sqrt{x+41} + a, \quad x \geq -41, a \in \mathbb{R},$	
	$h: x \mapsto x^2 + 10x - 16, \quad x \in \mathbb{R}, x < -7.$	
	(i) Find the exact value of $x$ for which $h^{-1}(x) = h(x).$	[3]
	(ii) Explain clearly why the composite function $gh$ exists.	[1]
	(iii) Find $gh$ in the form $bx + c$ , where $b$ is a real constant and $c$ is in terms of $a$ . Explain your answers clearly.	[2]
	(iv) State the exact range of $gh$ in terms of $a$ .	[1]
	<b>Solution</b>	
	(a)(i) Least value of $k$ is 1.	
	$y = (x-1)^2 - 9$	
	$x = 1 \pm \sqrt{y+9}$	
	$\therefore x = 1 + \sqrt{y+9} \quad (\text{Q } x > 1)$	
	So $f^{-1}: x \mapsto 1 + \sqrt{x+9}, \quad x \in \mathbb{R}, x > -9.$	
	(ii) $(1, \infty)$	
	(b)(i) $h^{-1}(x) = h(x)$	
	$\Rightarrow h(x) = x$	
	$x^2 + 10x - 16 = x$	
	$x^2 + 9x - 16 = 0$	
	$x = \frac{-9 \pm \sqrt{81 - 4(-16)}}{2}$	
	$x = -\frac{9}{2} + \frac{\sqrt{145}}{2} \text{ (Rejected Q } x < -7) \text{ or } -\frac{9}{2} - \frac{\sqrt{145}}{2}$	
	(ii) $R_h = (-37, \infty)$ and $D_g = [-41, \infty)$	
	Since $R_h \subseteq D_g$ , so $gh$ exists.	
	(iii) $gh(x) = g(x^2 + 10x - 16)$	
	$= \sqrt{x^2 + 10x + 25} + a$	
	$=  x+5  + a$	
	$= -x + a - 5 \quad (\text{Q } x < -7)$	
	(iv) $(a+2, \infty)$	

8	A sequence $u_0, u_1, u_2, \dots$ is such that $u_r = \frac{1}{r!}$ and $u_r = u_{r-2} + \frac{r+1-r^2}{r!}$ , when $n \geq 2$ .	
	(i) Show that $\sum_{r=2}^n \frac{r^2 - r - 1}{r!} = 2 - \frac{n+1}{n!}$ .	[3]
	(ii) Hence find $\sum_{r=8}^{n+5} \frac{r^2 - 3r + 1}{(r-1)!}$ in terms of $n$ .	[3]
	Limit Comparison test states that for two series of the form $\sum_{r=k}^n a_r$ and $\sum_{r=k}^n b_r$ with $a_n, b_n \geq 0$ for all $n$ , if $\lim_{n \rightarrow \infty} \frac{a_n}{b_n} > 0$ , then both $\sum_{r=k}^{\infty} a_r$ and $\sum_{r=k}^{\infty} b_r$ converges or both diverges.	
	(iii) Given that $\sum_{r=2}^{\infty} \frac{r^2 - r - 1}{r!}$ is convergent, using the test, explain why $\sum_{r=2}^{\infty} \frac{r-2}{(r-1)!}$ is convergent.	[2]
	(iv) Show that $e - 2 < \frac{1}{2!} + \frac{2}{3!} + \frac{3}{4!} + \frac{4}{5!} + \dots < 2$ .	[3]
	<b>Solution</b>	
	(i) $\sum_{r=2}^n \frac{r^2 - r - 1}{r!} = \sum_{r=2}^n (u_{r-2} - u_r)$	
	$= \begin{array}{l} u_0 - u_2 \\ +u_1 - u_3 \\ +u_2 - u_4 \\ +u_3 - u_5 \\ +\dots\dots\dots \\ +u_{n-4} - u_{n-2} \\ +u_{n-3} - u_{n-1} \\ +u_{n-2} - u_n \end{array}$	
	$= u_0 + u_1 - u_{n-1} - u_n$ $= 2 - \frac{1}{(n-1)!} - \frac{1}{n!}$ $= 2 - \frac{n+1}{n!}$	
	(ii) $\sum_{r=8}^{n+5} \frac{r^2 - 3r + 1}{(r-1)!} = \sum_{r=7}^{n+4} \frac{r^2 - r - 1}{r!}$ (Replace $r$ by $r+1$ )	

	$= \sum_{r=2}^{n+4} \frac{r^2 - r - 1}{r!} - \sum_{r=2}^6 \frac{r^2 - r - 1}{r!}$ $= 2 - \frac{n+5}{(n+4)!} - \left(2 - \frac{7}{6!}\right)$	
	$= \frac{7}{720} - \frac{n+5}{(n+4)!}$	
	<p>(iii) Consider <math>\lim_{n \rightarrow \infty} \left[ \frac{\left( \frac{n-2}{(n-1)!} \right)}{\left( \frac{n^2 - n - 1}{n!} \right)} \right] = \lim_{n \rightarrow \infty} \left[ \frac{n-2}{(n-1)!} \times \frac{n!}{n^2 - n - 1} \right]</math></p>	
	$= \lim_{n \rightarrow \infty} \frac{n^2 - 2n}{n^2 - n - 1} = \lim_{n \rightarrow \infty} \left( 1 - \frac{n-1}{n^2 - n - 1} \right) = 1$	
	<p>Since <math>\sum_{r=2}^{\infty} \frac{r^2 - r - 1}{r!}</math> is convergent, So <math>\sum_{r=2}^{\infty} \frac{r-2}{(r-1)!}</math> is convergent by the Limit Comparison Test.</p>	
	<p>(iv) Observe that <math>\sum_{r=2}^{\infty} \frac{r-1}{r!} = \frac{1}{2!} + \frac{2}{3!} + \frac{3}{4!} + \frac{4}{5!} + \dots</math> and <math>\frac{r-1}{r!} &lt; \frac{r^2 - r - 1}{r!}</math> for all <math>r \geq 3</math>,</p>	
	$\therefore \sum_{r=3}^n \frac{r-1}{r!} < \sum_{r=3}^n \frac{r^2 - r - 1}{r!}$	
	$\text{but } \frac{1}{2} + \sum_{r=3}^n \frac{r-1}{r!} < \frac{1}{2} + \sum_{r=3}^n \frac{r^2 - r - 1}{r!}$	
	$\Rightarrow \sum_{r=2}^n \frac{r-1}{r!} < \sum_{r=2}^n \frac{r^2 - r - 1}{r!}$	
	<b>Method 1</b>	
	<p>Also, <math>\frac{1}{r!} &lt; \frac{r-1}{r!}</math> for all <math>r &gt; 2</math> So <math>\sum_{r=3}^n \frac{1}{r!} &lt; \sum_{r=3}^n \frac{r-1}{r!}</math> <math>\Rightarrow \frac{1}{2!} + \sum_{r=3}^n \frac{1}{r!} &lt; \frac{1}{2!} + \sum_{r=3}^n \frac{r-1}{r!}</math> <math>\therefore \sum_{r=2}^n \frac{1}{r!} &lt; \sum_{r=2}^n \frac{r-1}{r!}</math></p>	
	$\therefore \sum_{r=0}^n \frac{1}{r!} - \frac{1}{0!} - \frac{1}{1!} < \sum_{r=2}^n \frac{r-1}{r!} < \sum_{r=2}^n \frac{r^2 - r - 1}{r!}$	
	$\therefore \lim_{n \rightarrow \infty} \left( \sum_{r=0}^n \frac{1}{r!} - \frac{1}{0!} - \frac{1}{1!} \right) < \lim_{n \rightarrow \infty} \sum_{r=2}^n \frac{r-1}{r!} < \lim_{n \rightarrow \infty} \sum_{r=2}^n \frac{r^2 - r - 1}{r!}$	

	$e-2 < \frac{1}{2!} + \frac{2}{3!} + \frac{3}{4!} + \frac{4}{5!} + \dots < 2$	
	<b>Method 2</b>	
	Since $e = \frac{1}{0!} + \frac{1}{1!} + \frac{1}{2!} + \frac{1}{3!} + \frac{1}{4!} + \frac{1}{5!} + \dots$ So $e-2 = \frac{1}{2!} + \frac{1}{3!} + \frac{1}{4!} + \frac{1}{5!} + \dots < \frac{1}{2!} + \frac{2}{3!} + \frac{3}{4!} + \frac{4}{5!} + \dots$	
	And $\sum_{r=2}^{\infty} \frac{r-1}{r!} < \sum_{r=2}^{\infty} \frac{r^2-r-1}{r!}$	
	So $e-2 < \frac{1}{2!} + \frac{2}{3!} + \frac{3}{4!} + \frac{4}{5!} + \dots < 2$	
<b>9</b>	The position vectors of points $A, B, C$ with respect to the origin $O$ are given by $\mathbf{a}, \mathbf{b}$ and $\mathbf{c}$ respectively. The non-zero vectors $\mathbf{a}, \mathbf{b}$ and $\mathbf{c}$ satisfy the equation $\mathbf{a} + \mathbf{b} + \mathbf{c} = \mathbf{0}$ .	
	(i) By considering the plane $OAB$ or otherwise, explain clearly why $O, A, B$ and $C$ lies on the same plane. Show that $\mathbf{a} \times \mathbf{b} = \mathbf{b} \times \mathbf{c} = \mathbf{c} \times \mathbf{a}$ .	[4]
	(ii) Show that the area of triangle $ABC$ is given by $k \mathbf{a} \times \mathbf{b} $ where $k$ is a constant to be determined.	[3]
	(iii) If $\mathbf{b}$ is a unit vector and $\mathbf{a}$ is perpendicular to $\mathbf{b}$ , find the length of projection of $\vec{AC}$ onto $\vec{OB}$ . Given that the magnitude of $\vec{AC}$ is 2 units, deduce the angle between $\vec{AC}$ and $\vec{OA}$ .	[5]
	<b>Solution</b>	
	(i) Eqn of plane $OAB$ : $\mathbf{r} = \lambda\mathbf{a} + \mu\mathbf{b} \quad \lambda, \mu \in \mathbb{R}$	
	Since $\mathbf{c} = -\mathbf{a} - \mathbf{b}$ where $\lambda = \mu = -1$ , hence $C$ lies on plane $OAB$ . Thus $O, A, B$ and $C$ lies on the same plane.	
	OR $(\mathbf{a} \times \mathbf{b}) \cdot \mathbf{c} = (\mathbf{a} \times \mathbf{b}) \cdot [-(\mathbf{a} + \mathbf{b})]$ $= -(\mathbf{a} \times \mathbf{b}) \cdot \mathbf{a} - (\mathbf{a} \times \mathbf{b}) \cdot \mathbf{b}$ $= 0$ Thus $O, A, B$ and $C$ lies on the same plane.	
	Since $\mathbf{a} + \mathbf{b} + \mathbf{c} = \mathbf{0}$ , $\mathbf{b} = -\mathbf{a} - \mathbf{c}$	
	$\mathbf{a} \times \mathbf{b} = \mathbf{a} \times (-\mathbf{a} - \mathbf{c})$	
	$= -\mathbf{a} \times \mathbf{a} - \mathbf{a} \times \mathbf{c}$	
	$= \mathbf{c} \times \mathbf{a}$ (Q $\mathbf{a} \times \mathbf{a} = \mathbf{0}$ & $\mathbf{c} \times \mathbf{a} = -\mathbf{a} \times \mathbf{c}$ )	
	$\mathbf{b} \times \mathbf{c} = (-\mathbf{a} - \mathbf{c}) \times \mathbf{c}$	
	$= -\mathbf{a} \times \mathbf{c} - \mathbf{c} \times \mathbf{c}$	
	$= \mathbf{c} \times \mathbf{a}$ (Q $\mathbf{c} \times \mathbf{c} = \mathbf{0}$ & $\mathbf{c} \times \mathbf{a} = -\mathbf{a} \times \mathbf{c}$ )	
	$\therefore \mathbf{a} \times \mathbf{b} = \mathbf{b} \times \mathbf{c} = \mathbf{c} \times \mathbf{a}$ , shown	
	(ii) Area of triangle $ABC$	

[TURN OVER]

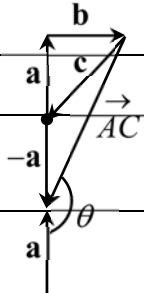
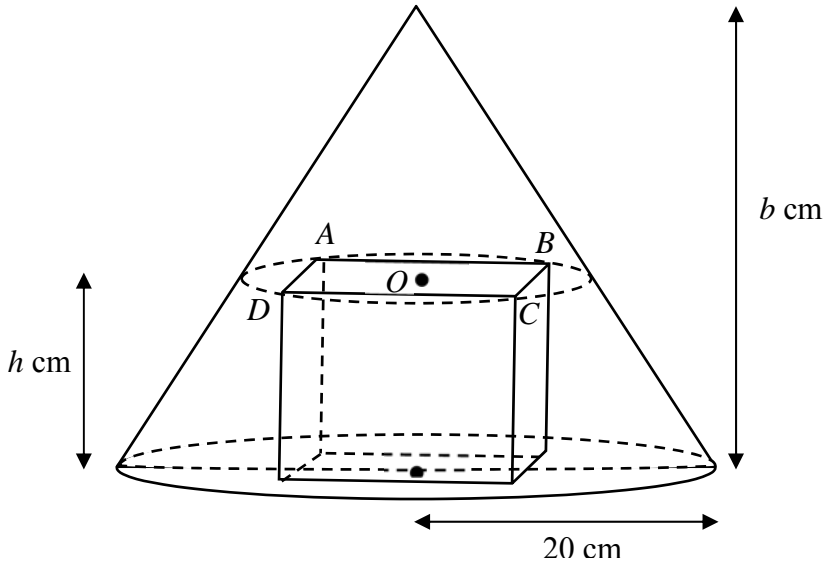

	$= \frac{1}{2} \left  \vec{AB} \times \vec{AC} \right $	
	$= \frac{1}{2} \left  (\mathbf{b} - \mathbf{a}) \times (\mathbf{c} - \mathbf{a}) \right $	
	$= \frac{1}{2} \left  \mathbf{b} \times \mathbf{c} - \mathbf{a} \times \mathbf{c} - \mathbf{b} \times \mathbf{a} + \mathbf{a} \times \mathbf{a} \right $	
	$= \frac{1}{2} \left  \mathbf{b} \times \mathbf{c} + \mathbf{c} \times \mathbf{a} + \mathbf{a} \times \mathbf{b} \right $	
	$= \frac{3}{2} \left  \mathbf{a} \times \mathbf{b} \right  \text{ where } k = \frac{3}{2} \text{ ( Since } \mathbf{a} + \mathbf{b} + \mathbf{c} = \mathbf{0}, \mathbf{a} \times \mathbf{b} = \mathbf{b} \times \mathbf{c} = \mathbf{c} \times \mathbf{a} \text{ )}$	
	(iii) $\left  \vec{AC} \cdot \hat{\mathbf{b}} \right  = \left  (\mathbf{c} - \mathbf{a}) \cdot \mathbf{b} \right $	
	$= \left  (-\mathbf{b} - 2\mathbf{a}) \cdot \mathbf{b} \right $	
	$= \left  - \mathbf{b} ^2 - 2\mathbf{a} \cdot \mathbf{b} \right $	
	$= 1 \quad (\text{Q } \mathbf{a} \cdot \mathbf{b} = 0,  \mathbf{b}  = 1)$	
	Let $\theta$ be the angle between $\vec{AC}$ and $\mathbf{a}$ .	
	$\theta = 180^\circ - \sin^{-1} \left( \frac{1}{2} \right)$	
	$= 150^\circ \text{ or } \frac{5\pi}{6} \text{ rad}$	
<b>10</b>	The diagram below shows a rectangular container of variable height $h$ cm, inscribed in a right circular cone with fixed height $b$ cm and a radius of 20 cm. The four corners of the rectangular container's upper surface $ABCD$ is always in contact with the conical surface. The point $O$ is at the centre of the rectangle $ABCD$ . The rectangular container is made with material of negligible thickness.	
		

	<p>(i) If the fixed angle <math>BOC</math> is <math>\theta</math>, show that the storage volume of the rectangular container in the shape of a cuboid is given by</p> $V = 800b^{-2} (b - h)^2 h \sin \theta.$	[3]
	<p>(ii) Find the value of <math>h</math> such that the rectangular container has a maximum storage volume, leaving your answer in terms of <math>b</math>.</p>	[5]
	<p>The rectangular container is opened at its upper surface <math>ABCD</math> and completely filled with a type of liquid perfume. A fragrance chemist placed the container in a room and allowed the liquid perfume to evaporate. It is known that the heat energy of the liquid perfume in the container, <math>E</math> joules, is related to the height of the container by the equation</p> $E = h - 3h^{\frac{1}{2}}.$	
	<p>(iii) Given that the perfume evaporates at a rate of 0.08 c every hour and that the value of <math>\theta</math> is <math>\frac{\pi}{6}</math>, calculate the rate of change of heat energy of the perfume when the height of the perfume in the rectangular container is <math>\frac{b}{5}</math> cm, leaving your answer in the form <math>p + q\left(\frac{5}{b}\right)^{\frac{3}{2}}</math>, where <math>p</math> and <math>q</math> are exact constants to be determined.</p>	[4]
	<b>Solution</b>	
	(i) Let the length of $OB$ be $r$ .	
	<b>Method 1</b>	
	$V = 4\left(r \sin \frac{\theta}{2}\right)\left(r \cos \frac{\theta}{2}\right)h$	
	$= 2r^2 h \sin \theta$	
	<b>Method 2</b>	
	$V = 2\left[\frac{1}{2}r^2 \sin \theta + \frac{1}{2}r^2 \sin(\pi - \theta)\right]h$	
	$= [r^2 \sin \theta + r^2 \sin(\pi - \theta)]h$	
	$= 2r^2 h \sin \theta \quad (\text{since } \sin(\pi - \theta) = \sin \theta)$	
	Using similar triangle,	
	$\frac{r}{20} = \frac{b - h}{b}$	
	$r = \frac{20}{b}(b - h)$	
	$V = 2\left(\frac{20}{b}\right)^2 (b - h)^2 h \sin \theta$	
	$= 800b^{-2} (b - h)^2 h \sin \theta \quad (\text{Shown})$	
	<p>(ii) <math>\frac{dV}{dh} = 800b^{-2} (b - h)^2 \sin \theta + 800b^{-2} h \sin \theta (2)(b - h)(-1)</math></p>	

**[TURN OVER]**

	$= 800b^{-2}(b-h)(\sin \theta)(b-h-2h)$	
	$= 800b^{-2}(\sin \theta)(b-h)(b-3h)$	
	Setting $\frac{dV}{dh} = 0$ ,	
	$800b^{-2}(\sin \theta)(b-h)(b-3h) = 0$	
	$(b-h)(b-3h) = 0$	
	$h = b$ (rejected since $h \neq b$ ) or $h = \frac{b}{3}$	
	<b>Method 1 (Using second derivative test)</b>	
	$\frac{d^2V}{dh^2} = 800b^{-2}(\sin \theta)[(b-h)(-3) + (b-3h)(-1)]$	
	$= 800b^{-2}(\sin \theta)(6h-4b)$	
	When $h = \frac{b}{3}$ , $\frac{d^2V}{dh^2} = 800b^{-2}(\sin \theta)(-2b) < 0$	
	Hence, $V$ is maximum when $h = \frac{b}{3}$ .	
	<b>Method 2 (Using first derivative test)</b>	
	$\frac{dV}{dh} = 800b^{-2}(\sin \theta)(b-h)(b-3h)$	
	When $h < \frac{b}{3}$ , $800b^{-2}(\sin \theta) > 0$ , $(b-h) > 0$ and $(b-3h) > 0$ , $\frac{dV}{dh} > 0$	
	When $h > \frac{b}{3}$ , $800b^{-2}(\sin \theta) > 0$ , $(b-h) > 0$ and $(b-3h) < 0$ , $\frac{dV}{dh} < 0$	
	Hence, $V$ is maximum when $h = \frac{b}{3}$ .	
	(iii) Since $\theta = \frac{\pi}{6}$ , $\frac{dV}{dh} = \frac{400}{b^2}(b-h)(b-3h)$	
	$\frac{dV}{dt} = \frac{dV}{dh} \times \frac{dh}{dt}$	
	When $h = \frac{b}{5}$ ,	
	$-0.08 = \frac{400}{b^2} \left(\frac{4}{5}b\right) \left(\frac{2}{5}b\right) \times \frac{dh}{dt}$	
	$\frac{dh}{dt} = -\frac{1}{1600}$	
	$E = h - 3h^{-\frac{1}{2}}$	
	$\frac{dE}{dh} = 1 + \frac{3}{2}h^{-\frac{3}{2}}$	

	$\frac{dE}{dt} = \frac{dE}{dh} \times \frac{dh}{dt}$	
	$= \left(1 + \frac{3}{2}h^{-\frac{3}{2}}\right) \left(-\frac{1}{1600}\right)$	
	$= \left[1 + \frac{3}{2}\left(\frac{b}{5}\right)^{-\frac{3}{2}}\right] \left(-\frac{1}{1600}\right)$	
	$= -\frac{1}{1600} - \frac{3}{3200} \left(\frac{5}{b}\right)^{\frac{3}{2}}$	
	Hence, $p = -\frac{1}{1600}$ , $q = -\frac{3}{3200}$	
<b>11</b>	<p>A charged particle is placed in a varying magnetic field. A researcher decides to fit a mathematical model for the path of the fast-moving charged particle under the influence of the magnetic field. The particle was observed for the first 1.5 seconds. The displacement of the particle measured with respect to the origin in the horizontal and vertical directions, at time <math>t</math> seconds, is denoted by the variables <math>x</math> and <math>y</math> respectively. It is given that when <math>t = 0</math>, <math>x = -\frac{1}{32}</math>, <math>y = 0</math> and <math>\frac{dx}{dt} = 3</math>. The variables are related by the differential equations</p> $(\cos t) \frac{dy}{dt} + y \sin t = 4 \cos^2 t - y^2 \quad \text{and} \quad \frac{d^2x}{dt^2} = \cos 3t \cos t .$	
	(i) Using the substitution $y = v \cos t$ , show that $\frac{dv}{dt} = 4 - v^2$ and hence find $y$ in terms of $t$ .	[7]
	(ii) Show that $x = -\frac{1}{32} \cos 4t - \frac{1}{8} \cos 2t + 3t + \frac{1}{8}$ .	[4]
	(iii) Sketch the path travelled by the particle for the first 1.5 seconds, labelling the coordinates of the end points of the path. The evaluation of the $y$ -intercept is not needed.	[2]
	<b>Solution</b>	
	(i) $y = v \cos t$	
	$\frac{dy}{dt} = -v \sin t + \frac{dv}{dt} \cos t$	
	$(\cos t) \frac{dy}{dt} + y \sin t = 4 \cos^2 t - y^2$	
	$(\cos t) \left(-v \sin t + \frac{dv}{dt} \cos t\right) + (v \cos t) \sin t = 4 \cos^2 t - v^2 \cos^2 t$	

[TURN OVER]

	$\frac{dv}{dt}(\cos^2 t) = (\cos^2 t)(4 - v^2)$	
	$\frac{dv}{dt} = 4 - v^2$ (Shown)	
	$\int \frac{1}{4 - v^2} dv = \int 1 dt$	
	$\int \frac{1}{2^2 - v^2} dv = \int 1 dt$	
	$\frac{1}{2(2)} \ln \left  \frac{2+v}{2-v} \right  = t + d$	
	$\left  \frac{2+v}{2-v} \right  = e^{4t+4d}$	
	$\frac{2+v}{2-v} = \pm e^{4t+4d}$	
	$\frac{2+v}{2-v} = Ae^{4t}$ , where $A = \pm e^{4d}$	
	$2+v = 2Ae^{4t} - Ave^{4t}$	
	$v + Ave^{4t} = 2(Ae^{4t} - 1)$	
	$v = \frac{2(Ae^{4t} - 1)}{Ae^{4t} + 1}$	
	$\frac{y}{\cos t} = \frac{2(Ae^{4t} - 1)}{Ae^{4t} + 1}$	
	$y = \frac{2(Ae^{4t} - 1)\cos t}{Ae^{4t} + 1}$	
	When $t = 0$ , $y = 0$	
	$0 = \frac{2(A-1)}{A+1}$	
	$A = 1$	
	$y = \frac{2(e^{4t} - 1)\cos t}{e^{4t} + 1}$	
	<b>(ii)</b> $\frac{d^2x}{dt^2} = \cos 3t \cos t$	
	$\frac{d^2x}{dt^2} = \frac{1}{2}(\cos 4t + \cos 2t)$	
	$\frac{dx}{dt} = \frac{1}{2} \int \cos 4t + \cos 2t dt$	
	$= \frac{1}{2} \left( \frac{1}{4} \sin 4t + \frac{1}{2} \sin 2t \right) + c$	
	$= \frac{1}{8} \sin 4t + \frac{1}{4} \sin 2t + c$	

	When $t = 0$ , $\frac{dx}{dt} = 3$	
	$3 = \frac{1}{8} \sin 4(0) + \frac{1}{4} \sin 2(0) + c$	
	$c = 3$	
	$x = \int \frac{1}{8} \sin 4t + \frac{1}{4} \sin 2t + 3 dt$	
	$x = -\frac{1}{32} \cos 4t - \frac{1}{8} \cos 2t + 3t + k$	
	When $t = 0$ , $x = -\frac{1}{32}$	
	$-\frac{1}{32} = -\frac{1}{32} \cos 4(0) - \frac{1}{8} \cos 2(0) + 3(0) + k$	
	$k = \frac{1}{8}$	
	Hence, $x = -\frac{1}{32} \cos 4t - \frac{1}{8} \cos 2t + 3t + \frac{1}{8}$	
	(iii)	
	<p>A graph showing a curve on a Cartesian coordinate system. The x-axis is horizontal and the y-axis is vertical. The curve starts at a point on the x-axis labeled <math>(-\frac{1}{32}, 0)</math>. It rises to a peak and then descends to a point labeled <math>(4.72, 0.141)</math>.</p>	

**THE END**

**[TURN OVER]**



**SERANGOON JUNIOR COLLEGE**  
**2018 JC2 PRELIMINARY EXAMINATION**  
**MATHEMATICS**

**Higher 2**

**9758/2**

**17 Sept 2018**

**3 hours**

Additional materials: Writing paper

List of Formulae (MF 26)

**TIME** : 3 hours

**READ THESE INSTRUCTIONS FIRST**

Write your name and class on the cover page and on all the work you hand in.

Write in blue or black pen on both sides of the paper.

You may use a soft pencil for any diagrams or graphs.

Do not use staples, paper clips, highlighters, glue or correction fluid.

Answer **all** the questions.

Give non-exact numerical answers correct to 3 significant figures, or 1 decimal place in the case of angles in degrees, unless a different level of accuracy is specified in the question.

You are expected to use a graphic calculator.

Unsupported answers from a graphic calculator are allowed unless a question specifically states otherwise.

Where unsupported answers from a graphic calculator are not allowed in a question, you are required to present the mathematical steps using mathematical notations and not calculator commands.

You are reminded of the need for clear presentation in your answers.

The number of marks is given in brackets [ ] at the end of each question or part question.

At the end of the examination, fasten all your work securely together.

Total marks for this paper is 100 marks

---

**This question paper consists of 7 printed pages (inclusive of this page) and 1 blank page.**

**[TURN OVER]**

## Section A: Pure Mathematics [40 marks].

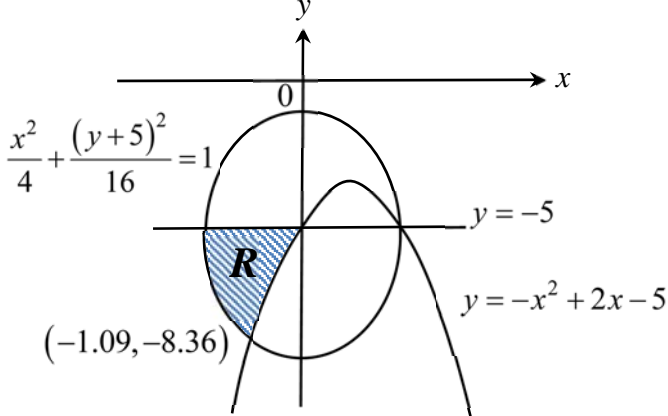
1	<p><math>R</math> is the region enclosed by the line <math>y = -5</math> and the curves <math>y = -x^2 + 2x - 5</math> and <math>\frac{x^2}{4} + \frac{(y+5)^2}{16} = 1</math> as shown in the diagram below.</p>	
		
	<p>Find the volume generated by region <math>R</math> when it is rotated <math>2\pi</math> radians about the <math>x</math>-axis. Leave your answer correct to 2 decimal places.</p>	[3]
	<b>Solution</b>	
	<p>Required volume <math>= \pi \int_{-2}^{-1.09} \left(-5 - \sqrt{16 - 4x^2}\right)^2 dx + \pi \int_{-1.09}^0 \left(-x^2 + 2x - 5\right)^2 dx - \pi(25)(2)</math>  OR  <math>= \pi \int_{-2}^{-1.09} \left(-5 - \sqrt{16 - 4x^2}\right)^2 dx + \pi \int_{-1.09}^0 \left(-x^2 + 2x - 5\right)^2 dx - \pi \int_{-2}^0 (-5)^2 dx</math></p>	
	<p><math>= 146.91</math></p>	
	<p>Using Shell method</p> $\text{Vol} = 2\pi \int_{-8.36}^{-5} -y \left( 1 - \sqrt{-y-4} + \sqrt{4 - \frac{(y+5)^2}{4}} \right) dy$	
	<p><math>= 146.91</math></p>	
2	<p>A curve has parametric equations</p> $x = \tan \theta, \quad y = 2 \sec \theta \quad \text{for } 0 \leq \theta < 2\pi.$	
	<p>The equation of the tangent to the curve at the point <math>P</math> with parameter <math>p</math> is given by <math>y = (2 \sin p)x + 2 \cos p</math>.</p>	
	<p>(i) The tangent at <math>P</math> meets the <math>x</math> and <math>y</math> axes at the points <math>A</math> and <math>B</math> respectively. Find the Cartesian equation of the locus of the mid-point of <math>AB</math> as <math>p</math> varies.</p>	[3]
	<p>(ii) The tangent at <math>P</math> meets the line <math>y = 2x</math> at the point <math>S</math> and the line <math>y = -2x</math> at the point <math>T</math>. Show that the area of the triangle <math>OST</math> is independent of <math>p</math>, where <math>O</math> is the origin.</p>	[4]
	<b>Solution</b>	
	<p>(i) Coordinates of <math>A</math>: <math>(-\cot p, 0)</math></p>	
	<p>Coordinates of <math>B</math>: <math>(0, 2 \cos p)</math></p>	



	Midpoint of $AB: \left(-\frac{\cot p}{2}, \cos p\right)$	
	So let $x = -\frac{\cot p}{2}$ and $y = \cos p$	
	$\tan p = -\frac{1}{2x}$ and $\sec p = \frac{1}{y}$	
	Since $1 + \tan^2 p = \sec^2 p$	
	$1 + \frac{1}{4x^2} = \frac{1}{y^2}$	
	<b>(ii)</b> To find the coordinates of $S$ : $2x = (2 \sin p)x + 2 \cos p$	
	$\therefore x = \frac{\cos p}{1 - \sin p}$ and $y = \frac{2 \cos p}{1 - \sin p}$	
	To find the coordinates of $T$ : $-2x = (2 \sin p)x + 2 \cos p$	
	$\therefore x = \frac{-\cos p}{1 + \sin p}$ and $y = \frac{2 \cos p}{1 + \sin p}$	
	<b>Method 1</b>	
	Hence area of triangle $OST$ $= \frac{1}{2} \sqrt{\left(\frac{\cos p}{1 - \sin p}\right)^2 + \left(\frac{2 \cos p}{1 - \sin p}\right)^2} \sqrt{\left(\frac{-\cos p}{1 + \sin p}\right)^2 + \left(\frac{2 \cos p}{1 + \sin p}\right)^2} \sin\left(2 \tan^{-1} \frac{1}{2}\right)$	
	– is for using formula with the correct angle used.	
	$= \frac{1}{2} \frac{\cos^2 p}{(1 - \sin p)(1 + \sin p)} \sqrt{5} \sqrt{5} \left[2 \sin\left(\tan^{-1} \frac{1}{2}\right) \cos\left(\tan^{-1} \frac{1}{2}\right)\right]$	
	$= \frac{5}{2} \left(\frac{\cos^2 p}{1 - \sin^2 p}\right) \left(2 \times \frac{2}{\sqrt{5}} \times \frac{1}{\sqrt{5}}\right)$ $= 2$	
	<b>Method 2</b>	
	Hence area of triangle $OST$ $= \frac{1}{2} \sqrt{\left(\frac{\cos p}{1 - \sin p}\right)^2 + \left(\frac{2 \cos p}{1 - \sin p}\right)^2} \sqrt{\left(\frac{-\cos p}{1 + \sin p}\right)^2 + \left(\frac{2 \cos p}{1 + \sin p}\right)^2} \sin\left(\tan^{-1} \frac{4}{3}\right)$	
	– is for using formula with the correct angle used.	
	$= \frac{1}{2} \frac{\cos^2 p}{(1 - \sin p)(1 + \sin p)} \sqrt{5} \sqrt{5} \sin\left(\tan^{-1} \frac{4}{3}\right)$	
	$= \frac{5}{2} \left(\frac{\cos^2 p}{1 - \sin^2 p}\right) \left(\frac{4}{5}\right)$ $= 2$	
<b>3</b>	Given that $\ln y = e^{\tan^{-1} x}$ , show that $(1 + x^2) \frac{d^2 y}{dx^2} = (\ln y + 1 - 2x) \frac{dy}{dx}$ .	[2]
	<b>(i)</b> Find the Maclaurin's series for $y$ up to and including the term in $x^3$ .	[4]

	(ii) Deduce the Maclaurin's series for $y$ , where $\ln y = e^{\tan^{-1} x} + x - 1$ , up to and including the term in $x^3$ .	[3]
	<b>Solution</b>	
	$\ln y = e^{\tan^{-1} x}$	
	$\frac{1}{y} \frac{dy}{dx} = \frac{1}{1+x^2} e^{\tan^{-1} x}$	
	$(1+x^2) \frac{dy}{dx} = y \ln y$	
	$(1+x^2) \frac{d^2 y}{dx^2} + 2x \frac{dy}{dx} = \ln y \frac{dy}{dx} + \frac{dy}{dx}$	
	$(1+x^2) \frac{d^2 y}{dx^2} = (\ln y + 1 - 2x) \frac{dy}{dx}$	
	(i) $(1+x^2) \frac{d^3 y}{dx^3} + 2x \frac{d^2 y}{dx^2} = (\ln y + 1 - 2x) \frac{d^2 y}{dx^2} + \frac{dy}{dx} \left( \frac{1}{y} \frac{dy}{dx} - 2 \right)$	
	When $x = 0$ ,	
	$y = e$ , $\frac{dy}{dx} = e$ , $\frac{d^2 y}{dx^2} = 2e$ and $\frac{d^3 y}{dx^3} = 3e$	
	So the Maclaurin series of $y$ is	
	$y = e + ex + ex^2 + \frac{1}{2}ex^3 + \dots$	
	(ii) $y = e^{e^{\tan^{-1} x} + x - 1} = e^{e^{\tan^{-1} x}} \cdot e^x \cdot e^{-1}$	
	$y = e^{e^{\tan^{-1} x} + x - 1} = \left( e + ex + ex^2 + \frac{ex^3}{2} + \dots \right) \cdot \left( 1 + x + \frac{x^2}{2} + \frac{x^3}{6} + \dots \right) \cdot e^{-1}$	
	$= 1 + x + x^2 + \frac{x^3}{2} + x + x^2 + x^3 + \frac{x^2}{2} + \frac{x^3}{2} + \frac{x^3}{6} + \dots$	
	$= 1 + 2x + \frac{5}{2}x^2 + \frac{13}{6}x^3 + \dots$	
<b>4</b>	Given that the equation $f(z) = 2z^3 + az^2 + (2a-4)z + (2a-8) = 0$ has no real solution, explain clearly why $a$ is not a real number.	[2]
	(i) It is known that $f$ has a factor $(2z + i)$ , find $a$ . Hence find all the roots of $f(z) = 0$ , showing your workings clearly.	[4]
	(ii) Deduce the roots of the equation $2 - \frac{a}{w} + \frac{(2a-4)}{w^2} - \frac{2a-8}{w^3} = 0$ , where $a$ takes the value obtained in (i).	[2]
	<b>Solution</b>	
	If all coefficients are real, then by conjugate root theorem, roots will occur in conjugate pairs. As $f$ is a polynomial of degree 3, it would mean that it must	

	have either 3 real roots or it will be having 1 real root with a pair of conjugate roots.	
	But it is given that $f(z) = 0$ has no real solution and so it must therefore mean that at least one of the coefficients is a complex number. Hence $a$ is not a real number.	
	(i) $f\left(-\frac{i}{2}\right) = 2\left(-\frac{i}{2}\right)^3 + a\left(-\frac{i}{2}\right)^2 + (2a-4)\left(-\frac{i}{2}\right) + 2a-8 = 0$	
	$\frac{i}{4} - \frac{a}{4} - ai + 2i + 2a - 8 = 0$	
	$8 - \frac{9}{4}i = a\left(\frac{7}{4} - i\right)$	
	$= 4 + i$	
	So $f(z) = 2z^3 + (4+i)z^2 + (4+2i)z + 2i = (2z+i)(z^2 + 2z + 2)$	
	For $f(z) = 0 \Rightarrow (2z+i)(z^2 + 2z + 2) = 0$	
	Consider $z^2 + 2z + 2 = 0$ ,	
	$z = \frac{-2 \pm \sqrt{4-8}}{2}$	
	$z = -1 \pm i$	
	Hence the roots are $-1+i$ , $-1-i$ and $-\frac{i}{2}$	
	(ii) Since $2z^3 + az^2 + (2a-4)z + 2a-8 = 0$ ,	
	$\Rightarrow 2 + \frac{a}{z} + \frac{2a-4}{z^2} + \frac{2a-8}{z^3} = 0$	
	Replace $z$ by $-w$	
	$\Rightarrow 2 - \frac{a}{w} + \frac{2a-4}{w^2} - \frac{2a-8}{w^3} = 0$	
	So the roots of this equations are $1-i$ , $1+i$ and $\frac{i}{2}$	
<b>5</b>	A hollow metallic ramp, in the shape of a prism, is constructed for the marching contingent to march onto to reach an elevated platform from the ground during the national day parade.	
	The diagram below shows the prism with $O$ as the origin of position vectors and the unit vectors $\mathbf{i}$ , $\mathbf{j}$ and $\mathbf{k}$ are parallel to $OA$ , $OC$ and $OE$ respectively. It is given that $OE = CD = 1$ m, $OA = CB = 2$ m and $OC = AB = ED = 4$ m.	

	A laser beam in the form of a line $l$ has Cartesian equation $\frac{a+x}{2} = z, y=1$ , where $a \in \mathbb{R}$ , is emitted onto the plane $ABDE$ .	
	(i) Find, in terms of $a$ , the coordinates of the point of intersection, $M$ , of the laser beam and the plane $ABDE$ .	[4]
	For the following parts of the question assume $a = 0$ .	
	(ii) The laser beam is reflected about the plane $ABDE$ . By finding the foot of perpendicular from $Q(0,1,0)$ to the plane $ABDE$ , find the equation of the reflected beam.	[5]
	(iii) The path traced out by an ant crawling on the floor $OABC$ is given by $\mathbf{r} = \begin{pmatrix} 2 \\ 0 \\ 0 \end{pmatrix} + \beta \begin{pmatrix} -1 \\ 2 \\ 0 \end{pmatrix}, \beta \in \mathbb{R}$ . Let $P$ be the point on the path, located under the ramp, whereby the ant is equidistant between the planes $ABDE$ and $OCDE$ . Find the position vector of point $P$ exactly.	[4]
	<b>Solution</b>	
	(i) line $l: \mathbf{r} = \begin{pmatrix} -a \\ 1 \\ 0 \end{pmatrix} + \lambda \begin{pmatrix} 2 \\ 0 \\ 1 \end{pmatrix}, a, \lambda \in \mathbb{R}$	
	normal vector of plane $ABDE, \mathbf{n} = \begin{pmatrix} 0 \\ 1 \\ 0 \end{pmatrix} \times \left[ \begin{pmatrix} 2 \\ 0 \\ 0 \end{pmatrix} - \begin{pmatrix} 0 \\ 0 \\ 1 \end{pmatrix} \right] = \begin{pmatrix} -1 \\ 0 \\ -2 \end{pmatrix} = - \begin{pmatrix} 1 \\ 0 \\ 2 \end{pmatrix}$	
	plane $ABDE: \mathbf{r} \cdot \begin{pmatrix} 1 \\ 0 \\ 2 \end{pmatrix} = \begin{pmatrix} 0 \\ 0 \\ 1 \end{pmatrix} \cdot \begin{pmatrix} 1 \\ 0 \\ 2 \end{pmatrix} = 2$	
	For point of intersection,	
	$\begin{pmatrix} -a+2\lambda \\ 1 \\ \lambda \end{pmatrix} \cdot \begin{pmatrix} 1 \\ 0 \\ 2 \end{pmatrix} = 2$	
	$\lambda = \frac{2+a}{4}$	
	$\mathbf{OM} = \begin{pmatrix} -a + \frac{2+a}{2} \\ 1 \\ \frac{2+a}{4} \end{pmatrix} = \begin{pmatrix} \frac{2-a}{4} \\ 1 \\ \frac{2+a}{4} \end{pmatrix}$ Coordinates are $\left( \frac{2-a}{4}, 1, \frac{2+a}{4} \right)$	

	(ii) As $a = 0$ , $\vec{OM} = \frac{1}{2} \begin{pmatrix} 2 \\ 2 \\ 1 \end{pmatrix}$	
	Let $F$ be the foot of perpendicular from $Q$ to the plane $ABDE$	
	Equation of line $QF$ is $\mathbf{r} = \begin{pmatrix} 0 \\ 1 \\ 0 \end{pmatrix} + \mu \begin{pmatrix} 1 \\ 0 \\ 2 \end{pmatrix}, \mu \in \mathbb{R}$	
	$\vec{OF} = \begin{pmatrix} \mu \\ 1 \\ 2\mu \end{pmatrix}$ for some $\mu \in \mathbb{R}$ Missing out “for some $\mu$ ” anywhere – P	
	$\begin{pmatrix} \mu \\ 1 \\ 2\mu \end{pmatrix} \cdot \begin{pmatrix} 1 \\ 0 \\ 2 \end{pmatrix} = 2$	
	$\mu = \frac{2}{5}$	
	$\therefore \vec{OF} = \frac{1}{5} \begin{pmatrix} 2 \\ 5 \\ 4 \end{pmatrix}$	
	Let $Q'$ be the point of reflection of point $Q$ about plane $ABDE$ .	
	$\vec{OQ}' = 2\vec{OF} - \vec{OQ} = \begin{pmatrix} 4/5 \\ 2 \\ 8/5 \end{pmatrix} - \begin{pmatrix} 0 \\ 1 \\ 0 \end{pmatrix} = \begin{pmatrix} 4/5 \\ 1 \\ 8/5 \end{pmatrix}$	
	$\vec{MQ}' = \vec{OQ}' - \vec{OM} = \begin{pmatrix} 4/5 \\ 1 \\ 8/5 \end{pmatrix} - \begin{pmatrix} 1 \\ 1 \\ 1/2 \end{pmatrix} = \begin{pmatrix} -1/5 \\ 0 \\ 11/10 \end{pmatrix} = \frac{1}{10} \begin{pmatrix} -2 \\ 0 \\ 11 \end{pmatrix}$	
	Equation of line of reflection of the laser beam:	
	$\mathbf{r} = \begin{pmatrix} 4/5 \\ 1 \\ 8/5 \end{pmatrix} + \alpha \begin{pmatrix} -2 \\ 0 \\ 11 \end{pmatrix}, \alpha \in \mathbb{R}$ OR $\mathbf{r} = \frac{1}{2} \begin{pmatrix} 2 \\ 2 \\ 1 \end{pmatrix} + \alpha \begin{pmatrix} -2 \\ 0 \\ 11 \end{pmatrix}, \alpha \in \mathbb{R}$	
	(iii) Equation of line $AC$ : $\mathbf{r} = \begin{pmatrix} 2 \\ 0 \\ 0 \end{pmatrix} + \beta \begin{pmatrix} -1 \\ 2 \\ 0 \end{pmatrix}, \beta \in \mathbb{R}$	

	$\vec{OP} = \begin{pmatrix} 2-\beta \\ 2\beta \\ 0 \end{pmatrix} \text{ for some } \beta$ <p>Missing “for some <math>\beta</math>” – P</p>	
	$\frac{ \vec{OP} \cdot \mathbf{n}_{OCDE} }{ \mathbf{n}_{OCDE} } = \frac{ \vec{EP} \cdot \mathbf{n}_{ABDE} }{ \mathbf{n}_{ABDE} }$	
	$\frac{\begin{pmatrix} 2-\beta \\ 2\beta \\ 0 \end{pmatrix} \cdot \begin{pmatrix} 1 \\ 0 \\ 0 \end{pmatrix}}{\begin{pmatrix} 1 \\ 0 \\ 0 \end{pmatrix}} = \frac{\begin{pmatrix} 2-\beta \\ 2\beta \\ -1 \end{pmatrix} \cdot \begin{pmatrix} 1 \\ 0 \\ 2 \end{pmatrix}}{\begin{pmatrix} 1 \\ 0 \\ 2 \end{pmatrix}} \quad \text{OR} \quad \frac{\begin{pmatrix} 2-\beta \\ 2\beta \\ 0 \end{pmatrix} \cdot \begin{pmatrix} 1 \\ 0 \\ 0 \end{pmatrix} - 0}{\begin{pmatrix} 1 \\ 0 \\ 0 \end{pmatrix}} = \frac{\begin{pmatrix} 2-\beta \\ 2\beta \\ 0 \end{pmatrix} \cdot \begin{pmatrix} 1 \\ 0 \\ 2 \end{pmatrix} - 2}{\begin{pmatrix} 1 \\ 0 \\ 2 \end{pmatrix}}$	
	$ 2-\beta  = \left  \frac{2-\beta-2}{\sqrt{5}} \right $	
	$2-\beta = \pm \frac{\beta}{\sqrt{5}} \quad \text{OR} \quad 5(2-\beta)^2 = \beta^2$ $2\sqrt{5} - \beta\sqrt{5} = \pm\beta \quad (2\sqrt{5} - \sqrt{5}\beta - \beta)(2\sqrt{5} - \sqrt{5}\beta + \beta) = 0$	
	$\therefore \frac{2\sqrt{5}}{\sqrt{5}+1} \quad \text{or} \quad \frac{2\sqrt{5}}{\sqrt{5}-1}$	
	$\frac{2\sqrt{5}(\sqrt{5}-1)}{4} \quad \text{or} \quad \frac{2\sqrt{5}(\sqrt{5}+1)}{4}$	
	$\beta = \frac{5 \pm \sqrt{5}}{2}$	
	$\vec{OP} = \frac{1}{2} \begin{pmatrix} -1-\sqrt{5} \\ 10+2\sqrt{5} \\ 0 \end{pmatrix} \text{ (rejected since it gives a point outside of the ramp)}$ <p>Hence <math display="block">\vec{OP} = \frac{1}{2} \begin{pmatrix} \sqrt{5}-1 \\ 10-2\sqrt{5} \\ 0 \end{pmatrix}</math></p>	

## Section B: Statistics [60 marks]

6	A jackfruit farm produces 2 types of jackfruit pulps namely Grade A and Grade B. The pulps are randomly packed into boxes of 8.																									
	The probability that a box contains at most 3 Grade A jackfruit pulps is 0.00245.																									
	A fruit trading wholesaler places a monthly order of 1000 boxes of jackfruit pulps for 5 years. Find the approximate probability that the mean number of boxes that contain at most 3 Grade A jackfruit pulps in a month is more than 3. [You may assume that there are 12 months in a year.]	[4]																								
	<b>Solution</b>																									
	Let $X$ be the r.v. “number of boxes that contain at most 3 Grade A jackfruit pulps in a box out of 1000 boxes”																									
	$X : B(1000, 0.00245)$																									
	$E(X) = 1000(0.00245) = 2.45$ $\text{Var}(X) = 2.45(1 - 0.00245) = 2.444$																									
	In 5 years, there are 60 months altogether.																									
	Mean number of boxes with at most 3 Grade A jackfruit pulps is $\bar{X} = \frac{X_1 + X_2 + X_3 + \dots + X_{60}}{60}$																									
	Since sample size is large, by Central Limit Theorem, $\bar{X} : N\left(2.45, \frac{2.444}{60}\right)$ approximately																									
	From GC, $P(\bar{X} > 3) = 0.00321$ (correct to 3 sig fig)																									
7	A player throws an unbiased six-sided die and the number shown on the top face is noted. If it is not a six, the score is the number shown on the top face. If it is a six, he throws the die a second time and the score is the total score obtained from his two throws. The player has at most two throws.																									
	(i) Construct the probability distribution table on the score for the player.	[2]																								
	Given that the expected player’s score is $\frac{49}{12}$ ,																									
	(ii) find the exact value of the variance of the player’s score, showing your workings clearly.	[3]																								
	<b>Solution</b>																									
	(i) Let $X$ be the random variable “total score of the player”.																									
	<table border="1"> <tbody> <tr> <td><math>x</math></td> <td>1</td> <td>2</td> <td>3</td> <td>4</td> <td>5</td> <td>7</td> <td>8</td> <td>9</td> <td>10</td> <td>11</td> <td>12</td> </tr> <tr> <td><math>P(X = x)</math></td> <td><math>\frac{1}{6}</math></td> <td><math>\frac{1}{6}</math></td> <td><math>\frac{1}{6}</math></td> <td><math>\frac{1}{6}</math></td> <td><math>\frac{1}{6}</math></td> <td><math>\frac{1}{36}</math></td> <td><math>\frac{1}{36}</math></td> <td><math>\frac{1}{36}</math></td> <td><math>\frac{1}{36}</math></td> <td><math>\frac{1}{36}</math></td> <td><math>\frac{1}{36}</math></td> </tr> </tbody> </table>	$x$	1	2	3	4	5	7	8	9	10	11	12	$P(X = x)$	$\frac{1}{6}$	$\frac{1}{6}$	$\frac{1}{6}$	$\frac{1}{6}$	$\frac{1}{6}$	$\frac{1}{36}$	$\frac{1}{36}$	$\frac{1}{36}$	$\frac{1}{36}$	$\frac{1}{36}$	$\frac{1}{36}$	
$x$	1	2	3	4	5	7	8	9	10	11	12															
$P(X = x)$	$\frac{1}{6}$	$\frac{1}{6}$	$\frac{1}{6}$	$\frac{1}{6}$	$\frac{1}{6}$	$\frac{1}{36}$	$\frac{1}{36}$	$\frac{1}{36}$	$\frac{1}{36}$	$\frac{1}{36}$	$\frac{1}{36}$															
	We can check that the total probability is 1.																									
	(ii)																									

	$E(X^2) = \sum x^2 P(X = x)$ $= (1)^2 \left(\frac{1}{6}\right) + (2)^2 \left(\frac{1}{6}\right) + (3)^2 \left(\frac{1}{6}\right) + (4)^2 \left(\frac{1}{6}\right) + (5)^2 \left(\frac{1}{6}\right)$ $+ (7)^2 \left(\frac{1}{36}\right) + (8)^2 \left(\frac{1}{36}\right) + (9)^2 \left(\frac{1}{36}\right) + (10)^2 \left(\frac{1}{36}\right) + (11)^2 \left(\frac{1}{36}\right) + (12)^2 \left(\frac{1}{36}\right)$	
	$= \frac{889}{36}$	
	$\text{Var}(X) = E(X^2) - [E(X)]^2$ $= \frac{889}{36} - \left(\frac{49}{12}\right)^2$	
	$= \frac{385}{48}$	
<b>8</b>	The length of time that Somesong phones last in between charges has a normal distribution with mean 20 hours and standard deviation 2 hours. The length of time that Apfel phones last in between charges has a normal distribution with mean $\mu$ hours and standard deviation $\sigma$ hours.	
	(a) The average length of time two randomly chosen Somesong phones and one randomly chosen Apfel phone will last in between charges is equally likely to be less than 19 hours or more than 23 hours, with the probability known to be 0.02275.	
	(i) Calculate the values of $\mu$ and $\sigma$ .	[3]
	(ii) Find the probability that twice the length of time a Somesong phone lasts in between charges differs from 40 hours by at least 2 hours.	[2]
	(b) Six randomly chosen Somesong phones are examined. Find the probability that the sixth Somesong phone is the fourth Somesong phone that lasts more than 22 hours in between charges.	[2]
	<b>Solution</b>	
	<p>(a) Let <math>X</math> denote the length of time that a randomly chosen Somesong phone lasts in between charges.</p> $X \sim N(20, 4)$ <p>Let <math>Y</math> denote the length of time that a randomly chosen Apfel phones lasts in between charges.</p> $Y \sim N(\mu, \sigma^2)$ <p>Let <math>W = \frac{X_1 + X_2 + Y}{3}</math></p> $W \sim N\left(\frac{40 + \mu}{3}, \frac{8 + \sigma^2}{9}\right)$	
	(i) By symmetry,	



	$\frac{40 + \mu}{3} = \frac{19 + 23}{2} = 21$ $\mu = 23$	
	<p>So, <math>W \sim N\left(21, \frac{8 + \sigma^2}{9}\right)</math></p> $P(W < 19) = 0.02275$ $P\left(Z < \frac{-6}{\sqrt{8 + \sigma^2}}\right) = 0.02275$ $\frac{-6}{\sqrt{8 + \sigma^2}} = -2$ $\sigma = 1$	
	<p>(ii) <math>2X \sim N(40, 16)</math></p> $P( 2X - 40  \geq 2)$ $= P(2X \geq 42) + P(2X \leq 38)$ $= 0.617$	
	(b) $P(X > 22) = 0.158655$	
	<p>Required probability</p> $= \binom{5}{3} (0.158655)^3 (1 - 0.158655)^2 (0.158655)$ $= 0.00449$	
<b>9</b>	<p>A customer wishes to investigate the shelf life of the durian puffs produced by a baker before they turn bad when placed at room temperature and pressure. It is assumed that the shelf life of the durian puffs are independent of one another. Based on past records, the baker claims that the mean shelf life of the durian puffs is at least 8 hours. To test this claim, the customer recorded the shelf life of 55 randomly chosen durian puffs and found that its mean is 7.4 hours and standard deviation is 2.6 hours.</p>	
	(i) Carry out a test, to determine whether there is any evidence to doubt the baker's claim at 5% significance level.	[5]
	(ii) Explain, in the context of the question, the meaning of 'at 5% significance level'.	[1]
	(iii) Suppose the population standard deviation is 3.2 hours now and the baker claims that the mean shelf life the durian puffs is 8 hours. A new sample of 10 durian puffs is taken. Using this sample, the customer conducts another test and found that the baker's claim is not rejected at the 5% significance level. Stating a necessary assumption for the test, find the set of values that the sample mean shelf life, $\bar{y}$ , can take.	[4]
	<b>Solution</b>	
	(i) Unbiased estimate of population variance = $\frac{55}{54} (2.6)^2 = 6.885185$	

	Let $\mu$ be the average shelf life of the durian puffs when placed at room temperature and pressure. Let $X$ be the random variable “the shelf life of a randomly chosen durian puff”.	
	To Test $H_0: \mu = 8$ Against $H_1: \mu < 8$	
	Left tailed z-test at 5% level of significance	
	Under $H_0$ , since sample size = 55 is large, by Central Limit Theorem,	
	$\bar{X} : N\left(8, \frac{6.885185}{55}\right)$ approximately	
	From the G.C, $p$ value = 0.0450 (Accept value of higher accuracy)	
	Since $p$ -value = 0.0450 < 0.05, we reject $H_0$ and conclude that there is sufficient evidence that the mean shelf life of the durian puff is less than 8 hours at 5% significance level.	
	(ii) There is a probability of 0.05 of concluding that the mean shelf life of the durian puffs is less than 8 hours when in fact it is 8 hours.	
	(iii) Assume that the shelf life of the durian puffs follows a normal distribution. Let $Y$ denote the shelf life of a randomly chosen durian puff.	
	$\bar{Y} : N\left(8, \frac{3.2^2}{10}\right)$	
	To Test $H_0: \mu = 8$ Against $H_1: \mu \neq 8$	
	2-tailed z-test at 5% level of significance	
	Since $H_0$ is not rejected,	
	$-1.96 < \frac{\bar{x} - 8}{\left(\frac{3.2}{\sqrt{10}}\right)} < 1.96$	
	$6.02 < \bar{x} < 9.98$	
	Set of values of $\bar{x}$ is $\{\bar{x} \in \mathbb{R} : 6.02 < \bar{x} < 9.98\}$	
<b>10</b>	(a) A group of twelve people consists of one pair of sisters, one set of three brothers, a family of three and 4 others.	
	(i) The twelve people are grouped into three groups of 4. Find the number of ways where the family of three are together.	[2]
	(ii) The twelve people are arranged randomly in a line. Find the number of ways that the sisters are not together and the brothers are all separated.	[3]
	(b) For events $A$ and $B$ , it is given that $P(A) = \frac{11}{20}$ , $P(B) = \frac{2}{5}$ and $P(A \cap B) = \frac{1}{4}$ .	
	(i) Find the probability where event $A$ occurs or event $B$ occurs but not both.	[1]

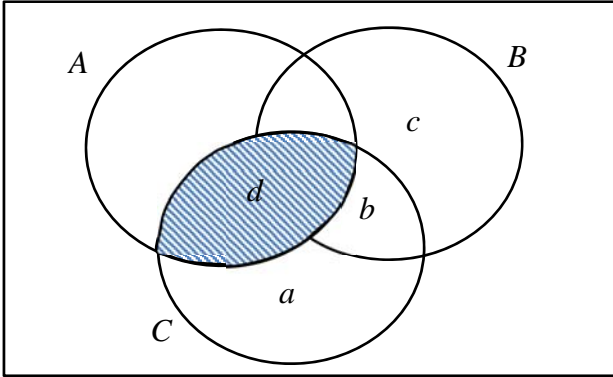
	(ii) Find the probability where event $B$ has occurred but not $A$ .	[1]
	For a third event $C$ , it is given that $P(C) = \frac{1}{2}$ and that $A$ and $C$ are independent,	
	(iii) Find the range of values of $P(A' \cap B' \cap C)$ .	[3]
	<b>Solution</b>	
	(ai) Number of ways = $\frac{3!}{2!} \binom{9}{4} \binom{5}{4}$	
	= 1890	
	– for selecting the 2 groups of 4 and arrange them i.e. $\binom{9}{4} \binom{5}{4}$	
	(ii) Number of ways = Only the Brothers separated – Brothers separated but sisters are together	
	= $9! \binom{10}{3} 3! - 2! 8! \binom{9}{3} 3!$	
	– Demonstrated the slotting method. (either slotting of the 3 brothers among the rest or slotting of the 2 sisters among the rest.) – Correct complementary method.	
	= 220631040	
	(bi) Req Prob = $P(A \cup B) - P(A \cap B)$	
	= $P(A) + P(B) - 2P(A \cap B)$	
	= $\frac{11}{20} + \frac{2}{5} - \frac{1}{2}$	
	= $\frac{9}{20}$	
	(ii) $P(B) - P(A \cap B) = \frac{2}{5} - \frac{1}{4} = \frac{3}{20}$	
	(iii)	
		
	$P(A \cap C) = \frac{11}{40}$	
	Largest $a = 1 - P(A \cup B) = 1 - \frac{7}{10} = \frac{3}{10}$	

	As $a + b = \frac{9}{40}$ ,										
	To minimize $(a + b)$ , $b$ is to be as large as possible.										
	Since $b + c = \frac{3}{20}$ , largest $b$ is $\frac{3}{20}$										
	Hence $\min a = \frac{3}{40}$										
	$\frac{3}{40} \leq P(A' \cap B' \cap C) \leq \frac{3}{10}$										
<b>11</b>	In an attempt to reduce the operating costs of an airline company, an analyst collected data on the seat capacity and the total fuel use of the different types of airplanes used for a particular route, as shown in the table below.										
	Seat capacity, $x$ (in hundreds)	4.07	3.84	4	3.31	2.48	2.92	3.1	3.57		
	Total fuel use, $y$ ( $10^3$ tonnes)	140	115	$m$	11	20	25	33	74		
	<b>(a) (i)</b> Given that the equation of the least squares regression line of $y$ on $x$ is $y = 79.695x - 205.86$ , show that the value of $m$ is 110, correct to the nearest whole number.										[2]
	<b>(ii)</b> Give an interpretation, in context, of the gradient of the least squares regression line given in <b>(a)(i)</b> .										[1]
	The analyst suspects that the fuel use for one of the points has been recorded wrongly.										
	<b>(b) (i)</b> Draw a scatter diagram for the data, labelling the axes clearly. On your diagram, circle the point for which the total fuel use has been recorded wrongly and label it as $Q$ .										[2]
	<b>(ii)</b> Explain from your scatter diagram why the relationship between $x$ and $y$ should not be modelled by an equation of the form $y = ax + b$ .										[1]
	For the following parts of this question, you should exclude the point $Q$ for the subsequent calculation.										
	<b>(iii)</b> The analyst is presented with the following two models: (A) $y = ae^x + b$ (B) $y = ax^3 + b$ . Explain clearly which of the two models is the more appropriate model.										[2]
	<b>(iv)</b> Using the more appropriate model from <b>(b)(iii)</b> , estimate the total fuel use when the seating capacity of an airplane is 331. Leave your answer to the nearest whole number.										[2]
	<b>(v)</b> Give two reasons why the estimation in part <b>(b)(iv)</b> is reliable.										[2]
	<b>Solution</b>										
	<b>(a)(i)</b> Given $y = 79.695x - 205.86$ ,										

	$\bar{x} = \frac{4.07 + 3.84 + 4 + 3.31 + 2.48 + 2.92 + 3.1 + 3.57}{8}$ $= 3.41125$	
	$\bar{y} = \frac{140 + 115 + m + 11 + 20 + 25 + 33 + 74}{8}$ $= \frac{418 + m}{8}$	
	Substitute $\bar{x}$ , $\bar{y}$ into the regression line,	
	$\frac{418 + m}{8} = 79.695(3.41125) - 205.86$	
	$m = 109.997$ $m = 110$	
	<b>(ii)</b> It means that the total fuel use increases by $79.695 \times 10^3$ tonnes when the seat capacity increases by 100.	
	<p><b>(b) (i)</b></p>	
	<b>(ii)</b> The scatter diagram in (b)(i), excluding point $Q$ , suggests that as $x$ increases, $y$ increases at an increasing rate so model A is not the most appropriate.	
	<b>(iii)</b> (A): $r = 0.98265$ (B): $r = 0.97787$	
	As $ r $ for model (A) is the closest to 1, therefore, model A is the most appropriate model.	
	<b>(iv)</b> Least squares regression line using model A:	
	$y = 2.6061e^x - 18.429$	
	When $x = 3.31$ , $y = 2.6061e^{3.31} - 18.429$ $= 52.939$ So total amount of fuel used is 52 939 tonnes.	
	<b>(v)</b> Since $r = 0.98265$ is close to 1, which suggests that there is a strong positive linear relationship between $e^x$ and $y$ , and $x = 3.31$ is between 2.48 and 4.07, so interpolation is reliable.	

<b>12</b>	Based on past statistical data of high speed train journey, there is a 8% chance that a passenger with reservation made will not show up. In order to maximise revenue, a high speed train company accepts more reservations than the passenger capacity of its trains.	
	(i) State 2 assumptions needed such that the number of passengers who do not show up for a high speed train journey may be well modelled by a Binomial distribution.	[2]
	A train company operates a high speed train from Burong Lake to Huahin Cove which has a capacity of 280 passengers.	
	(ii) Find the probability that when 300 reservations are accepted, the high speed train journey is overbooked, i.e. there is not enough seats available for the passengers who show up.	[2]
	(iii) Find the maximum number of reservations that should be accepted in order to ensure that the probability of overbooking is less than 1%.	[3]
	The high speed train operates once daily throughout the year and 300 reservations are accepted for each journey.	
	(iv) Find the probability that no high speed train journey is overbooked in a week.	[2]
	(v) Two such journeys from Burong Lake to Huahin Cove with 300 reservations each are examined. If the total number of passengers who turned up for these two journeys is at most 550 passengers, find the probability that one of the journeys is overbooked by at most 2 passengers.	[3]
	<b>Solution</b>	
	(i) The event that a passenger shows up or fails to show up is independent of the other passengers.  The probability that a passenger does not show up is a constant at 0.08 for every passenger.	
	(ii) Let $X$ denote the number of passengers with reservations and show up out of 300 passengers. $X \sim B(300, 0.92)$	
	$P(X > 280) = 1 - P(X \leq 280) = 0.16948$ $= 0.169$ (3 s.f.)	
	(iii) Let $Y$ denote the number of passengers with reservations and show up out of $n$ passengers. $Y \sim B(n, 0.92)$ $P(Y > 280) < 0.01$	
	$1 - P(Y \leq 280) < 0.01$ $P(Y \leq 280) > 0.99$	
	Using GC, When $n = 292$ , $P(Y \leq 280) = 0.9973 > 0.99$ When $n = 293$ , $P(Y \leq 280) = 0.9944 > 0.99$ When $n = 294$ , $P(Y \leq 280) = 0.9891 < 0.99$	
	Hence the maximum reservations that should be accepted is 293.	
	(iv) Let $W$ denote the number of train journeys which is overbooked, out of 7. $W \sim B(7, 0.16948)$	

	$P(W = 0) = 0.27255 = 0.273$ (3 s.f.)	
(v)	Let $X$ denote the number of passengers with reservations and show up out of 300 passengers. $X \sim B(300, 0.92)$ Let $V$ denote the number of passengers with reservations and show up out of 600 passengers. $V \sim B(600, 0.92)$	
	$P(281 \leq \text{one train journey} \leq 282   V \leq 550)$	
	$= \frac{2[P(X_1 = 281)P(X_2 \leq 269) + P(X_1 = 282)P(X_2 \leq 268)]}{P(V \leq 550)}$	
	$= \frac{2 \times 0.0068344}{0.40297}$	
	$= 0.0339199$	
	$= 0.0339$ (3 s.f.)	

**THE END**

**[TURN OVER]**