

CANDIDATE'S NAME: _____

CTG: _____

YISHUN JUNIOR COLLEGE
2018 JC2 PRELIMINARY EXAMINATION

CHEMISTRY
HIGHER 2

9729/01

Paper 1 Multiple Choice

THURSDAY 13 SEPTEMBER 2018
1400hrs – 1500hrs
(1 hour)

Additional Materials: Optical Mark Sheet (OMS)
Data Booklet



READ THESE INSTRUCTIONS FIRST

Write in soft pencil.
Do not use staples, paper clips, highlighters, glue or correction fluid.

Write your name, CTG, and NRIC / FIN number on the Optical Mark Sheet (OMS), and shade the corresponding boxes for your NRIC / FIN number.

There are **thirty** questions on this paper. Answer **all** questions. For each question there are four possible answers **A, B, C** and **D**.
Choose the **one** you consider correct and record your choice in **soft pencil** on the separate Answer Sheet.

Read the instructions on the Answer Sheet very carefully.

Each correct answer will score one mark. A mark will not be deducted for a wrong answer.
Any rough working should be done in this booklet.

The use of an approved scientific calculator is expected, where appropriate.

2

- 1 10 cm³ of a pure hydrocarbon was completely burned in 80 cm³ of excess oxygen at 425 K. After cooling to room temperature, the volume of the gaseous mixture was found to be 55 cm³. A reduction of 40 cm³ was observed when the residual gases were passed through calcium hydroxide. All gas volumes were measured at the same temperature and pressure.

What is the formula of the hydrocarbon?

- A C₄H₁₀ B C₄H₈ C C₂H₆ D C₂H₄

- 2 Sodium hydrogen carbonate, NaHCO₃, can be prepared from sodium sulfate by a three-step process as shown.

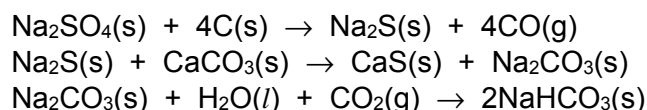

Assuming a yield of 90% in each step, determine the mass of sodium hydrogen carbonate, to the nearest kg, that could be obtained from 100 kg of sodium sulfate.

- A 146 kg B 122 kg C 86 kg D 43 kg

- 3 Ions of the two common isotopes of nickel are shown below.



Which statements about these ions are correct?

- 1 ⁵⁸Ni²⁺ ion has a greater number of nucleons in its nucleus than the ⁶⁰Ni²⁺ ion.
- 2 Both ions have the same number of protons.
- 3 Both ions have more neutrons than electrons.
- 4 A beam of ⁵⁸Ni²⁺ ion is deflected to a larger extent than that of ⁶⁰Ni²⁺ ion in an electric field.

- A 1, 2, 3 and 4
B 1, 2 and 3
C 2 and 3
D 2, 3 and 4

- 4 Two bulbs **R** and **S** are connected to a 9 dm^3 vacuum chamber as shown.

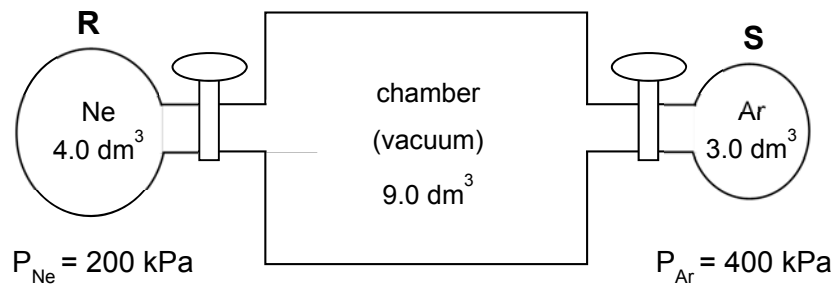

What will be the total pressure in the vessel when the valves are opened at constant temperature?

- A** 600 kPa
B 286 kPa
C 222 kPa
D 125 kPa
- 5 Which graph incorrectly describes the behaviour of a fixed mass of an ideal gas?

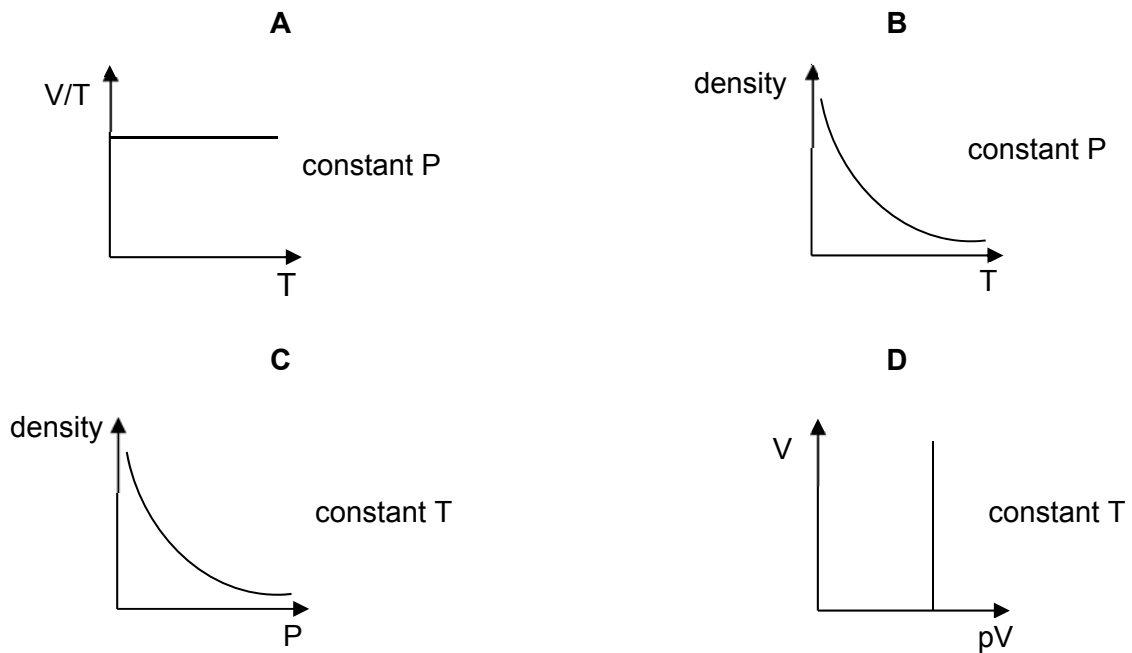

- 6 Allotropes of carbon include diamond, graphite and fullerene. A spherical fullerene, known as buckminsterfullerene, has the formula C_{60} with the following structure.

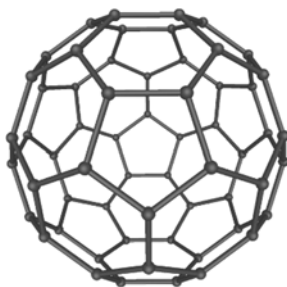

Which statement is correct?

- A All the bond angles in buckminsterfullerene are 120° .
 - B There are delocalised electrons within buckminsterfullerene.
 - C Buckminsterfullerene sublimes at a higher temperature than graphite.
 - D On complete combustion, buckminsterfullerene forms carbon dioxide and water.
- 7 The enthalpy change of solution of magnesium fluoride is found to be negative while that of barium fluoride is positive.

Which statement best explains this observation?

- A Magnesium fluoride is soluble in water, but barium fluoride is insoluble.
- B The hydration energy of the barium ion is bigger in magnitude than that of the magnesium ion.
- C The lattice energy of barium fluoride is bigger in magnitude than that of magnesium fluoride.
- D The lattice energy of barium fluoride is bigger in magnitude than the sum of the hydration energies of the barium and fluoride ions.

- 8 Which sketch shows the incorrect trend for the stated property for elements in the third period of the Periodic Table?

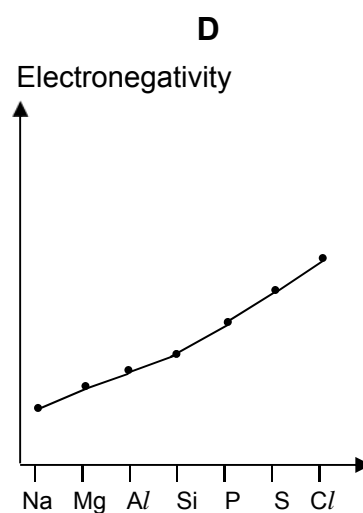
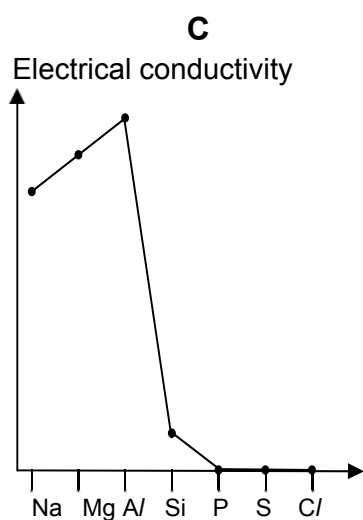
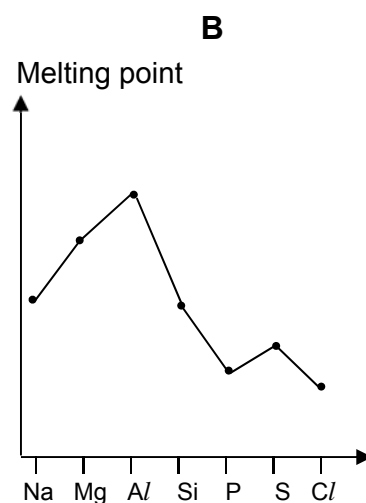
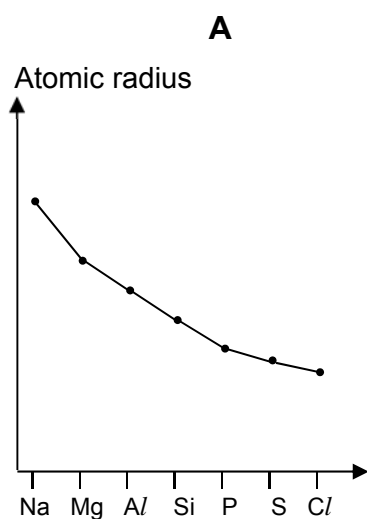

- 9 The table shows the results of experiments in which the halogens X_2 , Y_2 and Z_2 are added to aqueous solutions containing X^- , Y^- , and Z^- ions.

	$X^-(aq)$	$Y^-(aq)$	$Z^-(aq)$
X_2	no reaction	no reaction	no reaction
Y_2	X_2 formed	no reaction	Z_2 formed
Z_2	X_2 formed	no reaction	no reaction

Which row shows the correct order of the reducing strength of the halide ions?

- | | strongest | | weakest |
|----------|-----------|-------|---------|
| A | X^- | Z^- | Y^- |
| B | Y^- | Z^- | X^- |
| C | Z^- | Y^- | X^- |
| D | X^- | Y^- | Z^- |

10 The diagram below shows the positions of four elements **W**, **X**, **Y** and **Z** in periods 2 and 3.

	W		
X		Y	Z

Element **Y** has the following successive ionisation energies(IE).

IE /kJ mol ⁻¹	1011	1907	2914	4963	6273	21268	29872
--------------------------	------	------	------	------	------	-------	-------

Which statement about elements **W**, **X**, **Y** and **Z** and their compounds is incorrect?

- A** The oxide of **X** is insoluble in water.
- B** The first ionisation energy of **Z** is lower than that of **Y**.
- C** When HCl(aq) is added to a sample containing oxide of **X**, the solid dissolves.
- D** **W**, **Y** and **Z** form chlorides which will react with water to produce acidic solutions.

11 Use of Data Booklet is relevant to this question.

The lattice energy of beryllium nitride can be determined via the following energy cycle.

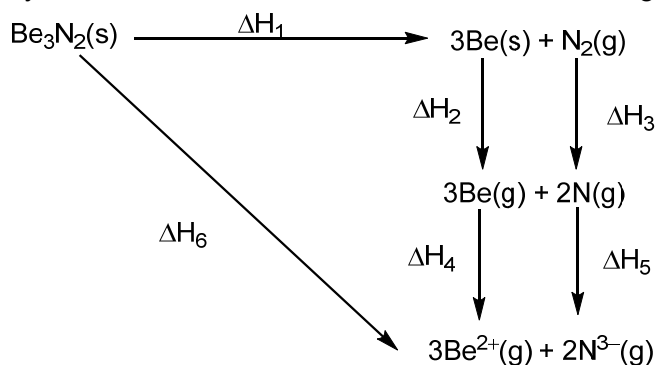

Enthalpy Change	$\Delta H / \text{kJ mol}^{-1}$
ΔH_2	+324
ΔH_5	+1404
ΔH_6	+11300

Which statements are correct?

- 1 The enthalpy change of formation, ΔH_f , of Be_3N_2 is $+648 \text{ kJ mol}^{-1}$.
 - 2 ΔH_3 is always endothermic.
 - 3 The average energy of the electrostatic forces of attraction present in Be_3N_2 is $11300 \text{ kJ mol}^{-1}$.
- A** 1 only
 - B** 2 and 3 only
 - C** 1 and 2 only
 - D** 1, 2 and 3

12 In which processes will ΔS be negative?

- 1 The burning of sulfur in oxygen to produce sulfur dioxide gas.
- 2 The dissolution of solute in solvent.
- 3 The synthesis of an ionic compound from its constituent gaseous ions.

- A** 3 only
B 1 and 3 only
C 1 and 2 only
D 1, 2 and 3

13 A bomb calorimeter contains 225 dm^3 of hydrazine, N_2H_4 as fuel. After combustion, the temperature change in the calorimeter was found to be $w^\circ\text{C}$.

The heat capacity of the calorimeter is $z \text{ kJ K}^{-1}$. The density of liquid hydrazine is 1.02 g cm^{-3} and its enthalpy change of combustion, ΔH_c , is $-622.2 \text{ kJ mol}^{-1}$

Which of the following represents the percentage efficiency of the bomb calorimeter?

A Percentage efficiency = $\frac{225 \times 1000 \times 1.02 \times z \times w}{622.2} \times 100\%$

B Percentage efficiency = $\frac{225 \times 1000 \times 1.02 \times z \times (w + 273)}{622.2} \times 100\%$

C Percentage efficiency = $\frac{(w + 273) \times z}{\frac{225 \times 1000 \times 1.02}{\text{Molar mass (N}_2\text{H}_4)}} \times 622.2 \times 100\%$

D Percentage efficiency = $\frac{w \times z}{\frac{225 \times 1000 \times 1.02}{\text{Molar mass (N}_2\text{H}_4)}} \times 622.2 \times 100\%$

- 14 Consider the following reaction: $\text{X(aq)} + \text{Y(g)} \rightleftharpoons \text{Z(g)}$ $\Delta H < 0$
The graph shows the number of moles of gases in a reaction mixture as it changes with time.

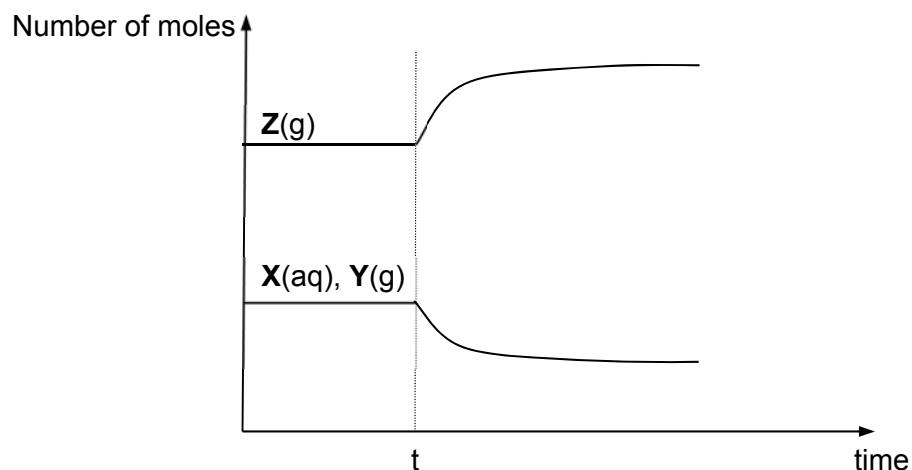

The reaction mixture is initially at equilibrium until time, t , when a disturbance is introduced to the system. Which of the disturbances at time, t , can account for the observed change in the graph above?

- 1 An increase in pressure
- 2 Addition of water into the aqueous solution
- 3 Increase in temperature

- A** 1 only
B 2 only
C 1, 2 and 3
D None of the above

- 15 Given that the K_p for the following equilibrium is 64,

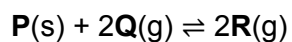

What is the mole ratio of **Q** : **R** at equilibrium?

- A** 1 : 1
B 1 : 8
C 8 : 1
D 64 : 1

- 16 The graph below shows how the pH changes when 0.1 mol dm^{-3} solution of **Y**(aq) was gradually added to 10 cm^3 of 0.1 mol dm^{-3} solution of **X**(aq).

What could **X** and **Y** be?

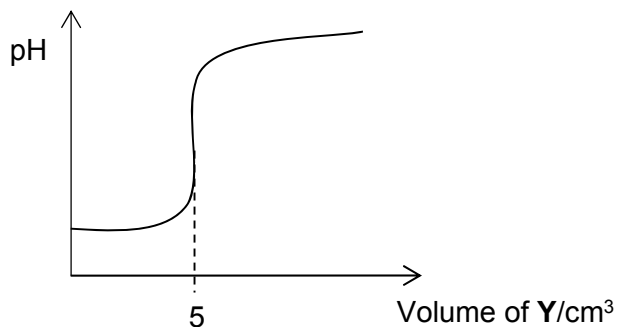

	X	Y
A	NaOH	HCl
B	HCl	NaOH + KOH
C	HCl	Na ₂ CO ₃
D	HCl	NaHCO ₃

- 17 The diagram below represents the Boltzmann distribution of molecular energies at a given temperature.

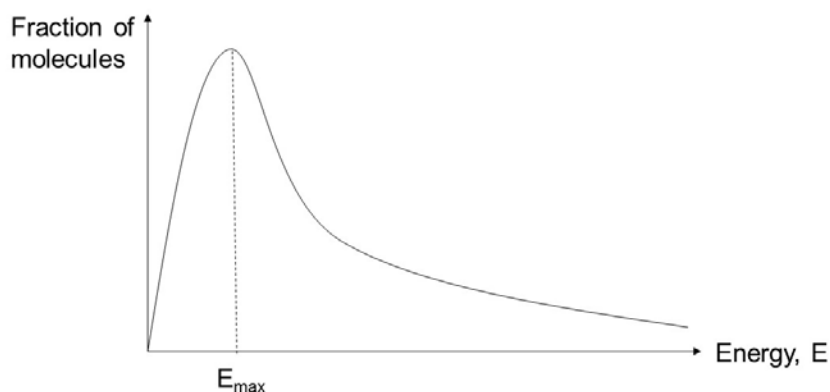

With an increase in temperature, which statements are correct?

- 1 At all energies, the proportion of molecules increases.
- 2 The peak of the graph decreases.
- 3 The value of the rate constant, k , increases.

- A** 1 only
B 1 and 3 only
C 2 and 3 only
D 1, 2 and 3

18 Use of Data Booklet is relevant to this question.

Solid compound **J** has the following structure. It undergoes complete combustion in air to produce carbon dioxide, water and nitrogen dioxide only.

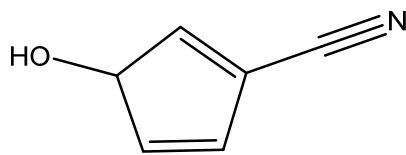

Compound **J**

Which statement about compound **J** is correct?

- A** On complete combustion, 0.10 g of compound **J** produces 0.230 g of CO_2 .
- B** On complete combustion, 0.10 g of compound **J** produces 22.4 cm^3 of NO_2 measured under room conditions.
- C** 0.10 g of compound **J** reacts with excess bromine in organic solvent to produce 0.380 g of product.
- D** 0.10 g of compound **J** reacts with hydrogen gas and platinum catalyst to produce 0.100 g of product.

19 Which reaction will produce a mixture which is optically inactive?

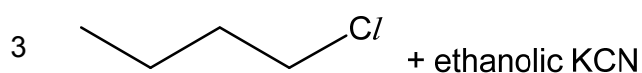
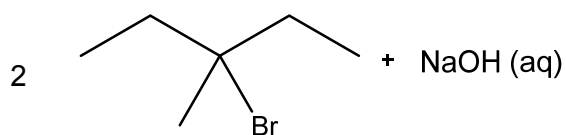
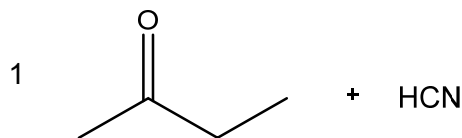

- A** 1, 2 and 3
- B** 1 and 2 only
- C** 1 only
- D** 2 and 3 only

20 How many constitutional isomers are possible for a substituted benzene, C_8H_{10} ?

- A 3
- B 4
- C 5
- D 6

21 How many chiral carbons are formed in the major product of the following reaction?

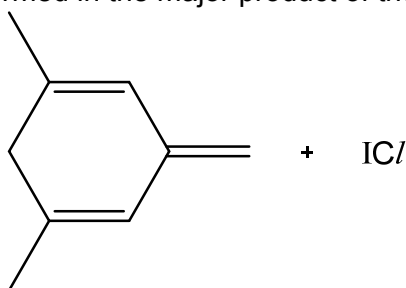

- A 2
- B 3
- C 4
- D 5

22 Which statement best explains why benzene undergoes substitution reaction while ethene undergoes addition reaction?

- A Benzene provides steric hindrance to repel reactive species.
- B The $C=C$ bonds in benzene are shorter and stronger than the $C=C$ bonds in ethene.
- C There is delocalisation of π electrons in benzene which is absent in ethene.
- D Benzene contains more $C=C$ bonds than ethene, hence it is more electron rich.

23 Benzoic acid can be obtained using either a one-step or two-step synthesis.

Which of the following cannot be used as the starting material?

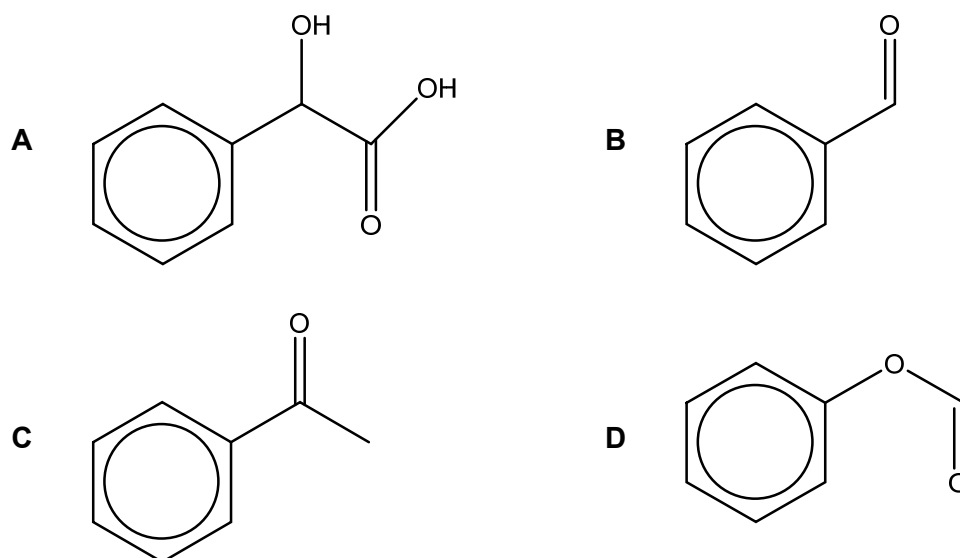

24 A catalytic converter is a device used to reduce the toxicity of emissions from an internal combustion engine. It works by using a catalyst (platinum, palladium or rhodium) to stimulate a chemical reaction in which toxic by-products of combustion are converted to less toxic substances.

Identify the chemical reactions occurring.

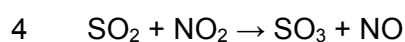
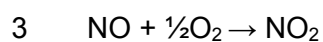
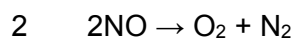
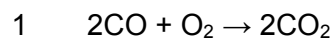

A 1 and 2 only

B 2 and 3 only

C 1, 2 and 3 only

D 3 and 4 only

25 The following compound is heated with dilute sodium hydroxide.

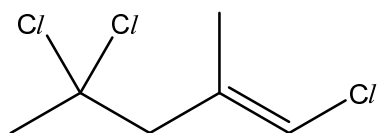

Which of the following product is obtained?

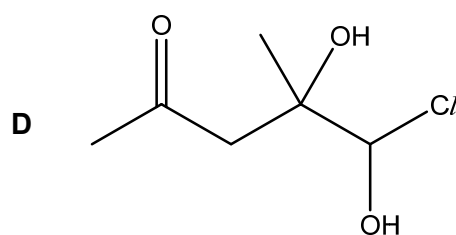
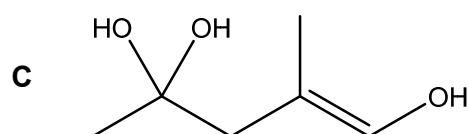
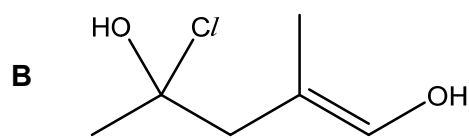
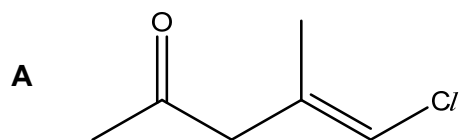

26 Consider the following four compounds.

- 1 propanol
- 2 phenol
- 3 propanoic acid
- 4 water

What is the relative order of **decreasing** acidity of these compounds?

- A** 1 2 4 3
- B** 3 2 1 4
- C** 3 2 4 1
- D** 1 4 2 3

- 27 Compound **X** decolourises aqueous bromine. Compound **X** reacts with hot acidified potassium manganate(VII) to form compound **Y**. The following table shows some tests and observations carried out on compound **Y**.

compound	Tests	Observations
Y	Na_2CO_3	Effervescence observed. Gas evolved forms white precipitate with limewater
	2,4-dinitrophenylhydrazine	Orange precipitate

What could compound **X** be?

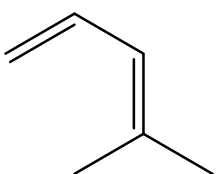
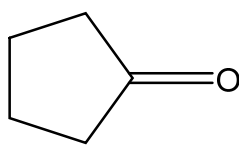
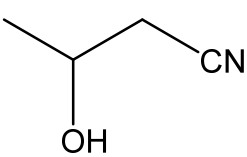
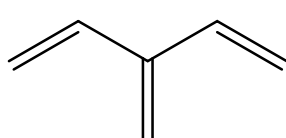
- A** 
- B** 
- C** 
- D** 

- 28 Glyphosate is a herbicide used to kill weeds.

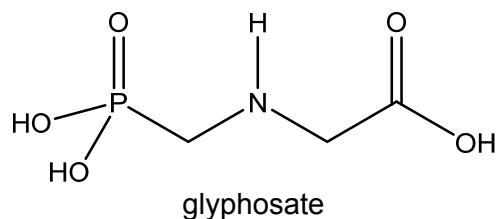

Glyphosate has pK_a values of 0.8, 2.3, 6.0 and 11.0.

What is the structure of the major species in a solution of glyphosate at pH 7?

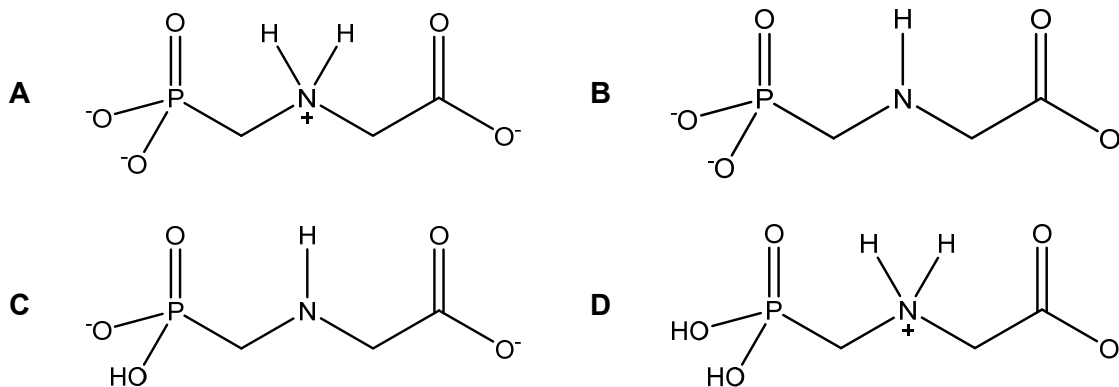

- 29 *Use of Data Booklet is relevant to this question.*

Which of the following reactions of transition metals is incorrect?

- A** Addition of $H_2O_2(aq)$ to acidified $K_2Cr_2O_7(aq)$ produces a green solution.
- B** V^{3+} is a suitable catalyst for the reaction: $2I^- + S_2O_8^{2-} \rightarrow I_2 + 2SO_4^{2-}$.
- C** Addition of concentrated HCl to $CuSO_4(aq)$ produces a yellow solution.
- D** Addition of $Na_2CO_3(aq)$ to $Cr^{3+}(aq)$ produces a gas that gives a white precipitate when bubbled through limewater.

- 30 The following energy level diagram represents the dissolving of anhydrous magnesium chloride in a large volume of water.

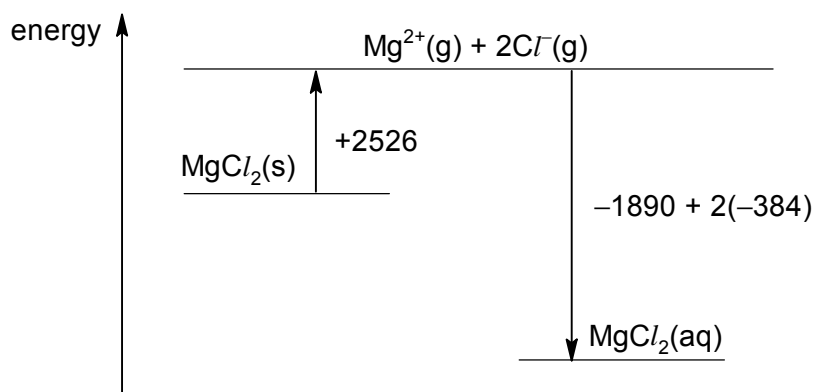

Which statements about the process are correct?

- 1 The lattice energy of magnesium chloride is $-2526 \text{ kJ mol}^{-1}$.
 - 2 The enthalpy change of hydration of the chloride ion is -384 kJ mol^{-1} .
 - 3 The enthalpy change of solution of anhydrous magnesium chloride is -132 kJ mol^{-1} .
 - 4 $\text{Mg}^{2+}(\text{g})$ and $\text{Cl}^{-}(\text{g})$ are less thermally stable than $\text{MgCl}_2(\text{aq})$.
- A** 1, 2, 3 and 4
B 1, 2 and 3 only
C 2 and 3 only
D 2 and 4 only

Paper 1 Worked Solutions

1	A	2	C	3	D	4	D	5	C
6	B	7	D	8	B	9	A	10	D
11	B	12	A	13	D	14	D	15	B
16	C	17	C	18	B	19	A	20	B
21	C	22	C	23	D	24	A	25	A
26	C	27	D	28	A	29	B	30	A

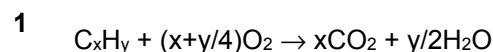

$$V_{O_2(excess)} + V_{CO_2} = 55$$

$$\text{Since } V_{CO_2} = 40 \text{ cm}^3, V_{O_2(excess)} = 55 - 40 = 15 \text{ cm}^3$$

$$V_{O_2(reacted)} = 80 - 15 = 65 \text{ cm}^3$$

$$\text{Mole ratio of } C_xH_y : CO_2 = 1:x = 10:40 \Rightarrow x = 4$$

$$\text{Mole ratio of } C_xH_y : O_2 = 1:(x+y/4) = 10:65 \Rightarrow y = 10$$

Formula of the hydrocarbon is C_4H_{10} .

Ans: A

- 2 Given 90% in each of the three steps,
 1 mol of $Na_2SO_4(s)$ yields 0.9 mol of $Na_2S(s)$.
 In turn, 0.9 mol of $Na_2S(s)$ yields 0.81 mol of $Na_2CO_3(s)$.
 In turn, 0.81 mol of $Na_2CO_3(s)$ yields 1.458 mol of $NaHCO_3(s)$.

$$\Rightarrow \text{Mole ratio of } Na_2SO_4(s) : NaHCO_3(s) = 1:1.458$$

$$\text{Mass of } NaHCO_3(s) = \left(\frac{1000000}{142} \times 1.458 \right) \times 84.0 = 86248 \text{ g} = 86.2 \text{ kg}$$

Ans: C

- 3 Option 1 is incorrect. $^{58}Ni^{2+}$ ion has 58 nucleons while $^{60}Ni^{2+}$ ion has 60 nucleons.
 Option 2 is correct. Both Ni isotopes have 28 protons.
 Option 3 is correct. $^{58}Ni^{2+}$ ion has 30 neutrons and 26 electrons while $^{60}Ni^{2+}$ ion has 32 neutrons and 26 electrons.
 Option 4 is correct. Angle of deflection is directly proportional to $\frac{\text{charge}}{\text{mass}}$ ratio. Since $^{58}Ni^{2+}$ ion has a smaller mass than that of $^{60}Ni^{2+}$ ion, it has a

bigger angle of deflection.

Ans: D

4 $V_1P_1 + V_2P_2 = V_T P_T$
 $(4)(200) + (3)(400) = P_T(16)$
 $P_T = 125 \text{ kPa}$

Ans: D

- 5 Option C is incorrect.

$$pV = nRT$$

$$p = \rho \cdot \frac{RT}{Mr}$$

$$\rho = p \cdot \frac{Mr}{RT}$$

A plot of density against pressure, at constant temperature, would give a linear graph of a positive gradient.

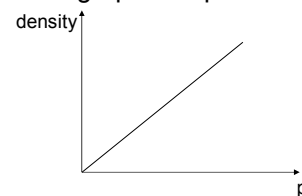

Ans: C

- 6 Option A is incorrect. From the given diagram, the presence of hexagons and pentagons imply different bond angles within buckminsterfullerene.
 Option B is correct. From the given diagram, all the carbon in buckminsterfullerene is sp^2 hybridised hence the 4th electron of each carbon is delocalised within the sphere.
 Option C is incorrect. The sublimation point of buckminsterfullerene should be lower than that of graphite, as it has a simple molecular structure with instantaneous dipole-induced dipole interactions between molecules whereas graphite has a giant molecular structure with strong covalent bonds between atoms.

Option D is incorrect. The absence of hydrogen in buckminsterfullerene implies the absence of water during combustion.

Ans: B

- 7 Option A is incorrect. Compounds can dissolve endothermically hence it is possible that barium fluoride can dissolve in water.
 Option B is incorrect. Ba^{2+} is bigger in size than Mg^{2+} hence Ba^{2+} has a lower charge density and therefore less polarising. The hydration energy of Ba^{2+} will be smaller in magnitude than that of Mg^{2+} .
 Option C is incorrect. LE depends on the charge and size of the ions. Since Ba^{2+} is bigger in size than Mg^{2+} , LE of BaF_2 will be smaller in magnitude than MgF_2 .
 Option D is correct. Both ΔH_{LE} and $\Delta H_{\text{hydration}}$ are negative and $\Delta H_{\text{solution}} = \Sigma\Delta H_{\text{hydration}} - \Delta H_{\text{LE}}$. For $\Delta H_{\text{solution}}(\text{BaF}_2)$ to be negative, ΔH_{LE} must be bigger in magnitude than $\Sigma\Delta H_{\text{hydration}}$.

Ans: D

- 8 Option A is correct: Atomic radius decreases across the period. Nuclear charge increases as number of protons increases across the period. Electrons are added to the same valence shell hence shielding effect remains almost constant. Effective nuclear charge increases and thus, the valence electrons are more strongly attracted to the nucleus.
 Option B is incorrect: Melting point trend should be as shown instead, where the melting point of Si is the highest.

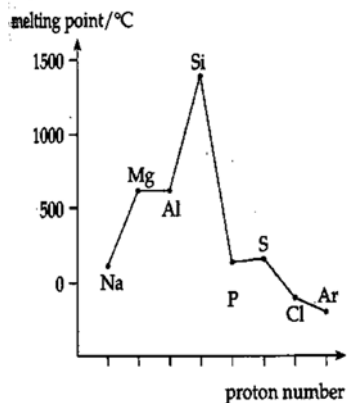

Option C is correct: The ability to conduct electricity depends on the presence of mobile charge carriers. Electrical conductivity increases

from Na to Al due to the increase in number of valence electrons available in "sea" of delocalised electrons. Si is a semiconductor, while P, S and Cl are non-conductors.

Option D is correct: Electronegativity increases across the period. Nuclear charge increases. Shielding effect remains relatively constant as the number of inner shell electrons remains the same. There is a larger effective nuclear charge, and thus a stronger net attraction for a bond pair of electrons in a covalent bond.

Ans: B

- 9 A halogen that is a stronger oxidising agent can oxidise a halide below it in the group. From the results of the table, it can be deduced that the oxidising power of the halogens: $\text{Y}_2 > \text{Z}_2 > \text{X}_2$
 Thus the reducing power of the halide ions is: $\text{X}^- > \text{Z}^- > \text{Y}^-$

Ans: A

- 10 From the successive IE, there is a big jump between the 5th IE and 6th IE. Hence, the 6th electron must have been removed from an inner principal quantum shell. Hence there are 5 electrons in the outermost shell and element Y is from Group 15.
 It can be inferred therefore that X: Group 13; W: Group 14; Z: Group 16

Option A is correct: The oxide of X (i.e. Al_2O_3) is insoluble in water. The small and highly charged Al^{3+} ion results in highly exothermic lattice energy. Hence, the energy that is released during hydration cannot compensate for the larger amount of energy that is required to overcome the strong ionic bonds in the giant lattice.

Option B is correct. The first IE of Z (i.e. sulfur) is lower than that of Y (i.e. phosphorus). This is one of the two exceptions in the 1st IE trends - for Z, electron is removed from a paired electron occupying the same 3p orbital. Thus, the electron experiences inter-electronic repulsion and lesser energy is required to remove it.

Option C is correct. Oxide of X (i.e. Al_2O_3) is amphoteric, and will react with both acids and bases. $\text{Al}_2\text{O}_3(\text{s}) + 6\text{HCl}(\text{aq}) \rightarrow 2\text{AlCl}_3(\text{aq}) + 3\text{H}_2\text{O}(\text{l})$

Option D is incorrect. The chloride of W (i.e. CCl_4) does not undergo hydrolysis in water as it does not have energetically accessible vacant 3d orbitals (unlike the chlorides of Y and Z) which can accommodate lone pair of electrons from oxygen atoms of water during hydrolysis.

Ans: D

- 11 Option 1 is incorrect.

$-\Delta H_1$ = The enthalpy change of formation, ΔH_f , of Be_3N_2

Since $3 \text{Be(s)} + 3 \text{N}_2(\text{g}) \rightarrow \text{Be}_3\text{N}_2$

$$\begin{aligned} -\Delta H_1 &= \Delta H_2 + \Delta H_3 + \Delta H_4 + \Delta H_5 - \Delta H_6 \\ &= +324 + 944 (\text{BE of N}\equiv\text{N}) + 3(900+1760) + 1404 - 11300 \\ &= -648 \text{ kJ mol}^{-1} \end{aligned}$$

Option 2 is correct. Enthalpy change of atomisation is always endothermic. In this question, energy is absorbed to break $\text{N}\equiv\text{N}$ to produce 2 N atoms.

Option 3 is correct. ΔH_6 represents $-|\text{Lattice Energy of Be}_3\text{N}_2|$. Lattice energy is a measure of the ionic bond strength.

Ans: B

- 12 Option 1 is incorrect. $\text{S(s)} + \text{O}_2(\text{g}) \rightarrow \text{SO}_2(\text{g})$

There is no change in the number of moles of gaseous reactants and products.

Option 2 is incorrect. When a solute dissolves in solvent, there is an increase in the disorderliness of the system.

Option 3 is correct. Formation of a solid ionic compound from its constituent gaseous ions results in a decrease in disorderliness of the system as the ions are now held in fixed positions.

Ans: A

- 13 Percentage efficiency

$$\begin{aligned} &= \frac{\text{heat transferred to calorimeter}}{\text{heat released due to the combustion of hydrazine}} \times 100\% \\ &= \frac{\Delta T \times C}{\text{amount of hydrazine used} \times \text{enthalpy change of combustion}} \times 100\% \\ &= \frac{W \times Z}{\frac{225 \times 1000 \times 1.02}{\text{Molar mass (N}_2\text{H}_4)}} \times 622.2 \times 100\% \end{aligned}$$

Ans: D

14. Option 1 is incorrect. An increase in pressure will not result in a shift in position of equilibrium since the number of moles of gaseous reactants = number of moles of gaseous products.

Option 2 is incorrect. Addition of water results in a decrease in concentration of **X**. Hence, position of equilibrium will shift to the left in order to increase the concentration of **X**. Hence, concentration of **Z** should decrease.

Option 3 is incorrect. An increase in temperature will result in the position of equilibrium shifting left in order to absorb heat energy since the backward reaction is endothermic. Hence, concentration of **Z** should decrease.

Answer: D

- 15 Since $P_Q = \frac{n_Q}{n_T} \times P_T$ and $P_R = \frac{n_R}{n_T} \times P_T$

$$K_p = \frac{(P_R)^2}{(P_Q)^2} = \frac{(n_R)^2}{(n_Q)^2} = 64$$

$$\frac{n_R}{n_Q} = 8$$

$$n_Q : n_R = 1 : 8$$

Ans: B

- 16 Option A is incorrect.

From the graph (increasing pH as volume of **Y** added increases), it can be inferred that a base (**Y**) was added to an acid (**X**). **Y** cannot be HCl . Option B is incorrect. Even though **Y** contains 2 strong bases, the total $[\text{OH}^-]$ is still 0.1 mol dm^{-3} , hence 10 cm^3 of **Y** is needed to neutralise **X**.

Option C is correct. Na_2CO_3 is dibasic. A simple balanced chemical equation (carbonates react with acids to give salt, water and carbon dioxide) will prove that $\text{Na}_2\text{CO}_3 : \text{HCl}$ is 2 : 1 and thus only 5 cm^3 of Na_2CO_3 is needed to react with HCl .

Option D is incorrect. NaHCO_3 is monobasic and 10 cm^3 of NaHCO_3 is required to neutralise HCl .

Ans: C

- 17 Option 1 is incorrect. When temperature increases, the curve is displaced right and the peak is lowered as the total number of molecules remains constant. Proportion of molecules does not increase at all energies.

Option 2 is correct. When temperature increases, the curve is displaced right and peak of graph is lowered as the total number of molecules

remains constant.

Option 3 is correct. When temperature is increased, the value of rate constant k increases.

Ans: C

18

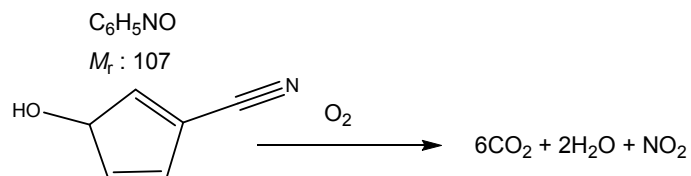

A: Mass of CO_2 formed : $6 \times 9.3458 \times 10^{-4} \times 44 = 0.247 \text{ g}$

B: Volume of NO_2 formed : $9.3458 \times 10^{-4} \times 24000 = 22.4 \text{ cm}^3$

C:

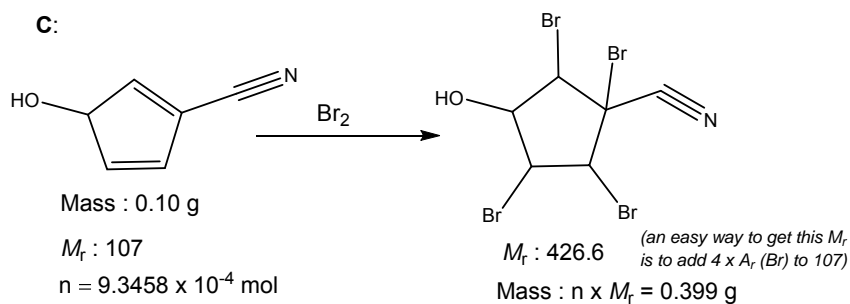

D:

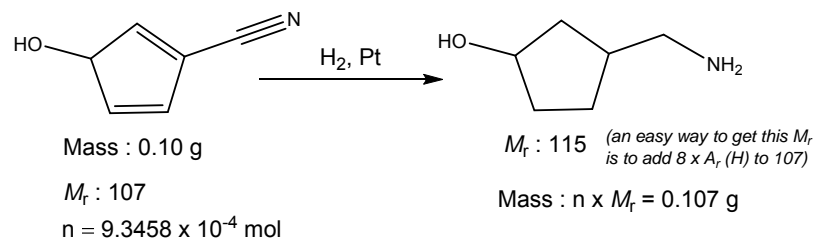

Ans: B

- 19 Option 1: CN^- can approach the planar carbonyl carbon from top and bottom with equal probability to give enantiomers (with chiral carbon).
Option 2: Even though a tertiary carbocation is formed as intermediate

via the S_N1 mechanism, the final product does not have a chiral carbon, hence no enantiomers are formed.

Option 3: S_N2 mechanism has occurred as the reactant is a primary halogenoalkane. The product formed does not have a chiral centre, thus it is optically inactive.

Ans: A

20

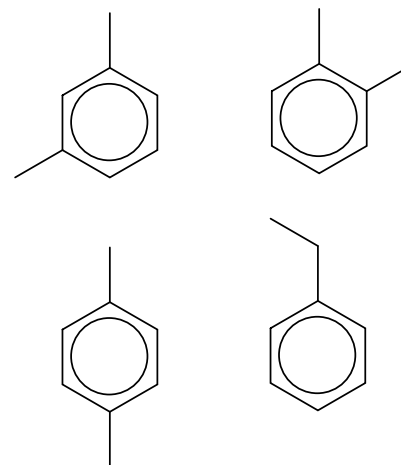

Ans: B

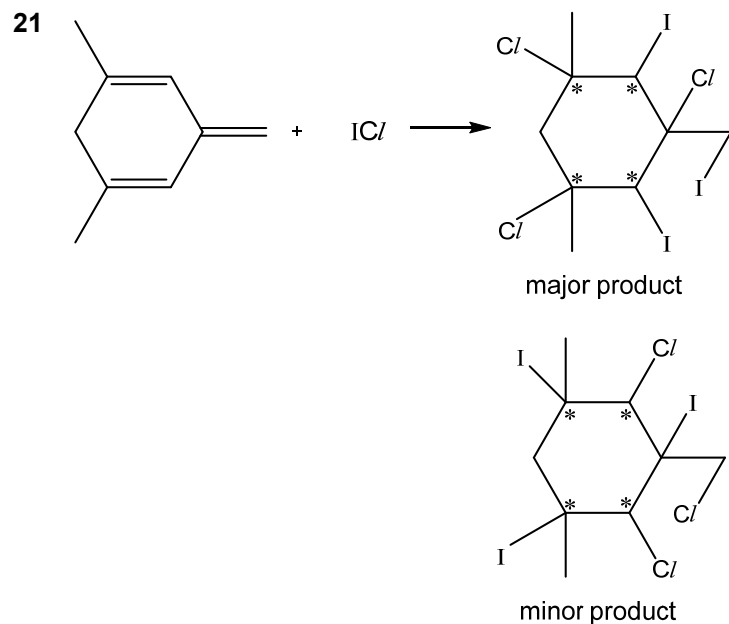

Applying Markovnikov's rule, there are 4 chiral carbons in the major product.

Ans: C

- 22 Benzene prefers to undergo substitution reactions rather than addition reactions due to delocalisation of π -electrons, which leads to resonance stability. Addition reaction destroys this stability. Options A, B and D are true but does not explain why benzene undergoes substitution instead of addition.

Ans: C

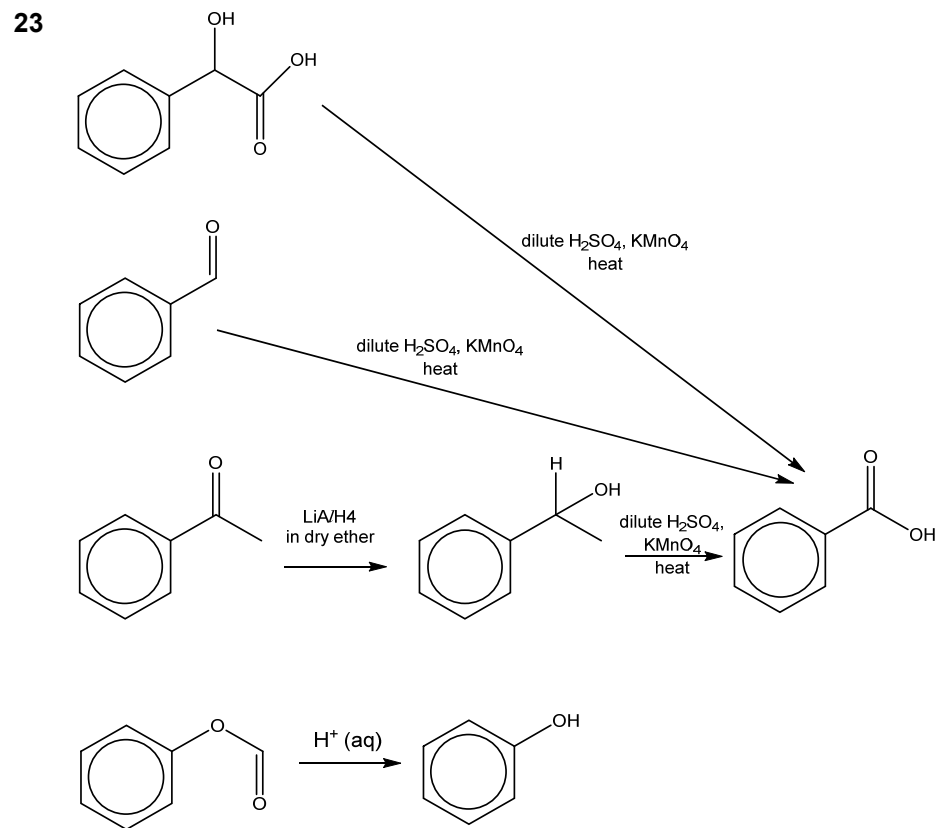

Ans: D

- 24 The following reactions occur:
- Reduction of nitrogen oxides to nitrogen and oxygen with rhodium catalyst: $2\text{NO}_x \rightarrow x\text{O}_2 + \text{N}_2$
 - Oxidation of carbon monoxide to carbon dioxide with platinum and palladium catalyst: $2\text{CO} + \text{O}_2 \rightarrow 2\text{CO}_2$
 - Oxidation of unburnt hydrocarbons to carbon dioxide and water with platinum and palladium catalyst.

Ans: A

25 Ease of nucleophilic substitution with water:

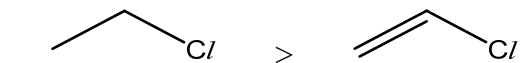

reacts after heating with NaOH

little to no reaction after prolonged heating with NaOH

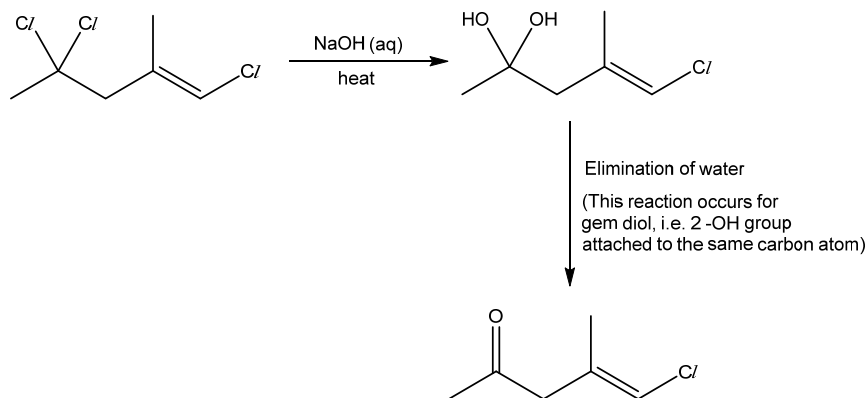

Ans: A

26 To discuss the strength of the acids, **compare** the **stability** of the **conjugate base** of the acids.

e.g.

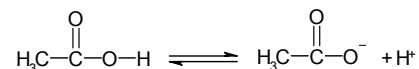

When the conjugate base is more stable, the acid has a greater tendency to dissociate to form the conjugate base and H^+ ions

- The forward reaction occurs to a greater extent
- The equilibrium position lies more to the right.

propanol	phenol	propanoic acid
$\text{ROH} + \text{H}_2\text{O} \rightleftharpoons \text{RO}^- + \text{H}_3\text{O}^+$	$\text{C}_6\text{H}_5\text{OH} + \text{H}_2\text{O} \rightleftharpoons \text{C}_6\text{H}_5\text{O}^- + \text{H}_3\text{O}^+$	$\text{RCOOH} + \text{H}_2\text{O} \rightleftharpoons \text{RCOO}^- + \text{H}_3\text{O}^+$
Alkyl groups are electron donating. Hence negative charge on the oxygen atom in RO^- is intensified compared to OH^- . RO^- is destabilised and hence alcohols are weaker acids than water.	Lone pair of electrons on the oxygen atom delocalised into the benzene ring. The negative charge on the oxygen atom in $\text{C}_6\text{H}_5\text{O}^-$ is delocalised into the ring. This dispersion of charge stabilises $\text{C}_6\text{H}_5\text{O}^-$, hence phenol is more acidic than water.	The negative charge on the oxygen atom in RCOO^- is delocalised between the 2 electronegative oxygen atoms and it is resonance stabilised. Hence carboxylic acids are more acidic than phenol.

Ans: C

27

Information	Deduction
X , is found to decolourise aqueous bromine.	electrophilic addition \Rightarrow Presence of alkene
X reacts with hot acidified potassium manganate(VII) to form compound Y .	Oxidative cleavage of alkene
Y reacts with Na_2CO_3 .	Neutralisation \Rightarrow presence of carboxylic acid
Y reacts with 2,4-dinitrophenylhydrazine.	Condensation \Rightarrow Presence of ketone (oxidative cleavage of alkene gives either carbon dioxide gas, carboxylic acid or ketone only)
Compound X	
Compound Y	

Ans: D

- 28 Both phosphonic acid and carboxylic acid moieties can be ionised and the amine group can be protonated and the substance exists as a series of zwitterions.

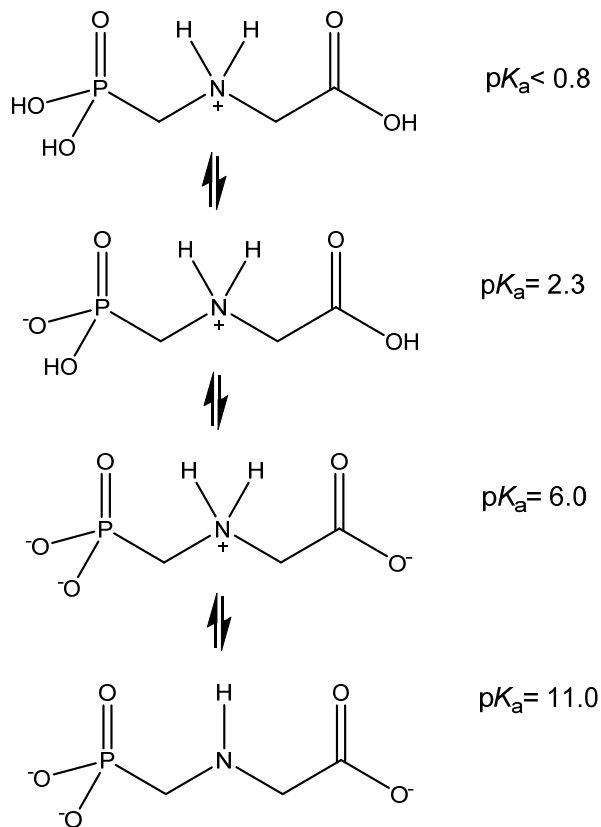

Ans: A

- 29 Option A is correct: addition of $\text{H}_2\text{O}_2(\text{aq})$ to acidified $\text{K}_2\text{Cr}_2\text{O}_7(\text{aq})$ produces a green solution of Cr^{3+} .

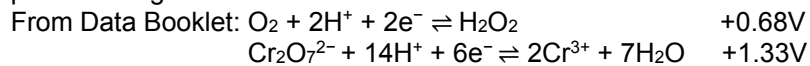

$E_{\text{cell}} = 1.33 - (+0.68) = +0.65\text{V} > 0$, thus reaction is spontaneous.

Option B is incorrect:

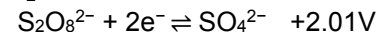
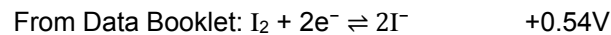

A suitable catalyst will have an E^\ominus value in between +0.54V and +2.01V.

Since $\text{V}^{3+} + \text{e}^- \rightleftharpoons \text{V}^{2+}$ -0.26V

It is not a suitable catalyst.

Option C is correct: Ligand exchange reaction occurred. Water molecules in $[\text{Cu}(\text{H}_2\text{O})_6]^{2+}$ are replaced by Cl^- ions to form $[\text{CuCl}_4]^{2-}$ accounting for the yellow solution.

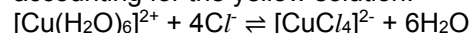

Option D is correct: Hydrolysis reaction occurs for ions with acidic properties such as highly polarising $\text{Cr}^{3+}(\text{aq})$ due to its high charge density.

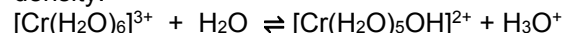

When Na_2CO_3 is added: $\text{CO}_3^{2-} + 2\text{H}_3\text{O}^+ \rightarrow \text{CO}_2 + 3\text{H}_2\text{O}$

The CO_2 evolved gives a white ppt with limewater.

Ans: B

- 30 Option 1 is correct. Lattice energy is the heat released when 1 mole of MgCl_2 is formed from its constituent gaseous ions i.e. $-2526 \text{ kJ mol}^{-1}$.

Option 2 is correct. As seen from the diagram, $\Delta H_{\text{hydration}}$ of Cl^- is -384 kJ mol^{-1} .

Option 3 is correct.

$\Delta H_{\text{solution}} = 2526 + [-1890 + 2(-384)] = -132 \text{ kJ mol}^{-1}$.

Option 4 is correct. The higher energy level, the less thermally stable a species is.

Ans: A

Section A: Structured Questions

Answer **all** the questions in the spaces provided.

- 1 (a) Fig. 1.1 shows the second ionisation energies of eight elements with consecutive proton numbers and one of the elements is aluminium.

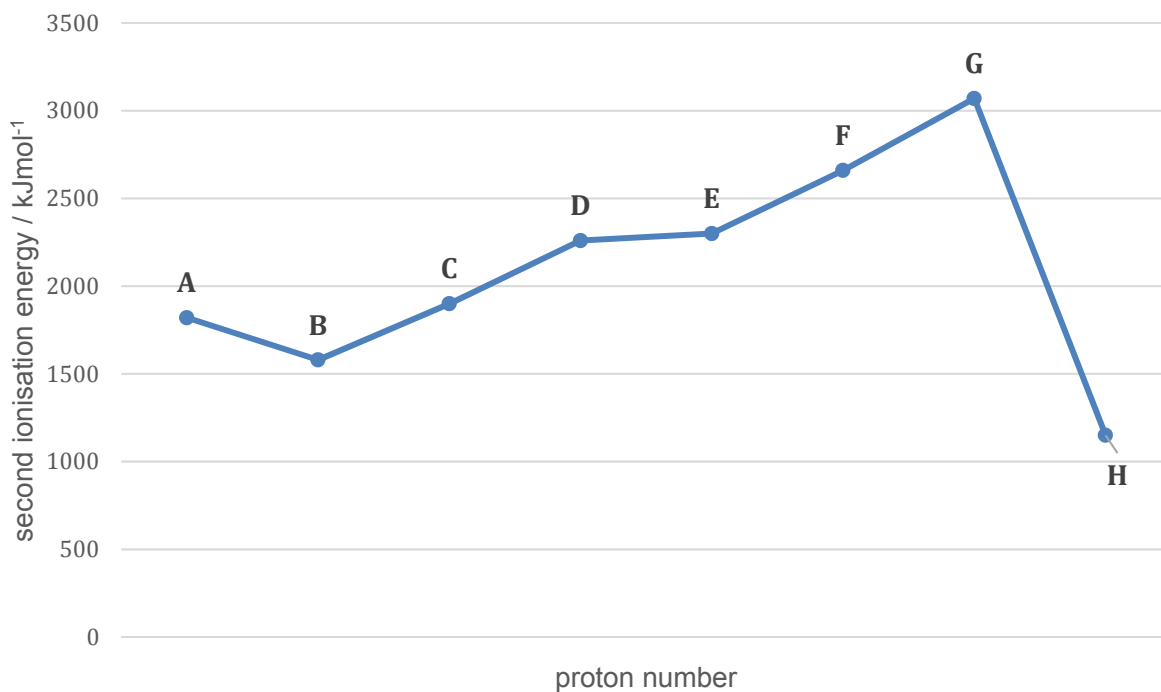

Fig.1.1

- (i) Define, with the aid of an equation, what is meant by the second ionisation energy of aluminium.

.....

.....

.....

[2]

- (ii) Explain why the second ionisation energy of aluminium is usually more endothermic than the first ionisation energy.

.....

.....

.....

.....

[2]

(iii) Identify the element which represents aluminium. Explain the reasoning.

.....

.....

.....

.....

[2]

(b) Hard water is high in dissolved minerals, specifically calcium ions. Although hard water does not pose a health risk, it causes poor soap performance. The soap used in hard water combines with the dissolved minerals to form a sticky soap curd which consists of insoluble salts.

(i) Ethylenediaminetetraacetate or EDTA is a component in laundry detergent.

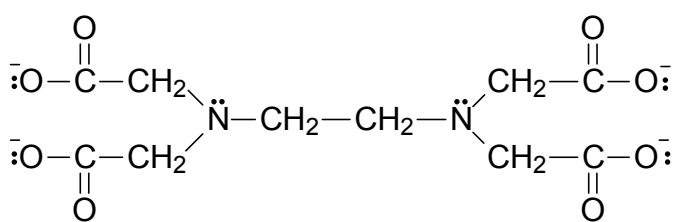

EDTA

Suggest how EDTA could improve the soap performance in hard water.

.....

.....

[1]

(ii) Soap has effective cleaning properties because it contains one or more surfactants.

A surfactant is a molecule with a *non-polar* tail and a *polar* head. An example is sodium stearate, as shown below.

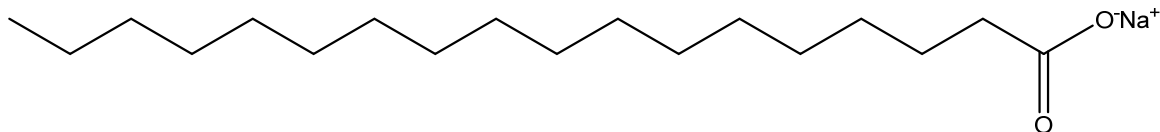

A simplified representation of stearate ion is RCOO^- .

Complete the diagram by drawing the relevant dipoles and indicate the type of intermolecular forces of attraction between stearate ion, an oil molecule and a water molecule. Hence explain how stearate ion helps to remove oil from surface during washing.

You may use R' to represent an oil molecule.

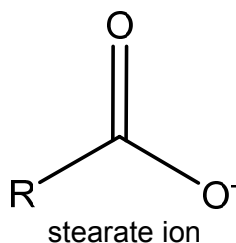

.....

.....

.....

[3]

[Total: 10]

- 2 The table below shows the melting points of some of the chlorides of the elements in period 3 of the periodic table.

Chlorides	Melting points/ °C
Magnesium chloride, MgCl_2	714
Aluminium chloride, AlCl_3	192
Phosphorus pentachloride, PCl_5	161
Sulfur dichloride, SCl_2	-121

- (a) Account, in terms of structure and bonding, the difference in the melting points between

- (i) magnesium chloride and aluminium chloride

.....

.....

.....

.....

[2]

- (ii) phosphorus pentachloride and sulfur dichloride

.....

.....

.....

.....

[2]

- (b) When PCl_5 is added to water, liquid phosphorus oxychloride, POCl_3 is formed as an intermediate compound.

- (i) Reactions of covalent chlorides with water can be rationalised as step-wise replacement of $-\text{Cl}$ with $-\text{OH}$. Deduce a three-step reaction sequence for the formation of POCl_3 from PCl_5 .

Step 1:

Step 2:

Step 3:

[3]

POCl_3 can also act as a *Lewis base* to remove the AlCl_3 at the end of a Friedel–Crafts reaction, resulting in the formation of a covalent product.

(ii) Define the term '*Lewis base*'.

.....
[1]

(iii) Draw a diagram to illustrate the shape of the product which results in the removal of AlCl_3 , stating the type of bonding present and the bond angles around the central atoms.

Type of bonding:

[2]

[Total: 10]

- 3 (a) When steam is passed over hot coke (a form of carbon obtained from coal), water gas is produced. Water gas, consists of a mixture of carbon monoxide and hydrogen, is an important industrial fuel.

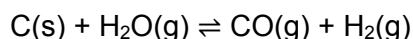

When 0.100 mol of steam was reacted with coke in a vessel of 1.00 dm³ and allowed to reach equilibrium at 800 °C, the partial pressure of steam was found to be 2.67 atm.

- (i) Calculate the initial pressure of steam, in atm, introduced into the vessel.

[2]

- (ii) Using your answer in **a(i)**, calculate a value for K_p , in atm, at 800 °C.

[2]

- (iii) Calculate the minimum mass of carbon required in the vessel.

[2]

- (iv) State and explain whether high or low pressure would favour a higher yield of water gas.

.....

.....

.....

.....

[2]

- (v) The reaction was repeated at a lower temperature and the numerical value of K_p was found to have decreased.

State and explain whether the forward reaction is endothermic or exothermic.

.....

.....

.....

.....

[2]

- (b) (i) The relationship between ΔG^\ominus and K_p for the reaction between carbon and steam is

$$\Delta G^\ominus = -RT \ln K_p$$

where ΔG^\ominus is the standard Gibbs free energy change in J mol^{-1} , R is the gas constant, T is the temperature in Kelvin at which the equilibrium is established and K_p is the equilibrium constant.

Given that the K_p of the reaction at 298 K is 2.97×10^{-18} atm, calculate the ΔG^\ominus of the reaction.

[1]

- (ii) Comment on the sign of ΔG^\ominus with reference to the position of equilibrium of the reaction.

.....

.....

.....

.....

[2]

[Total: 13]

4. (a) Ethers have the general formula, R-O-R' (where R and R' are alkyl or aryl groups).

The most useful method of preparing ethers is by the Williamson ether synthesis, in which an alkoxide ion (RO⁻) reacts with an alkyl halide (R'X) in an S_N2 mechanism.

A reaction scheme is shown below:

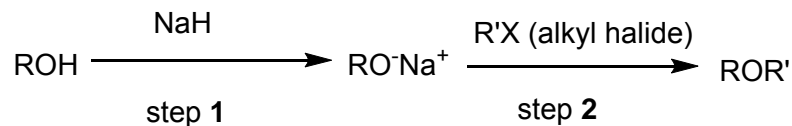

- (i) Suggest why step 1 is necessary in the Williamson ether synthesis.

.....
[1]

- (ii) Using 1-chloropropane as the alkyl halide and CH₃CH₂O⁻ as the alkoxide ion, outline the mechanism for step 2 of the Williamson ether synthesis. Show all charges and relevant lone pairs of electrons and show the movement of electron pairs by using curly arrows.

[3]

- (iii) The same reaction in a(ii) was repeated using iodopropane instead of chloropropane. Using relevant data from the *Data Booklet*, state and explain the effect on the rate of reaction.

.....
.....
.....
.....
[2]

- (iv) Suggest why the product obtained in **a(ii)** shows no optical activity.

.....
 [1]

Fig. 4.1 shows two separate reactions to synthesise ethers using the Williamson ether synthesis method.

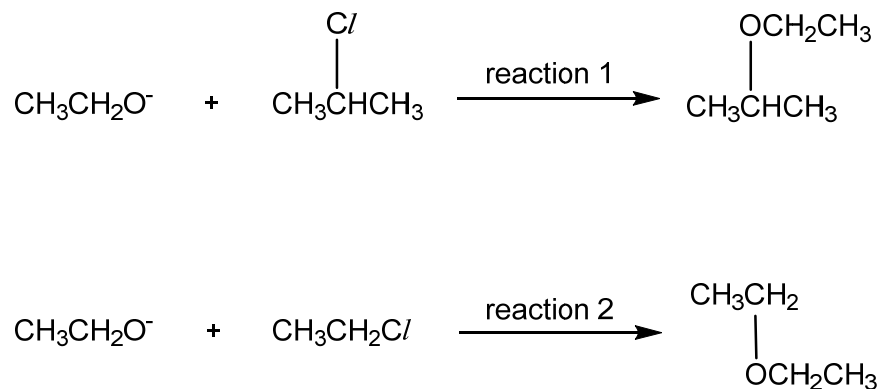
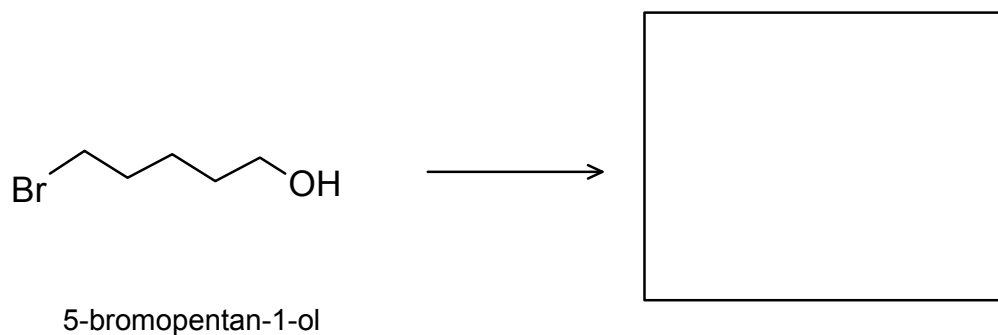

Fig 4.1

- (v) State and explain which reaction will give a higher yield.

.....
 [2]

- (vi) Suggest the structure of the product when 5-bromopentan-1-ol undergoes the Williamson ether reaction.



[1]

- (b) Halogenated organic compounds can be synthesised from various functional groups.

Chlorofluorocarbons (CFCs) have been widely used in aerosol sprays, refrigerants, but are now known to destroy ozone in the upper atmosphere through a free radical chain reaction.

- (i) A student wrongly proposed that a propagation step for the formation of 1-chlorobutane from butane to be:

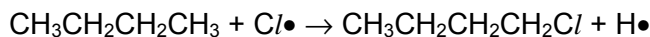

Write the correct propagation step. Hence use relevant data from the *Data Booklet*, calculate the enthalpy change of reaction to explain why the propagation step proposed by the student is incorrect.

.....

.....

.....

.....

.....

[3]

- (ii) 2,5-dimethylhexane is reacted with chlorine in the presence of UV light to form 3 monochlorinated alkanes.

It has been found experimentally that in free radical substitution of alkanes, the primary, secondary and tertiary hydrogen atoms are replaced by chlorine atoms at different rates, as shown in the following table.

type of hydrogen atom	reaction	relative rate
primary	$\text{RCH}_3 \rightarrow \text{RCH}_2\text{Cl}$	1
secondary	$\text{R}_2\text{CH}_2 \rightarrow \text{R}_2\text{CHCl}$	7
tertiary	$\text{R}_3\text{CH} \rightarrow \text{R}_3\text{CCl}$	21

Draw the structural formula of the 3 possible monochlorinated products of 2,5-dimethylhexane and using the information in the table, suggest the relative ratios in which they are formed.

--	--	--

Ratio: : :

[3]

- (c) Another method of preparing alkyl halides from alkenes is by the reaction with N-bromosuccinimide (NBS) in the presence of light to give products which are substituted at the allylic position i.e. the position *next* to the double bond. NBS is used as a source of bromine.

The process is similar to the free radical substitution mechanism of alkanes.

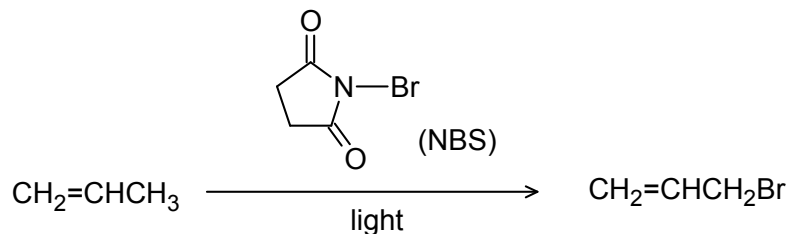

- (i) However, a mixture of 2 products (**W** and **X**) is formed when but-2-ene undergoes this reaction.

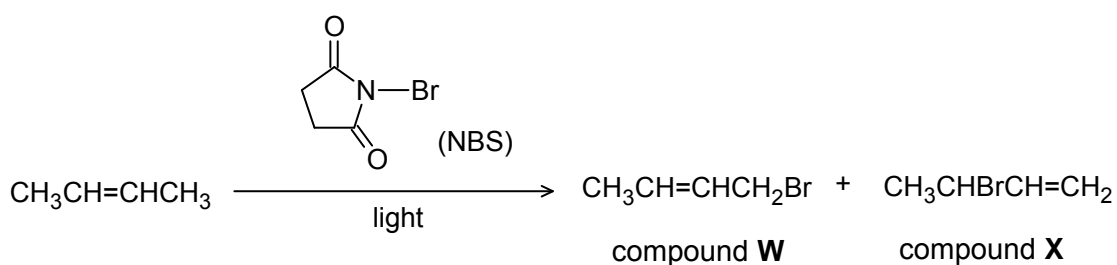

Suggest a reason for the formation of compound **X**.

.....

.....

[2]

- (ii) State the type of isomerism shown by compound **W** and compound **X**.

.....

[1]

[Total: 19]

- 5 Infra-red(IR) absorptions can be used to identify functional groups in organic compounds. For example, ethyl ethanoate shows absorption at $100 - 1300 \text{ cm}^{-1}$ and $1680 - 1750 \text{ cm}^{-1}$.

A student used infra-red spectrometer to obtain an infra-red(IR) spectrum of benzyl alcohol $\text{C}_6\text{H}_5\text{CH}_2\text{OH}$ as shown in Fig. 5.1.

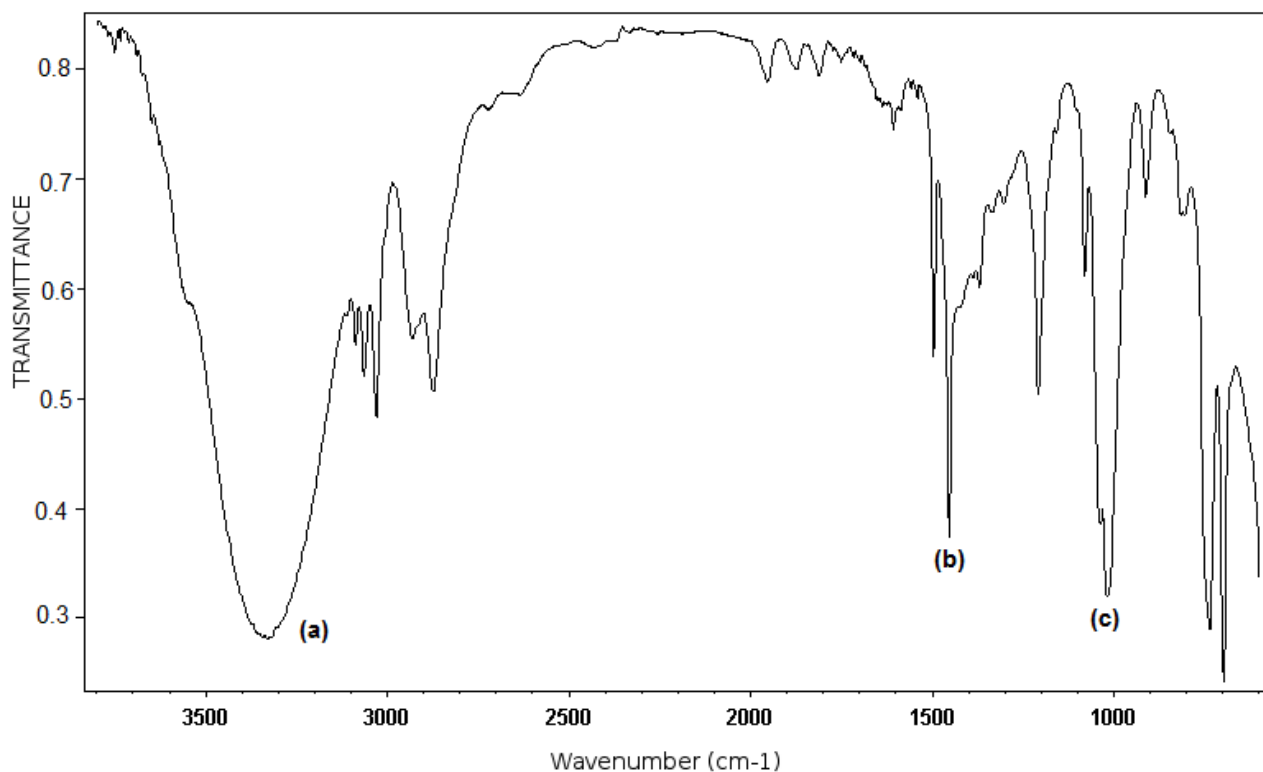

Fig. 5.1

- (a) Use the table of characteristic infra-red absorption frequencies in the *Data Booklet* to identify the infra-red absorption range shown by benzyl alcohol.

IR region	Wavenumbers/ cm^{-1}	Functional groups present
(a)		
(b)		
(c)		

[3]

- (b) The student carried out reflux of benzyl alcohol with acidified potassium dichromate and the product **A** obtained was analysed using IR spectrometer. Fig. 5.2 shows the IR spectrum obtained.

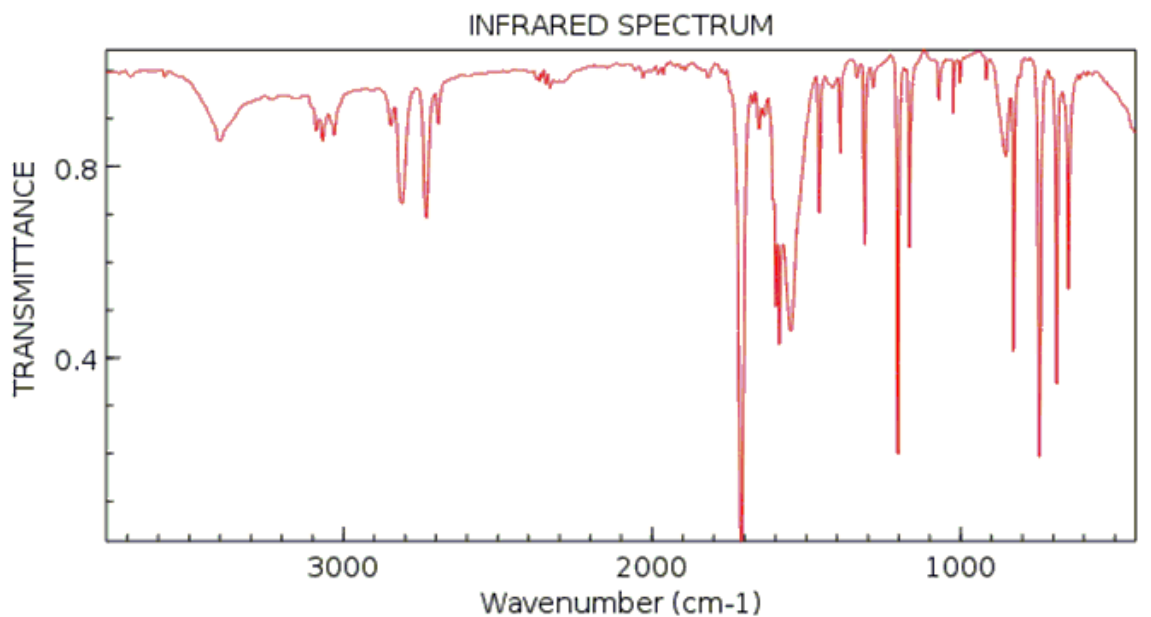

Fig. 5.2

By comparing the two infra-red spectra, suggest two differences from the infra-red spectra and draw the structure of the product **A** obtained.

Product **A**:

.....

.....

.....

[3]

- (c) Suggest a simple chemical test that could be used to confirm benzyl alcohol $C_6H_5CH_2OH$ has been completely converted into product **A** in (b).

Test :

Observations:

.....

[2]

- (d) A student wishes to determine the concentration of product **A** obtained. The student prepares 5 solutions of known concentrations, 0.0100, 0.0200, 0.0400, 0.0800 and 0.100 mol dm⁻³ of product **A**. 10 μL of each solution with the sample was used and a high performance liquid chromatogram was obtained. The peak areas of the chromatographs are given in the table below and a graph of concentration against peak area was obtained in Fig.5.3.

Solution concentration / mol dm ⁻³	0.0100	0.0200	0.0400	0.0800	0.100	sample
Peak area / cm ²	0.50	0.83	1.39	2.63	3.18	2.53

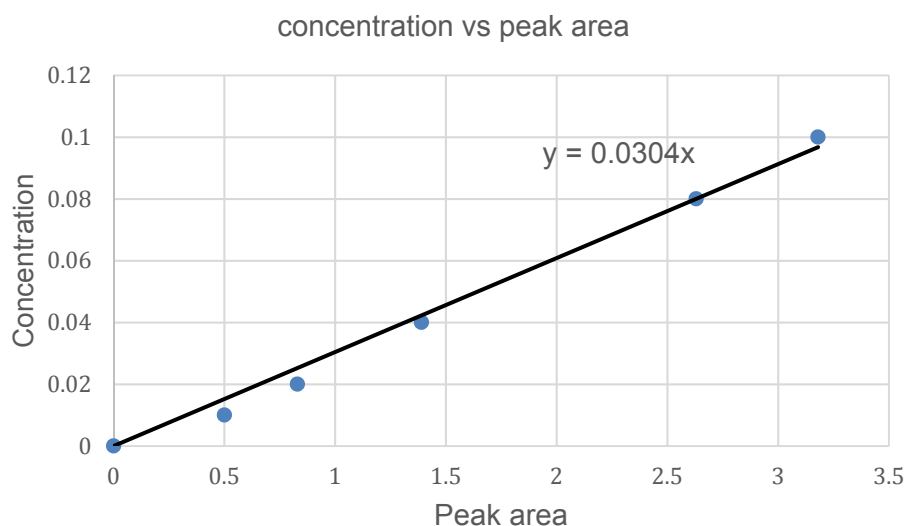

Fig. 5.3

- (i) Using the peak area of the sample from the table and information from the graph, determine the concentration of product **A** in the sample.

[1]

- (ii) Suggest what the student can do to ensure high yield of product **A** from the reaction of benzyl alcohol with acidified potassium dichromate in (b). Use Le Chatelier's Principle to explain your suggestion.

.....

.....

.....

[2]

(e) Fig. 5.4 shows a Ritter reaction.

The Ritter reaction transforms a nitrile to amide using a strong acid and water as follows.

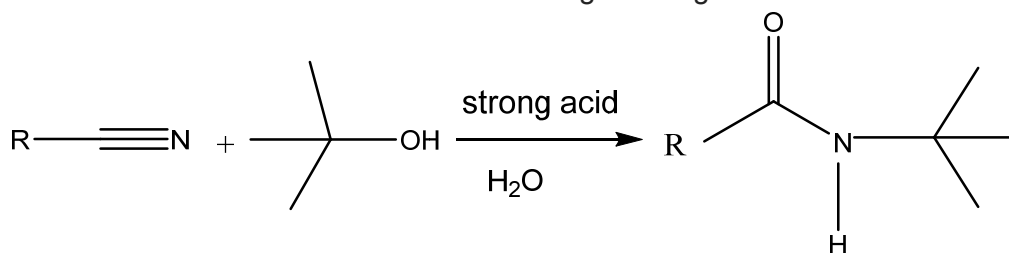

Fig. 5.4

(i) Side products will be formed from the Ritter reaction if heating was carried out.

Suggest the type of reaction which occurs and draw the structures of two side products formed.

Type of reaction:



[3]

(ii) Benzyl alcohol, $C_6H_5CH_2OH$ undergoes Ritter reaction with CH_2CHCN as shown in Fig. 5.4. Draw the structure of the amide formed.

[1]

- (f) Fig. 5.5 shows a possible process in the human body where benzyl alcohol is oxidised to benzoic acid, conjugated with amino acid, glycine in the liver, and excreted as benzoylaminoethanoic acid, as shown.

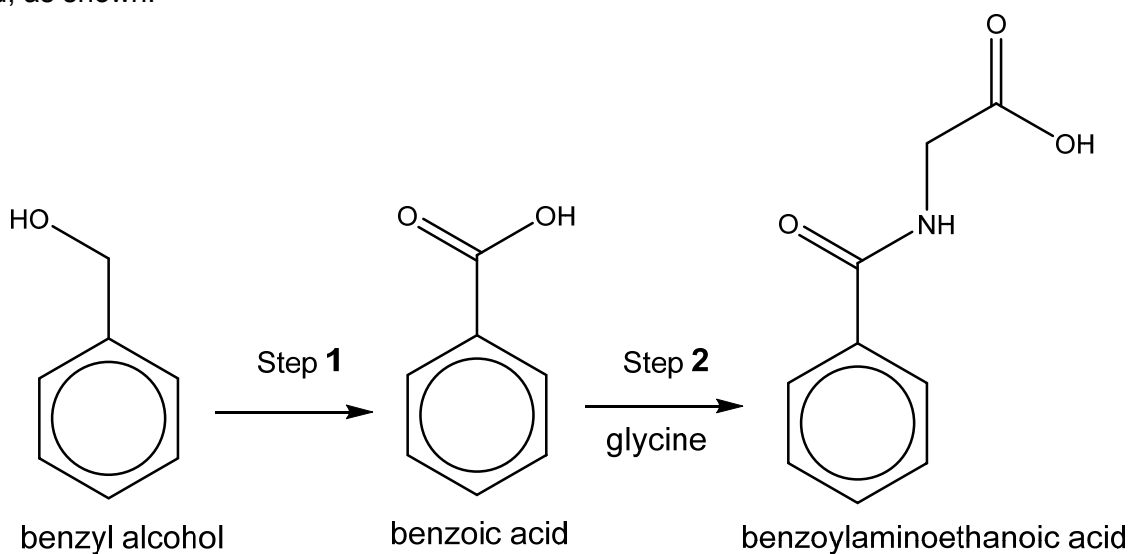

Fig 5.5

- (i) Write an equation for the oxidation of benzyl alcohol to form benzoic acid. Use [O] to represent the formula of the oxidising agent.

.....
[1]

- (ii) What type of reaction takes place in step 2?

.....
[1]

- (iii) Draw the displayed formula of a tripeptide consisting of glycine only.

[1]

- (iv) Benzoylaminoethanoic acid can be reduced by LiAlH_4 in dry ether at room temperature and hydrogen gas with nickel catalyst under high heat and pressure. The organic products formed in the two reactions are different. Compound **B** has a molecular mass of 151 and compound **C** has a molecular mass of 185.

Deduce the structures of **B** and **C**.

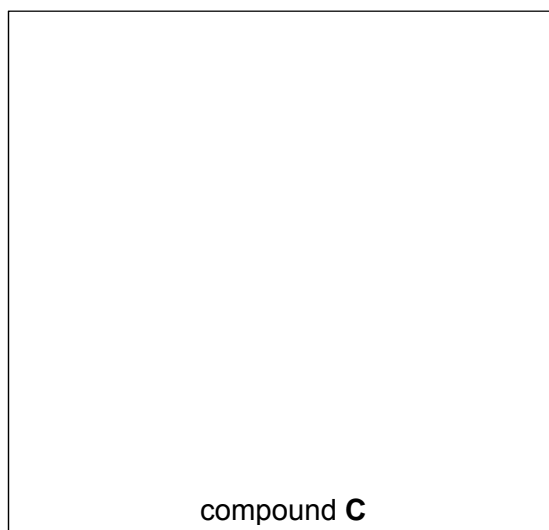
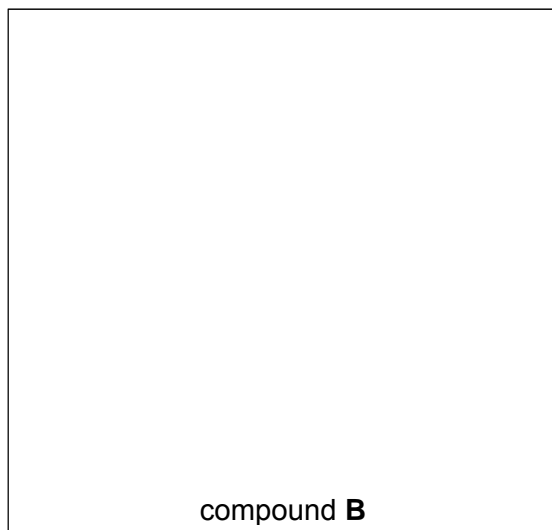

[2]

The synthesis of glycine in the liver is catalysed specifically by glycine synthase enzyme.

- (v) Describe, with the aid of a sketch how the rate of synthesis of glycine is affected by the concentration of the substrate.



[3]

[Total: 23]

Section A: Structured Questions

Answer **all** the questions in the spaces provided.

- 1 (a) Fig. 1.1 shows the second ionisation energies of eight elements with consecutive proton numbers and one of the elements is aluminium.

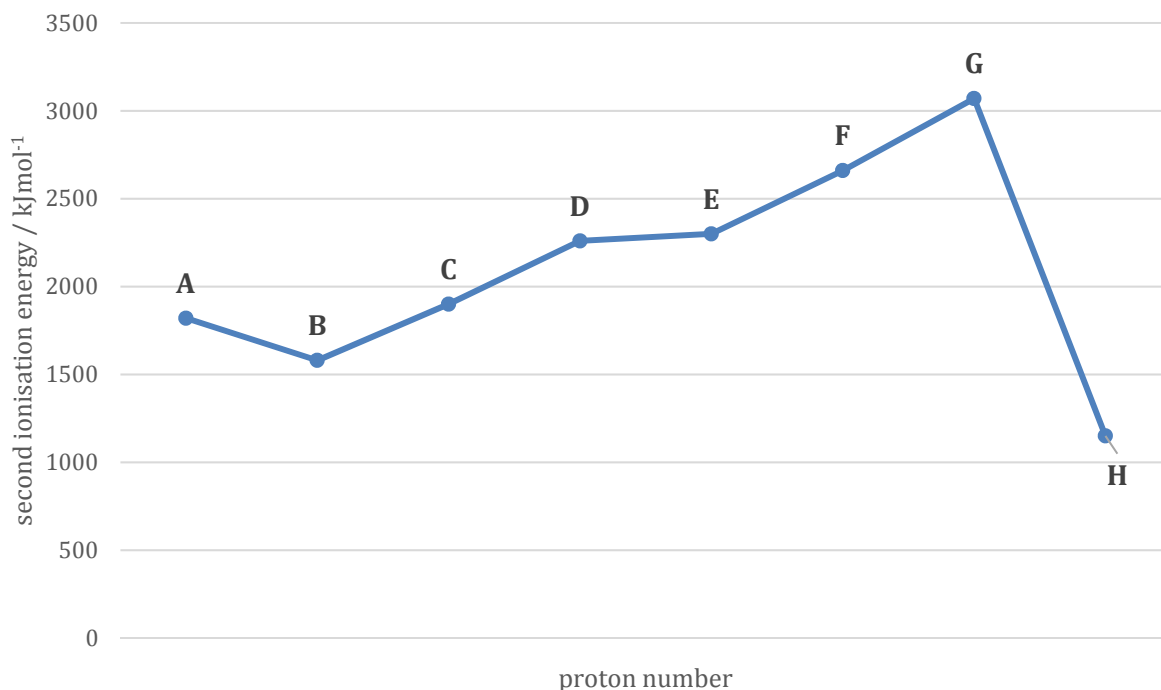

Fig.1.1

- (i) Define, with the aid of an equation, what is meant by the second ionisation energy of aluminium.



Second ionisation energy is the energy required to remove one mole of outermost electrons from one mole of $\text{Al}^+(\text{g})$ cations to form one mole of $\text{Al}^{2+}(\text{g})$ cations.

[2]

- (ii) Explain why the second ionisation energy of aluminium is usually more endothermic than the first ionisation energy.

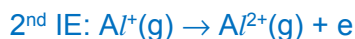
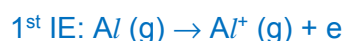

The general increase is due to the increasing positive charge on the cation. As successive electrons are being removed, the same number of protons is attracting fewer electrons.

Consequently, there is an increase in the effective nuclear charge of the cation and requires more energy to remove the next electron.

[2]

- (iii) Identify the element which represents aluminium. Explain the reasoning.

The sharp drop in 2nd IE value from **G** to **H** indicates the removal of the second electron from the inner shell, thus **G** is an element in Group 1. [any other logical deduction]

Element **A** is in Group 13 and is aluminium.

[2]

- (b) Hard water is high in dissolved minerals, specifically calcium ions. Although hard water does not pose a health risk, it causes poor soap performance. The soap used in hard water combines with the dissolved minerals to form a sticky soap curd which consists of insoluble salts.

- (i) Ethylenediaminetetraacetate or EDTA is a component in laundry detergent.

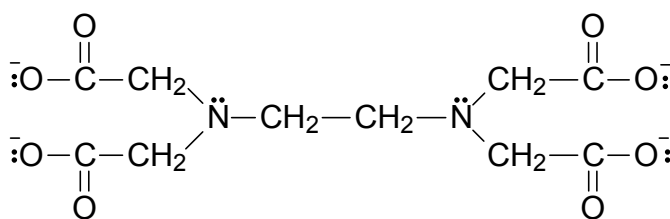

EDTA

Suggest how EDTA could improve the soap performance in hard water.

EDTA forms a complex with metal ion Ca^{2+} , thus removing Ca^{2+} .

[1]

- (ii) Soap has effective cleaning properties because it contains one or more surfactants.

A surfactant is a molecule with a *non-polar* tail and a *polar* head. An example is sodium stearate, as shown below.

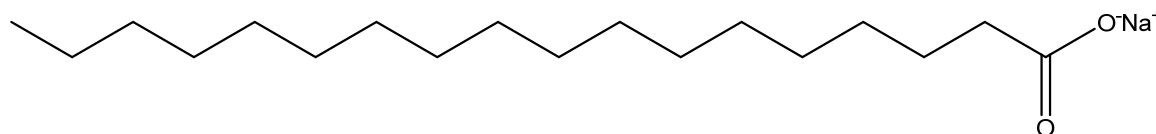

A simplified representation of stearate ion is RCOO^- .

Complete the diagram by drawing the relevant dipoles and indicate the type of intermolecular forces of attraction between stearate ion, an oil molecule and a water molecule. Hence explain how stearate ion helps to remove oil from surface during washing.

You may use R' to represent an oil molecule.

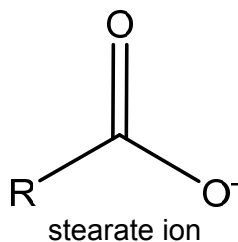

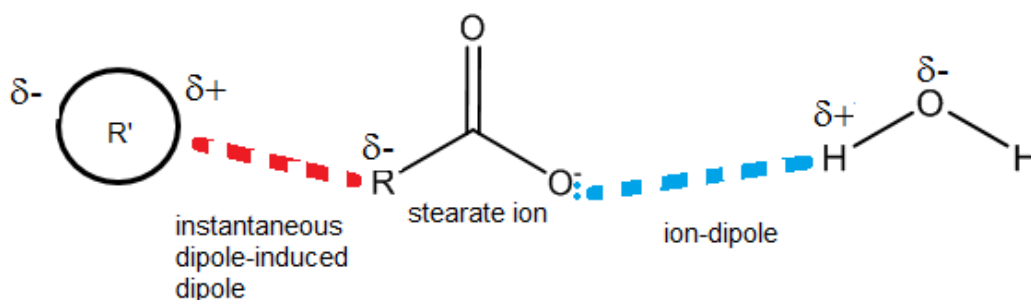

The surfactant/ stearate ion is able to interact with both water and oil - the negatively charged COO^- of the surfactant forms ion-dipole interactions with water, and the non-polar tail forms instantaneous dipole-induced dipole (id-id) interactions with oil (non-polar). Thus it can help to remove oil.

[3]

[Total: 10]

- 2 The table below shows the melting points of some of the chlorides of the elements in period 3 of the periodic table.

Chlorides	Melting points/ °C
Magnesium chloride, MgCl_2	714
Aluminium chloride, AlCl_3	192
Phosphorus pentachloride, PCl_5	161
Sulfur dichloride, SCl_2	-121

- (a) Account, in terms of structure and bonding, the difference in the melting points between

- (i) magnesium chloride and aluminium chloride

MgCl_2 has a giant ionic structure while AlCl_3 has a simple molecular structure.

More energy is required to overcome the electrostatic forces of attraction between Mg^{2+} and Cl^- compared to instantaneous dipole-induced dipole attraction between AlCl_3 molecules. Hence MgCl_2 should have a higher melting point.

[2]

- (ii) phosphorus pentachloride and sulfur dichloride

Both PCl_5 and SCl_2 have simple molecular structure.

PCl_5 has larger and more polarisable electron cloud than SCl_2 . More energy is required to overcome the stronger instantaneous dipole-induced dipole attraction between molecules of PCl_5 compared to molecules of SCl_2 . Hence PCl_5 should have a higher melting point.

[2]

(b) When PCl_5 is added to water, liquid phosphorus oxychloride, POCl_3 is formed as an intermediate compound.

(i) Reactions of covalent chlorides with water can be rationalised as step-wise replacement of $-\text{Cl}$ with $-\text{OH}$. Deduce a three-step reaction sequence for the formation of POCl_3 from PCl_5 .

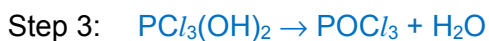

[3]

POCl_3 can also act as a *Lewis base* to remove the AlCl_3 at the end of a Friedel-Crafts reaction, resulting in the formation of a covalent product.

(ii) Define the term '*Lewis base*'.

A Lewis base is an electron-pair donor.

[1]

(iii) Draw a diagram to illustrate the shape of the product which results in the removal of AlCl_3 , stating the type of bonding present and the bond angles around the central atoms.

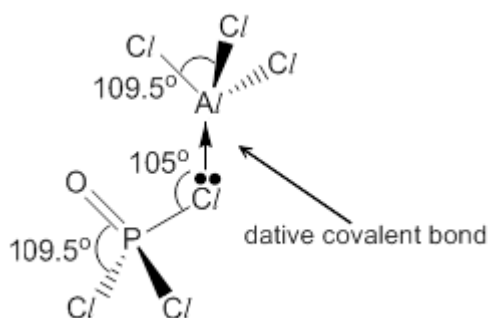

Type of bonding: **Dative covalent bond**, (accept if student draw O to Al.)

[2]

[Total: 10]

- 3 (a) When steam is passed over hot coke (a form of carbon obtained from coal), water gas is produced. Water gas, consists of a mixture of carbon monoxide and hydrogen, is an important industrial fuel.

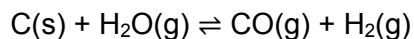

When 0.100 mol of steam was reacted with coke in a vessel of 1.00 dm³ and allowed to reach equilibrium at 800 °C, the partial pressure of steam was found to be 2.67 atm.

- (i) Calculate the initial pressure of steam, in atm, introduced into the vessel.

Using $pV = nRT$

$$p = \frac{(0.1 \times 8.31 \times (800 + 273))}{(1 \times 10^{-3})} = 8.9166 \times 10^5 \text{ Pa} = 8.80 \text{ atm} \quad (1 \text{ atm} = 101325 \text{ Pa})$$

[2]

- (ii) Using your answer in a(i), calculate a value for K_p , in atm, at 800 °C.

	C(s)	H ₂ O(g)	CO(g)	H ₂ (g)
Initial P/atm	-	8.80	0	0
Change/atm	-	- 6.13	+6.13	+6.13
Equilibrium P/atm	-	2.67	6.13	6.13

$$K_p = \frac{p_{\text{CO}} p_{\text{H}_2}}{p_{\text{H}_2\text{O}}} = \frac{(6.13)^2}{2.67} = 14.1 \text{ atm}$$

[2]

- (iii) Calculate the minimum mass of carbon required in the vessel.

Since 6.13 atm of steam was reacted,

$$\text{number of moles of steam} = \frac{pV}{RT} = \frac{(6.13 \times 101325 \times 10^{-3})}{8.31 \times (800 + 273)} = 0.06966 \text{ mol}$$

$$\text{Mass of C} = 0.06966 \times 12.0 = 0.836 \text{ g}$$

[2]

- (iv) State and explain whether high or low pressure would favour a higher yield of water gas.

To obtain higher yield, the position of equilibrium must shift to the right.

Since the forward reaction produces greater number of moles of gaseous molecules, low pressure favours higher yield.

[2]

- (v) The reaction was repeated at a lower temperature and the numerical value of K_p was found to have decreased.

State and explain whether the forward reaction is endothermic or exothermic.

At low temperature, K_p value decreased. This shows that the equilibrium position shifts to the left which produces heat (exothermic).

Hence forward reaction is endothermic.

[2]

- (b) (i) The relationship between ΔG^\ominus and K_p for the reaction between carbon and steam is

$$\Delta G^\ominus = -RT \ln K_p$$

where ΔG^\ominus is the standard Gibbs free energy change in J mol^{-1} , R is the gas constant, T is the temperature in Kelvin at which the equilibrium is established and K_p is the equilibrium constant.

Given that the K_p of the reaction at 298K is $2.97 \times 10^{-18} \text{ atm}$, calculate the ΔG^\ominus of the reaction under standard conditions.

$$\begin{aligned} \Delta G^\ominus &= -8.31 (298) \ln (2.97 \times 10^{-18} \times 101325) \\ &= +7.14 \times 10^4 \text{ J mol}^{-1} \end{aligned}$$

[1]

- (ii) Comment on the sign of ΔG^\ominus with reference to the position of equilibrium of the reaction under standard condition.

The sign of ΔG^\ominus is positive, the reaction is not spontaneous under standard conditions and position of equilibrium lies to the left.

[2]

[Total: 13]

4. (a) Ethers have the general formula, $\text{R-O-R}'$ (where R and R' are alkyl or aryl groups).

The most useful method of preparing ethers is by the Williamson ether synthesis, in which an alkoxide ion (RO^-) reacts with an alkyl halide ($\text{R}'\text{X}$) in an $\text{S}_{\text{N}}2$ mechanism.

A reaction scheme is shown below:

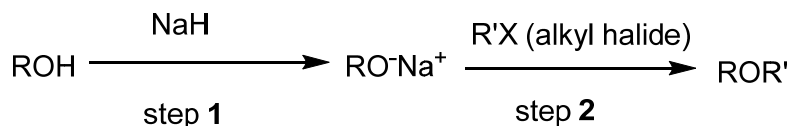

- (i) Suggest why step 1 is necessary in the Williamson ether synthesis.

To generate a stronger nucleophile

[1]

- (ii) Using 1-chloropropane as the alkyl halide and $\text{CH}_3\text{CH}_2\text{O}^-$ as the alkoxide ion, outline the mechanism for **step 2** of the Williamson ether synthesis. Show all charges and relevant lone pairs of electrons and show the movement of electron pairs by using curly arrows.

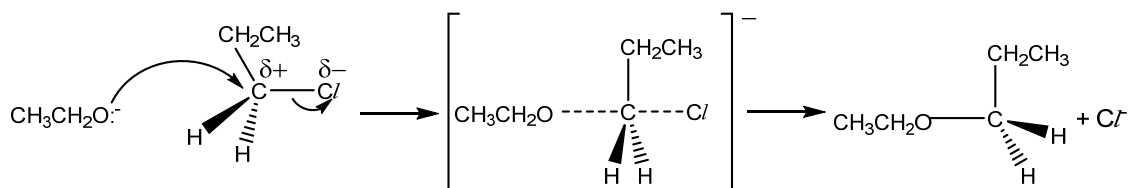

[3]

- (iii) The same reaction in **a(ii)** was repeated using iodopropane instead of chloropropane. Using relevant data from the *Data Booklet*, state and explain the effect on the rate of reaction.

The rate of reaction using iodopropane will be faster.

From the Data Booklet,

Bond Energy (C-Cl) = 340 kJmol⁻¹;

Bond energy (C-I) = 240 kJmol⁻¹.

The C-I bond is weaker, thus less energy is needed to break the bond.

[2]

- (iv) Suggest why the product obtained in **a(ii)** shows no optical activity.

There is absence of chiral carbon, thus it is unable to form enantiomers.

[1]

Fig. 4.1 shows two possible reaction sequence to synthesise compound **P**.

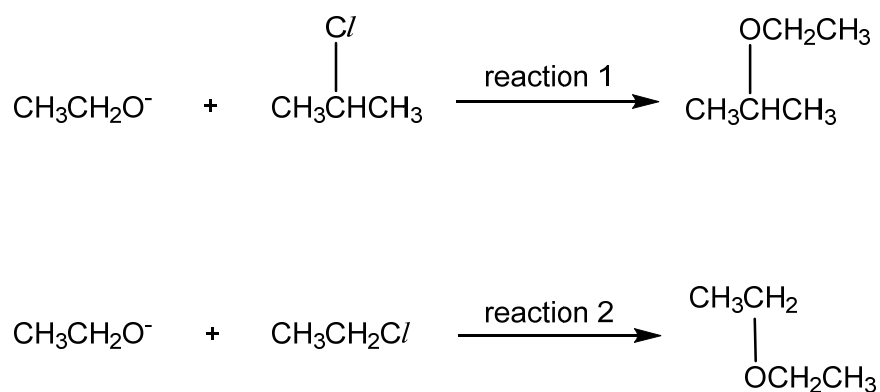

Fig 4.1

- (v) State and explain which reaction will give a higher yield.
Reaction 2 will give higher yield.

The Williamson ether synthesis method proceeds via S_N2 mechanism which is favoured by primary halogenoalkane as there is less steric hindrance posed to the attacking nucleophile.

[2]

- (vi) Suggest the structure of the product when 5-bromo-pentan-1-ol undergoes the Williamson ether reaction.

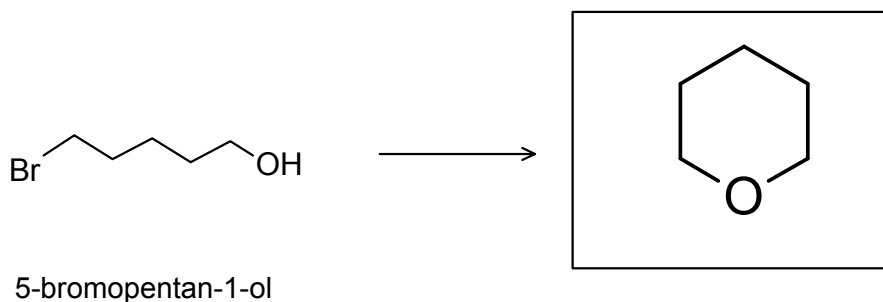

[1]

- (b) Halogenated organic compounds can be synthesised from various functional groups.

Chlorofluorocarbons (CFCs) have been widely used in aerosol sprays, refrigerants, but are now known to destroy ozone in the upper atmosphere through a free radical chain reaction.

- (i) A student wrongly proposed that a propagation step for the formation of 1-chlorobutane from butane to be:

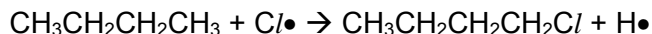

Write the correct propagation step. Hence use relevant data from the *Data Booklet*, calculate the enthalpy change of reaction to explain why the propagation step proposed by the student is incorrect.

The correct propagation step is:



$$\text{BE (C - H)} = 410 \text{ kJ mol}^{-1} \quad \text{BE (H - Cl)} = 431 \text{ kJ mol}^{-1} ; \quad \text{BE (C - Cl)} = 340 \text{ kJ mol}^{-1}$$

$$\Delta H_r \text{ for the incorrect propagation step is } 410 - 340 = +70 \text{ kJ mol}^{-1}$$

$$\Delta H_r \text{ for the correct propagation step is } 410 - 431 = -21 \text{ kJ mol}^{-1}$$

Since the ΔH_r for the correct propagation step is more exothermic, the reaction is more spontaneous.

[3]

- (ii) 2,5-dimethylhexane is reacted with chlorine in the presence of UV light to form 3 monochlorinated alkanes.

It has been found experimentally that in free radical substitution of alkanes, the primary, secondary and tertiary hydrogen atoms are replaced by chlorine atoms at different rates, as shown in the following table.

type of hydrogen atom	reaction	relative rate
primary	$\text{RCH}_3 \rightarrow \text{RCH}_2\text{Cl}$	1
secondary	$\text{R}_2\text{CH}_2 \rightarrow \text{R}_2\text{CHCl}$	7
tertiary	$\text{R}_3\text{CH} \rightarrow \text{R}_3\text{CCl}$	21

Draw the structural formula of the 3 possible monochlorinated products of 2,5-dimethylhexane and using the information in the table, suggest the relative ratios in which they are formed.

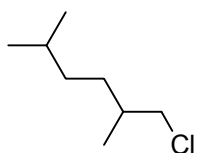

$$\text{Ratio} \quad (12 \times 1) = 12$$

$$6$$

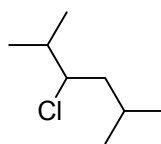

$$(4 \times 7) = 28$$

$$14$$

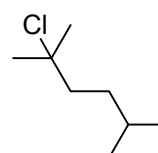

$$(2 \times 21) = 42$$

$$21$$

[3]

- (c) Another method of preparing alkyl halides from alkenes is by the reaction with N-bromosuccinimide (NBS) in the presence of light to give products which are substituted at the allylic position i.e. the position *next* to the double bond. NBS is used as a source of bromine.

The process is similar to the free radical substitution mechanism of alkanes.

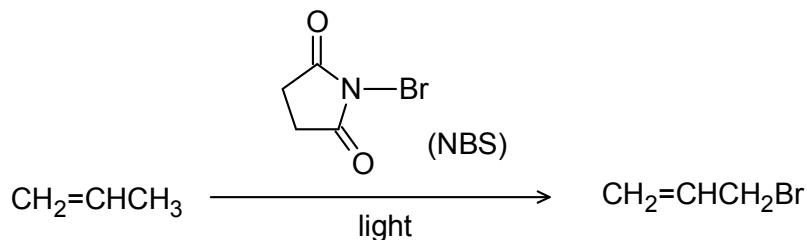

- (i) However, a mixture of 2 products (**W** and **X**) is formed when but-2-ene undergoes this reaction.

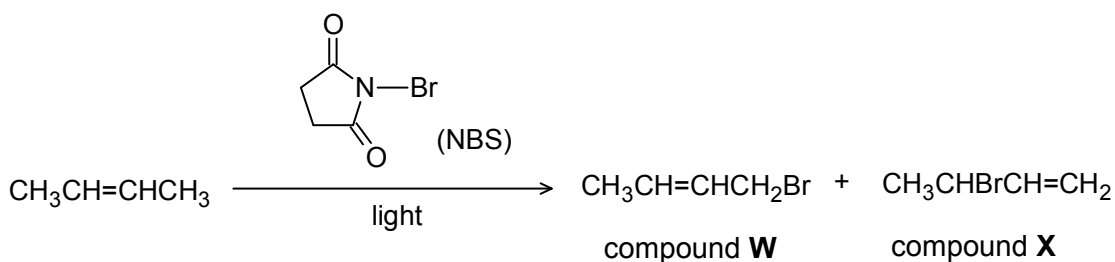

Suggest a reason for the formation of compound **X**.

Another resonance structure can be obtained due to the delocalisation of the electron.

secondary radical is more stable than primary radical as it has more electron-donating group or



[2]

- (ii) State the type of isomerism shown by compound **W** and compound **X**.

They are constitutional / positional isomers.

[1]

[Total: 19]

- 5 Infra-red(IR) absorptions can be used to identify functional groups in organic compounds. For example, ethyl ethanoate shows absorption at $100 - 1300 \text{ cm}^{-1}$ and $1680 - 1750 \text{ cm}^{-1}$.

A student used infra-red spectrometer to obtain an infra-red(IR) spectrum of benzyl alcohol $\text{C}_6\text{H}_5\text{CH}_2\text{OH}$ as shown in Fig. 5.1.

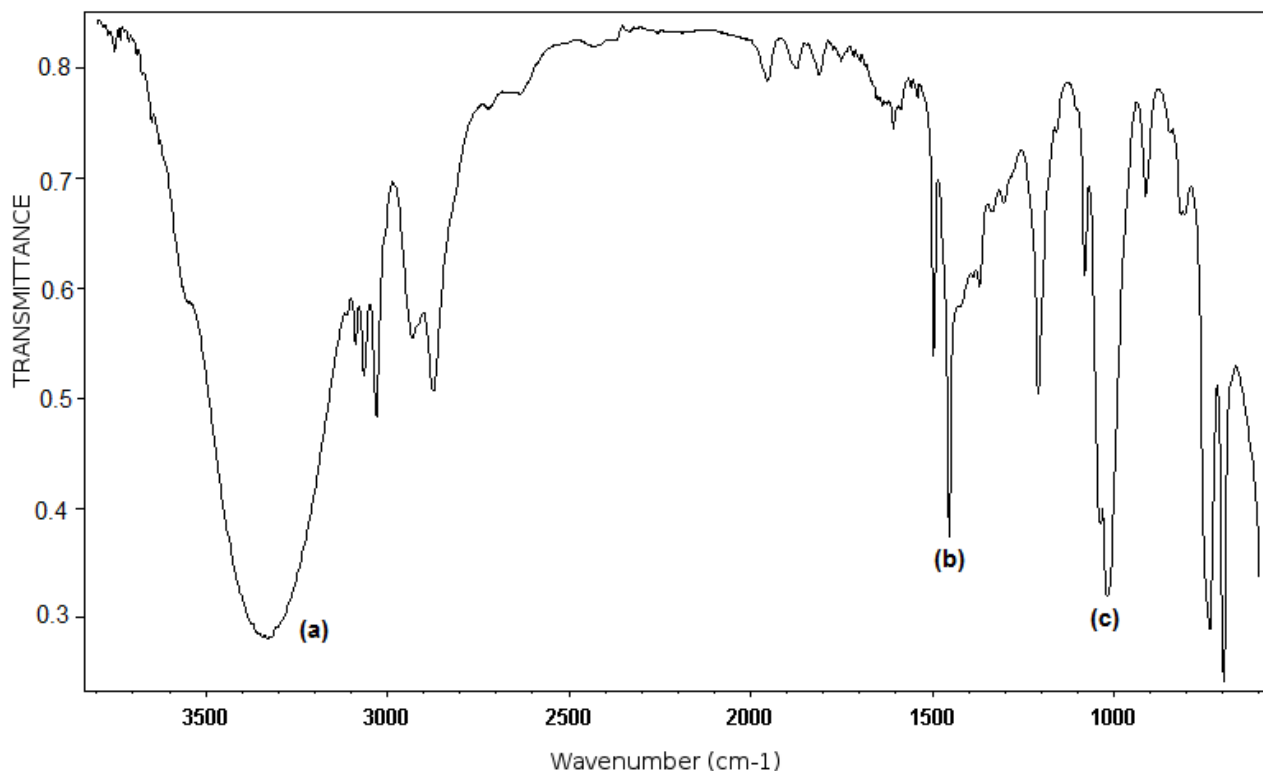

Fig. 5.1

- (a) Use the table of characteristic infra-red absorption frequencies in the *Data Booklet* to identify the infra-red absorption range shown by benzyl alcohol.

IR region	Wavenumbers/ cm^{-1}	Functional groups present
(a)	3200 – 3600	(Primary) alcohol
(b)	1475 – 1625	Benzene
(c)	970 – 1260	(Primary) alcohol

[3]

- (b) The student carried out reflux of benzyl alcohol with acidified potassium dichromate and the product **A** obtained was analysed using spectrometer. Fig. 5.2 shows the IR spectrum obtained.

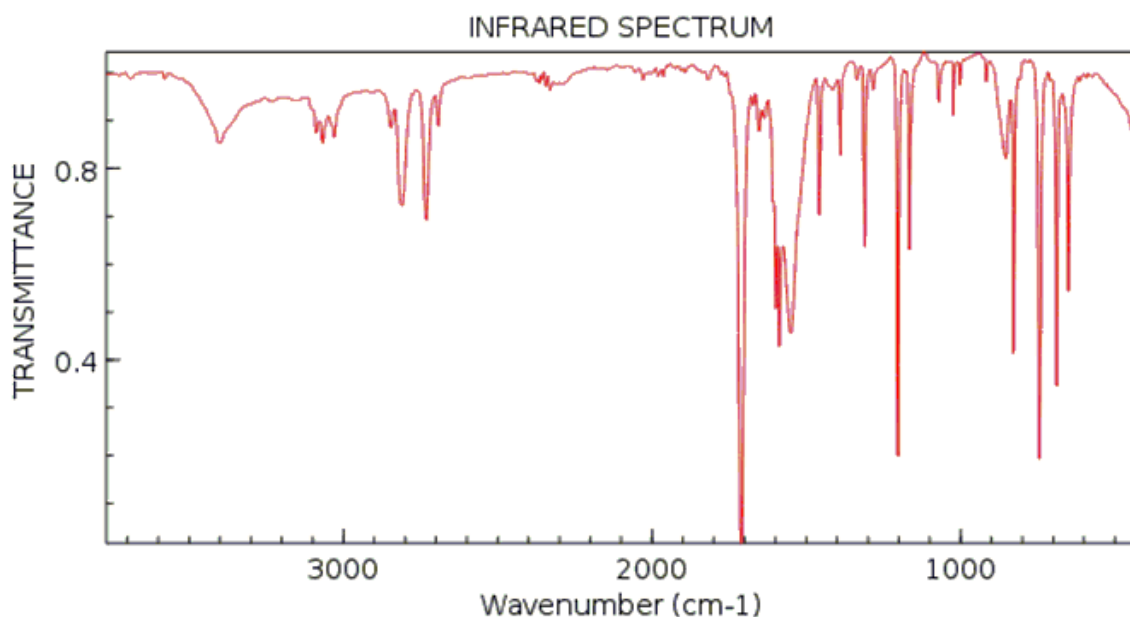
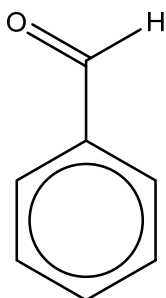

Fig. 5.2

By comparing the two infra-red spectra, suggest two differences from the infra-red spectra and draw the structure of the product **A** obtained.

Product **A**:



1. Peak (a) from Fig 5.1 is missing compared to Fig 5.2., indicating loss of –OH group
2. Presence of C=O at 1670–1740 cm⁻¹ in Fig 5.2 compared to Fig 5.1, could be due to aldehyde group

Note: RCOOH is not acceptable as there is no O–H absorption from 2500-3000 cm⁻¹ in Fig 5.2

[3]

- (c) Suggest a simple chemical test that could be used to confirm benzyl alcohol C₆H₅CH₂OH has been completely converted into product **A** in (b).

Test : Add anhydrous SOCl₂, PCl₅ or Na(s)

Absence of HCl/ white fumes confirmed that there is no alcohol present or

Observations: absence of effervescence of H₂ gas.

[2]

- (d) A student wishes to determine the concentration of product **A** obtained. The student prepares 5 solutions of known concentrations, 0.0100, 0.0200, 0.0400, 0.0800 and 0.100 mol dm⁻³ of product **A**. 10 μL of each solution with the sample was used and a high performance liquid chromatogram was obtained. The peak areas of the chromatographs are given in the table below and a graph of concentration against peak area was obtained in Fig.5.3.

Solution concentration / mol dm ⁻³	0.0100	0.0200	0.0400	0.0800	0.100	sample
Peak area / cm ²	0.50	0.83	1.39	2.63	3.18	2.53

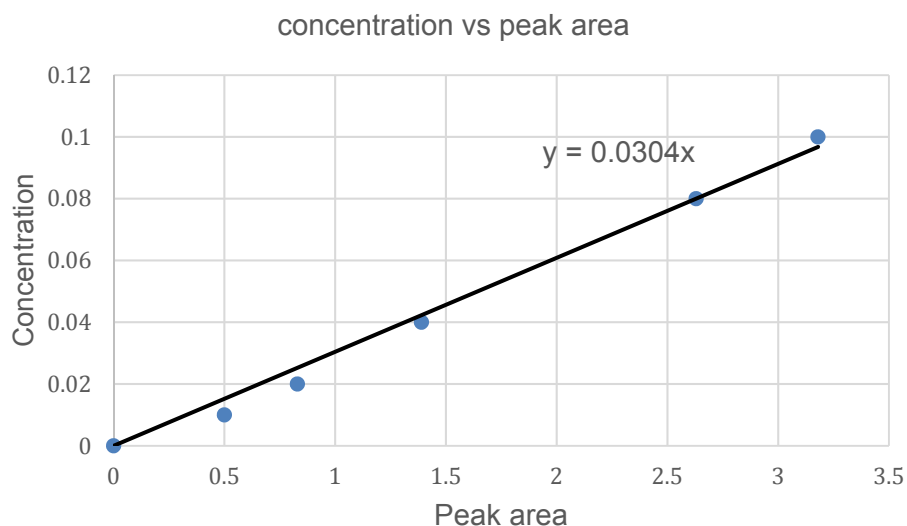

Fig. 5.3

- (i) Using the peak area of the sample from the table and information from the graph, determine the concentration of product **A** in the sample.

$$\text{Concentration of product A} = 0.0304(2.53) = 0.0769 \text{ mol dm}^{-3}$$

[1]

- (ii) Suggest what the student can do to ensure high yield of product **A** from the reaction of benzyl alcohol with acidified potassium dichromate in (b). Use Le Chatelier's Principle to explain your suggestion.



Carry out immediate distillation of product **A**.

As product **A** is being removed, position of equilibrium shifts right to increase the concentration of product **A**, hence yield increases.

[2]

(e) Fig. 5.4 shows a Ritter reaction.

The Ritter reaction transforms a nitrile to amide using a strong acid and water as follows.

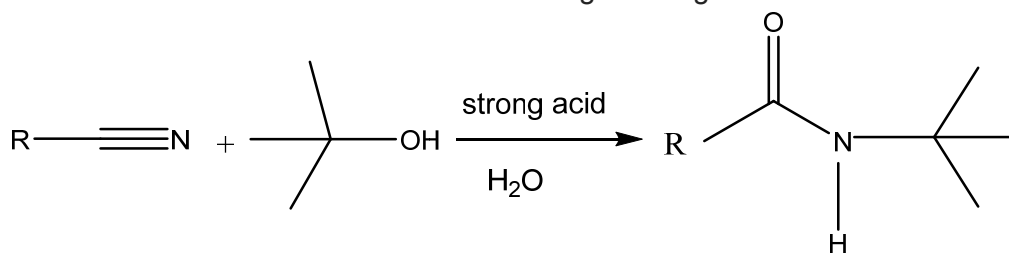
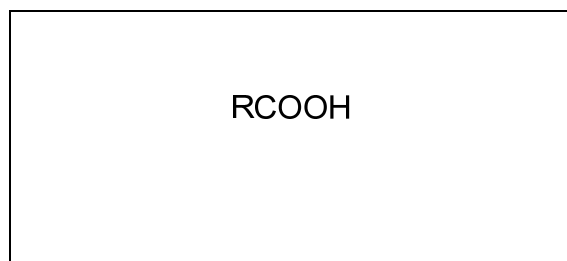
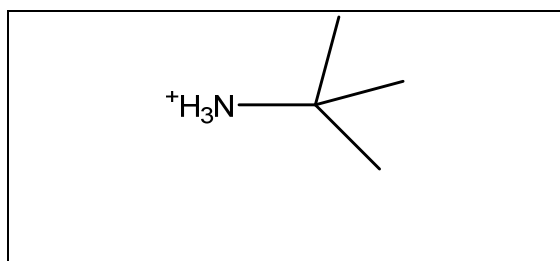

Fig. 5.4

(i) Side products will be formed from the Ritter reaction if heating was carried out.

Suggest the type of reaction which occurs and draw the structures of two side products formed.

Type of reaction: Hydrolysis



[3]

(ii) Benzyl alcohol, $C_6H_5CH_2OH$ undergoes Ritter reaction with $CH_2=CHCN$ as shown in Fig. 5.4. Draw the structure of the amide formed.

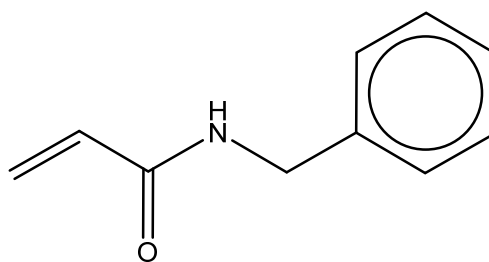

- (iv) Benzoylaminoethanoic acid can be reduced by LiAlH_4 in dry ether at room temperature and hydrogen gas with nickel catalyst under high heat and pressure. The organic products formed in the two reactions are different. Compound **B** has a molecular mass of 151 and compound **C** has a molecular mass of 185.

Deduce the structures of **B** and **C**.

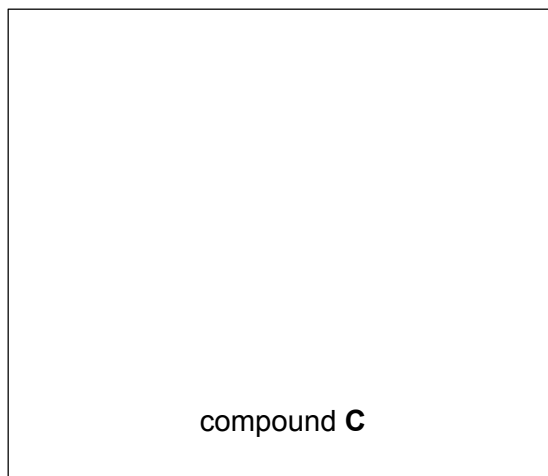
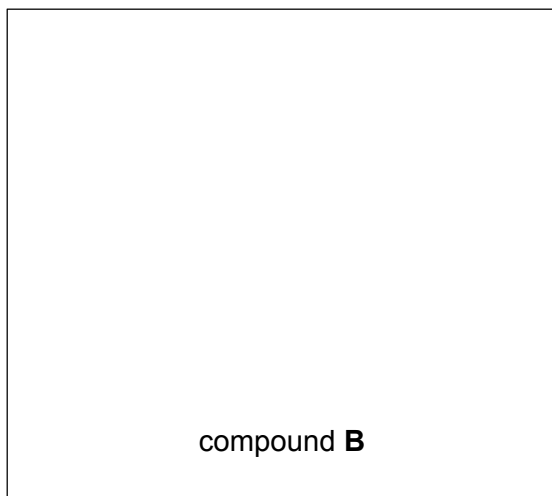

[2]

The synthesis of glycine in the liver is catalysed specifically by glycine synthase enzyme.

- (v) Describe, with the aid of a sketch how the rate of synthesis of glycine is affected by the concentration of the substrate.

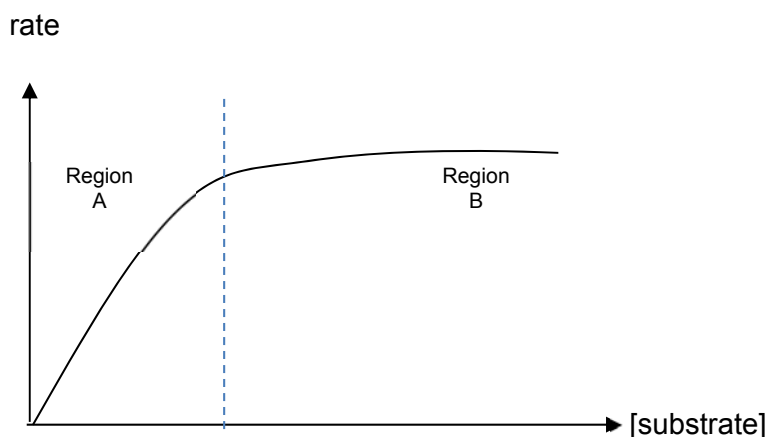

At low [substrate], the active sites are not filled and $\text{rate} = k [\text{substrate}]$; i.e. rate is proportional to [substrate] and the reaction is first order wrt [substrate] (region A).

At high [substrate], increasing its concentration has no effect at all on the rate of reaction; as all the active sites are occupied. i.e. reaction is zero order with respect to [substrate] (region B).

[3]

[Total: 23]

CANDIDATE'S NAME: _____

CTG: _____

YISHUN JUNIOR COLLEGE
2018 JC2 PRELIMINARY EXAMINATION

CHEMISTRY
HIGHER 2

9729/03

Paper 3 Free Response

MONDAY 10 SEPTEMBER 2018
1400hrs – 1600hrs
2 hours

Candidates answer on separate paper.

Additional Materials: Writing Papers
Data Booklet



READ THESE INSTRUCTIONS FIRST

Write your name and CTG on all the work that you hand in.
Write in dark blue or black pen on both sides of the paper.
You may use a soft pencil for any diagrams, graphs or rough working.
Do not use paper clips, highlighters, glue or correction fluid.

Section A
Answer **all** questions.

Section B
Answer **one** question.

A Data Booklet is provided.
The use of an approved calculator is expected, where appropriate.

At the end of the examination, fasten all your work securely together with the cover page on top.
The number of marks is given in brackets [] at the end of each question or part question.

Section A (60 marks)

Answer **all** the questions in this section on the writing papers provided.

- 1 (a) A student designed an ion-specific probe to determine the concentration of H^+ ions in solution. He connected a hydrogen electrode to a calomel reference electrode, which comprises a paste of mercury(I) chloride, Hg_2Cl_2 , and mercury in a saturated chloride electrolyte. The reference electrode is inserted into a glass tube with a porous base.

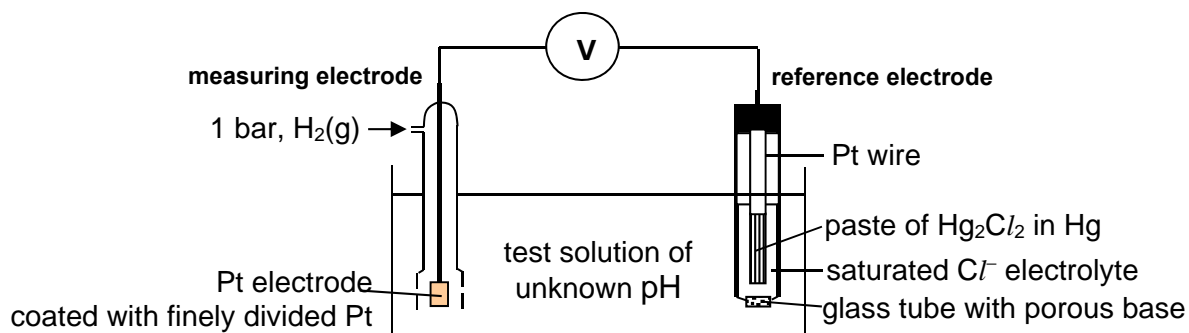

The hydrogen electrode, which is sensitive to H^+ ion concentration, is the measuring electrode. Therefore, this galvanic cell acts as a pH meter.

When both electrodes are in contact with the test solution, an electric current flows through the wire and mercury(I) chloride reacts to form liquid mercury and chloride ion at the reference electrode.

Under standard conditions, the E^\ominus_{cell} of the pH meter is +0.28 V.

- (i) Suggest the use of the glass tube with a porous base in this experimental set-up. [1]
- (ii) Identify the half-cell containing the anode. [1]
- (iii) Construct the half equation for the reaction occurring at the reference electrode. [1]
- (iv) Hence write an overall balanced equation for the pH meter. [1]
- (v) Determine the ΔG^\ominus of this reaction and state the units. [2]
- (vi) Explain why the cell potential would increase when the pH meter is placed in a solution of a higher pH. [1]

- (b) The student used his probe in (a) to analyse a sample of mandelic acid, a bitter almond extract that is used as an antibacterial treatment.

The student obtained a cell potential reading, E_{cell} , of +0.41 V.

The *Nernst equation* can be used to calculate the concentration of H^+ ions detected by the probe:

$$E_{\text{cell}} = E_{\text{cell}}^{\circ} - \frac{0.0592}{n} \log_{10} \left(\frac{[\text{H}^+]^2 [\text{Cl}^-]^2}{P_{\text{H}_2}} \right)$$

where n is the number of moles of electrons transferred in the overall reaction,

$[\text{H}^+]$ is the concentration of hydrogen ions detected,

$[\text{Cl}^-]$ is the concentration of Cl^- ions,

P_{H_2} is the pressure, in bar, of hydrogen gas passed into the probe.

Assuming that the concentration of Cl^- is constant at 1 mol dm^{-3} , use the *Nernst equation* to calculate the concentration of H^+ ions in the solution and the pH of the solution.

[2]

- (c) A current is passed through three cells connected in series as shown below.

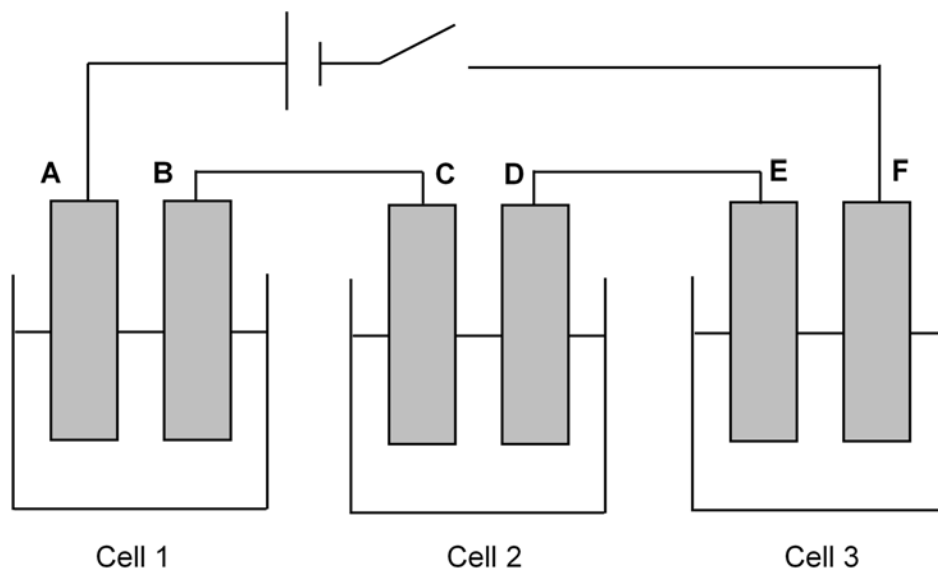

Cell 1 contains lead electrodes, **A**, **B** and electrolyte $\text{Pb}(\text{NO}_3)_2(\text{aq})$.

Cell 2 contains platinum electrodes, **C**, **D** and electrolyte $\text{NaBr}(\text{aq})$.

Cell 3 contains platinum electrodes, **E**, **F** and electrolyte containing $\text{MnCl}_x(\text{aq})$.

- (i) On closing the switch, write equations, including state symbols, for the reactions occurring at electrodes **A** and **D**.

[2]

- (ii) A current of 0.36 A was passed through the circuit for 30 minutes. 0.183 g of manganese was deposited in Cell 3. Determine the value of x in MnCl_x .

[3]

(d) Identify the structures of compounds **A**, **B**, **C** and **D** and suggest the reagents and conditions for each numbered steps **I**, **II** and **III** where possible.

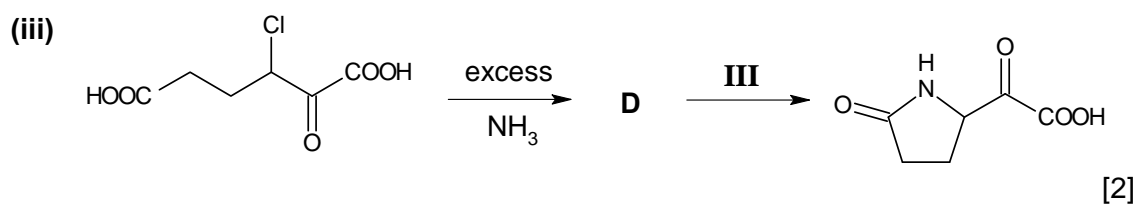
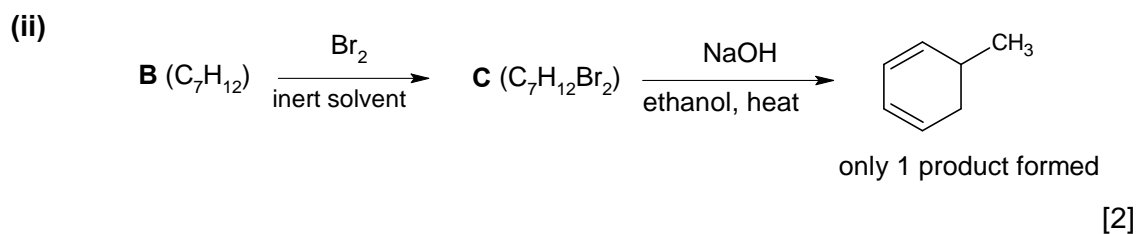
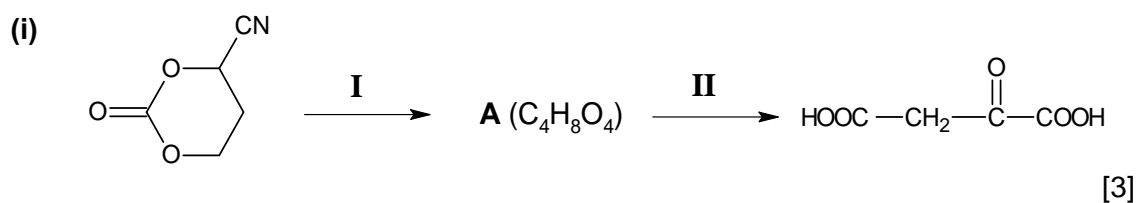

[Total: 21]

- 2 (a) Ethiopia is severely impacted by inadequate safe drinking water, where halogen contaminants such as chloride in drinking water, are the root cause of many common ailments such as low immunity and hypertension.

The Mohr's method is used to determine the chloride ion concentration of water samples from various sources such as seawater and stream.

A researcher retrieved a water sample from a stream and carried out Mohr's method, where the chloride ions present in the water sample is titrated against aqueous silver nitrate solution. As the aqueous silver nitrate is slowly added, a sparingly soluble white precipitate is formed. The indicator used in the titration is aqueous potassium chromate(VI), K_2CrO_4 . The end-point of the titration is reached when any excess silver nitrate added results in the formation of a red-brown precipitate of Ag_2CrO_4 .

The following are relevant K_{sp} values at 298 K:

silver salt	solubility product, K_{sp}
$AgCl$	2.00×10^{-10}
Ag_2CrO_4	1.10×10^{-12}

- (i) Determine the concentration of $Cl^-(aq)$ ions at the end-point of the titration. [1]
- (ii) Explain, with the aid of relevant equations, what would be observed if excess aqueous ammonia is added to the reaction mixture containing the white precipitate. [2]
- (iii) Determine the minimum concentration of $CrO_4^{2-}(aq)$ ions in the titration mixture that is required to precipitate Ag_2CrO_4 immediately after the end-point. [2]
- (b) Oxygen gas, O_2 , reacts with various period 3 elements to produce compounds for numerous uses. For example, aluminium oxide, Al_2O_3 , is often used as a refractory material.

Element **X** forms a white oxide that is soluble in cold water. Its chloride dissolves in water to give a neutral solution.

Element **Y** forms an oxide which has the shape of trigonal planar around the central atom.

1 mole of the oxide of element **X** is added to an aqueous solution containing the same amount of the oxide of element **Y** to form a neutral solution.

Given that **X** and **Y** are period 3 elements, identify element **X** and the oxide of element **Y**. Give an equation to show the formation of the neutral solution. [2]

- (c) Reduction of ozone, O_3 , produces the ozonide anion, O_3^- . Derivatives of this anion are explosive and must be stored at very low temperatures.

Potassium hydroxide reacts with ozone to produce the corresponding metal ozonide, oxygen gas and water.

- (i) Suggest an equation for the reaction between potassium hydroxide and ozone. [1]
- (ii) Draw a dot-and-cross diagram for ozone. Using VSEPR theory, explain the shape and bond angle of ozone. [3]
- (iii) All the O–O bonds in ozone are found to have identical bond lengths. Suggest an explanation for this observation. [1]

- (d) Hydrogen reacts with nitrogen monoxide to give nitrogen and steam as shown.

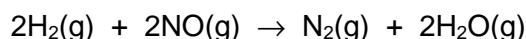

In order to determine the rate equation for this reaction, an investigation was carried out at a constant temperature and with the same concentration of NO for each experiment. The following results were obtained.

experiment	initial $[\text{H}_2]$ / mol dm ⁻³	initial rate of production of N_2 / mol dm ⁻³ s ⁻¹
1	1×10^{-3}	3×10^{-3}
2	2×10^{-3}	6×10^{-3}
3	3×10^{-3}	9×10^{-3}

- (i) Using the above data, deduce the order of reaction with respect to $[\text{H}_2]$. Hence sketch a graph of initial rate against $[\text{H}_2]$. [2]

- (ii) The concentration of NO was halved and a new series of experiments were carried out at the same temperature. When a similar graph was plotted, the magnitude of the gradient decreases by 4 times compared to that obtained from the graph in (d)(i).

Deduce the order of reaction with respect to $[\text{NO}]$.

[1]

- (iii) Hence write the rate equation for the reaction between H_2 and NO. Include the units for the rate constant. [1]

- (iv) The following mechanism was proposed for the reaction of hydrogen with nitrogen monoxide.

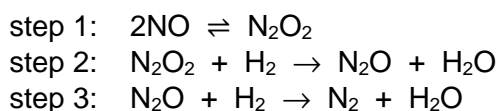

Identify the slow step which is consistent with the rate equation in (d)(iii).

[1]

- (v) Assuming that the reaction in (d) is exothermic, sketch a labelled energy profile diagram for the proposed mechanism in (d)(iv). Indicate clearly the activation energy for each step. [3]

[Total: 20]

3 (a) The protein, somatostatin has been used mainly for its anti-secretory effects in gastrointestinal disorders. Recently, its effects in the treatment of cancer have also been reported.

(i) Complete hydrolysis of a protein produces individual amino acids, but partial hydrolysis can break the protein down into dipeptide or tripeptide fragments.

State the reagents and conditions for the hydrolysis of a somatostatin molecule.

[1]

(ii) A somatostatin polypeptide, containing **fourteen** amino acids, produced the following fragments on hydrolysis.

Ser- Cys
 Phe – Trp – Lys
 Cys – Lys – Asn
 Ala – Gly – Cys
 Asn – Phe – Phe
 Lys – Thr – Phe
 Phe – Thr – Ser

Using the same 3-letter abbreviations as above, deduce the amino acid sequence of the polypeptide.

[2]

(iii) The complete hydrolysis of somatostatin is found to occur spontaneously at **high temperature**.

Suggest an explanation for this observation, taking into account the thermodynamic considerations of the reaction.

[2]

(b) Organophosphates, like carbon monoxide, are toxic to humans. When ingested, organophosphates inhibit the enzyme acetylcholinesterase, resulting in neuro poisoning. Carbon monoxide, on the other hand, inhibits the protein haemoglobin.

One possible treatment of neuro poisoning includes the use of a solution containing carbamates, with the general formula ROCONR_2 . The carbamate administered can stabilise the enzyme by forming an enzyme–carbamate complex, which stops the organophosphates from binding to the enzyme's active site.

Explain, in terms of ligand strength and the type of reaction occurring, why carbamate can be used to treat neuro poisoning.

[2]

- (c) Glutamic acid is used as a flavour enhancer and is responsible for umami, one of the five basic tastes of human sense of taste. It has the structure of

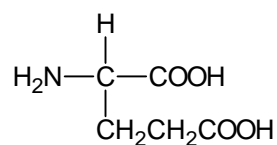

The pK_a values and titration curve of 1 mole of the protonated form of glutamic acid are as shown.

$$pK_{a1} = 2.10$$

$$pK_{a2} = 4.07$$

$$pK_{a3} = 9.47$$

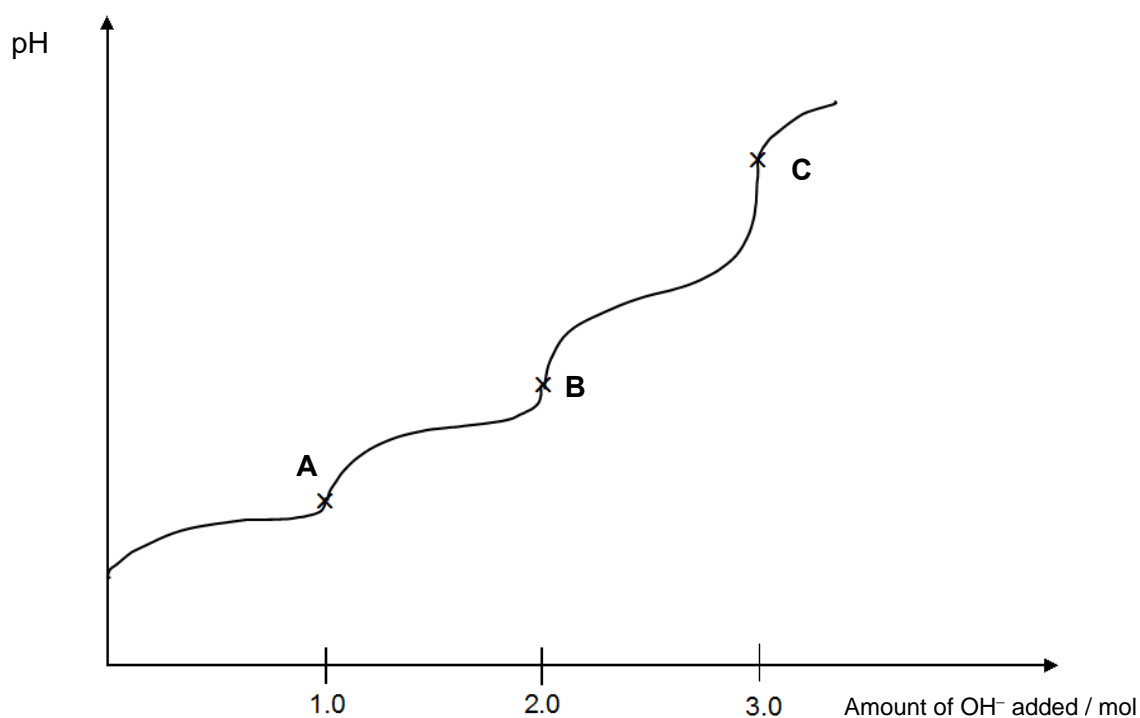

- (i) Suggest the structures of **A**, **B** and **C**. [2]
- (ii) State the pH of the resultant solution when 1.5 moles of OH^- is added to the protonated glutamic acid. [1]

Section B (20 marks)

Answer **one** question from this section on the writing papers provided.

- 4 Organic molecules such as ethyne, C_2H_2 , and ethylenediamine can function as ligands to transition metal ions.

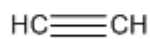

ethyne

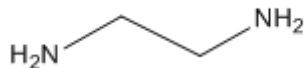

ethylenediamine

- (a) A blue complex salt **A** has the molecular formula $NiN_5H_{17}OCl_2$ ($M_r = 232.7$).
- 1.00 g of **A** reacts completely with 25.00 cm³ of 0.344 mol dm⁻³ silver nitrate solution.
- When excess ethylenediamine was added to the blue solid **A**, a violet solution containing complex **B** was produced. **A** and **B** have the same coordination number.
- (i) Calculate the amount of free chloride ions per mole of **A**. [1]
- (ii) State the full electronic configuration of the nickel ion. Draw fully-labelled diagrams of the orbitals which experience the greatest repulsion between the *d* electrons and the lone pair of electrons on the ligands. [2]
- (iii) With reference to your answer in (a)(i) and (a)(ii), draw a three dimensional diagram to illustrate the shape of the complex ion in **A**. [1]
- (iv) Suggest a possible formula of the complex ion in **B**. [1]
- (b) State the hybridisation of the carbon atoms present in ethyne. Hence, in terms of orbital overlap, justify why ethyne can function as a ligand.



ethyne

[3]

- (c) Alkynes are reduced to alkenes, using the Lindlar's catalyst, which are finely divided palladium metal precipitated onto a calcium carbonate support.

An example is in the synthesis of 7-cis-retinol.

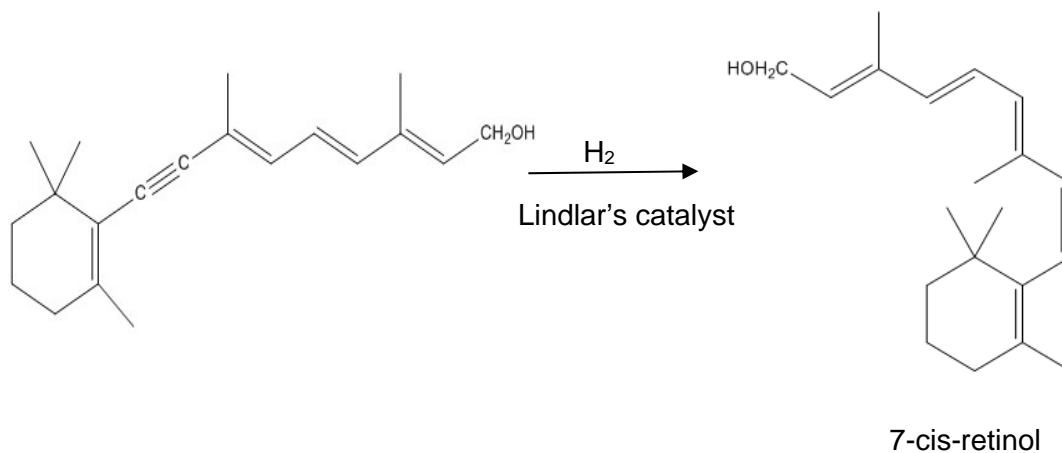

- (i) State the number of cis-trans isomers present in a molecule of 7-cis-retinol. [1]
- (ii) Describe the mode of action by the Lindlar's catalyst. [3]
- (d) Alkyne can also undergo hydration to form an enol which rapidly rearranges itself into a ketone. Such a rearrangement is known as ketone tautomerisation. An example is that of 2,4-pentanedione. [2]

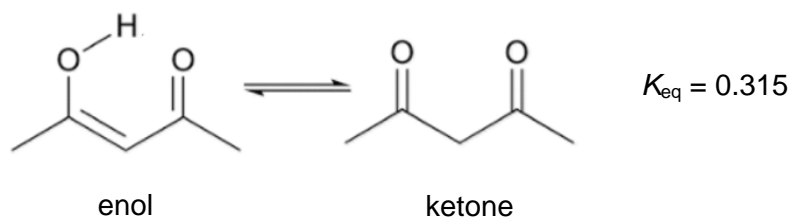

Using the data given, deduce if the tautomerisation reaction is spontaneous.

[2]

- (e) Carbonyl compounds, like 2,4-pentanedione contains acidic α hydrogen atoms.

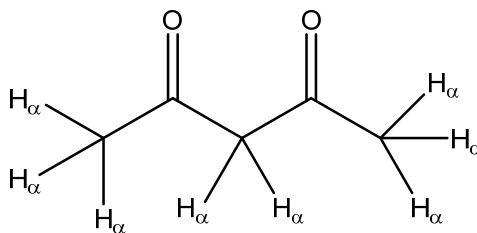

Esters, like ketones and aldehydes, can also contain acidic α hydrogen atoms. When deprotonated by a suitable base, a carbonyl condensation reaction can occur.

An example is the formation of ethyl acetoacetate from ethyl ethanoate.

(Et : $-\text{CH}_2\text{CH}_3$)

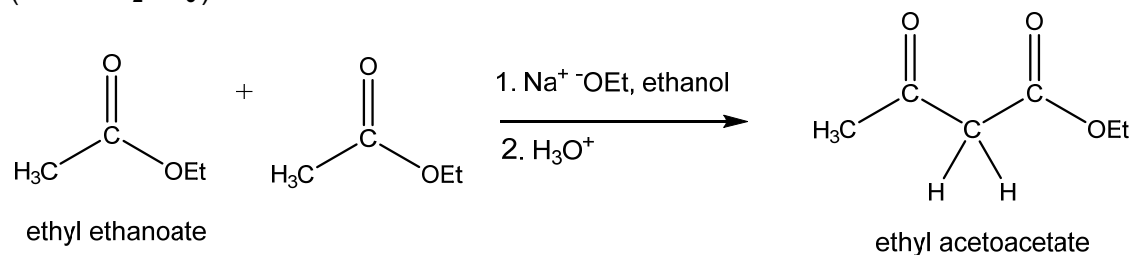

Part of the mechanism is described as follows:

Step 1:

A base, ethoxide ion (^-OEt), abstracts an acidic alpha hydrogen atom from the ethyl ethanoate molecule, yielding a RCH_2^- nucleophile.

Step 2:

The resultant RCH_2^- nucleophile adds to a second ester molecule, giving a tetrahedral alkoxide intermediate:

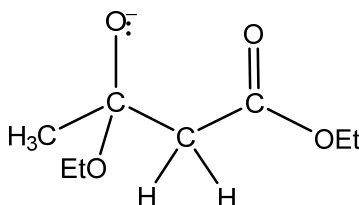

Step 3:

The tetrahedral intermediate expels the ethoxide ion to yield the new carbonyl compound, ethyl acetoacetate.

- (i) Suggest the role of ethanol.

[1]

- (ii) Suggest, with a reason, why the alpha hydrogen of the ester, ethyl ethanoate in Step 1 is acidic.

[1]

- (iii) Using the information given, suggest the mechanism for the reaction. Show relevant lone pairs, dipoles and charges, and indicate the movement of electron pairs with curly arrows.

[3]

- (iv) Compound **X** can be synthesised from diethyl heptanedioate via the carbonyl condensation reaction.

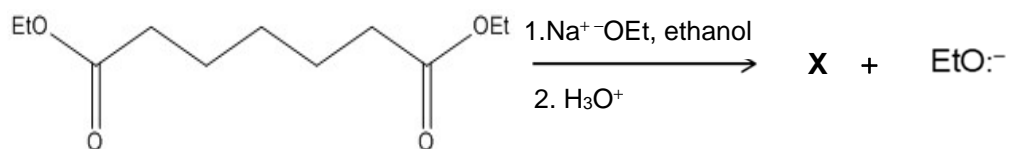

diethyl heptanedioate

Suggest the structure of compound **X**.

[1]

[Total: 20]

- 5 (a) The following shows a series of reactions involving titanium compounds.

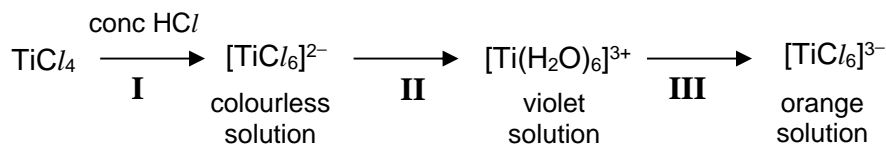

- (i) Suggest the type of reaction for **II** and **III**. [2]
- (ii) Explain why a solution of $[\text{TiCl}_6]^{2-}$ is colourless while that of $[\text{TiCl}_6]^{3-}$ is orange. [2]
- (iii) White light contains all the colours in the visible spectrum, and each of these colours is associated with a certain wavelength λ . The figure below shows a colour wheel with approximate wavelength values in nanometres for different colour light.

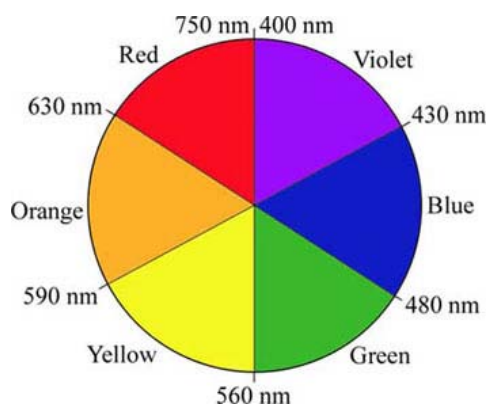

Using the information given and those in (a), deduce whether $[\text{Ti}(\text{H}_2\text{O})_6]^{3+}$ or $[\text{TiCl}_6]^{3-}$ has a bigger energy gap between the d orbitals. [1]

- (iv) Explain why titanium forms complexes with different oxidation states while calcium is unable to do so. [1]

- (b) Organotitanium compounds such as CH_3TiCl_3 can function as nucleophiles. The methyl group, CH_3^- , acts as a nucleophile.

The reduction reaction of an ester, methyl propanoate, $\text{C}_2\text{H}_5\text{COOCH}_3$ with CH_3TiCl_3 , followed by acidification produces a tertiary alcohol, $\text{C}_2\text{H}_5\text{C}(\text{CH}_3)_2\text{OH}$, as shown.



- (i) The mechanism is proposed as follows.

Step 1:

The nucleophile CH_3^- from CH_3TiCl_3 adds to the carbonyl carbon of the ester to form a tetrahedral alkoxide intermediate.

Step 2:

A ketone and a methoxide ion, CH_3O^- are produced from the alkoxide intermediate.

Step 3:

Another CH_3^- from CH_3TiCl_3 adds to the carbonyl carbon of the ketone to form another tetrahedral alkoxide intermediate.

Step 4:

Protonation of the alkoxide intermediate forms the product $\text{C}_2\text{H}_5\text{C}(\text{CH}_3)_2\text{OH}$.

Using the information given, suggest the mechanism for the reaction. Show relevant lone pairs, dipoles and charges, and indicate the movement of electron pairs with curly arrows.

[4]

- (ii) Amides can also be reduced by organotitanium compounds to form the corresponding alcohol and amine. However, this reaction occurs at a slower rate as compared to that of an ester.

Suggest an explanation for this observation.

[1]

- (iii) Suggest a simple chemical test to distinguish between $\text{C}_2\text{H}_5\text{COOCH}_3$ and $\text{C}_2\text{H}_5\text{C}(\text{CH}_3)_2\text{OH}$.

[2]

- (c) The following amino acids are some of the amino acids present in the primary sequence of haemoglobin.

amino acid	formula of side chain (R' in R'CH(NH ₂)CO ₂ H)	isoelectric point
valine	-CH(CH ₃) ₂	6.00
glutamic acid	-CH ₂ CH ₂ COOH	3.15
asparagine	-CH ₂ CONH ₂	5.41

At an intermediate pH, called the isoelectric point (pI), the amino acids will be *zwitterionic* and have *no* net charge.

An electrophoresis experiment is run on a solution containing the above three amino acids at pH 5.00. The relative positions of the amino acids are shown in the diagram below.

The rate at which the amino acids move through the gel is inversely proportional to its mass.

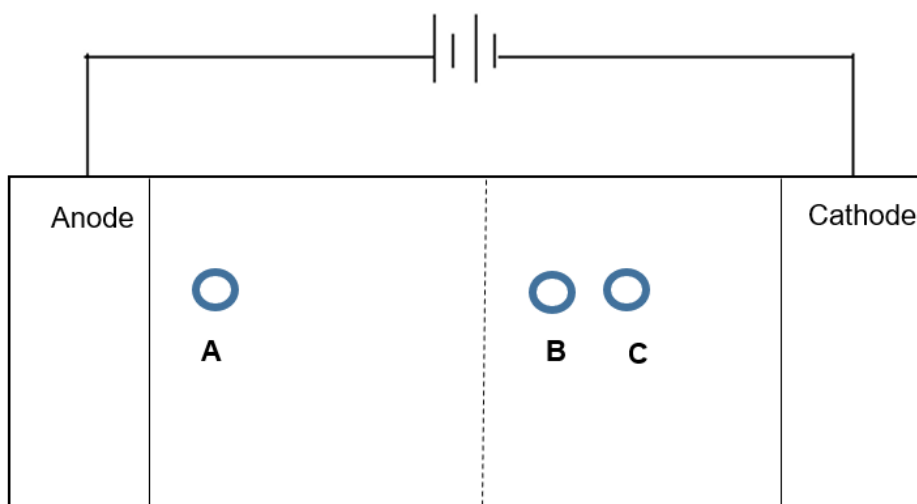

Original position of sample

Identify the structures **A**, **B** and **C**. Hence, explain the position of **B** relative to **C**.

[2]

- (d) Soy beans, and especially the dofu made from them, are a good source of dietary isoflavenoids, which are claimed to help in the prevention of some cancers. The major isoflavenoid in soy is diadzein.

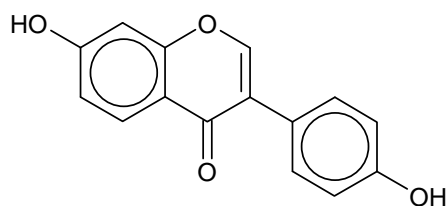

diadzein

When diadzein is treated with H_2 and Ni, compound **D**, $\text{C}_{15}\text{H}_{14}\text{O}_4$, is formed. One mole of compound **D** reacts with three moles of sodium metal. **D** also dissolves in $\text{NaOH}(\text{aq})$. **D** reacts with acidified $\text{K}_2\text{Cr}_2\text{O}_7$ to give compound **E**, $\text{C}_{15}\text{H}_{12}\text{O}_4$, which gives an orange precipitate with 2,4-dinitrophenylhydrazine reagent.

Suggest a structural formula for **D** and for **E**, identifying any chiral carbon atoms. Explain the reactions which occur.

[5]

[Total: 20]

END OF PAPER

Section A (60 marks)

Answer **all** the questions in this section on the writing papers provided.

- 1 (a) A student designed an ion-specific probe to determine the concentration of H^+ ions in solution. He connected a hydrogen electrode to a calomel reference electrode, which comprises a paste of mercury(I) chloride, Hg_2Cl_2 , and mercury in a saturated chloride electrolyte. The reference electrode is inserted into a glass tube with a porous base.

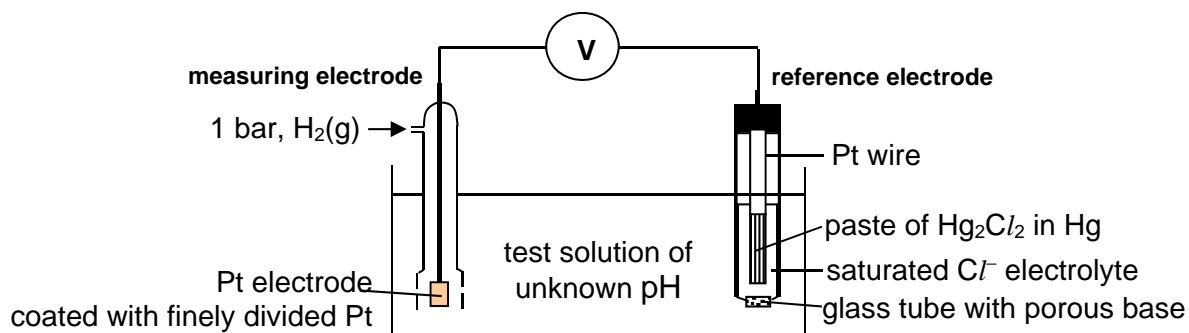

The hydrogen electrode, which is sensitive to H^+ ion concentration, is the measuring electrode. Therefore, this galvanic cell acts as a pH meter.

When both electrodes are in contact with the test solution, an electric current flows through the wire and mercury(I) chloride reacts to form liquid mercury and chloride ion at the reference electrode.

Under standard conditions, the $E^{\ominus}_{\text{cell}}$ of the pH meter is +0.28 V.

- (i) Suggest the use of the glass tube with a porous base in this experimental set-up. [1]

To act as a salt bridge.

- (ii) Identify the half-cell containing the anode. [1]

The half-cell with the hydrogen electrode contains the anode.

In the half-cell containing the calomel reference electrode, Hg^+ undergoes reduction to form Hg. Hence it contains the cathode.

- (iii) Construct the half equation for the reaction occurring at the reference electrode. [1]

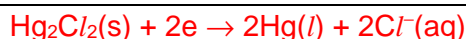

- (iv) Hence write an overall balanced equation for the pH meter. [1]

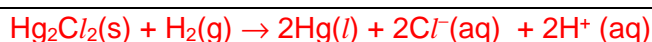

- (v) Determine the ΔG^\ominus of this reaction and state the units.

[2]

$$\Delta G^\ominus = -nFE_{\text{cell}}^\ominus$$

$$\Delta G = -(2)(96500)(+0.28) = -54000 \text{ J mol}^{-1} \text{ or } -54.0 \text{ kJ mol}^{-1}$$

- (vi) Explain why the cell potential would increase when the pH meter is placed in a solution of a higher pH.

[1]

At a higher pH, there is lower $[\text{H}^+]$,

- equilibrium position in $2\text{H}^+(\text{aq}) + 2\text{e} \rightleftharpoons \text{H}_2(\text{g})$ shifts to the left (OR eqm shifts to favour oxidation of H_2) and thus
- $E(\text{H}^+/\text{H}_2)$ becomes (more) negative.

Thus E_{cell} becomes more positive.

- (b) The student used his probe in (a) to analyse a sample of mandelic acid, a bitter almond extract that is used as an antibacterial treatment.

The student obtained a cell potential reading, E_{cell} , of +0.41 V.

The *Nernst equation* can be used to calculate the concentration of H^+ ions detected by the probe:

$$E_{\text{cell}} = E_{\text{cell}}^\ominus - \frac{0.0592}{n} \log_{10} \left(\frac{[\text{H}^+]^2 [\text{Cl}^-]^2}{P_{\text{H}_2}} \right)$$

where n is the number of moles of electrons transferred in the overall reaction,
 $[\text{H}^+]$ is the concentration of hydrogen ions detected,
 $[\text{Cl}^-]$ is the concentration of Cl^- ions,
 P_{H_2} is the pressure, in bar, of hydrogen gas passed into the probe.

Assuming that the concentration of Cl^- is constant at 1 mol dm^{-3} , use the *Nernst equation* to calculate the concentration of H^+ ions in the solution and the pH of the solution.

[2]

$$E = E_{\text{cell}}^\ominus - \frac{0.0592}{n} \log \left(\frac{[\text{H}^+]^2 [\text{Cl}^-]^2}{P_{\text{H}_2}} \right)$$

$$0.41 = 0.28 - \frac{0.0592}{2} \log([\text{H}^+]^2)$$

$$0.41 = 0.28 - \frac{0.0592}{2} \times 2 \log[\text{H}^+]$$

$$\log[\text{H}^+] = -\frac{0.13}{0.0592}$$

$$[\text{H}^+] = 6.37 \times 10^{-3} \text{ mol dm}^{-3}$$

$$\text{pH} = -\log(6.37 \times 10^{-3}) = 2.20$$

(c) A current is passed through three cells connected in series as shown below.

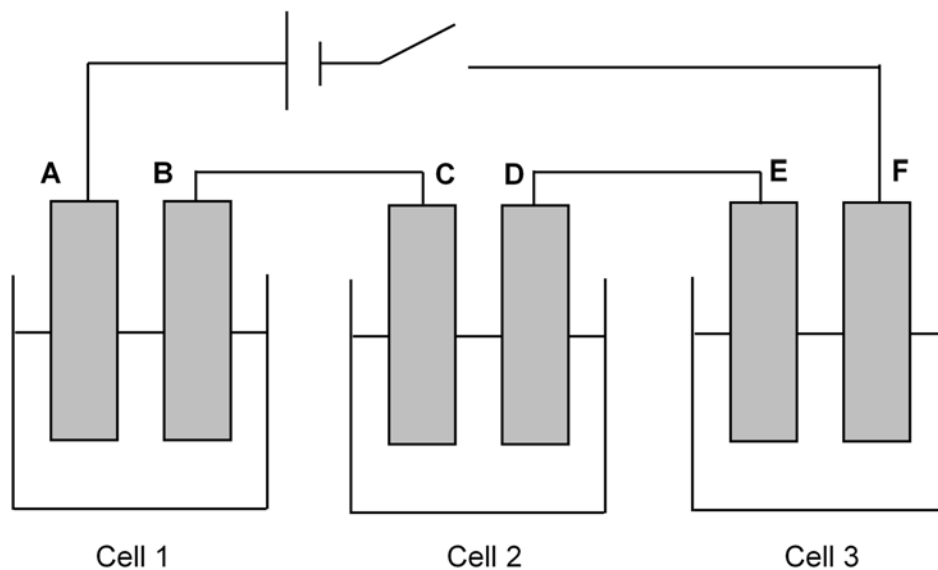

Cell 1 contains lead electrodes, **A**, **B** and electrolyte $\text{Pb}(\text{NO}_3)_2(\text{aq})$.

Cell 2 contains platinum electrodes, **C**, **D** and electrolyte $\text{NaBr}(\text{aq})$.

Cell 3 contains platinum electrodes, **E**, **F** and electrolyte containing $\text{MnCl}_x(\text{aq})$.

- (i) On closing the switch, write equations, including state symbols, for the reactions occurring at electrodes **A** and **D**.

[2]



- (ii) A current of 0.36 A was passed through the circuit for 30 minutes. 0.183 g of manganese was deposited in Cell 3. Determine the value of x in MnCl_x .

[3]

$$Q = 0.36 \times 30 \times 60 = 648\text{C}$$

$$\text{Amount of electrons transferred} = 648/96500 = 0.0067150 \text{ mol}$$

$$\text{Amount of Mn deposited} = 0.183/54.9 = 0.0033333 \text{ mol}$$



$$\frac{n_e}{n_{\text{Mn}}} = \frac{0.0067150}{0.0033333} = 2$$

$$x=2$$

- (d) Identify the structures of compounds **A**, **B**, **C** and **D** and suggest the reagents and conditions for each numbered steps **I**, **II** and **III** where possible.

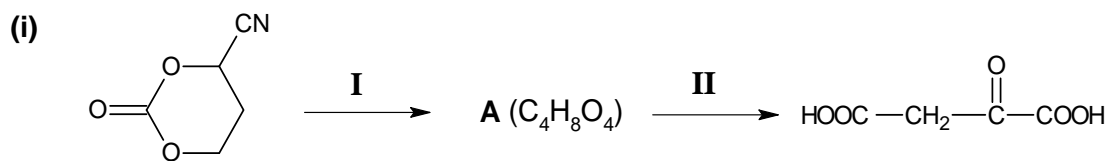

[3]

I: aqueous H_2SO_4 , heat

II: KMnO_4 (or $\text{K}_2\text{Cr}_2\text{O}_7$), aqueous H_2SO_4 , heat

A: $\text{HOCH}_2\text{CH}_2\text{CHOH}(\text{COOH})$

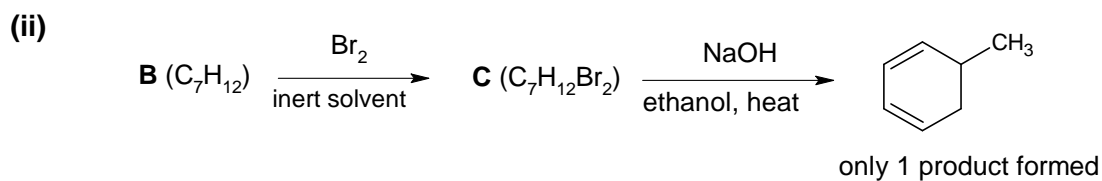

[2]

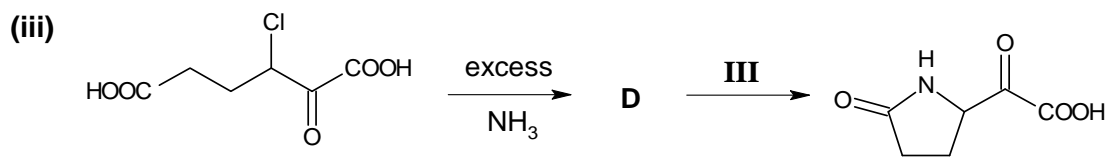
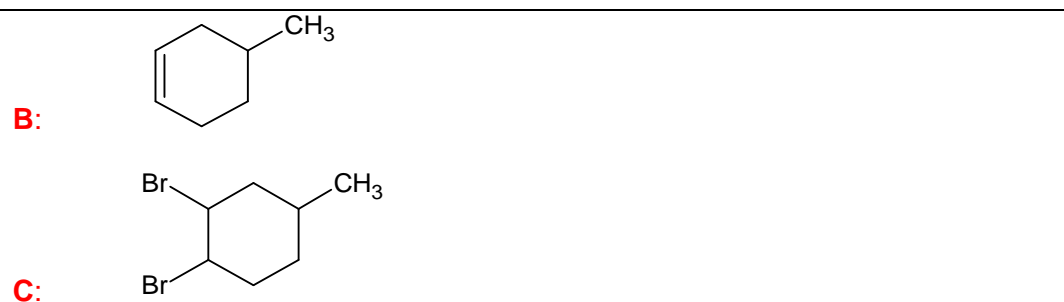

[2]

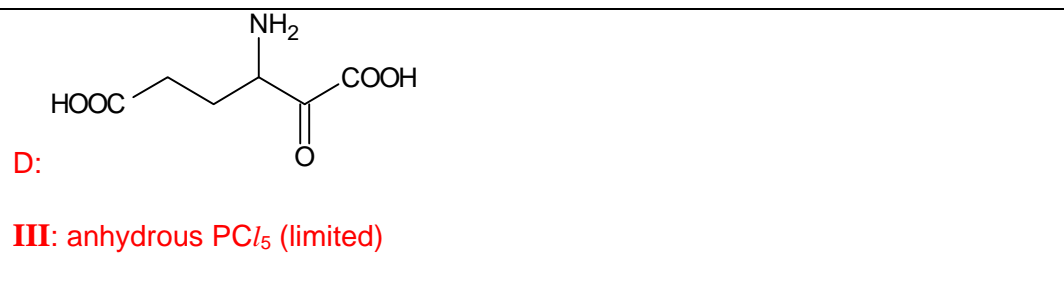

[Total: 21]

- 2 (a) Ethiopia is severely impacted by inadequate safe drinking water, where halogen contaminants such as chloride in drinking water, are the root cause of many common ailments such as low immunity and hypertension.

The Mohr's method is used to determine the chloride ion concentration of water samples from various sources such as seawater and stream.

A researcher retrieved a water sample from a stream and carried out Mohr's method, where the chloride ions present in the water sample is titrated against aqueous silver nitrate solution. As the aqueous silver nitrate is slowly added, a sparingly soluble white precipitate is formed. The indicator used in the titration is aqueous potassium chromate(VI), K_2CrO_4 . The end-point of the titration is reached when any excess silver nitrate added results in the formation of a red-brown precipitate of Ag_2CrO_4 .

The following are relevant K_{sp} values at 298 K:

silver salt	solubility product, K_{sp}
$AgCl$	2.00×10^{-10}
Ag_2CrO_4	1.10×10^{-12}

- (i) Determine the concentration of Cl^- (aq) ions at the end-point of the titration. [1]

At the end point, all the Cl^- in the solution would be precipitated out as $AgCl$.

Let x be the solubility of $AgCl$.

$$K_{sp} = [Ag^+][Cl^-]$$

$$2.00 \times 10^{-10} = x^2$$

$$x = 1.41 \times 10^{-5} \text{ mol dm}^{-3}$$

- (ii) Explain, with the aid of relevant equations, what would be observed if excess aqueous ammonia is added to the reaction mixture containing the white precipitate. [2]

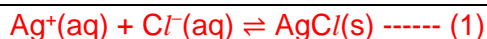

For $AgCl$, when ammonia is added, formation of soluble complex $Ag(NH_3)_2^+$ lowers the concentration of Ag^+ and causes position of equilibrium (1) to shift to the left. The ionic product $[Ag^+][Cl^-] < K_{sp}$ value and hence $AgCl$ dissolves.

- (iii) Determine the minimum concentration of CrO_4^{2-} (aq) ions in the titration mixture that is required to precipitate Ag_2CrO_4 immediately after the end-point. [2]

$$K_{sp} = [Ag^+]^2[CrO_4^{2-}]$$

For precipitation of Ag_2CrO_4 just after end-point, ionic product = K_{sp}

$$(1.41 \times 10^{-5})^2 [CrO_4^{2-}] = 1.10 \times 10^{-12}$$

$$[CrO_4^{2-}] = 5.53 \times 10^{-3} \text{ mol dm}^{-3}$$

- (b) Oxygen gas, O_2 , reacts with various period 3 elements to produce compounds for numerous uses. For example, aluminium oxide, Al_2O_3 , is often used as a refractory material.

Element **X** forms a white oxide that is soluble in cold water. Its chloride dissolves in water to give a neutral solution.

Element **Y** forms an oxide which has the shape of trigonal planar around the central atom.

1 mole of the oxide of element **X** is added to an aqueous solution containing the same amount of the oxide of element **Y** to form a neutral solution.

Given that **X** and **Y** are period 3 elements, identify element **X** and the oxide of element **Y**. Give an equation to show the formation of the neutral solution.

[2]

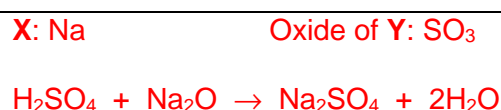

- (c) Reduction of ozone, O_3 , produces the ozonide anion, O_3^- . Derivatives of this anion are explosive and must be stored at very low temperatures.

Potassium hydroxide reacts with ozone to produce the corresponding metal ozonide, oxygen gas and water.

- (i) Suggest an equation for the reaction between potassium hydroxide and ozone.

[1]



Other balanced equations are also acceptable.

- (ii) Draw a dot-and-cross diagram for ozone. Using VSEPR theory, explain the shape and bond angle of ozone.

[3]

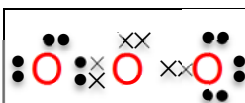

There is 1 lone pair and 2 bond pairs of electrons on the central atom. Electron pairs are arranged as far apart as possible to minimize repulsion Hence it adopts a bent shape.

Repulsion between lone pair-bond pair electrons is greater than the bond pair-bond pair electrons. Hence the bond angle is 117° (or 118°).

- (iii) All the O–O bonds in ozone are found to have identical bond lengths.

Suggest an explanation for this observation.

[1]

The pi electrons are delocalised over the 3 electronegative oxygen atoms.

(Any other phrasing related to resonance is acceptable.)

- (d) Hydrogen reacts with nitrogen monoxide to give nitrogen and steam as shown.

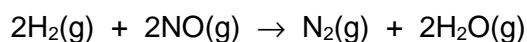

In order to determine the rate equation for this reaction, an investigation was carried out at a constant temperature and with the same concentration of NO for each experiment. The following results were obtained.

experiment	initial $[\text{H}_2]$ / mol dm ⁻³	initial rate of production of N_2 / mol dm ⁻³ s ⁻¹
1	1×10^{-3}	3×10^{-3}
2	2×10^{-3}	6×10^{-3}
3	3×10^{-3}	9×10^{-3}

- (i) Using the above data, deduce the order of reaction with respect to $[\text{H}_2]$. Hence sketch a graph of initial rate against $[\text{H}_2]$.

[2]

Let the rate equation be rate = $k [\text{H}_2]^x [\text{NO}]^y$

Comparing experiment 1 and 2,

$$\left(\frac{1 \times 10^{-3}}{2 \times 10^{-3}}\right)^x = \left(\frac{3 \times 10^{-3}}{6 \times 10^{-3}}\right)$$

$$x = 1$$

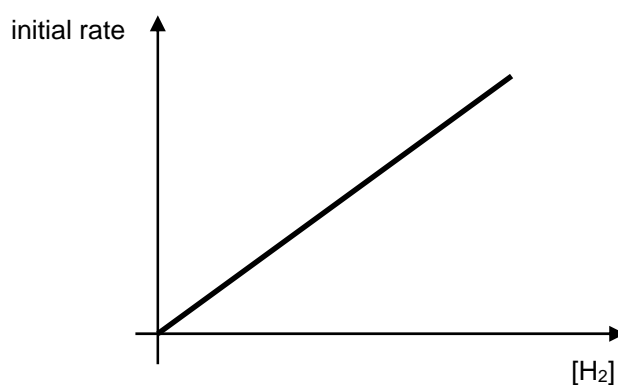

- (ii) The concentration of NO was halved and a new series of experiments were carried out at the same temperature. When a similar graph was plotted, the magnitude of the gradient decreases by 4 times compared to that obtained from the graph in (d)(i).

Deduce the order of reaction with respect to [NO].

[1]

When [NO] decreases by 2 times, rate decreases by 4 times.

Hence order of reaction wrt [NO] is 2.

- (iii) Hence write the rate equation for the reaction between H₂ and NO. Include the units for the rate constant.

[1]

rate = $k [\text{NO}]^2 [\text{H}_2]$

units of $k = \text{mol}^{-2} \text{dm}^6 \text{s}^{-1}$

- (iv) The following mechanism was proposed for the reaction of hydrogen with nitrogen monoxide.

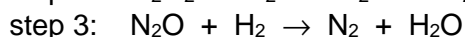
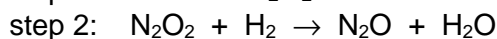

Identify the slow step which is consistent with the rate equation in (d)(iii).

[1]

The second step is the slow step.

- (v) Assuming that the reaction in (d) is exothermic, sketch a labelled energy profile diagram for the proposed mechanism in (d)(iv). Indicate clearly the activation energy for each step.

[3]

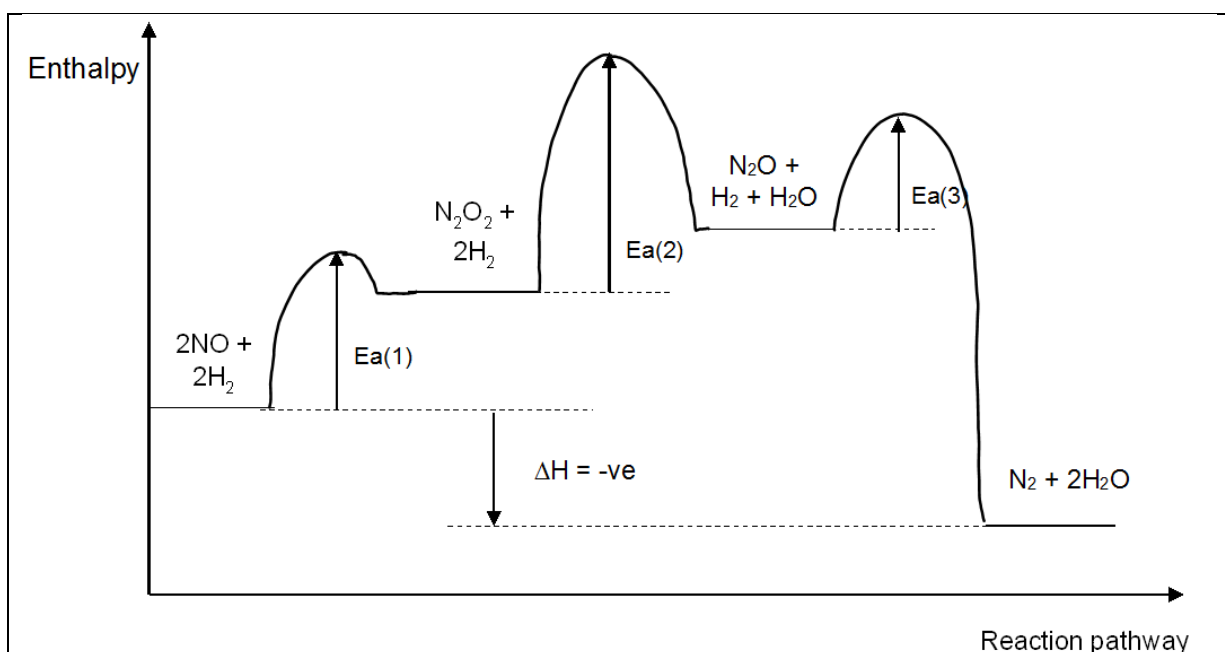

- ✓ Axes correctly labelled
- ✓ 3 humps
- ✓ Ea(2) highest hump
- ✓ ΔH correctly shown
- ✓ All correct reactants, intermediates and products

[Total: 20]

3 (a) The protein, somatostatin has been used mainly for its anti-secretory effects in gastrointestinal disorders. Recently, its effects in the treatment of cancer have also been reported.

(i) Complete hydrolysis of a protein produces individual amino acids, but partial hydrolysis can break the protein down into dipeptide or tripeptide fragments.

State the reagents and conditions for the hydrolysis of a somatostatin molecule.

[1]

aqueous H_2SO_4 (or NaOH), heat under reflux

(ii) A somatostatin polypeptide, containing **fourteen** amino acids, produced the following fragments on hydrolysis.

Ser- Cys
 Phe – Trp – Lys
 Cys – Lys – Asn
 Ala – Gly – Cys
 Asn – Phe – Phe
 Lys – Thr – Phe
 Phe – Thr – Ser

Using the same 3-letter abbreviations as above, deduce the amino acid sequence of the polypeptide.

[2]

Ala- Gly –Cys
 Cys – Lys – Asn
 Asn – Phe – Phe
 Phe – Trp – Lys
 Lys – Thr – Phe
 Phe – Thr – Ser
 Ser – Cys

Ala – Gly – Cys – Lys – Asn – Phe – Phe – Trp – Lys – Thr – Phe – Thr – Ser – Cys

- (iii) The complete hydrolysis of somatostatin is found to occur spontaneously at **high temperature**.

Suggest an explanation for this observation, taking into account the thermodynamic considerations of the reaction.

[2]

- Both ΔS and ΔH are positive
- At higher T, $\Delta G < 0$ as $|T\Delta S| > |\Delta H|$

- (b) Organophosphates, like carbon monoxide, are toxic to humans. When ingested, organophosphates inhibit the enzyme acetylcholinesterase, resulting in neuro poisoning. Carbon monoxide, on the other hand, inhibits the protein haemoglobin.

One possible treatment of neuro poisoning includes the use of a solution containing carbamates, with the general formula ROCONR_2 . The carbamate administered can stabilise the enzyme by forming an enzyme–carbamate complex, which stops the organophosphates from binding to the enzyme's active site.

Explain, in terms of ligand strength and the type of reaction occurring, why carbamate can be used to treat neuro poisoning.

[2]

- Carbamate is a stronger ligand than organophosphate.
- It undergoes ligand exchange reaction and binds more strongly via dative bond to the enzyme to form a more stable complex.
- Hence, it stops the organophosphates from binding to the enzyme's active site.

- (c) Glutamic acid is used as a flavour enhancer and is responsible for umami, one of the five basic tastes of human sense of taste. It has the structure of

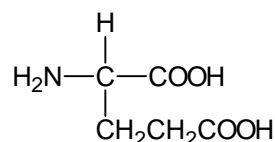

The $\text{p}K_a$ values and titration curve of 1 mole of the protonated form of glutamic acid are as shown.

$$\text{p}K_{a1} = 2.10$$

$$\text{p}K_{a2} = 4.07$$

$$\text{p}K_{a3} = 9.47$$

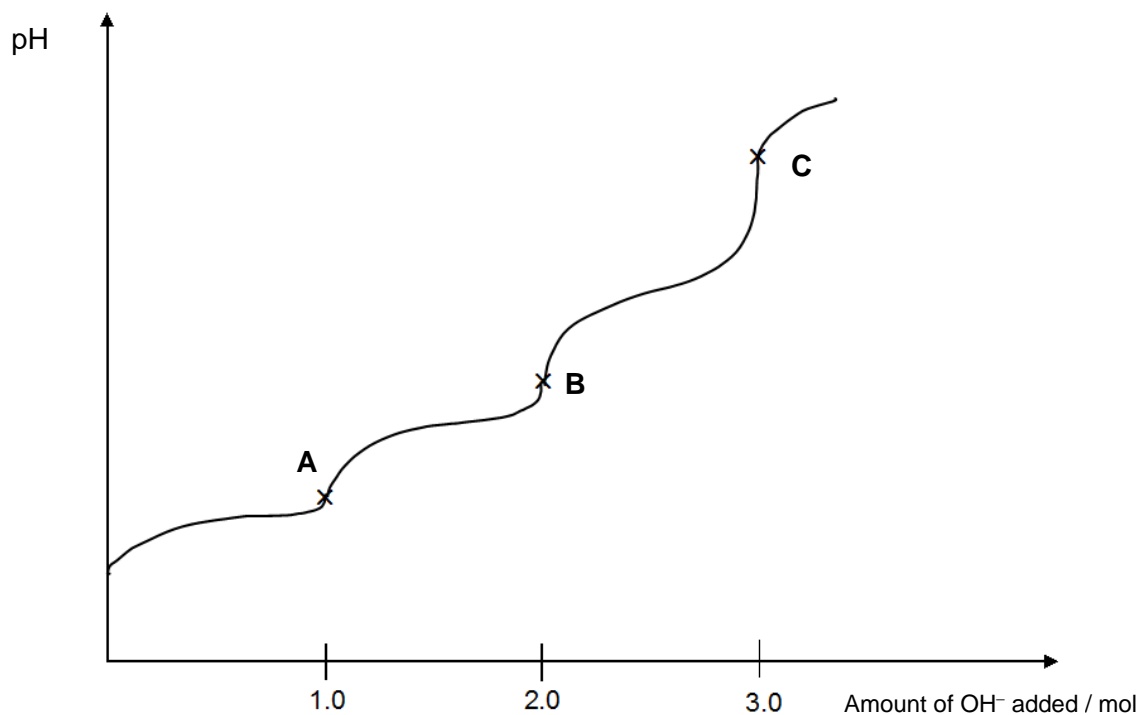

- (i) Suggest the structures of **A**, **B** and **C**.

[2]

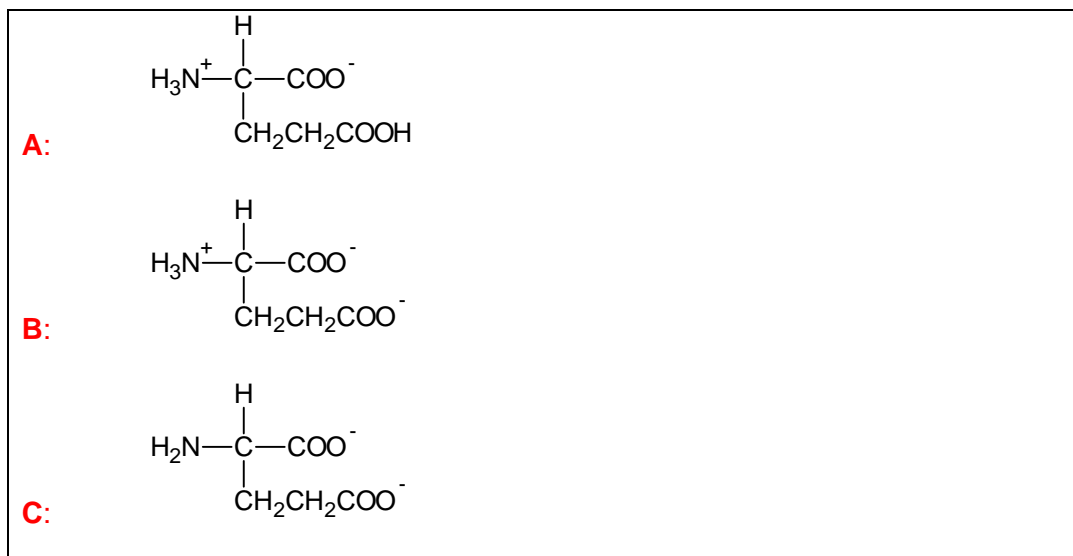

- (ii) State the pH of the resultant solution when 1.5 moles of OH^- is added to the protonated glutamic acid.

[1]

Equimolar quantities of A and B are present.

pH = pK_{a2} = 4.07

- (d) In the Koch reaction, carboxylic acids are formed from the acid catalysed reaction between alkenes and carbon monoxide.

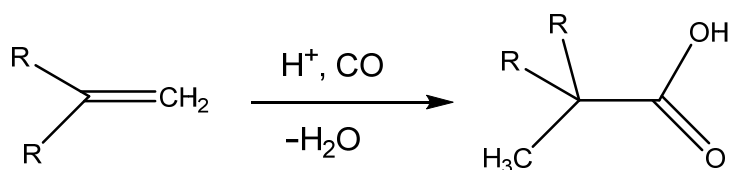

R = alkyl group

- (i) Compound **A** has molecular formula $\text{C}_9\text{H}_{10}\text{O}$. It undergoes the Koch reaction to produce compound **B**.
Compound **A** also decolourises aqueous bromine to produce a white precipitate. When reacted with sodium metal, it produces a gas that extinguishes a lighted splint. It also reacts with acidified potassium manganate (VII), KMnO_4 , to produce compound **C**, $\text{C}_8\text{H}_8\text{O}_2$. When treated with alkaline iodine, compound **C** produces a yellow precipitate. No precipitate was observed when Tollens' reagent was added to compound **C**.

Suggest the structures of compounds **A**, **B** and **C**. Explain all the reactions involved.

[6]

- ✓ High C:H ratio – suggest the presence of an aromatic ring
- ✓ Compound **A** undergoes Koch reaction – suggest presence of a $-\text{C}=\text{C}-$ in compound **A** and a carboxylic acid functional group in compound **B**
- ✓ Compound **A** undergoes **electrophilic substitution** with aqueous bromine to produce a white precipitate – suggest the presence of phenol functional group
- ✓ Compound **A** undergoes **electrophilic addition** with aqueous bromine which gets decolourised – suggest the presence of $-\text{C}=\text{C}-$ functional group
- ✓ Compound **A** undergoes **redox** reaction with $\text{Na}(\text{s})$ to produce hydrogen gas – suggest presence of phenol functional group
- ✓ Compound **A** undergoes **oxidation** with acidified KMnO_4 – suggest presence of an alkene
- ✓ Compound **C** undergoes **oxidation** with alkaline iodine – suggest presence of $-\text{CH}_3\text{CO}$ group
- ✓ Compound **C** **does not** undergo **oxidation** with Tollens' reagent – absence of aldehyde FG /presence of a ketone functional group

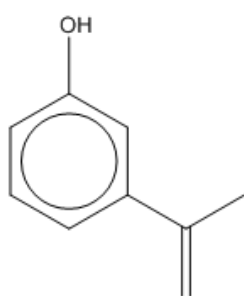

A

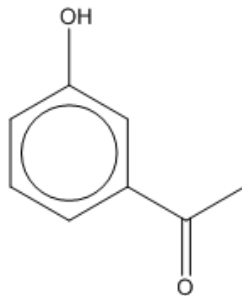

C

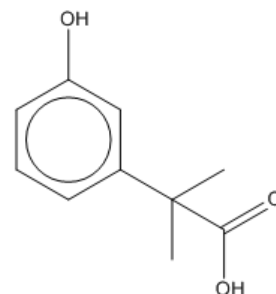

B

$$\frac{\text{Amount of A}}{\text{Amount of Cl}^-} = \frac{4.2974 \times 10^{-3}}{8.60 \times 10^{-3}}$$

$$\approx \frac{1}{2}$$

Hence, 1 mol of A contains **2 mol** of free chloride ions.

- (ii) State the full electronic configuration of the nickel ion. Draw fully-labelled diagrams of the orbitals which experience the greatest repulsion between the *d* electrons and the lone pair of electrons on the ligands.

[2]

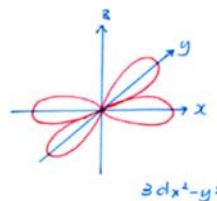
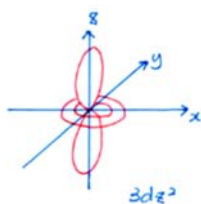
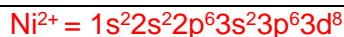

- (iii) With reference to your answer in (a)(i) and (a)(ii), draw a three dimensional diagram to illustrate the shape of the complex ion in A.

[1]

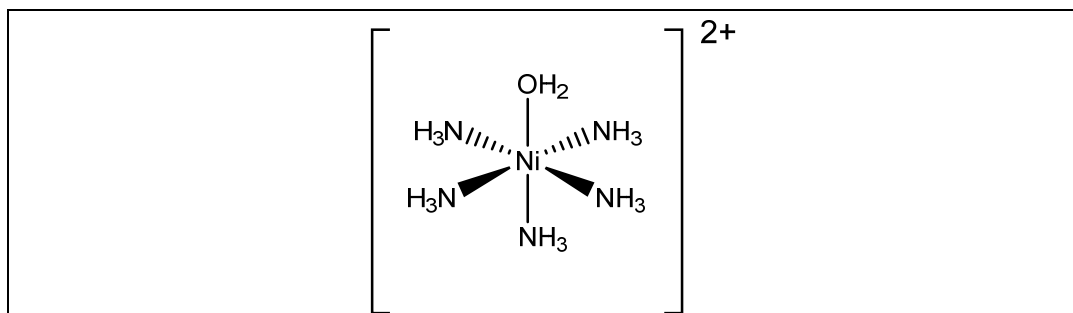

- (iv) Suggest a possible formula of the complex ion in B.

[1]

Any of the following :

- $[\text{Ni}(\text{NH}_2\text{CH}_2\text{CH}_2\text{NH}_2)(\text{NH}_3)_4]^{2+}$
- $[\text{Ni}(\text{NH}_2\text{CH}_2\text{CH}_2\text{NH}_2)(\text{H}_2\text{O})(\text{NH}_3)_3]^{2+}$
- $[\text{Ni}((\text{NH}_2\text{CH}_2\text{CH}_2\text{NH}_2)_2(\text{NH}_3)_2)]^{2+}$
- $[\text{Ni}(\text{NH}_2\text{CH}_2\text{CH}_2\text{NH}_2)_2(\text{H}_2\text{O})(\text{NH}_3)]^{2+}$
- $[\text{Ni}(\text{NH}_2\text{CH}_2\text{CH}_2\text{NH}_2)_3]^{2+}$

- (b) State the hybridisation of the carbon atoms present in ethyne. Hence, in terms of orbital overlap, justify why ethyne can function as a ligand.



ethyne

[3]

1. In ethyne, each of the carbon atom is sp hybridised.
2. The 2 unhybridised p orbital of the two carbon atoms, which is perpendicular to the plane of sp^2 hybrid orbitals, overlaps laterally or sideways to form 2 π bonds.

3. The electron density around the π bond is high, which allows ethyne to function as a ligand (or the pi electrons are not directly involved in holding the 2 carbon nuclei in place and since they are loosely held by the 2 carbon nuclei, they are available for reaction).

- (c) Alkynes are reduced to alkenes, using the Lindlar's catalyst, which are finely divided palladium metal precipitated onto a calcium carbonate support.

An example is in the synthesis of 7-cis-retinol.

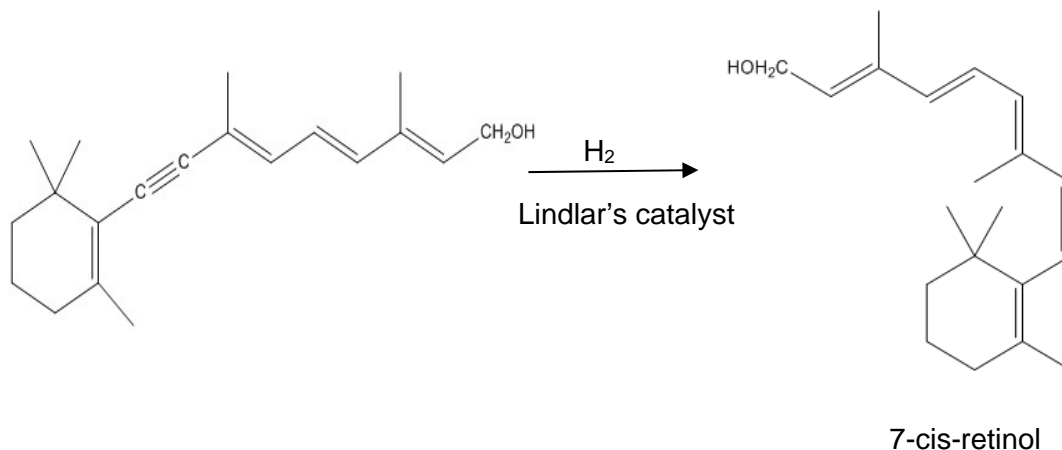

- (i) State the number of cis-trans isomers present in a molecule of 7-cis-retinol. [1]

$$2^4 = 16$$

- (ii) Describe the mode of action by the Lindlar's catalyst. [3]

- ✓ Palladium functions as a heterogeneous catalyst.
- ✓ Availability of partially filled d orbitals in palladium metal allows reactant molecules to adsorb onto metal surface.
- ✓ This weakens the bonds within the reactants.
- ✓ Reactant molecules are also brought closer together, increasing surface concentration on the catalyst.
- ✓ As such, activation energy is lowered.
- ✓ Once the products are formed, the product molecules are desorbed from the metal surface.

- (d) Alkyne can also undergo hydration to form an enol which rapidly rearranges itself into a ketone. Such a rearrangement is known as ketone tautomerisation. An example is that of 2,4-pentanedione.

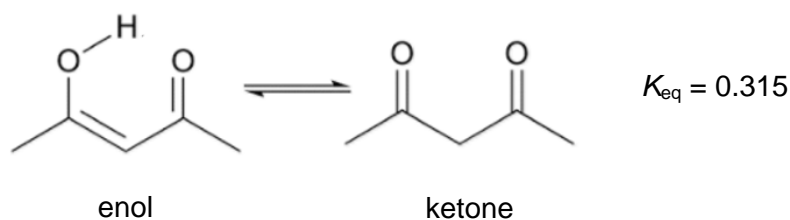

Using the data given, deduce if the tautomerisation reaction is spontaneous.

[2]

$K < 1$, suggest that position of equilibrium lies to the left.
 $\Delta G > 0$, Not spontaneous

- (e) Carbonyl compounds, like 2,4-pentanedione contains acidic α hydrogen atoms.

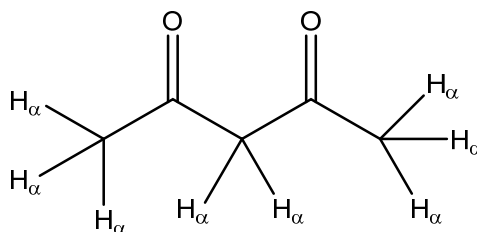

Esters, like ketones and aldehydes, can also contain acidic α hydrogen atoms. When deprotonated by a suitable base, a carbonyl condensation reaction can occur.

An example is the formation of ethyl acetoacetate from ethyl ethanoate.

(Et : $-\text{CH}_2\text{CH}_3$)

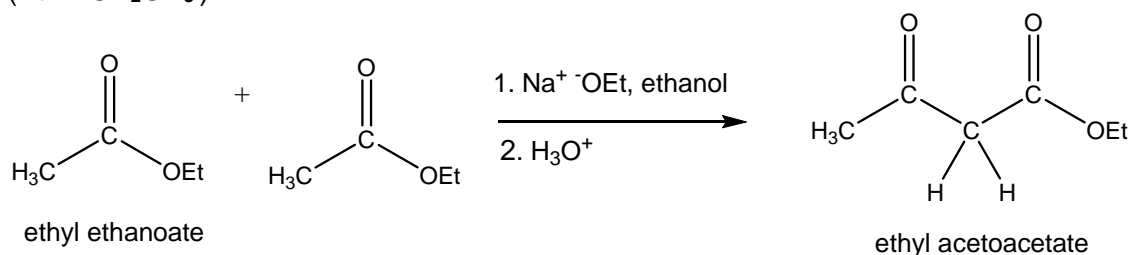

Part of the mechanism is described as follows:

Step 1:

A base, ethoxide ion (^-OEt), abstracts an acidic alpha hydrogen atom from the ethyl ethanoate molecule, yielding a RCH_2^- nucleophile.

Step 2:

The resultant RCH_2^- nucleophile adds to a second ester molecule, giving a tetrahedral alkoxide intermediate:

Step 3:

The tetrahedral intermediate expels the ethoxide ion to yield the new carbonyl compound, ethyl acetoacetate.

(i) Suggest the role of ethanol.

[1]

Organic solvent

(ii) Suggest, with a reason, why the alpha hydrogen of the ester, ethyl ethanoate in Step 1 is acidic.

[1]

The conjugate base produced is stabilised by the electron withdrawing ester functional group (or by resonance)

(iii) Using the information given, suggest the mechanism for the reaction. Show relevant lone pairs, dipoles and charges, and indicate the movement of electron pairs with curly arrows.

[3]

A base, ethoxide ion (^-OEt), abstracts an acidic alpha hydrogen atom from the ethyl ethanoate molecule, yielding a RCH_2^- nucleophile.

+ EtOH

Step 2:

The resultant RCH_2^- nucleophile adds to a second ester molecule, giving a tetrahedral alkoxide intermediate:

Step 3:

The tetrahedral intermediate expels the ethoxide ion to yield the new carbonyl compound, ethyl acetoacetate.

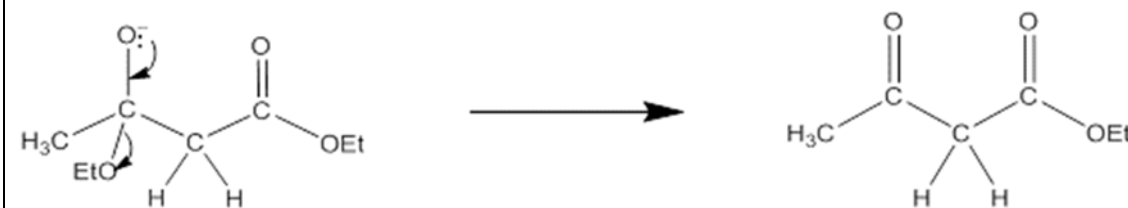

(iv) Compound **X** can be synthesised from diethyl heptanedioate via the carbonyl condensation reaction.

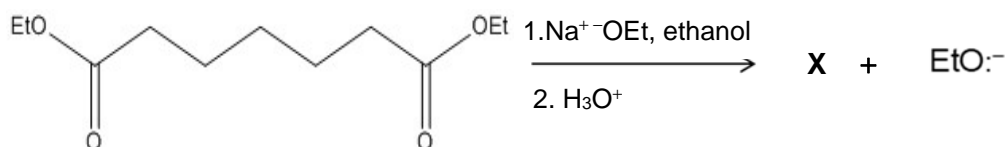

diethyl heptanedioate

Suggest the structure of compound **X**.

[1]

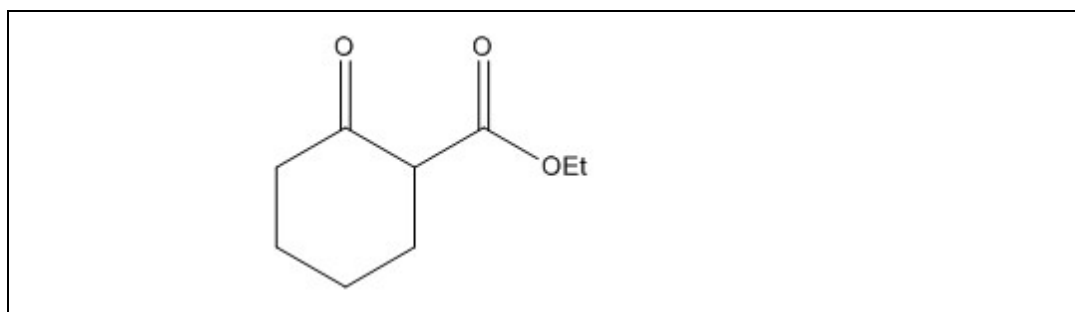

[Total: 20 m]

5 (a) The following shows a series of reactions involving titanium compounds.

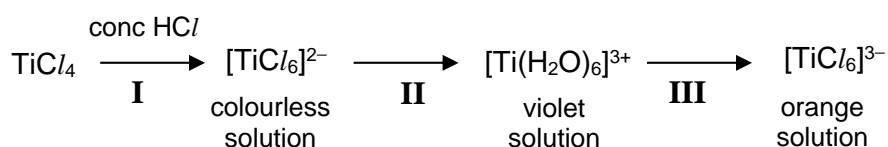

(i) Suggest the type of reaction for **II** and **III**.

[2]

II: reduction or redox

III: ligand exchange

- (ii) Explain why a solution of $[\text{TiCl}_6]^{2-}$ is colourless while that of $[\text{TiCl}_6]^{3-}$ is orange. [2]

Ti^{4+} in $[\text{TiCl}_6]^{2-}$ has empty d orbitals while Ti^{3+} in $[\text{TiCl}_6]^{3-}$ contains partially filled d orbitals.

Hence electron can be promoted from lower energy d orbital to the higher energy d orbital ($d-d$ transition) for $[\text{TiCl}_6]^{3-}$ but not for $[\text{TiCl}_6]^{2-}$.

- (iii) White light contains all the colours in the visible spectrum, and each of these colours is associated with a certain wavelength λ . The figure below shows a colour wheel with approximate wavelength values in nanometres for different colour light.

The formula relating energy gap between d orbitals, ΔE and wavelength λ is given as $\Delta E = \frac{hc}{\lambda}$, where h is the Planck's constant and c is the speed of light. As wavelength decreases, the energy gap increases.

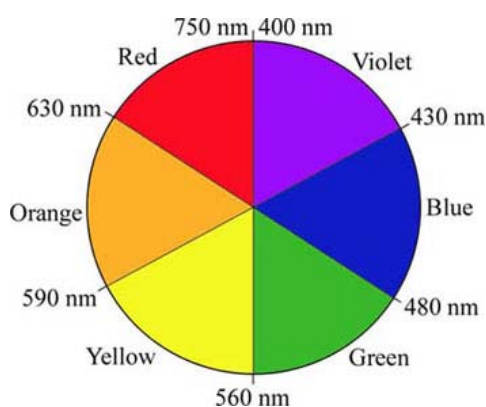

Using the information given and those in (a), deduce whether $[\text{Ti}(\text{H}_2\text{O})_6]^{3+}$ or $[\text{TiCl}_6]^{3-}$ has a bigger energy gap between the d orbitals. [1]

Violet $[\text{Ti}(\text{H}_2\text{O})_6]^{3+}$ absorbs in the yellow region while orange $[\text{TiCl}_6]^{3-}$ absorbs in the blue region. Blue colour has a shorter wavelength than yellow and thus indicates a bigger energy gap between the 2 sets of orbitals.

- (iv) Explain why titanium forms complexes with different oxidation states while calcium is unable to do so. [1]

Ti can show variable oxidation states as the energy difference between the $3d$ and $4s$ orbitals of titanium is relatively small. With sufficient energy, the $4s$ and inner $3d$ electrons can be removed.

- (b) Organotitanium compounds such as CH_3TiCl_3 can function as nucleophiles. The methyl group, CH_3^- , acts as a nucleophile.

The reduction reaction of an ester, methyl propanoate, $\text{C}_2\text{H}_5\text{COOCH}_3$ with CH_3TiCl_3 , followed by acidification produces a tertiary alcohol, $\text{C}_2\text{H}_5\text{C}(\text{CH}_3)_2\text{OH}$, as shown.



- (i) The mechanism is proposed as follows.

Step 1:

The nucleophile CH_3^- from CH_3TiCl_3 adds to the carbonyl carbon of the ester to form a tetrahedral alkoxide intermediate.

Step 2:

A ketone and a methoxide ion, CH_3O^- are produced from the alkoxide intermediate.

Step 3:

Another CH_3^- from CH_3TiCl_3 adds to the carbonyl carbon of the ketone to form another tetrahedral alkoxide intermediate.

Step 4:

Protonation of the alkoxide intermediate forms the product $\text{C}_2\text{H}_5\text{C}(\text{CH}_3)_2\text{OH}$.

Using the information given, suggest the mechanism for the reaction. Show relevant lone pairs, dipoles and charges, and indicate the movement of electron pairs with curly arrows.

[4]

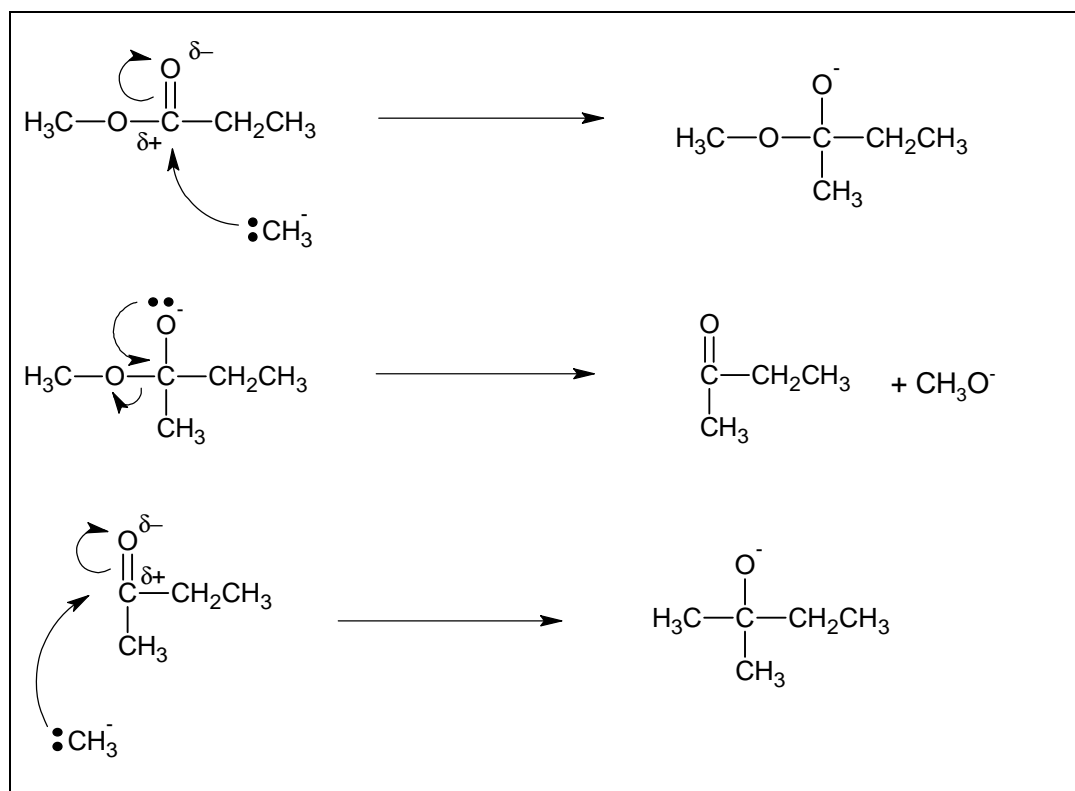

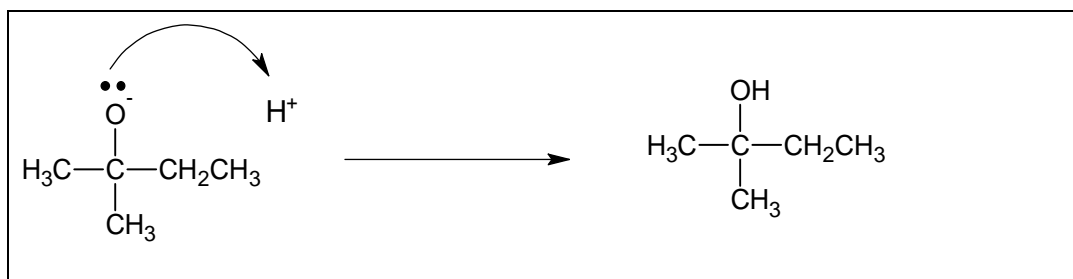

- (ii) Amides can also be reduced by organotitanium compounds to form the corresponding alcohol and amine. However, this reaction occurs at a slower rate as compared to that of an ester.

Suggest an explanation for this observation.

[1]

Oxygen is more electronegative than nitrogen, hence the carbonyl carbon of the ester is more electron deficient compared to that of the amide. Hence the ester is more susceptible to nucleophilic attack by the reducing agent.

- (iii) Suggest a simple chemical test to distinguish between $C_2H_5COOCH_3$ and $C_2H_5C(CH_3)_2OH$.

[2]

test: anhydrous PCl_5

observations: white fumes of HCl observed for $C_2H_5C(CH_3)_2OH$ and no fumes observed for $C_2H_5COOCH_3$

Other alternatives are acceptable eg Na test.

- (c) The following amino acids are some of the amino acids present in the primary sequence of haemoglobin.

amino acid	formula of side chain (R' in $R'CH(NH_2)CO_2H$)	isoelectric point
valine	$-CH(CH_3)_2$	6.00
glutamic acid	$-CH_2CH_2COOH$	3.15
asparagine	$-CH_2CONH_2$	5.41

At an intermediate pH, called the isoelectric point (pI), the amino acids will be *zwitterionic* and have *no* net charge.

An electrophoresis experiment is run on a solution containing the above three amino acids at pH 5.00. The relative positions of the amino acids are shown in the diagram below.

The rate at which the amino acids move through the gel is inversely proportional to its mass.

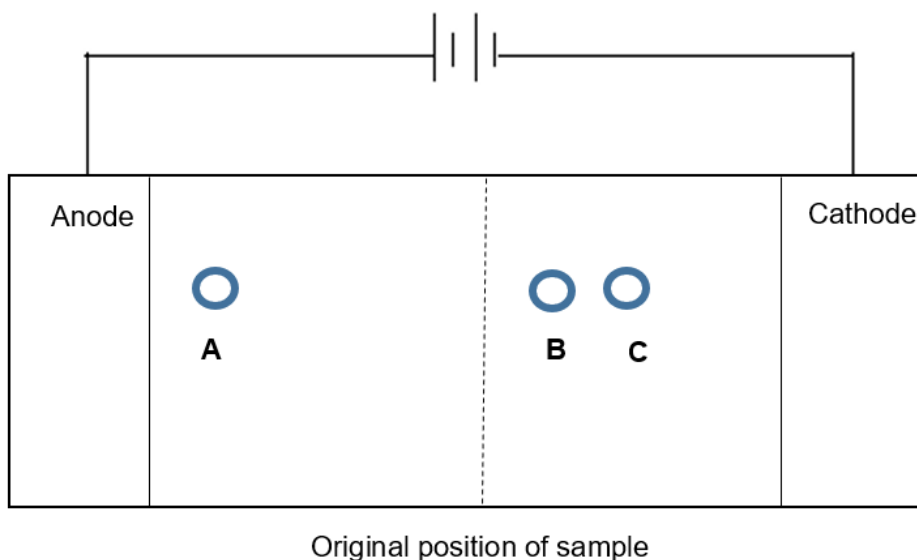

Identify the structures **A**, **B** and **C**. Hence, explain the position of **B** relative to **C**.

[2]

A: Glutamic acid; **B**: Asparagine ; **C** : Valine

Asparagine has a larger molecular mass than valine. Since, the rate in which the amino acids move through the gel is inversely proportional to its mass, asparagine will migrate to the cathode at a slower rate.

- (d) Soy beans, and especially the dofu made from them, are a good source of dietary isoflavenoids, which are claimed to help in the prevention of some cancers. The major isoflavenoid in soy is diadzein.

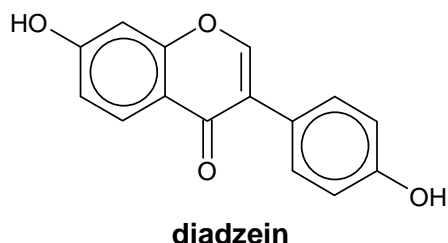

When diadzein is treated with H_2 and Ni , compound **D**, $\text{C}_{15}\text{H}_{14}\text{O}_4$, is formed. One mole of compound **D** reacts with three moles of sodium metal. **D** also dissolves in $\text{NaOH}(\text{aq})$. **D** reacts with acidified $\text{K}_2\text{Cr}_2\text{O}_7$ to give compound **E**, $\text{C}_{15}\text{H}_{12}\text{O}_4$, which gives an orange precipitate with 2,4-dinitrophenylhydrazine reagent.

Suggest a structural formula for **D** and for **E**, identifying any chiral carbon atoms. Explain the reactions which occur.

[5]

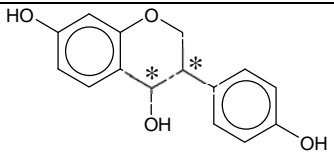
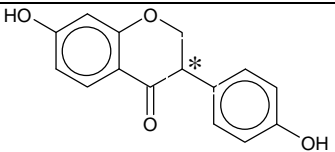
D	E
	

Structures of **D** and **E** with chiral carbon correctly identified

The alkene and ketone in diadzein undergoes reduction with H_2 and Ni to form **D**.

1 mole of **D** undergoes redox with 3 moles of Na as it has 3 $-OH$ groups.

D dissolves in NaOH(aq) as it contains acidic phenol and undergoes acid-base reaction.

The secondary alcohol in **D** is oxidised to ketone.

E contains a ketone group thus it gives an orange precipitate with 2,4-DNPH via condensation reaction.

[Total: 20]

END OF PAPER