

Name:		Centre/Index Number:		Class:	
-------	--	----------------------	--	--------	--



**DUNMAN HIGH SCHOOL**  
**Preliminary Examination**  
**Year 6**

---

**H2 PHYSICS**

Paper 1 Multiple Choice

**9749/01**

**23 September 2022**  
**1 hour**

Additional Materials: Multiple Choice Answer Sheet

---

**READ THESE INSTRUCTIONS FIRST**

Write your centre number, index number, name and class at the top of this page.

Write in soft pencil.

Do not use staples, paper clips, glue or correction fluid.

There are **thirty** questions on this paper. Answer **all** questions. For each question there are four possible answers **A, B, C** and **D**.

Choose the one you consider correct and record your choice in **soft pencil** on the separate Answer Sheet.

**Read the instructions on the Answer Sheet very carefully.**

Each correct answer will score one mark. A mark will not be deducted for a wrong answer. Any rough working should be done in this booklet.

The use of an approved scientific calculator is expected, where appropriate.

---

This document consists of **16** printed pages.

## 2

**Data**

speed of light in free space,	$c = 3.00 \times 10^8 \text{ m s}^{-1}$
permeability of free space,	$\mu_0 = 4\pi \times 10^{-7} \text{ H m}^{-1}$
permittivity of free space,	$\epsilon_0 = 8.85 \times 10^{-12} \text{ F m}^{-1}$ $(1/(36\pi)) \times 10^{-9} \text{ F m}^{-1}$
elementary charge,	$e = 1.60 \times 10^{-19} \text{ C}$
the Planck constant,	$h = 6.63 \times 10^{-34} \text{ J s}$
unified atomic mass constant,	$u = 1.66 \times 10^{-27} \text{ kg}$
rest mass of electron,	$m_e = 9.11 \times 10^{-31} \text{ kg}$
rest mass of proton,	$m_p = 1.67 \times 10^{-27} \text{ kg}$
molar gas constant,	$R = 8.31 \text{ J K}^{-1} \text{ mol}^{-1}$
the Avogadro constant,	$N_A = 6.02 \times 10^{23} \text{ mol}^{-1}$
the Boltzmann constant,	$k = 1.38 \times 10^{-23} \text{ J K}^{-1}$
gravitational constant,	$G = 6.67 \times 10^{-11} \text{ N m}^2 \text{ kg}^{-2}$
acceleration of free fall,	$g = 9.81 \text{ m s}^{-2}$

**Formulae**

uniformly accelerated motion	$s = ut + \frac{1}{2}at^2$
	$v^2 = u^2 + 2as$
work done on/by a gas	$W = p\Delta V$
hydrostatic pressure	$p = \rho gh$
gravitational potential	$\phi = -\frac{Gm}{r}$
temperature	$T/K = T/^{\circ}\text{C} + 273.15$
pressure of an ideal gas	$p = \frac{1}{3} \frac{Nm}{V} \langle c^2 \rangle$
mean translational kinetic energy of an ideal gas molecule	$E = \frac{3}{2}kT$
displacement of particle in s.h.m.	$x = x_0 \sin \omega t$
velocity of particle in s.h.m.	$v = v_0 \cos \omega t$ $= \pm \omega \sqrt{x_0^2 - x^2}$
electric current	$I = Anvq$
resistors in series	$R = R_1 + R_2 + \dots$
resistors in parallel	$1/R = 1/R_1 + 1/R_2 + \dots$
electric potential	$V = \frac{Q}{4\pi\epsilon_0 r}$
alternating current / voltage	$x = x_0 \sin \omega t$
magnetic flux density due to a long straight wire	$B = \frac{\mu_0 I}{2\pi d}$
magnetic flux density due to a flat circular coil	$B = \frac{\mu_0 NI}{2r}$
magnetic flux density due to a long solenoid	$B = \mu_0 nI$
radioactive decay	$x = x_0 \exp(-\lambda t)$
decay constant	$\lambda = \frac{\ln 2}{t_{\frac{1}{2}}}$

## 4

- 1 A computer memory stick is labelled as having a storage capacity of 128 GB.  
The letter B stands for byte, which is a unit.

What is the equivalent storage capacity, in B?

- A  $1.28 \times 10^8$       B  $1.28 \times 10^9$       C  $1.28 \times 10^{10}$       D  $1.28 \times 10^{11}$

- 2 A steel rule can be read to the nearest millimetre. It is used to measure the length of a bar whose true length is 895 mm. Repeated measurements give the following readings.

length / mm	892, 891, 892, 891, 891, 892
-------------	------------------------------

Are the readings accurate and precise to within 1 mm?

	results are accurate to within 1 mm	results are precise to within 1 mm
A	no	yes
B	no	no
C	yes	no
D	yes	yes

- 3 A body having uniform acceleration  $a$  increases its velocity from  $u$  to  $v$  in time  $t$ .  
Which expression would **not** give a correct value for the body's displacement during time  $t$ ?

A  $ut + \frac{1}{2}at^2$

B  $vt - \frac{1}{2}at^2$

C  $\frac{(v+u)(v-u)}{2a}$

D  $\frac{(v-u)t}{2}$

5

- 4 A sphere is released from a tall building and falls.  
Which displacement-time graph best represents the motion of the sphere?

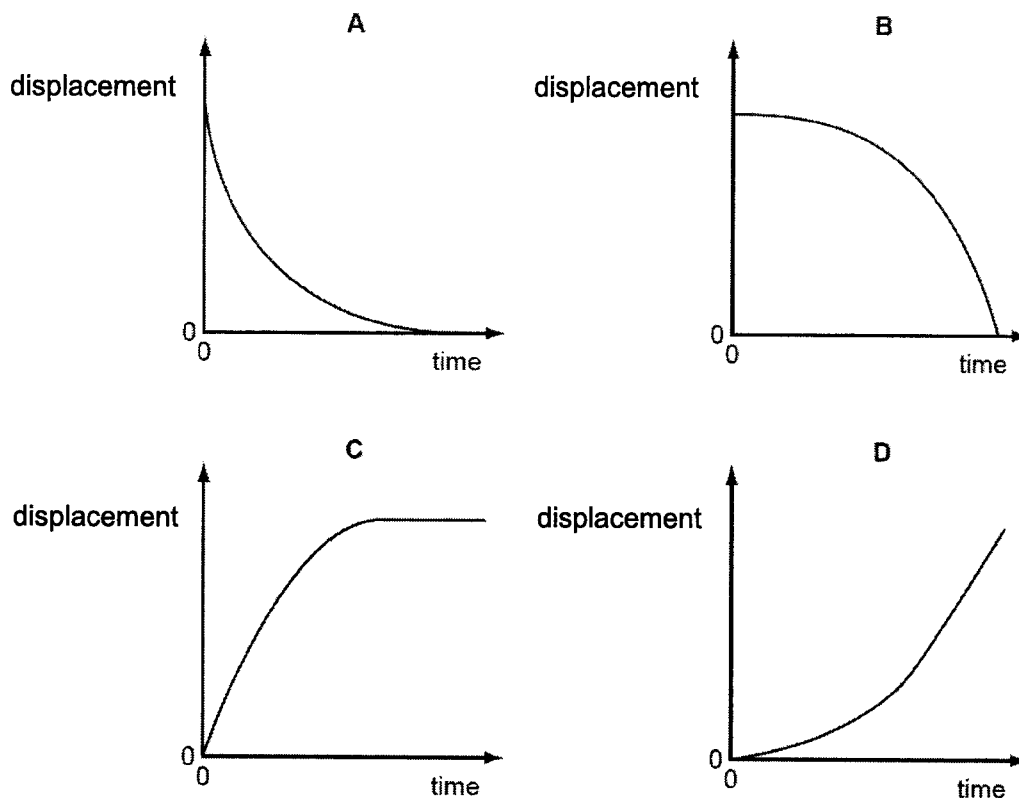

- 5 A book of weight  $W$  is at rest on a table. A student attempts to state Newton's third law by saying that 'action equals reaction'.

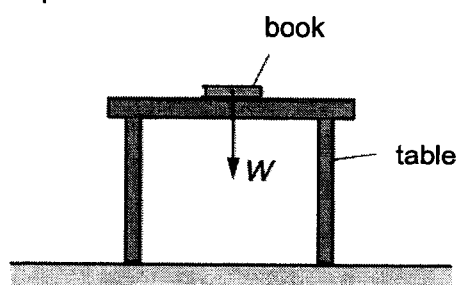

If the weight of the book is the 'action' force, what is the 'reaction' force?

- A The force  $W$  acting downwards on the Earth from the table.
- B The force  $W$  acting upwards on the book from the table.
- C The force  $W$  acting upwards on the Earth from the book.
- D The force  $W$  acting upwards on the table from the floor.

6

- 6 A ball drops onto a horizontal surface and bounces elastically.

What happens to the kinetic energy of the ball during the very short time that it is in contact with the surface?

- A The kinetic energy remains constant because it is an elastic collision.  
 B The kinetic energy remains constant in magnitude but changes direction.  
 C The kinetic energy decreases to zero and then returns to its original value.  
 D Most of the kinetic energy is lost as heat and sound.
- 7 A trailer of weight 30 kN is attached to a cab at X, as shown in the diagram.

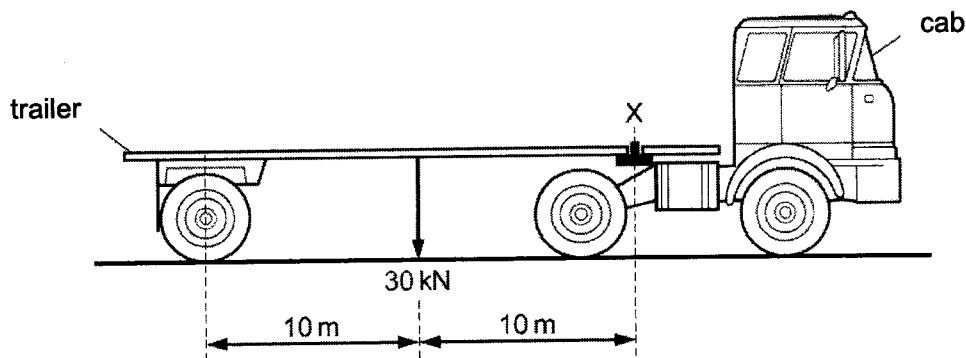

What is the upward force exerted at X by the cab on the trailer?

- A 3 kN                      B 15 kN                      C 30 kN                      D 60 kN
- 8 A solid metal cylinder stands on a horizontal surface, as shown.

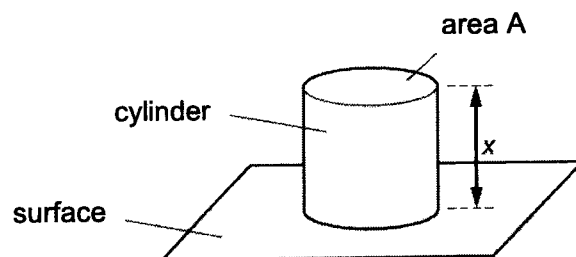

The cylinder has length  $x$  and cross-sectional area  $A$ . The cylinder exerts a pressure  $p$  on the surface. The acceleration of free fall is  $g$ .

Which expression gives the density of the metal of the cylinder?

- A  $\frac{gx}{\rho A}$                       B  $\frac{\rho A}{gx}$                       C  $\frac{gx}{p}$                       D  $\frac{p}{gx}$

- 9 A car of mass 500 kg is at rest at point X on a slope, as shown.

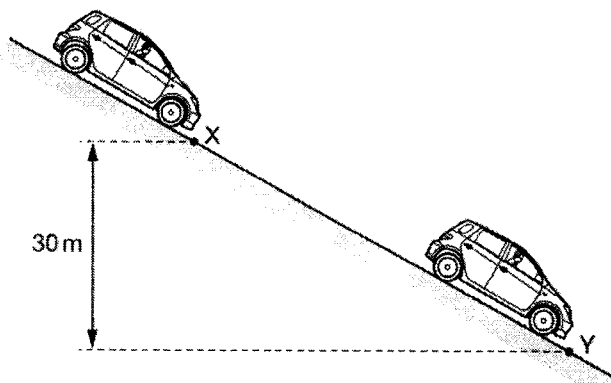

The car's brakes are released, and the car rolls down the slope with its engine switched off. At point Y the car has moved through a vertical height of 30 m and has a speed of  $11 \text{ m s}^{-1}$ .

What is the energy dissipated by frictional forces when the car moves from X to Y?

- A  $3.0 \times 10^4 \text{ J}$       B  $1.2 \times 10^5 \text{ J}$       C  $1.5 \times 10^5 \text{ J}$       D  $1.8 \times 10^5 \text{ J}$
- 10 A water pump is driven by an engine. The pump raises a volume of  $0.50 \text{ m}^3$  of water in 1.0 minute from a depth of 30 m. The pump has an efficiency of 70%.  
The density of water is  $1000 \text{ kg m}^{-3}$ .  
What is the useful output power from the engine?
- A 2.5 kW      B 3.5 kW      C 150 kW      D 210 kW
- 11 Two objects of masses 5.0 kg and 8.0 kg are fixed on a horizontal circular platform 2.0 m and 6.0 m from the centre respectively.  
When the platform is rotated with uniform circular motion, what is the ratio of the net force on the 5.0 kg mass to the 8.0 kg mass?

- A 8:15      B 5:24  
C 15:8      D 24:5

- 12 At a point on the surface of a uniform sphere of diameter  $d$ , the gravitational field strength due to the sphere is  $X$ .

What would be the gravitational field strength on the surface of a uniform sphere of the same density but of diameter  $2d$ ?

- A  $\frac{X}{4}$                       B  $\frac{X}{2}$                       C  $2X$                       D  $4X$

- 13 A communication satellite is in a geostationary orbit at a height of  $3.59 \times 10^7$  m above the equator. The radius of the Earth is  $6.40 \times 10^6$  m.

How fast is the satellite travelling?

- A  $0.490 \text{ km s}^{-1}$               B  $2.60 \text{ km s}^{-1}$               C  $3.08 \text{ km s}^{-1}$               D  $186 \text{ km s}^{-1}$

- 14 The two graphs are for the motion of a body undergoing simple harmonic motion.

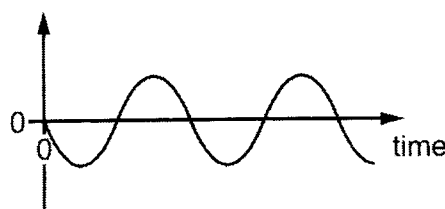
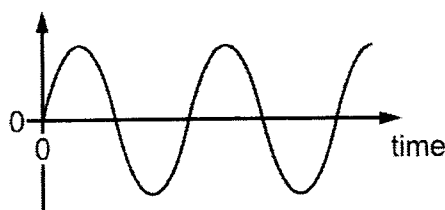

What could the two graphs show?

- A acceleration with time and velocity with time  
 B acceleration with time and displacement with time  
 C displacement with time and velocity with time  
 D resultant force with time and velocity with time
- 15 A small mass on a vibrating platform undergoes simple harmonic motion. The total energy of the mass is 18 mJ.
- The amplitude of the oscillation is now doubled and the time period is tripled.
- What is the new total energy of the mass?
- A 8.0 mJ                      B 12 mJ                      C 36 mJ                      D 72 mJ



- 16 A cathode-ray oscilloscope (CRO) is used to display a wave of frequency 5.0 kHz. The display is shown.

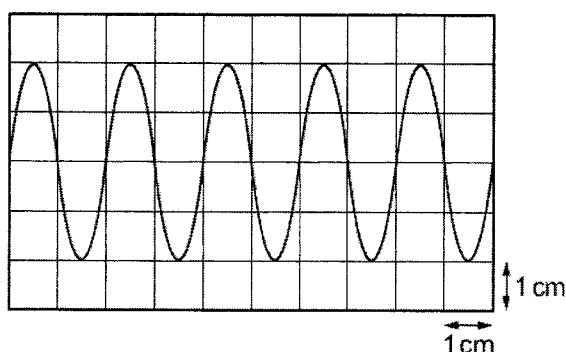

What is the time-base setting of the CRO?

- A  $10 \mu\text{s cm}^{-1}$       B  $100 \mu\text{s cm}^{-1}$       C  $10 \text{ ms cm}^{-1}$       D  $100 \text{ ms cm}^{-1}$
- 17 Two loudspeakers X and Y emit sound waves that are in phase and of wavelength 0.75 m. An observer O is able to stand anywhere on a straight line that passes through X and Y, as shown. The observer stands at a point where the sound waves from X and Y meet in phase.

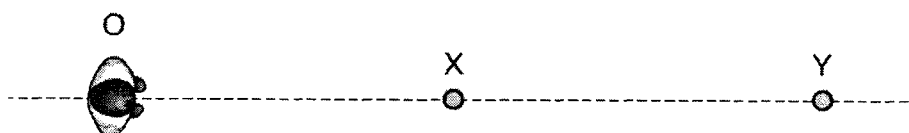

What could be the distances OY and XY?

	distance OY / m	distance XY / m
A	1.25	3.50
B	2.00	2.75
C	2.75	2.00
D	3.25	1.50

- 18 The graph shows the variation in light intensity produced on a screen when a parallel beam of monochromatic light passes through a narrow slit.

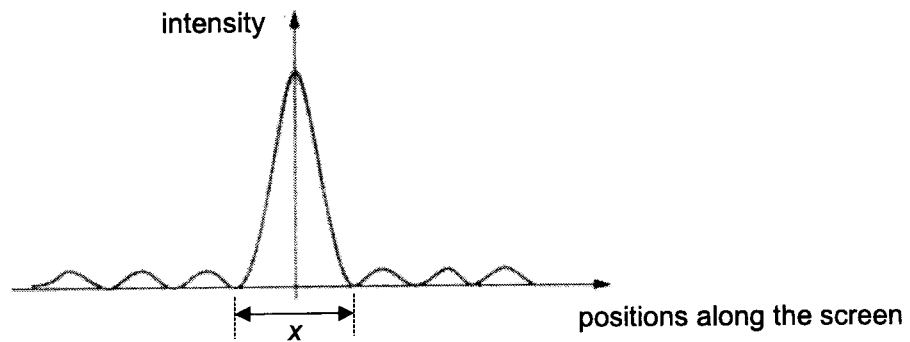

Which of the following statements is incorrect?

- A The area under the graph is unchanged by increasing the slit width.  
 B The width  $x$  is increased by increasing the wavelength of light.  
 C The width  $x$  is increased by increasing the distance between the slit and screen.  
 D The width  $x$  is increased by decreasing the slit width.
- 19 The diagram shows the path of a horizontal beam of electrons passing through the uniform vertical electric field between two horizontal electrodes. The diagram is not to scale.

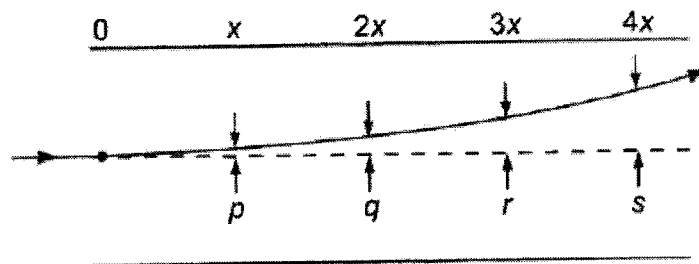

The vertical displacements of the beam after travelling through horizontal distances of  $x$ ,  $2x$ ,  $3x$  and  $4x$  are represented by  $p$ ,  $q$ ,  $r$  and  $s$ .

Which row represents the values of  $p$ ,  $q$ ,  $r$  and  $s$ ?

	$p / \text{mm}$	$q / \text{mm}$	$r / \text{mm}$	$s / \text{mm}$
<b>A</b>	1.0	1.4	1.7	2.0
<b>B</b>	1.0	2.0	3.0	4.0
<b>C</b>	1.0	2.0	4.0	8.0
<b>D</b>	1.0	4.0	9.0	16.0

- 20 A network of resistors, each of resistance  $1.0 \Omega$ , is connected as shown.

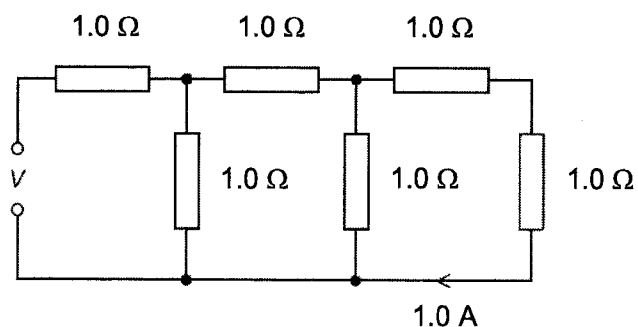

The current passing through the end resistor is  $1.0 \text{ A}$ .

What is the potential difference  $V$  across the input terminals?

- A  $2.0 \text{ V}$                       B  $5.0 \text{ V}$                       C  $8.0 \text{ V}$                       D  $13.0 \text{ V}$
- 21 Which graph shows the variation with current  $I$  of the potential difference  $V$  of a filament lamp?

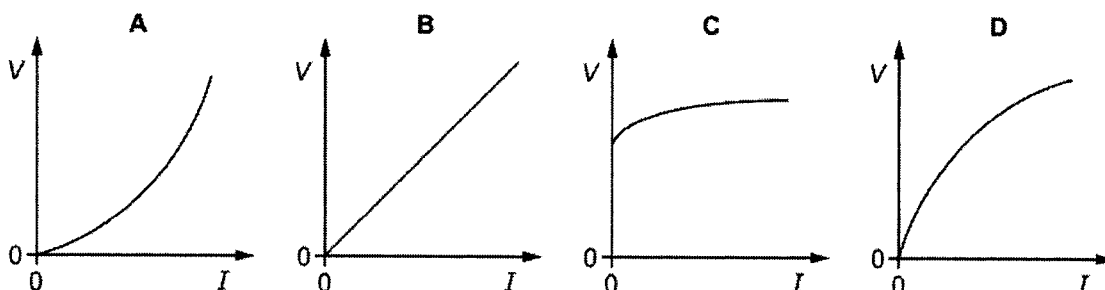

12

- 22 Three resistors are connected in parallel across a power supply, as shown.

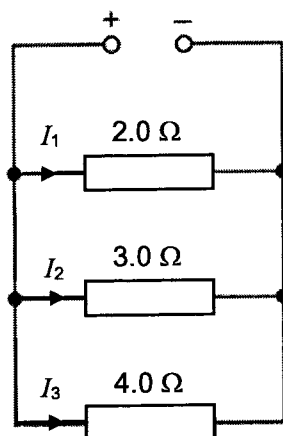

What is the ratio of the currents  $I_1 : I_2 : I_3$ ?

- A 3 : 4 : 6      B 6 : 4 : 3      C 9 : 16 : 18      D 18 : 16 : 9
- 23 The figure shows a horizontal power cable of length 2.0 m carrying a steady current  $I$  of 3.0 A into the plane of the paper.

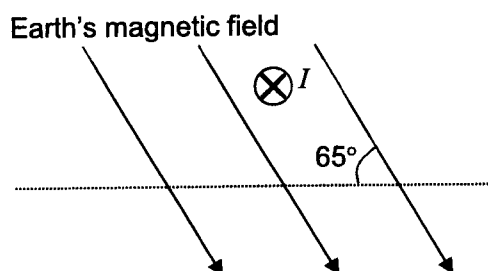

What is the force acting on the cable that is caused by the Earth's magnetic field of flux density  $4.0 \times 10^{-5}$  T, in a region where this field is at  $65^\circ$  to the horizontal?

- A  $82 \mu\text{N}$       B  $220 \mu\text{N}$       C  $240 \mu\text{N}$       D  $660 \mu\text{N}$

- 24 Two long and parallel wires carrying currents in the same direction separate the surrounding space into three regions 1, 2 and 3, as shown.

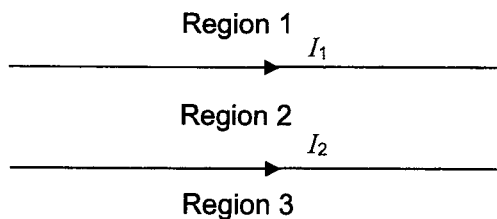

In which region(s) can there be a neutral point (i.e., a point of zero magnetic field)?

- A Region 2 only  
 B Both regions 1 and 3.  
 C Either region 1 or region 3 but not both.  
 D There are no neutral points.
- 25 A circuit consists of an a.c. supply, two diodes, and two resistors with resistance  $R_1$  and  $R_2$  respectively.

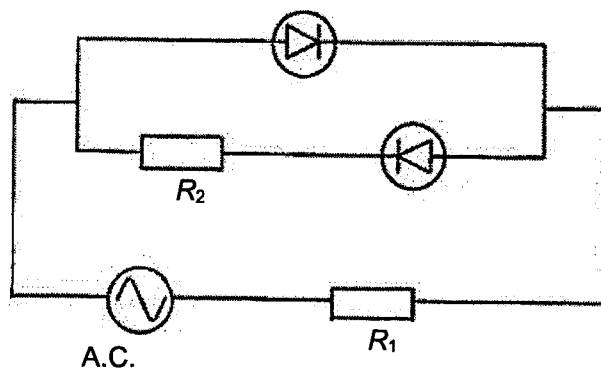

Which of the following graphs represents the variation of current  $I$  with time  $t$  through  $R_1$  of the circuit?

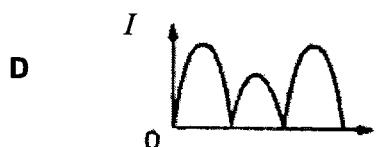
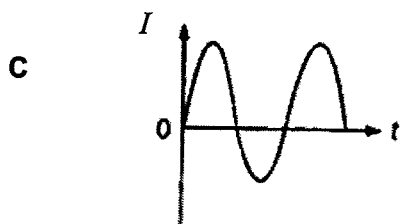
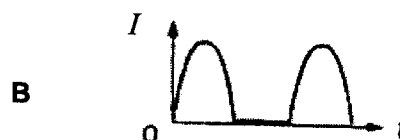
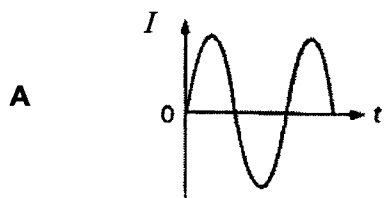

- 26 The magnetic flux,  $\Phi$ , through a coil varies with time,  $t$ , as shown by the first graph. Which one of the following graphs, best represents how the magnitude of the induced emf,  $\varepsilon$ , varies in this same period of time?

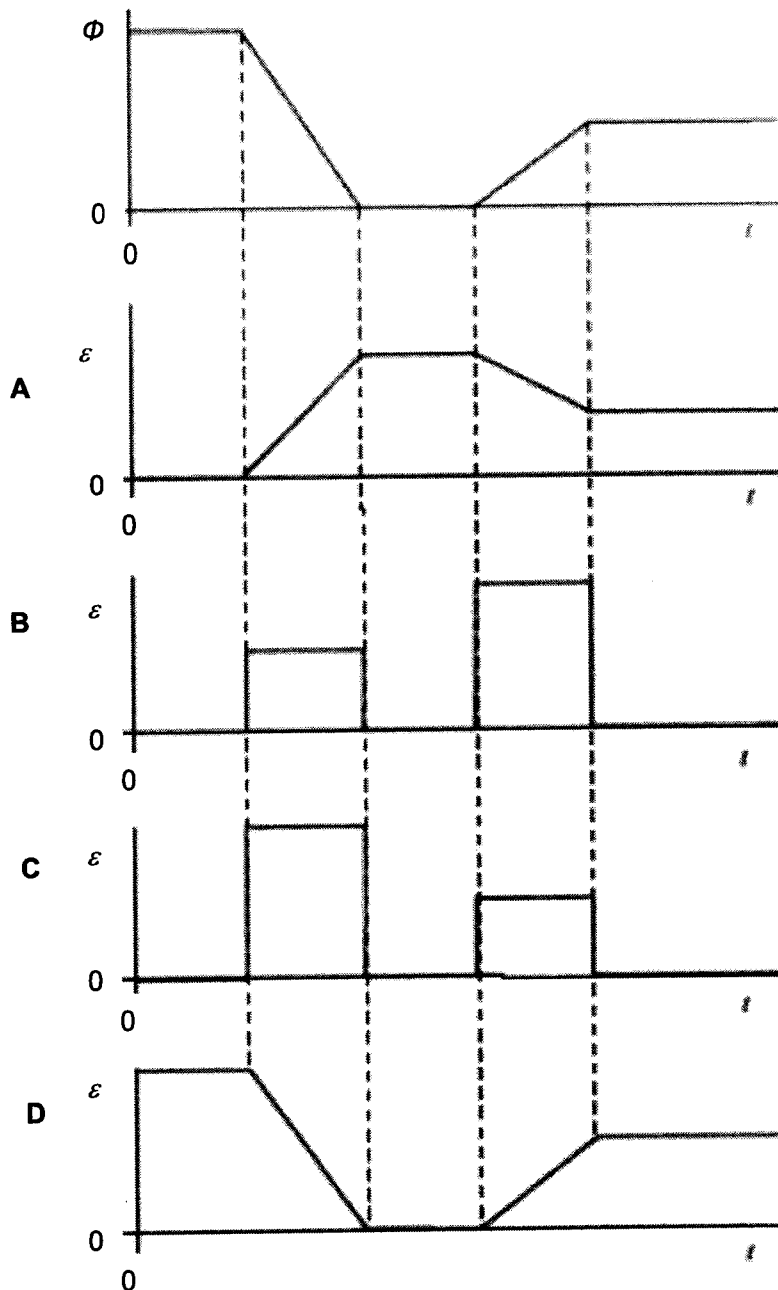

- 27 The stopping voltage when metal X is irradiated with light of wavelength  $\lambda$  and intensity  $I$  is  $V$ .

Which of the following is *most likely* the stopping voltage when metal X is irradiated with light of wavelength  $\lambda/2$  and intensity  $I/2$ ?

- A  $< V$                       B  $V$                       C  $2V$                       D  $> 2V$

- 28 Evidence for the wave-particle duality may be observed by the diffraction of an electron beam at a slit. A diffraction pattern is observed on a suitable screen.

For an electron passing through the slit, the uncertainty in its position  $\Delta x$  and the uncertainty in its momentum  $\Delta p$  are related by the following expression

$$\Delta p \Delta x \geq h$$

Which diagram below shows the positions where  $\Delta x$  and  $\Delta p$  in the equation above are defined and shows them in the correct direction?

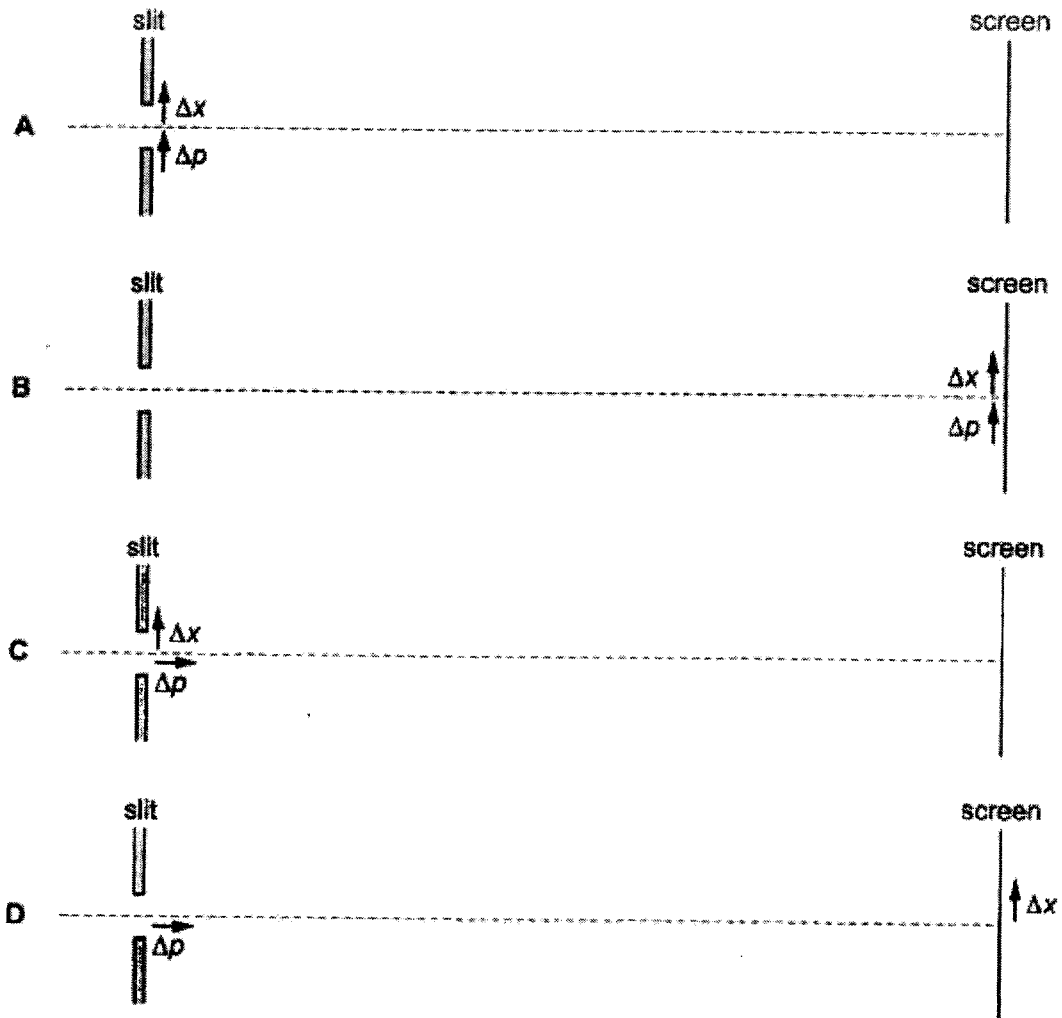

- 29 When the number of protons and the number of neutrons in a nuclide are both "magic numbers", it is more stable than expected. Such nuclides are termed "doubly magic". The first few "magic numbers" are 2, 8, 20, 28, 50, 82, and 126.

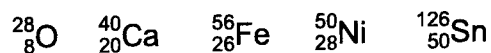

How many of the five nuclides above are "doubly magic"?

- A 1                      B 2                      C 3                      D 4
- 30 An experiment is carried out in which the count rate is measured at a fixed distance from a sample of a certain radioactive material. The figure below shows the variation of count rate with time.

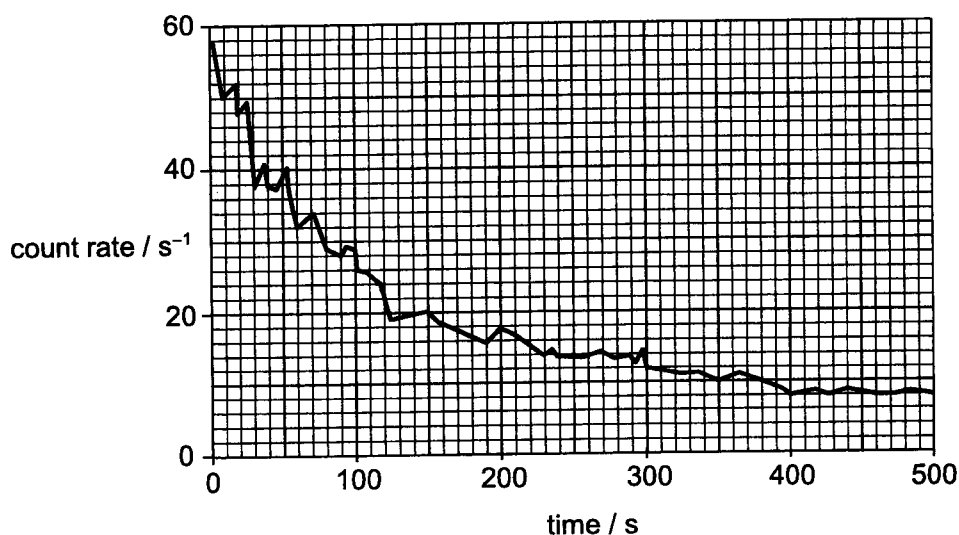

What is the approximate half-life of the material?

- A 60 s                      B 80 s                      C 100 s                      D 120 s



<b>Name:</b>		<b>Centre/Index Number:</b>		<b>Class:</b>	
--------------	--	-----------------------------	--	---------------	--



## DUNMAN HIGH SCHOOL Preliminary Examination Year 6

### H2 PHYSICS

Paper 2 Structured Questions

**9749/02**

**15 September 2022**

**2 hours**

Candidates answer on the Question Paper

#### READ THESE INSTRUCTIONS FIRST

Write your centre number, index number, name and class at the top of this page.

Write in dark blue or black pen.

You may use an HB pencil for any diagrams or graphs.

Do not use staples, paper clips, glue or correction fluid.

Answer **all** questions in the spaces provided on the question paper.

The use of an approved scientific calculator is expected, where appropriate.

You may lose marks if you do not show your working or if you do not use appropriate units.

The number of marks is given in brackets [ ] at the end of each question or part question.

For Examiner's Use	
1	10
2	9
3	6
4	6
5	8
6	9
7	10
8	22
<b>Total</b>	<b>80</b>

This document consists of **20** printed pages.

## 2

**Data**

speed of light in free space,	$c = 3.00 \times 10^8 \text{ m s}^{-1}$
permeability of free space,	$\mu_0 = 4\pi \times 10^{-7} \text{ H m}^{-1}$
permittivity of free space,	$\epsilon_0 = 8.85 \times 10^{-12} \text{ F m}^{-1}$ $(1/(36\pi)) \times 10^{-9} \text{ F m}^{-1}$
elementary charge,	$e = 1.60 \times 10^{-19} \text{ C}$
the Planck constant,	$h = 6.63 \times 10^{-34} \text{ J s}$
unified atomic mass constant,	$u = 1.66 \times 10^{-27} \text{ kg}$
rest mass of electron,	$m_e = 9.11 \times 10^{-31} \text{ kg}$
rest mass of proton,	$m_p = 1.67 \times 10^{-27} \text{ kg}$
molar gas constant,	$R = 8.31 \text{ J K}^{-1} \text{ mol}^{-1}$
the Avogadro constant,	$N_A = 6.02 \times 10^{23} \text{ mol}^{-1}$
the Boltzmann constant,	$k = 1.38 \times 10^{-23} \text{ J K}^{-1}$
gravitational constant,	$G = 6.67 \times 10^{-11} \text{ N m}^2 \text{ kg}^{-2}$
acceleration of free fall,	$g = 9.81 \text{ m s}^{-2}$

**Formulae**

uniformly accelerated motion,

$$s = ut + \frac{1}{2} at^2$$

$$v^2 = u^2 + 2as$$

work done on/by a gas,

$$W = p\Delta V$$

hydrostatic pressure,

$$p = \rho gh$$

gravitational potential,

$$\phi = -Gm/r$$

temperature,

$$T/K = T/^{\circ}\text{C} + 273.15$$

pressure of an ideal gas,

$$p = \frac{1}{3} \frac{Nm}{V} \langle c^2 \rangle$$

mean translational kinetic energy of an ideal gas molecule,

$$E = \frac{3}{2} kT$$

displacement of particle in s.h.m.,

$$x = x_0 \sin \omega t$$

velocity of particle in s.h.m.,

$$v = v_0 \cos \omega t$$

$$= \pm \omega \sqrt{x_0^2 - x^2}$$

electric current,

$$I = Anvq$$

resistors in series,

$$R = R_1 + R_2 + \dots$$

resistors in parallel,

$$1/R = 1/R_1 + 1/R_2 + \dots$$

electric potential,

$$V = \frac{Q}{4\pi\epsilon_0 r}$$

alternating current / voltage,

$$x = x_0 \sin \omega t$$

magnetic flux density due to a long straight wire,

$$B = \frac{\mu_0 I}{2\pi d}$$

magnetic flux density due to a flat circular coil,

$$B = \frac{\mu_0 NI}{2r}$$

magnetic flux density due to a long solenoid,

$$B = \mu_0 nI$$

radioactive decay,

$$x = x_0 \exp(-\lambda t)$$

decay constant,

$$\lambda = \frac{\ln 2}{t_{\frac{1}{2}}}$$

4

Answer **all** questions in the spaces provided.

- 1 A golfer strikes a ball so that it leaves the ground with a velocity of  $6.0 \text{ m s}^{-1}$  at an angle  $\theta$  to the horizontal, as illustrated in Fig. 1.1.

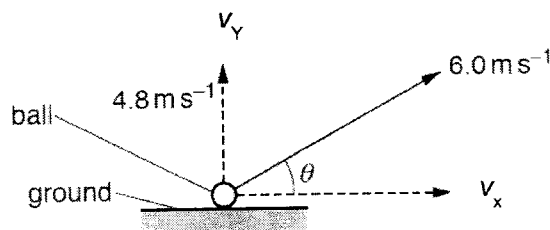

**Fig. 1.1** (not to scale)

The magnitude of the initial vertical component,  $v_y$ , of the velocity is  $4.8 \text{ m s}^{-1}$ . Assume that air resistance is negligible.

- (a) Show that the magnitude of the initial horizontal component,  $v_x$ , of the velocity is  $3.6 \text{ m s}^{-1}$ .

[1]

- (b) The ball leaves the ground at time  $t = 0$  and reaches its maximum height at  $t = 0.49 \text{ s}$ .

On Fig. 1.2, sketch separate lines to show the variation with time  $t$ , until the ball returns to the ground, of

- (i) the vertical component,  $v_y$ , of the velocity (label this line Y), [2]

- (ii) the horizontal component,  $v_x$ , of the velocity (label this line X). [2]

5

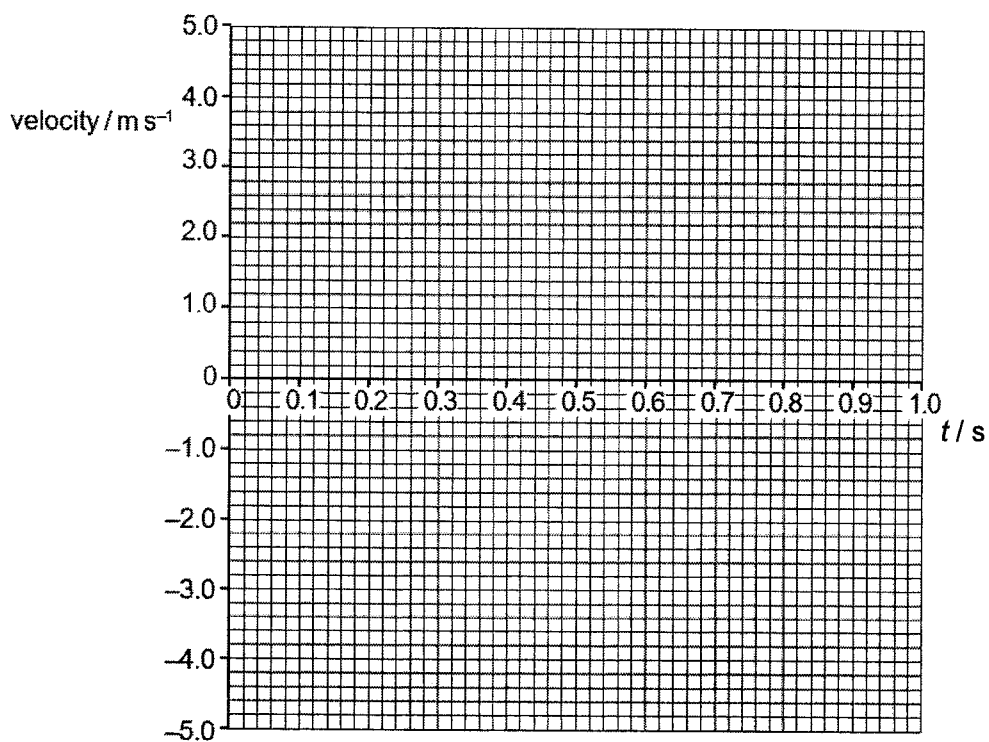

Fig. 1.2

- (c) Calculate the maximum height reached by the ball.

maximum height = ..... m [2]

- (d) For the movement of the ball from the ground to its maximum height, determine the ratio

$$\frac{\text{kinetic energy at maximum height}}{\text{change in gravitational potential energy}}$$

ratio = ..... [2]

(e) In practice, air resistance is not negligible.

State and explain how the actual time taken for the ball to reach maximum height is affected compared to the time calculated when air resistance is assumed to be negligible.

.....  
 ..... [1]

[Total: 10]

2 (a) The variation with extension  $x$  of the tension  $F$  in a spring is shown in Fig. 2.1.

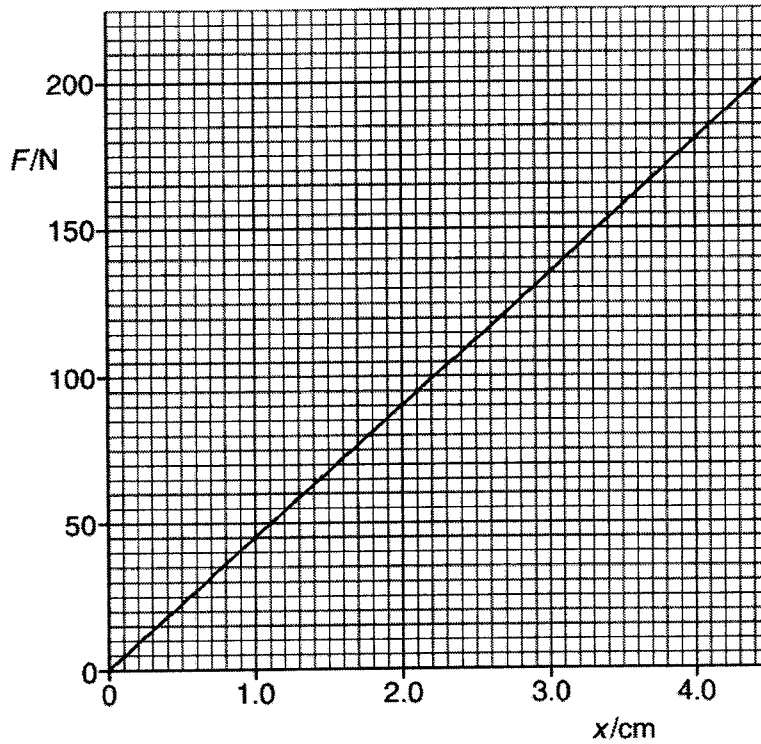

Fig. 2.1

Calculate the energy stored in the spring for an extension of 4.0 cm. Explain your working.

energy = ..... J [3]

- (b) The spring in (a) is used to join two frictionless trolleys A and B, of mass  $M_1$  and  $M_2$  respectively, as shown in Fig. 2.2.

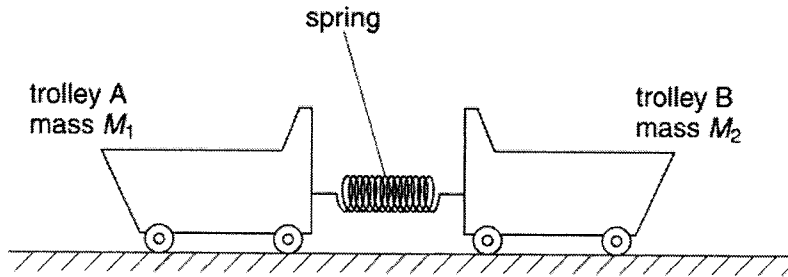

Fig. 2.2

The trolleys rest on a horizontal surface and are held apart so that the spring is extended. The trolleys are then released at the same time.

- (i) Explain why, as the extension of the spring is reduced, the momentum of trolley A is equal in magnitude but opposite in direction to the momentum of trolley B.

.....  
 .....  
 .....  
 ..... [2]

- (ii) At the instant when the extension of the spring is zero, trolley A has speed  $V_1$  and trolley B has speed  $V_2$ .

Write down

- 1. an equation, based on momentum, to relate  $V_1$  and  $V_2$ ,

..... [1]

- 2. an equation to relate the initial energy  $E$  stored in the spring to the final energies of the trolleys.

..... [1]

- (iii) 1. Show that the kinetic energy  $E_K$  of an object of mass  $m$  is related to its momentum  $p$  by the expression

$$E_K = \frac{p^2}{2m}$$

[1]

2. Trolley A has a bigger mass than trolley B. Use the expression in (iii)1. to deduce which trolley, A or B, has the larger kinetic energy at the instant when the extension of the spring is zero.

.....  
 ..... [1]

[Total: 9]

- 3 Two progressive sound waves Y and Z meet at a fixed point P. The variation with time  $t$  of the displacement  $x$  of each wave at point P is shown in Fig. 3.1.

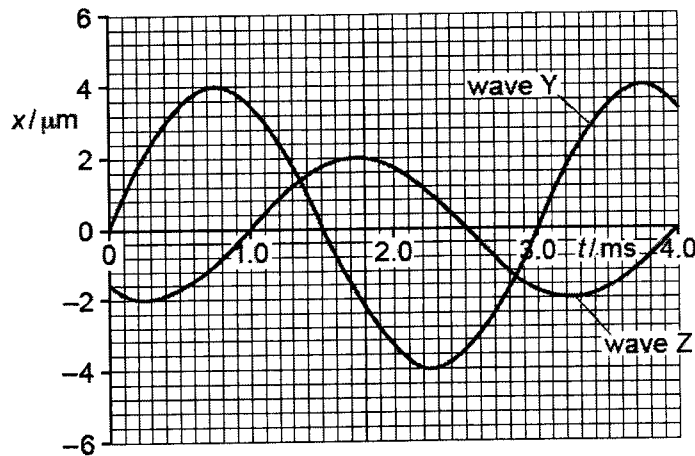

Fig. 3.1

- (a) Determine the phase difference between the waves.

phase difference = .....° [1]



- (b) The two waves superpose at P. Use Fig. 3.1 to determine the resultant displacement at time  $t = 0.75$  ms.

resultant displacement = ..... $\mu\text{m}$  [1]

- (c) The intensity of wave Y at point P is  $I$ .  
Determine, in terms of  $I$ , the intensity of wave Z.

intensity = ..... [2]

- (d) The speed of wave Z is  $330 \text{ m s}^{-1}$ .  
Determine the wavelength of wave Z.

wavelength = ..... m [2]

[Total: 6]

- 4 (a) The circuit in Fig. 4.1 contains a battery of electromotive force (e.m.f.)  $E$  and negligible internal resistance connected to four resistors  $R_1$ ,  $R_2$ ,  $R_3$  and  $R_4$ , each of resistance  $R$ .

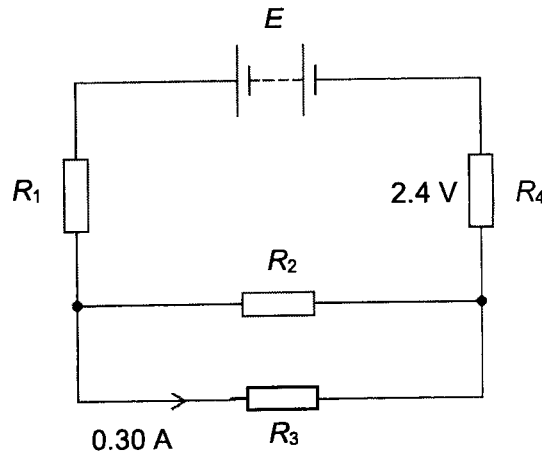

Fig. 4.1

The current in  $R_3$  is 0.30 A and the potential difference across  $R_4$  is 2.4 V.

- (i) Show that  $R$  is equal to 4.0  $\Omega$ .

[2]

- (ii) Determine the e.m.f.  $E$  of the battery.

$E = \dots\dots\dots$  V [2]

- (b) The battery in (a) is replaced with another battery of the same e.m.f. but with an internal resistance that is not negligible.

State and explain the change, if any, in the total power produced by the battery.

.....

..... [2]

[Total: 6]

- 5 Fig. 5.1 shows a simple laminated iron core transformer consisting of a primary coil of 25 000 turns and a secondary coil of 625 turns.

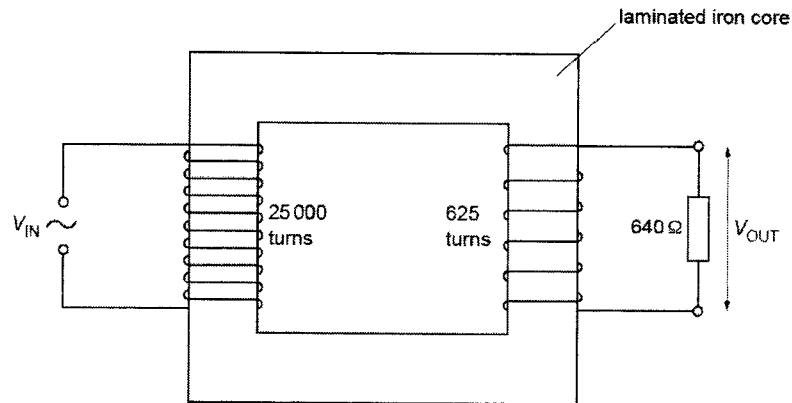

Fig. 5.1

The output potential difference  $V_{OUT}$  is applied to a load resistor of  $640 \Omega$ .

- (a) (i) State the function of the iron core.

.....  
 ..... [1]

- (ii) Explain why the iron core is laminated.

.....  
 .....  
 .....  
 ..... [2]

- (b) The input p.d.  $V_{IN}$  is a sinusoidal alternating voltage of peak value 12 kV and period 40 ms.

- (i) Calculate the maximum value of  $V_{OUT}$ .

maximum  $V_{OUT} = \dots\dots\dots V$  [1]

(ii) Calculate the root-mean-square (r.m.s.) current in the load resistor.

r.m.s. current = ..... A [1]

(iii) On Fig. 5.2, sketch the variation with time  $t$  of the power  $P$  dissipated in the load resistor for time  $t = 0$  to  $t = 40$  ms. Assume that  $P = 0$  when  $t = 0$ .

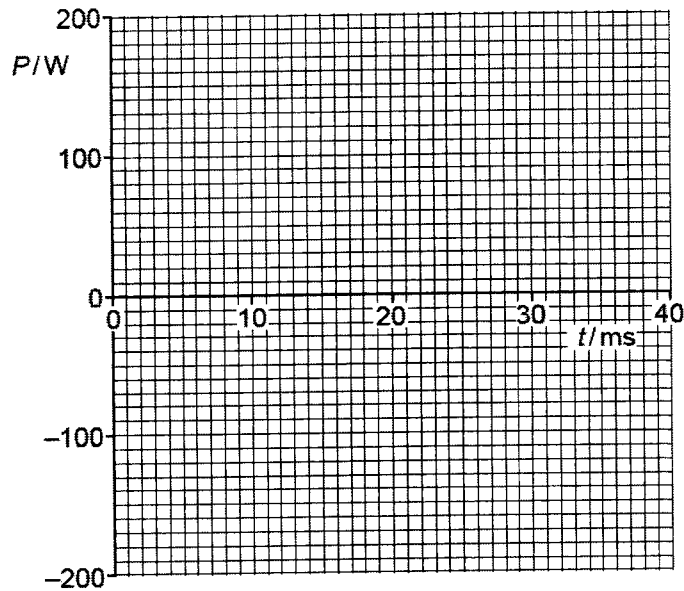

Fig. 5.2

[2]

(c) Deduce, with reference to Fig. 5.2, the mean power in the load resistor.

.....  
.....  
.....  
..... [1]

[Total: 8]

- 6 (a) State an experimental phenomenon that provides evidence for the wave nature of matter.

..... [1]

- (b) Electrons are accelerated from rest through a potential difference of 4.8 kV.

Calculate the de Broglie wavelength of the beam of electrons.

wavelength = ..... m [3]

- (c) A polished calcium plate in a vacuum is investigated by illuminating the surface with light. It is found that no photoelectric current is produced when the frequency of the light is less than  $6.93 \times 10^{14}$  Hz.

- (i) Explain how the particulate nature of electromagnetic radiation accounts for this phenomenon.

.....  
 .....  
 .....  
 .....  
 .....  
 ..... [3]

- (ii) Calculate the work function of calcium.

work function = ..... eV [2]

[Total: 9]

- 7 Strontium-90 decays with the emission of a  $\beta$ -particle to form Yttrium-90. The reaction is represented by the equation

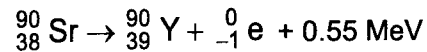

The half-life of Strontium-90 is 27.7 years

- (a) Define *half-life*.

.....  
 ..... [1]

- (b) Suggest, with a reason, which nuclide  ${}_{38}^{90}\text{Sr}$  or  ${}_{39}^{90}\text{Y}$  has a greater binding energy.

.....  
 .....  
 .....  
 .....  
 ..... [3]

- (c) At the time of purchase of a Strontium-90 source, the activity is  $3.7 \times 10^6$  Bq.

- (i) Calculate, for this sample of strontium,

1. the initial number of atoms,

initial number = ..... [2]

2. the initial mass.

initial mass = .....kg [2]

- (ii) Determine  $\frac{A}{A_0}$ , where  $A$  is the activity of the sample 5.0 years after purchase and  $A_0$  is the initial activity.

$$\frac{A}{A_0} = \dots\dots\dots [2]$$

[Total: 10]

- 8 In the late 17th century, scientists were embroiled in a debate about the fundamental nature of light – whether it was a wave or a particle. In the 1860, the Scottish physicist James Clerk Maxwell described light as a propagating wave of electric and magnetic fields. This Wave Theory of light is successful in explaining the laws of reflection and refraction of light, as well as the diffraction and interference effects of light in the Thomas Young double slit experiment. According to the Wave Theory, energy is emitted continuously.

However, the Wave Theory of light cannot explain the concept of blackbody radiation. Fig 8.1 shows how the intensity  $I$  of the emitted radiation varies with its wavelength  $\lambda$  at the different temperatures. In 1900, the German physicist Max Planck, introduced the idea that energy is quantised to explain the observation that with increasing temperature of the body, the peak of the radiation curve shifts to shorter wavelength with higher intensity.

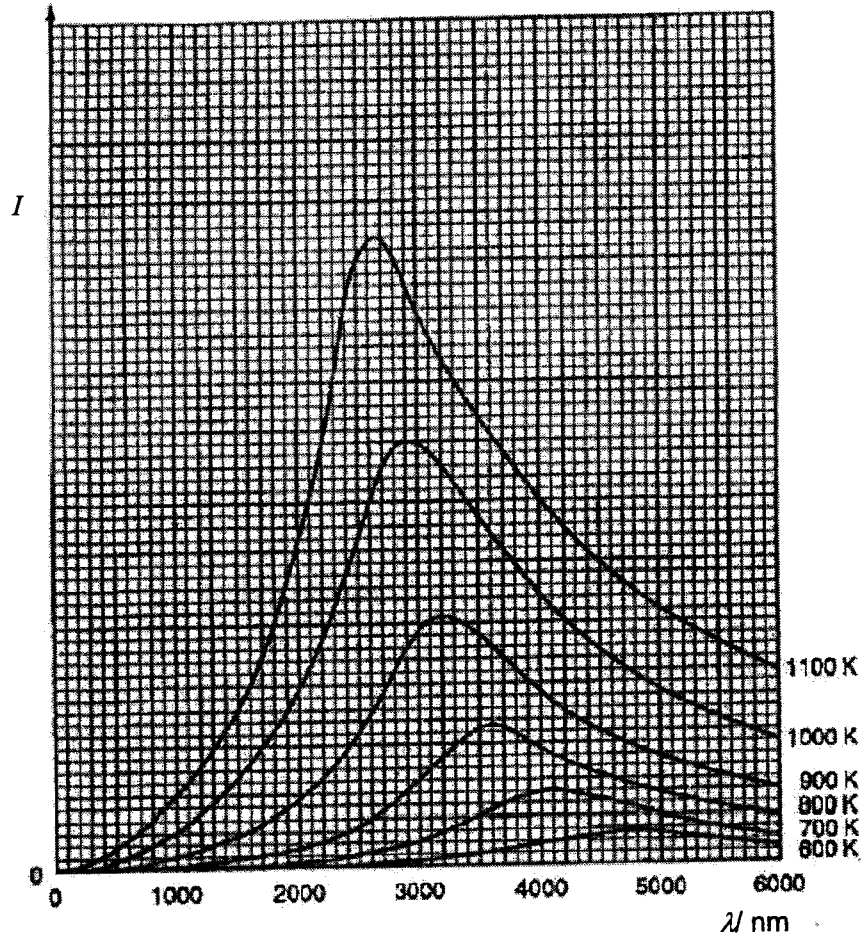

Fig. 8.1

(a) Explain what is meant by energy is *quantised*.

.....  
 ..... [1]

(b) (i) On the horizontal axis of Fig. 8.1, indicate with the letter V, a wavelength that is in the visible region of the electromagnetic spectrum. [1]

(ii) Use Fig. 8.1 to suggest why, at a temperature of 1100 K, the object would glow with a red colour.

.....  
 .....  
 ..... [2]



(c) The radiation emitted by a body may be used as a means to determine the temperature of the body.

(i) Suggest and explain a property of the radiation that could be used for this purpose.

.....  
 ..... [1]

(ii) Suggest one advantage and one disadvantage of this method of measuring temperature.

advantage: .....  
 ..... [1]

disadvantage: .....  
 ..... [1]

The Wave Theory also does not explain the line spectra of hydrogen. In 1913, a Danish physicist, Neils Bohr successfully matched the wavelength of the emission line spectra to the discrete energy levels in hydrogen, again using quantisation. In the Bohr model, the hydrogen atom is pictured as a heavy, positively charged nucleus orbited by a light, negatively charged electron. According to Bohr, the angular momentum, which is the product of the linear momentum of the electron and its radius of orbit around the nucleus, is quantised. He further added that the electron with linear momentum  $p$  can only move in those orbits with radius  $r$  provided the angular momentum of the electron is an integer multiple of  $\frac{h}{2\pi}$

$$\text{angular momentum} = pr = \frac{nh}{2\pi}$$

where  $n$  is a positive integer and  $h$  is the Planck constant.

At the ground state, the electron is in the smallest orbit, with the lowest energy, and has an orbital radius known as the Bohr radius.

- (d) (i) Show that the linear speed  $v$ , in  $\text{m s}^{-1}$ , of the electron in the hydrogen atom is related to its orbital radius  $r$ , in m, by

$$v = \frac{15.9}{\sqrt{r}}$$

[3]

- (ii) Using your expression in (d)(i) to calculate the Bohr radius  $r_0$ .

 $r_0 = \dots\dots\dots \text{nm}$  [2]

- (iii) Hence, by considering the potential and kinetic energies of the electron, show that the total energy of the electron in the ground state is  $-13.6$  eV.

[2]

- (e) The measured wavelength,  $\lambda$ , of selected lines in the hydrogen spectrum are given empirically by

$$\frac{1}{\lambda} = 1.097 \times 10^7 \left( 1 - \frac{1}{n^2} \right)$$

where  $n$  is an integer greater than or equal to one.

Fig. 8.2 represents part of the emission spectrum of atomic hydrogen. It contains a series of lines, the wavelengths of some of which are marked.

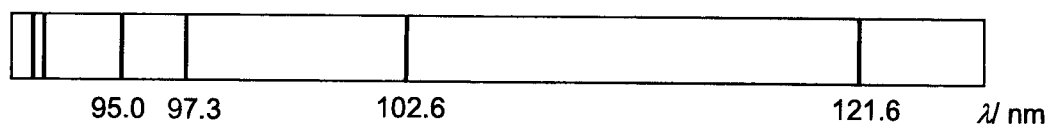

**Fig. 8.2**

These lines are part of the Lyman series due to electron transitions from higher energy levels to the ground state.

- (i) Calculate the minimum wavelength given by this equation.

wavelength = ..... nm [1]

- (ii) Show that the energy  $E$  of a photon and its wavelength  $\lambda$  are related by

$$E\lambda = 1.99 \times 10^{-16} \text{ J nm}$$

[2]

- (iii) Use the relation given in (e)(ii), complete Fig. 8.3 to determine the photon energies equivalent to all the wavelengths marked in Fig. 8.2.

wavelength $\lambda$ / nm	$E = \frac{hc}{\lambda}$ / eV
121.6	
102.6	
97.3	
95.0	

Fig. 8.3

[1]

- (iv) Use your answers in (e)(iii) to map a partial energy level diagram for hydrogen. You can leave your energy levels to 3 significant figures. Show and label clearly, the electron transitions responsible for the emission lines with labelled wavelengths in Fig. 8.2.

[3]

- (v) Another emission line in the hydrogen spectrum occurs at a wavelength of 434.1 nm. Identify and label on your answer in (e)(iv) the electron transition responsible for this line.

[1]

[Total: 22]

<b>Name:</b>		<b>Centre/Index Number:</b>		<b>Class:</b>	
--------------	--	-----------------------------	--	---------------	--



**DUNMAN HIGH SCHOOL**  
**Preliminary Examination**  
**Year 6**

**H2 PHYSICS**

Paper 3 Longer Structured Questions

**9749/03**

**22 September 2022**

**2 hours**

Candidates answer on the Question Paper

**READ THESE INSTRUCTIONS FIRST**

Write your centre number, index number, name and class at the top of this page.

Write in dark blue or black pen.

You may use an HB pencil for any diagrams or graphs.

Do not use staples, paper clips, glue or correction fluid.

**Section A**

Answer **all** questions.

**Section B**

Answer any **one** question.

The use of an approved scientific calculator is expected, where appropriate.

You may lose marks if you do not show your working or if you do not use appropriate units.

The number of marks is given in brackets [ ] at the end of each question or part question.

<b>For Examiner's Use</b>	
<b>Section A</b>	
1	4
2	10
3	10
4	9
5	8
6	8
7	11
<b>Section B</b>	
8 / 9	20
<b>Total</b>	<b>80</b>

This document consists of **24** printed pages and **2** blank pages.

## 2

**Data**

speed of light in free space,	$c = 3.00 \times 10^8 \text{ m s}^{-1}$
permeability of free space,	$\mu_0 = 4\pi \times 10^{-7} \text{ H m}^{-1}$
permittivity of free space,	$\epsilon_0 = 8.85 \times 10^{-12} \text{ F m}^{-1}$ $(1/(36\pi)) \times 10^{-9} \text{ F m}^{-1}$
elementary charge,	$e = 1.60 \times 10^{-19} \text{ C}$
the Planck constant,	$h = 6.63 \times 10^{-34} \text{ J s}$
unified atomic mass constant,	$u = 1.66 \times 10^{-27} \text{ kg}$
rest mass of electron,	$m_e = 9.11 \times 10^{-31} \text{ kg}$
rest mass of proton,	$m_p = 1.67 \times 10^{-27} \text{ kg}$
molar gas constant,	$R = 8.31 \text{ J K}^{-1} \text{ mol}^{-1}$
the Avogadro constant,	$N_A = 6.02 \times 10^{23} \text{ mol}^{-1}$
the Boltzmann constant,	$k = 1.38 \times 10^{-23} \text{ J K}^{-1}$
gravitational constant,	$G = 6.67 \times 10^{-11} \text{ N m}^2 \text{ kg}^{-2}$
acceleration of free fall,	$g = 9.81 \text{ m s}^{-2}$

**Formulae**

uniformly accelerated motion,

$$s = ut + \frac{1}{2}at^2$$

$$v^2 = u^2 + 2as$$

work done on/by a gas,

$$W = p\Delta V$$

hydrostatic pressure,

$$p = \rho gh$$

gravitational potential,

$$\phi = -Gm/r$$

temperature,

$$T/K = T/^{\circ}\text{C} + 273.15$$

pressure of an ideal gas,

$$p = \frac{1}{3} \frac{Nm}{V} \langle c^2 \rangle$$

mean translational kinetic energy of an ideal gas molecule,

$$E = \frac{3}{2}kT$$

displacement of particle in s.h.m.,

$$x = x_0 \sin \omega t$$

velocity of particle in s.h.m.,

$$v = v_0 \cos \omega t$$

$$= \pm \omega \sqrt{x_0^2 - x^2}$$

electric current,

$$I = Anvq$$

resistors in series,

$$R = R_1 + R_2 + \dots$$

resistors in parallel,

$$1/R = 1/R_1 + 1/R_2 + \dots$$

electric potential,

$$V = \frac{Q}{4\pi\epsilon_0 r}$$

alternating current / voltage,

$$x = x_0 \sin \omega t$$

magnetic flux density due to a long straight wire,

$$B = \frac{\mu_0 I}{2\pi d}$$

magnetic flux density due to a flat circular coil,

$$B = \frac{\mu_0 NI}{2r}$$

magnetic flux density due to a long solenoid,

$$B = \mu_0 nI$$

radioactive decay,

$$x = x_0 \exp(-\lambda t)$$

decay constant,

$$\lambda = \frac{\ln 2}{t_{\frac{1}{2}}}$$

4

## Section A

Answer **all** the questions in this section in the spaces provided.

1 (a) Make estimates of

(i) the mass, in kg, of a wooden metre rule,

mass = ..... kg [1]

(ii) the volume, in cm<sup>3</sup>, of a tennis ball.

volume = ..... cm<sup>3</sup> [1]

(b) The energy  $E$  stored in an electrical component is given by

$$E = \frac{Q^2}{2C}$$

where  $Q$  is charge and  $C$  is a constant.

Use this equation to determine the SI base units of  $C$ .

SI base units of  $C$  = ..... [2]

[Total: 4]



- 2 (a) A lump of pure ice floats on pure water in a beaker, as shown in Fig. 2.1.

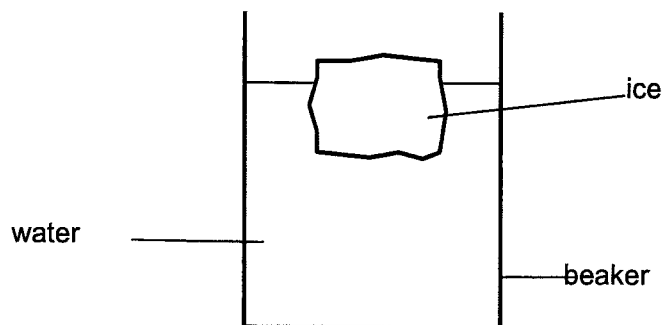

Fig. 2.1

- (i) State, qualitatively, the relation between

1. the mass of the ice and the mass of the displaced water,

..... [1]

2. the density of ice and the density of water.

..... [1]

- (ii) A student marks the level of water surface in the beaker and then observes the level as the ice melts. State and explain qualitatively the change, if any, in this level during the melting. Ignore the effects of evaporation.

.....

.....

.....

.....

..... [3]

6

- (b) A heavy anchor of volume  $0.50 \text{ m}^3$  and density  $7800 \text{ kg m}^{-3}$  lies at the bottom of the seabed. A fisherman intends to use a lifting bag to raise the anchor from the seabed. Take the density of sea water to be  $1030 \text{ kg m}^{-3}$ .

- (i) Explain what is meant by *upthrust*.

.....

..... [1]

- (ii) Determine the upthrust acting on the anchor.

upthrust = ..... N [2]

- (iii) Determine the volume of air that needs to be released into the lifting bag suddenly in order that the initial acceleration of the anchor is  $2.50 \text{ m s}^{-2}$ .

volume of air = .....  $\text{m}^3$  [2]

[Total: 10]

**BLANK PAGE**

- 3 A trolley on a track is attached by springs to fixed blocks X and Y, as shown in Fig. 3.1. The track contains many small holes through which air is blown vertically upwards. This results in the trolley resting on a cushion of air rather than being in direct contact with the track.

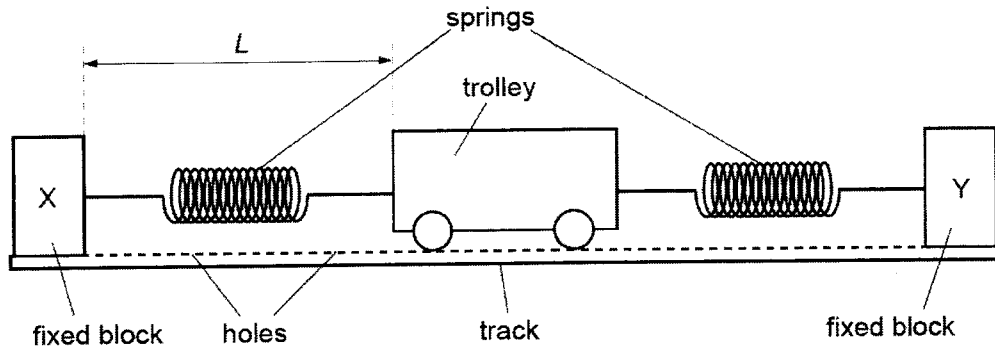

Fig. 3.1

The trolley is pulled to one side of its equilibrium position and then released so that it oscillates initially with simple harmonic motion. After a short time, the air blower is switched off. The variation with time  $t$  of the distance  $L$  of the trolley from block X is shown in Fig. 3.2.

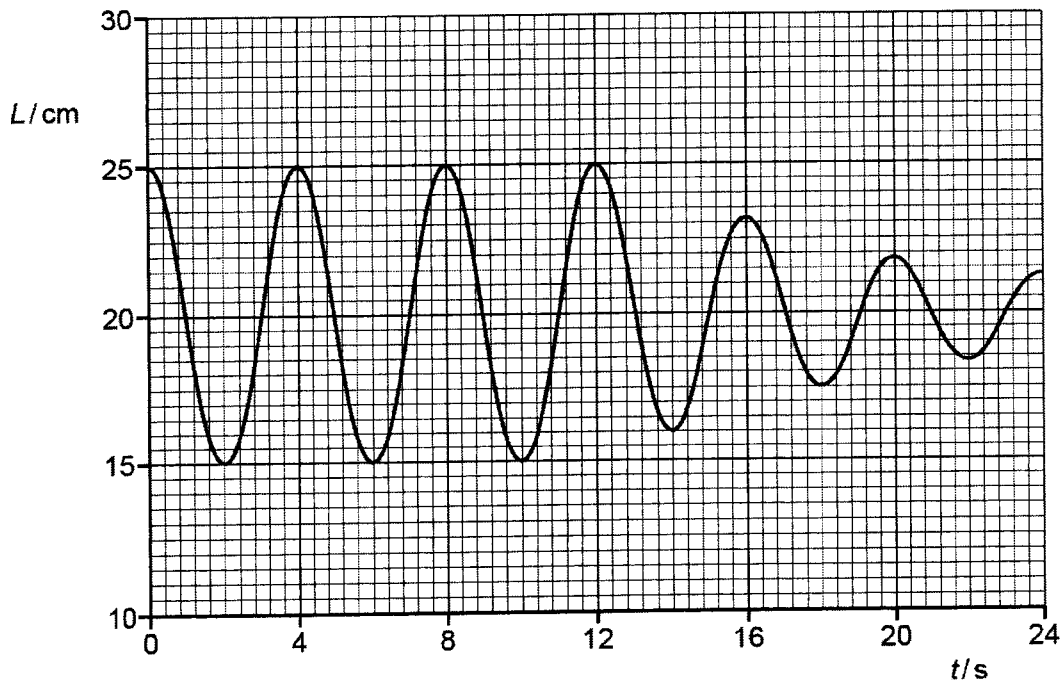

Fig. 3.2

- (a) Use Fig. 3.2 to determine:  
 (i) the initial amplitude of the oscillations,

amplitude = ..... cm [1]

9

- (ii) the angular frequency  $\omega$  of the oscillations,

$$\omega = \dots\dots\dots \text{ rad s}^{-1} \text{ [2]}$$

- (iii) the maximum speed  $v_0$ , of the oscillating trolley.

$$v_0 = \dots\dots\dots \text{ cm s}^{-1} \text{ [2]}$$

- (b) Apart from the quantities in (a), describe what may be deduced from Fig. 3.2 about the motion of the trolley between time  $t = 0$  and time  $t = 24$  s. No calculations are required.

.....  
 .....  
 .....  
 .....  
 ..... [3]

- (c) On Fig. 3.3, sketch the variation with  $L$  of the velocity  $v$  of the trolley for its first complete oscillation.

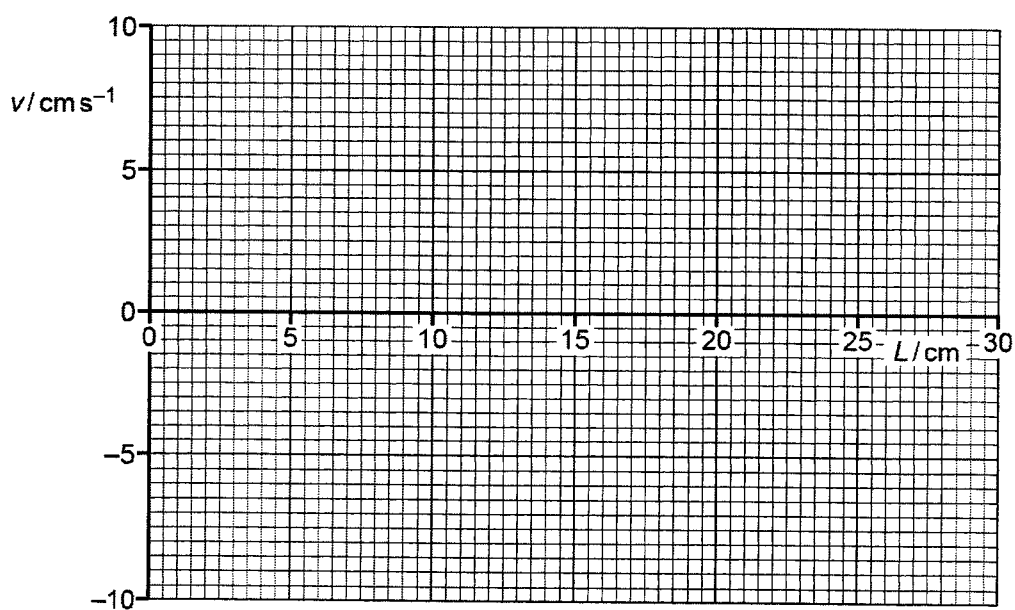
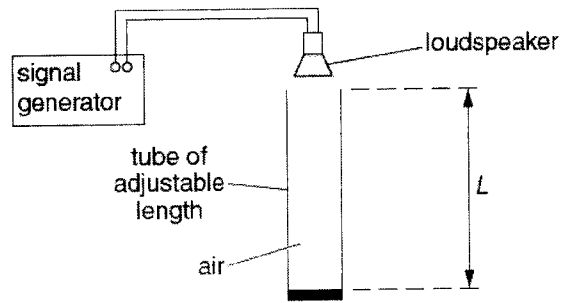

Fig. 3.3

[2]

[Total: 10]

- 4 An arrangement for producing stationary waves in air in a tube that is closed at one end is shown in Fig. 4.1



**Fig. 4.1**

A loudspeaker produces sound waves of wavelength 0.680 m in the tube. For some values of the length  $L$  of the tube, stationary waves are formed.

- (a) The length  $L$  is adjusted between 0.200 m and 1.00 m.  
 (i) Determine the two values of  $L$  for which stationary waves are formed.

$L = \dots\dots\dots$  m and  $\dots\dots\dots$  m [2]

- (ii) On Fig. 4.2, label the positions of all the antinodes with an **A** and the nodes with an **N** for the smallest value of  $L$  for which a stationary wave is formed.



**Fig. 4.2**

[1]

- (b) A light wave from a laser has a wavelength of 460 nm in a vacuum. The light is incident normally on a diffraction grating.

Describe the diffraction of the light waves at the grating.

.....  
 .....  
 ..... [2]

- (c) A diffraction grating is used with different wavelengths of visible light. The angle  $\theta$  of the **fourth-order** maximum from the zero-order (central) maximum is measured for each wavelength. The variation with wavelength  $\lambda$  of  $\sin \theta$  is shown in Fig. 4.3.

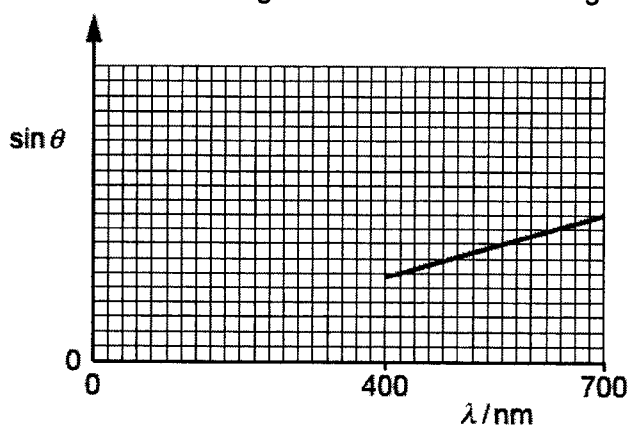

Fig. 4.3

- (i) The gradient of the graph is  $G$ .  
 Determine an expression, in terms of  $G$ , for the distance  $d$  between the centres of two adjacent slits in the diffraction grating.

$$d = \dots\dots\dots \text{ m [2]}$$

- (ii) On Fig. 4.3, sketch a graph to show the results that would be obtained for the **second-order** maxima. [2]

[Total: 9]

- 5 (a) Fig. 5.1 shows a proton moving at velocity  $v$  in a uniform magnetic field of flux density  $B$ .

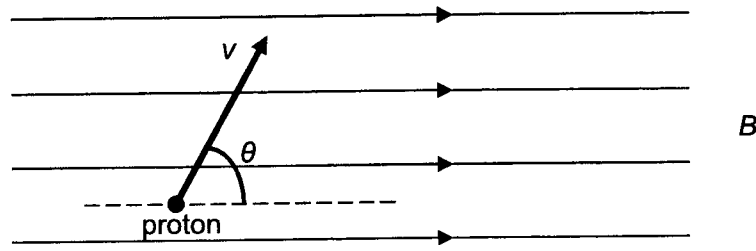

Fig. 5.1

The initial direction of the proton is at an angle  $\theta$  to the direction of the magnetic field.

By considering the components of the velocity parallel to the magnetic field and at right-angles to the magnetic field, describe and explain qualitatively the motion of the proton in the field.

.....

.....

.....

.....

.....

.....

.....

.....

.....

.....

..... [4]

- (b) A magnetic bottle may be created in the laboratory using two identical parallel circular coils placed along a central axis passing through the centre of each, as shown in Fig. 5.2.

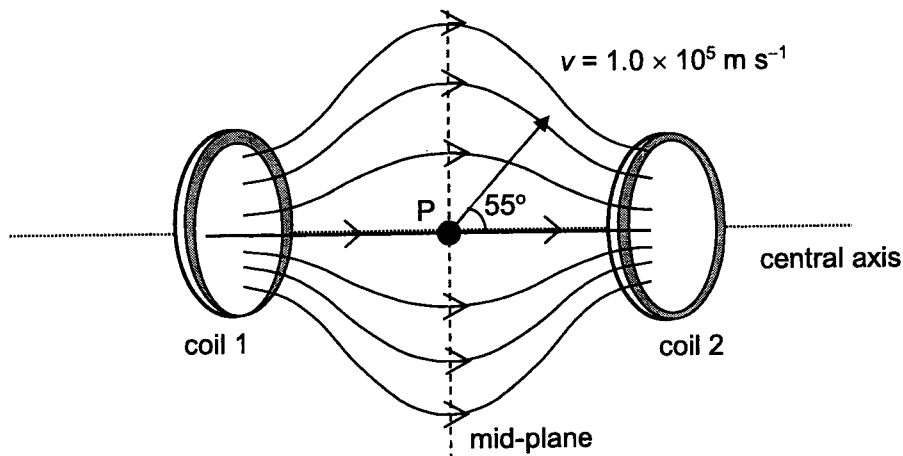

Fig. 5.2 (not to scale)



The magnetic field produced has a minimum value of  $3.8 \times 10^{-4}$  T halfway between the coils (along the mid-plane) and increases symmetrically to a maximum value of  $170 \times 10^{-4}$  T at the locations of the coils.

- (i) On Fig. 5.2, draw the direction of the current passing through each coil. [1]
- (ii) A proton P was detected moving with a velocity  $v = 1.0 \times 10^5$  m s<sup>-1</sup> at  $55^\circ$  to the horizontal when it was at the mid-plane and along the central axis of these coils as shown in Fig. 5.2. At that point, the magnetic field line is horizontal.

Calculate the magnitude of the magnetic force acting on the proton at that point.

magnetic force = ..... N [2]

- (iii) On Fig. 5.3, sketch a graph to show the variation with distance of the magnitude of the magnetic flux density along the central axis between the coils.

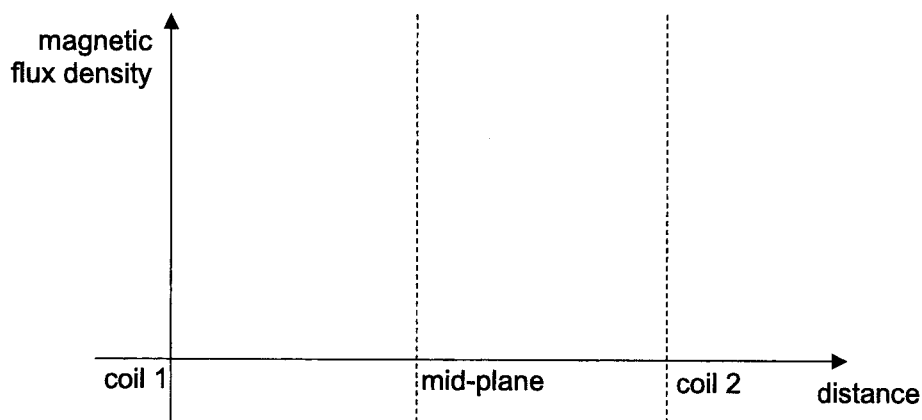

Fig. 5.3

[1]

[Total: 8]

6 (a) A solenoid is connected in series with a battery and a switch, as illustrated in Fig. 6.1.

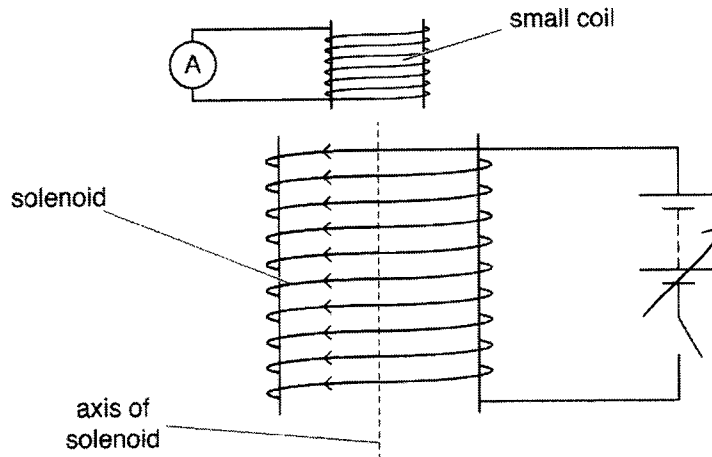

Fig. 6.1

A small coil, connected to a sensitive ammeter, is situated near one end of the solenoid. As the current in the solenoid is switched on, there is a deflection in the ammeter.

(i) State Lenz's law.

.....  
.....  
..... [1]

(ii) Use Lenz's law to state and explain the direction of the magnetic field in the small coil.

.....  
.....  
.....  
.....  
..... [3]

(iii) On Fig. 6.1, mark the direction of the induced current in the small coil. [1]

15

- (b) The small coil has an area of cross-section  $7.0 \times 10^{-4} \text{ m}^2$  and contains 75 turns of wire. A constant current in the solenoid produces a uniform magnetic flux of flux density 1.4mT throughout the small coil. The current is switched off in a time of 0.12s.

Calculate the average e.m.f. induced in the small coil.

e.m.f. = .....V [3]

[Total: 8]

- 7 (a) The  $^{226}_{88}\text{Ra}$  nucleus undergoes alpha decay according to

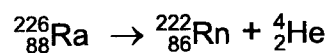

Data for the nuclei in the reaction are given in Fig. 7.1.

nucleus	mass / $u$
$^{226}_{88}\text{Ra}$	226.0254
$^{222}_{86}\text{Rn}$	222.0176
$^4_2\text{He}$	4.0026

Fig. 7.1

- (i) Show that the energy released in this decay,  $Q$ , is 4.86 MeV.

[2]

- (ii) This energy,  $Q$ , must be shared by the alpha particle and the daughter nucleus.

Use conservation of energy and momentum to show that

$$Q = K_{\alpha} \left( 1 + \frac{M_{\alpha}}{M} \right)$$

where  $K_{\alpha}$  is the kinetic energy of the alpha particle,  $M_{\alpha}$  is the mass of the alpha particle, and  $M$  is the mass of the daughter nucleus.

[3]

- (iii) 1. Hence calculate the kinetic energy of the alpha particle emitted in this decay process.

kinetic energy = ..... MeV [2]

2. Comment on your answer in (a)(iii)1. with reference to (a)(i).

..... [1]

- (b) The alpha particle produced in this decay travelled 25 mm in a cloud chamber. Given that, on average, an alpha particle creates  $5.0 \times 10^3$  ion pairs per mm of track in the cloud chamber, determine the energy required to produce an ion pair.

Energy required to produce an ion pair = ..... J [3]

[Total: 11]

## Section B

Answer **one** question from this section in the spaces provided.

- 8 (a) A cube of length  $L$  contains  $N$  molecules of an ideal gas. A molecule of mass  $m$  moves with velocity  $u$  towards the face of the box that is shaded in Fig. 8.1.

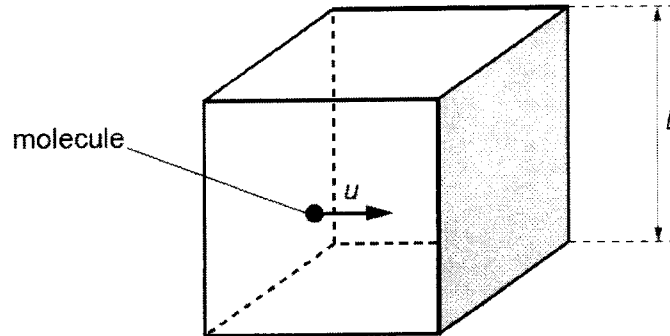

Fig. 8.1

The molecule collides elastically with the shaded face and the face opposite to it alternately.

Deduce expressions, in terms of  $N$ ,  $m$ ,  $u$  and  $L$ , for:

- (i) the magnitude of the change in momentum of the molecule on colliding with a face,

change in momentum = ..... [1]

- (ii) the time between consecutive collisions of the molecule with the shaded face,

time = ..... [1]

- (iii) the average force exerted by the molecules on the shaded face,

force = ..... [1]

(iv) the pressure on the shaded face.

pressure = ..... [1]

(b) (i) When the model described in (a) is extended to three dimensions, it can be shown that

$$pV = \frac{1}{3} Nm \langle c^2 \rangle$$

where  $p$  is the pressure exerted by the gas,  $V$  is the volume of the gas and  $\langle c^2 \rangle$  is the mean square speed of the molecules,

Explain how your answer in (a)(iv) leads to the above equation.

[3]

(ii) Use this expression to show that the average translational kinetic energy  $E_k$  of a molecule of an ideal gas is given by

$$E_k = \frac{3}{2} kT$$

where  $T$  is the thermodynamic temperature of the gas and  $k$  is the Boltzmann constant.

[2]

- (c) The mass of a hydrogen molecule is  $3.34 \times 10^{-27}$  kg.

Use the expression for  $E_k$  in (b) (ii) to determine the root-mean-square (r.m.s.) speed of the molecules of hydrogen gas at  $25^\circ\text{C}$ .

r.m.s. speed = .....  $\text{m s}^{-1}$  [2]

- (d) Explain why the internal energy of the gas is equal to the total kinetic energy of the molecules.

.....  
 ..... [2]

- (e) The gas in (a) is supplied with thermal energy  $Q$ .

- (i) Explain, with reference to the first law of thermodynamics, why the increase in internal energy of the gas is  $Q$ .

.....  
 .....  
 ..... [2]

- (ii) Define *specific heat capacity*.

.....  
 .....  
 ..... [1]

- (iii) Use the expression in (b) (ii) and the information in (e) (i) to show that the specific heat capacity  $c$  of the gas is given by

$$c = \frac{3k}{2m}$$

[2]



- (f) The container in (a) is now replaced with one that does not have a fixed volume. Instead, the gas is able to expand, so that the pressure of the gas remains constant as thermal energy is supplied.

Suggest, with a reason, how the specific heat capacity of the gas would now compare with the value in (e)(iii).

.....

..... [2]

[Total: 20]

- 9 (a) State one similarity and one difference between the fields of force produced by an isolated point charge and by an isolated point mass.

similarity: .....

.....

difference: .....

..... [2]

- (b) Two horizontal metal plates are separated by a distance of 1.8 cm in a vacuum. A potential difference of 270 V is maintained between the plates, as shown in Fig. 9.1.

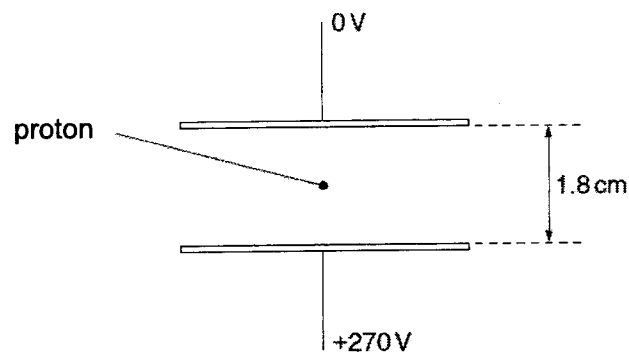

Fig. 9.1

A proton is in the space between the plates.

Explain quantitatively why, when predicting the motion of the proton between the plates, the gravitational field is not taken into consideration.

[4]

(c) Two point charges P and Q are placed 0.120 m apart as shown in Fig. 9.2.

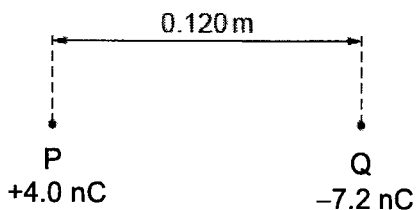

Fig. 9.2

(i) The charge at P is +4.0 nC and the charge at Q is -7.2 nC.

Determine the distance from P of the point on the line joining the two charges where the electric potential is zero.

distance = ..... m [2]

(ii) State and explain, without calculation, whether the electric field strength is zero at the same point at which the electric potential is zero.

.....  
 .....  
 ..... [2]

(iii) An electron is positioned at point X, equidistant from both P and Q, as shown in Fig. 9.3.

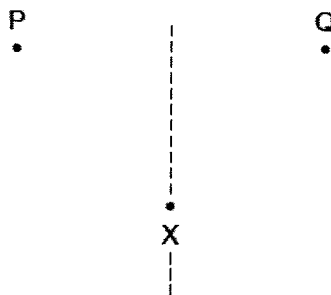

Fig. 9.3

On Fig. 9.3, draw an arrow to represent the direction of the resultant force acting on the electron. [1]

- (d) State the relationship between *gravitational potential* and *gravitational field strength*.

.....  
 ..... [1]

- (e) A moon of mass  $M$  and radius  $R$  orbits a planet of mass  $3M$  and radius  $2R$ . At a particular time, the distance between their centres is  $D$ , as shown in Fig. 9.4.

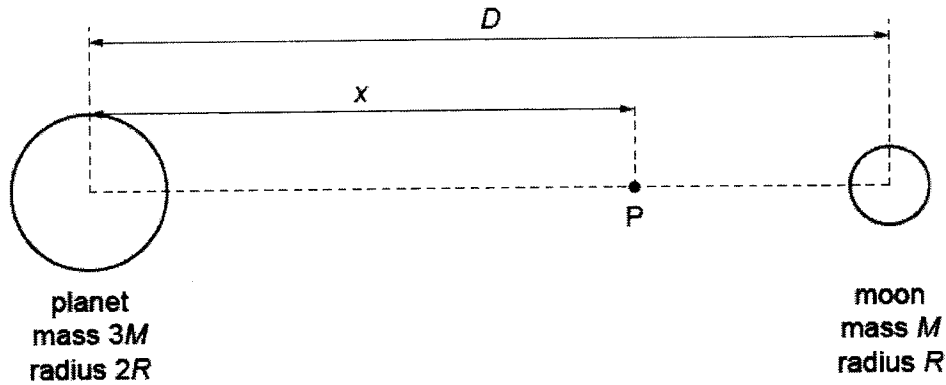

Fig. 9.4

Point  $P$  is a point along the line between the centres of the planet and the moon, at a variable distance  $x$  from the centre of the planet.

The variation with  $x$  of the gravitational potential  $\phi$  at point  $P$ , for points between the planet and the moon, is shown in Fig. 9.5.

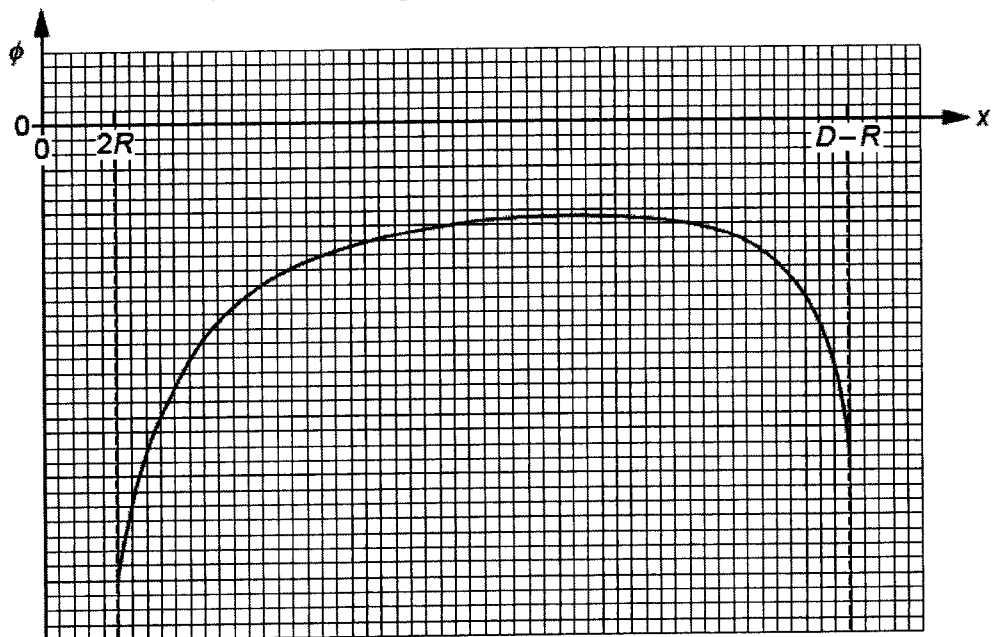

Fig. 9.5

(i) Explain why  $\phi$  is negative throughout the entire range  $x = 2R$  to  $x = D - R$ .

.....  
 .....  
 .....  
 ..... [3]

(ii) One of the features of Fig. 9.5 is that  $\phi$  is negative throughout. Describe two other features of Fig. 9.5.

1. ....  
 .....  
 2. ....  
 ..... [2]

(iii) On Fig. 9.6, sketch the variation with  $x$  of the gravitational field strength  $g$  at point P between  $x = 2R$  and  $x = D - R$ .

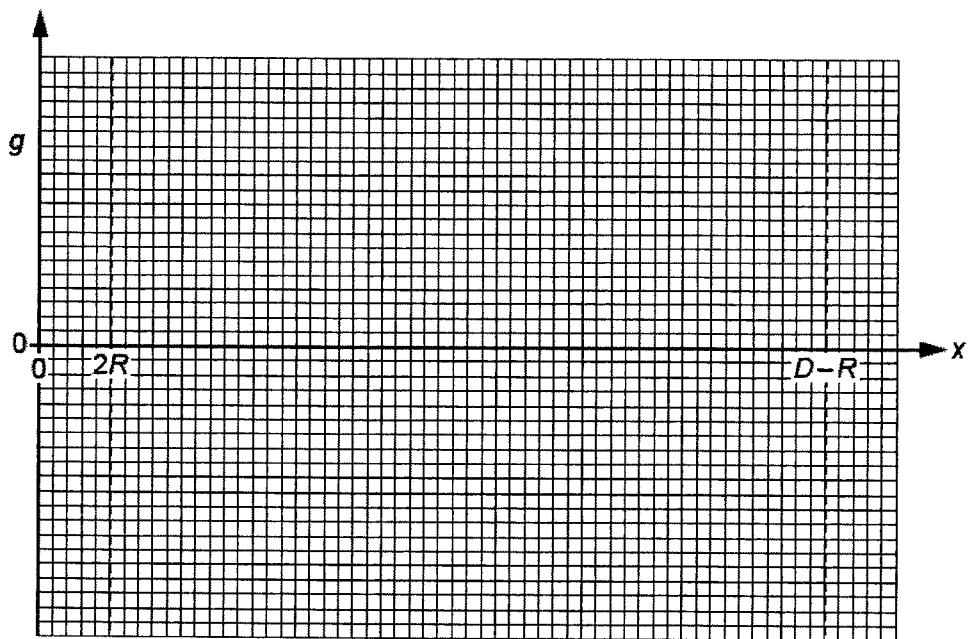

Fig. 9.6

[3]

[Total: 20]

**BLANK PAGE**

<b>Name:</b>		<b>Centre/Index Number:</b>		<b>Class:</b>	
--------------	--	-----------------------------	--	---------------	--



**DUNMAN HIGH SCHOOL**  
**Preliminary Examination**  
**Year 6**

**H2 PHYSICS**

Paper 4 Practical

**9749/04**

**22 August 2022**

**2 hours 30 minutes**

Candidates answer on the Question Paper

**READ THESE INSTRUCTIONS FIRST**

Write your centre number, index number, name and class at the top of this page.

Give details of the practical shift and laboratory where appropriate, in the boxes provided.

Write in dark blue or black pen.

You may use an HB pencil for any diagrams or graphs.

Do not use staples, paper clips, glue or correction fluid.

<b>Shift</b>	
<b>Laboratory</b>	

Answer **all** questions in the spaces provided on the question paper.

The use of an approved scientific calculator is expected, where appropriate.

You may lose marks if you do not show your working or if you do not use appropriate units.

At the end of the examination, fasten all your work securely together.

The number of marks is given in brackets [ ] at the end of each question or part question.

<b>For Examiner's Use</b>	
1	11
2	9
3	23
4	12
<b>Total</b>	<b>55</b>

This document consists of **19** printed pages and **1** blank page.

## 2

1 In this experiment, you will investigate an electrical circuit.

(a) Set up the circuit shown in Fig. 1.1.

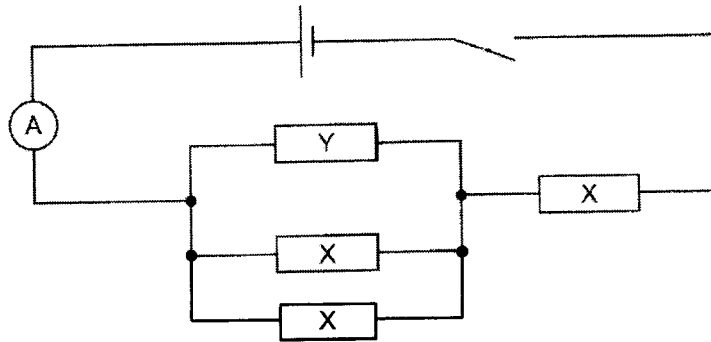

Fig. 1.1

The value of the resistance of Y is  $R_Y$ . Its value should be  $10\ \Omega$ .

Record  $R_Y$ .

$$R_Y = \dots\dots\dots$$

Close the switch.

Measure and record the ammeter reading  $I_1$ .

$$I_1 = \dots\dots\dots$$

Open the switch.

Change the positions of the resistors Y and X, as shown in Fig. 1.2.

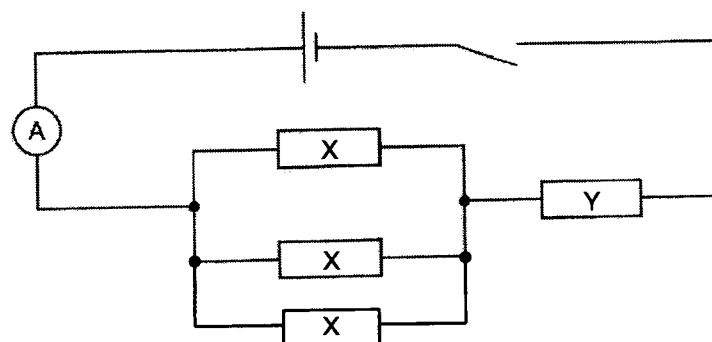

Fig. 1.2

Close the switch.

Measure and record the ammeter reading  $I_2$ .

$$I_2 = \dots\dots\dots$$

Open the switch.

[1]



- (b) Vary  $R_Y$ , and repeat (a).  
Present your results clearly.

[3]

- (c)  $I_1$ ,  $I_2$  and  $R_Y$  are related by the expression

$$\frac{I_1}{I_2} = \frac{2R_Y}{3R_X} + \frac{1}{3}$$

where  $R_X$  is the resistance of resistor X.

Plot a graph and use the gradient to determine  $R_X$ .

$R_X = \dots\dots\dots$  [5]

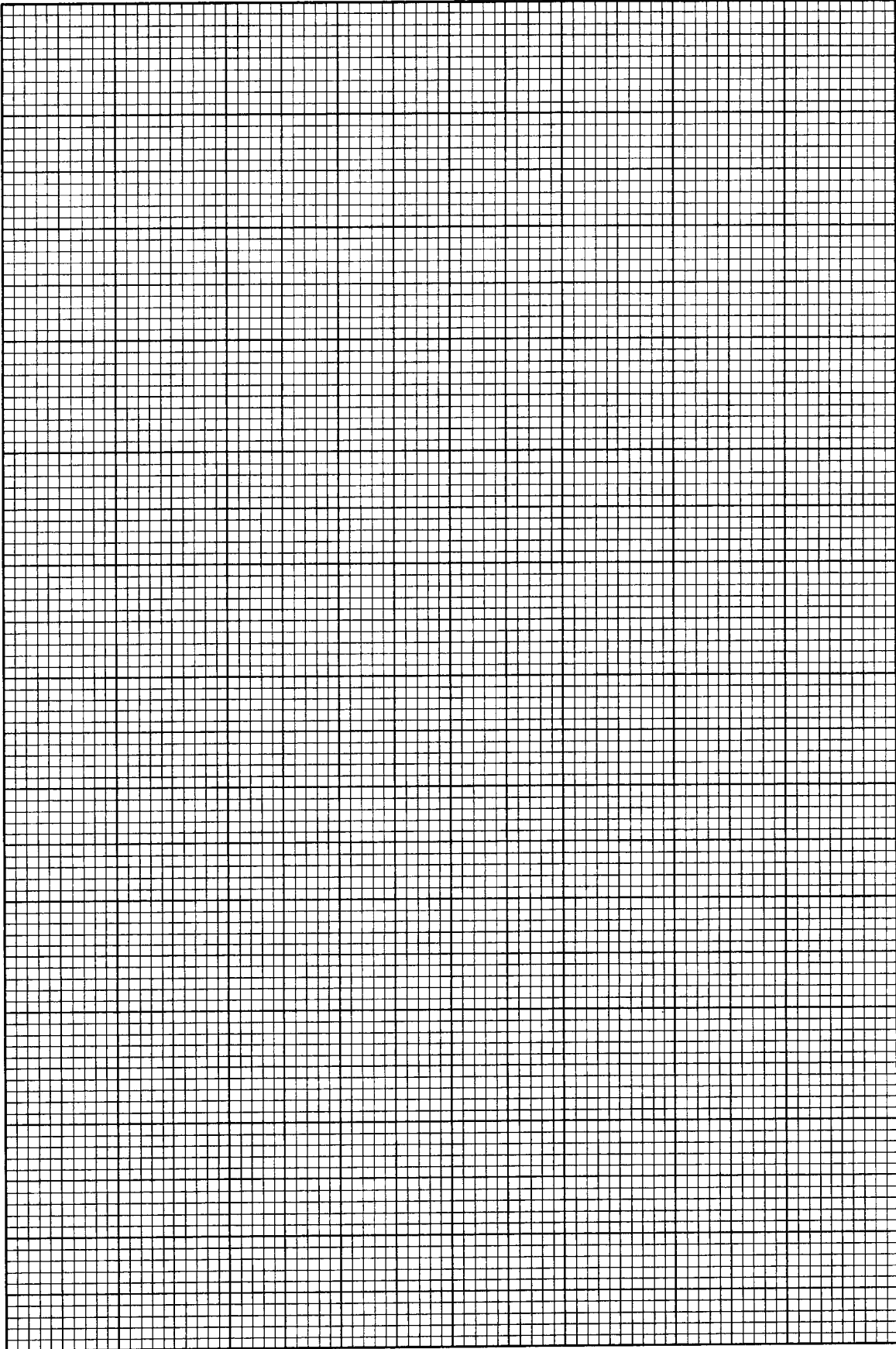

5

- (d) By considering the value of  $\frac{I_1}{I_2}$  when  $R_x = R_y$ , describe another way in which the graph can be used to determine  $R_x$ .

.....  
.....  
..... [1]

- (e) The experiment is repeated with a larger value of  $R_x$ .

Sketch a line on your graph grid on page 4 to show the expected result.

Label this line W.

[1]

**[Total: 11]**

2 In this experiment, you will investigate the centre of gravity of a suspended paper shape.

(a) You have been provided with a paper shape, as shown in Fig. 2.1.

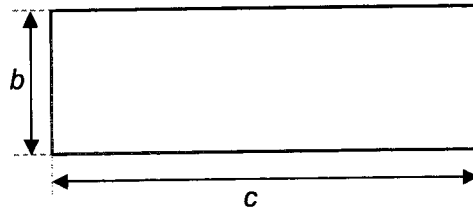

Fig. 2.1 (not to scale)

Measure and record the lengths  $b$  and  $c$ .

$b = \dots\dots\dots$

$c = \dots\dots\dots$

[1]

(b) Create the new paper shape, as shown in Fig. 2.2, by cutting out a rectangular paper shape.

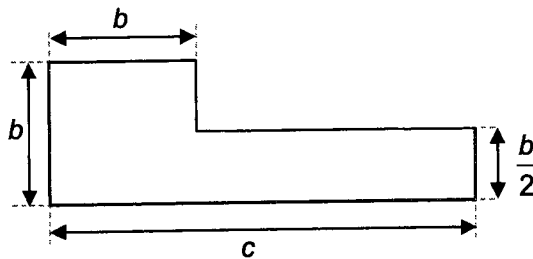

Fig. 2.2 (not to scale)

(c) Use the pin to make two small holes in the paper, as shown in Fig. 2.3.

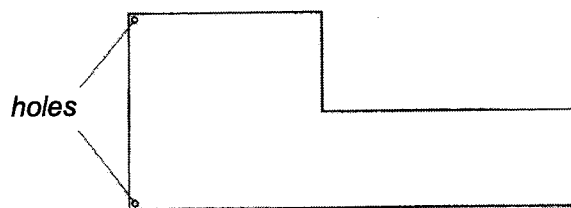

Fig. 2.3 (not to scale)

7

Suspend the paper as shown in Fig. 2.4. The pin should be held firmly in the clamp and the paper should hang freely. The loop of string at the end of the pendulum should be attached to the pin.

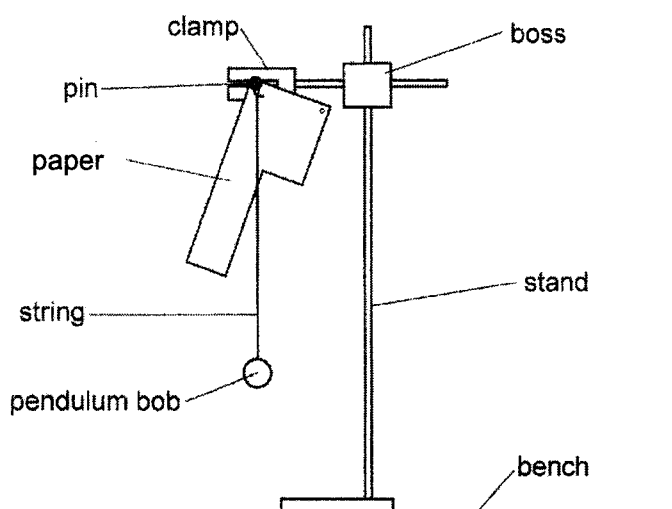

Fig. 2.4

Use the pencil to draw a line on the paper along the path of the string in Fig. 2.4, as shown in Fig. 2.5.

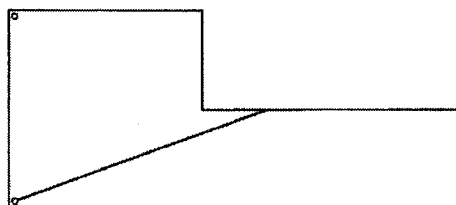

Fig. 2.5 (not to scale)

Repeat the procedure using the other hole in the paper. The two lines will cross at the centre of gravity  $G$ , a distance  $y$  above the longest edge of the paper, as shown in Fig. 2.6.

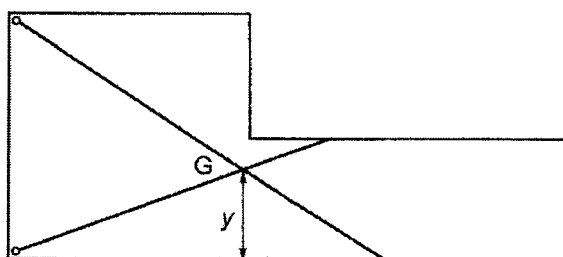

Fig. 2.6 (not to scale)

Measure and record  $y$ .

$y = \dots\dots\dots$  [1]

- (d) (i) Reduce  $c$  by 3 cm by cutting the paper at right angles to its edge where the holes are not present.

Measure and record  $c$ .

$c = \dots\dots\dots$  [1]

- (ii) Repeat the procedure from page 7.

$y = \dots\dots\dots$  [1]

- (e) Theory suggests that

$$y = \frac{b(3b + c)}{4(b + c)}$$

where  $b$  remains a constant.

- (i) Calculate the value of  $y$  when  $c$  is reduced by another 3 cm.

$y = \dots\dots\dots$  [1]

- (ii) The experiment is repeated for more values of  $c$ .  
State the graph to plot to obtain a straight line assuming that the theory is correct.

.....  
 .....  
 ..... [1]

- (iii) State expressions for the gradient and  $y$  - intercept of the line.

gradient = .....

$y$ -intercept = ..... [2]

- (f) Explain, without calculation, why the value of  $y$  is equal to 10.5 cm when  $c = b$ .

.....  
 .....  
 ..... [1]

**[Total: 9]**

3 A ride in a playground consists of a plank of wood supported by two loops of rope.

In this experiment, you will investigate a model of this ride.

You have been provided with two 1 m long strings and two half-metre rules.

(a) (i) Set up the apparatus as shown in Fig. 3.1.

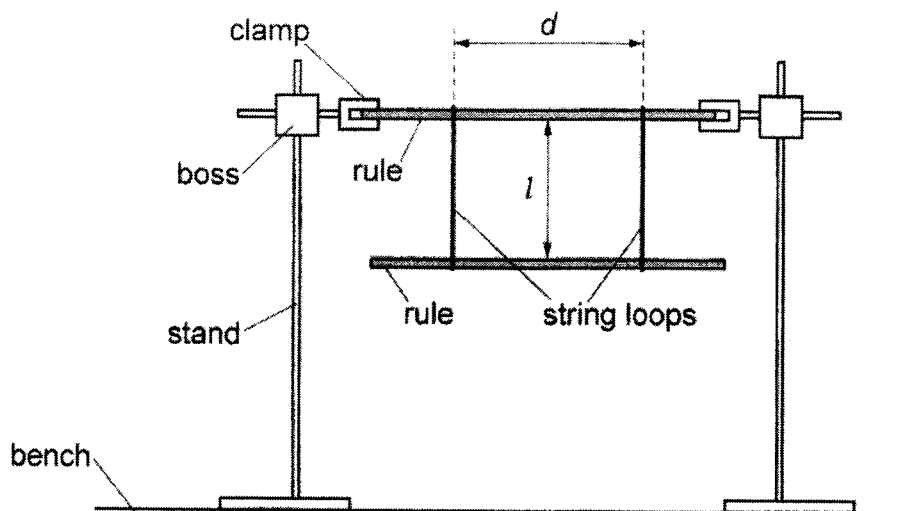

Fig. 3.1

Adjust the heights of the bosses until the top rule is parallel to the bench and both rules have their scales facing upwards.

The distance between the string loops is  $d$  and the distance between the bottom face of the top rule and the top face of the bottom rule is  $l$ .

Adjust the positions of the string loops until  $d$  is approximately 40 cm and  $l$  is approximately 30 cm.

The string loops should be vertical and the same distance from the centre of the bottom rule.

Measure and record  $d$ .

$d = \dots\dots\dots$  [1]

(ii) Estimate the percentage uncertainty in your value of  $d$ .

percentage uncertainty =  $\dots\dots\dots$  [1]

10

(iii) Measure and record  $l$ . $l = \dots\dots\dots$  [1](iv) Estimate the percentage uncertainty in your value of  $l$ .percentage uncertainty =  $\dots\dots\dots$  [1]

(b) Move one end of the bottom rule towards you.

Move the other end of the rule away from you.

Release the rule. The rule will oscillate about a vertical axis.

Determine the period  $T$  of the oscillations. $T = \dots\dots\dots$  [1](c) (i) Set up the apparatus using a value of  $l$  that is approximately 10 cm **larger** and a value of  $d$  that is approximately 10 cm **smaller**.

Repeat (a)(i), (a)(iii) and (b).

 $d = \dots\dots\dots$  $l = \dots\dots\dots$  $T = \dots\dots\dots$  [2](ii) Justify the number of significant figures you have given for your value of  $T$ .

.....

.....

..... [1]



(d) It is suggested that

$$T^2 d^2 = k l$$

where  $k$  is a constant.

(i) Use your values from (a)(i), (a)(iii), (b) and (c)(i) to determine two values of  $k$ .

Give your values of  $k$  to an appropriate number of significant figures.

first value of  $k$  = .....

second value of  $k$  = ..... [2]

(ii) State and explain whether the results of your experiment support the suggested relationship in (d).

Justify your conclusion by referring to your values in (a)(ii) and (a)(iv).

.....  
 .....  
 ..... [1]

(e) A value for the acceleration of free fall  $g$  near the surface of the Earth is given by

$$g = \frac{4\pi^2}{3k}(a^2 + b^2)$$

where  $b$  is the length of the half-metre rule and  
 $a$  is the width of the half-metre rule.

Use your second value of  $k$  to calculate a value for  $g$ .

$g$  = ..... m s<sup>-2</sup> [1]

(f) Using the **larger** value of  $l$ , add two 50 g masses to the bottom rule, as shown in Fig. 3.2.

Each mass represents a child on the ride.

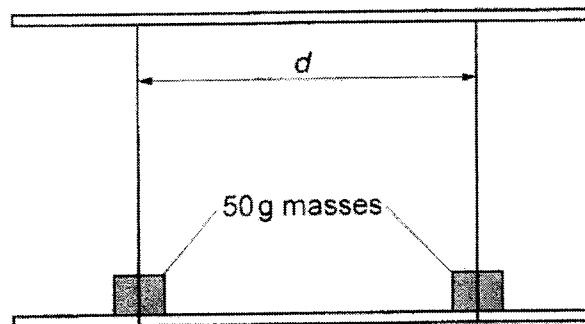

**Fig. 3.2**

Vary  $d$  and find values of  $T$  with and without the masses in place.

Present your results clearly.

Use your results to estimate a value for  $d$  where the value of  $T$  is the same with and without the masses.

$d = \dots\dots\dots$  [4]

13

- (g) You have been provided with some other masses. Use these masses to determine the effect on  $T$  of one or more children sitting at the **centre** of the ride while a child is seated at each string.

Present your results and conclusion clearly.

.....

.....

.....

..... [3]

- (h) The behaviour of the oscillating system depends on the length of the bottom plank. It is suggested that the period  $T$  is directly proportional to the length  $L$  of the plank.

Explain how you would investigate this relationship.

You may suggest the use of any additional apparatus commonly found in a school physics laboratory.

Your account should include:

- a diagram
- your experimental procedure
- control of variables
- how you would use your results to show direct proportionality

.....

.....

.....

.....

.....

.....

.....

.....

.....

.....

..... [4]

**[Total: 23]**

- 4 A circular coil P carrying an alternating current produces a changing magnetic field. When a second similar coil Q is placed with its centre a distance  $x$  from the centre of coil P, as shown in Fig. 4.1, an electromotive force (e.m.f.)  $E$  is induced in coil Q.

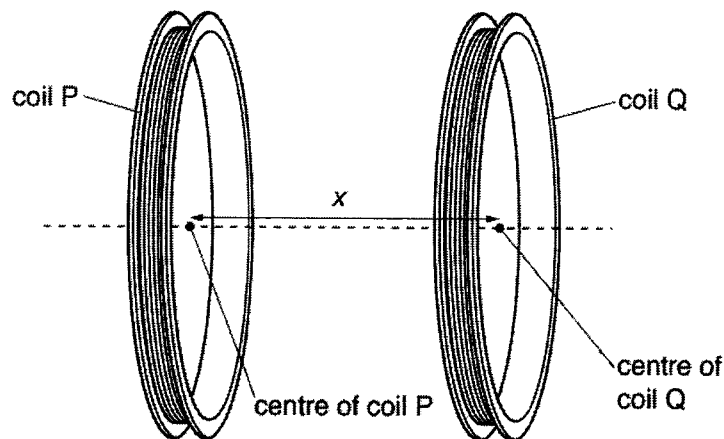

Fig. 4.1

It is suggested that  $E$  is related to  $x$  by the relationship

$$E = Ae^{-Bx}y^C$$

where  $y$  is the root-mean-square current in coil P and  $A$ ,  $B$  and  $C$  are constants.

Design a laboratory experiment to test the relationship among  $E$ ,  $x$  and  $y$ .

Explain how the results could be used to determine the values of  $A$ ,  $B$  and  $C$ .

Draw a diagram to show the arrangement of your apparatus. You should pay particular attention to

- the equipment you would use,
- the procedure to be followed,
- how the root-mean-square current in coil P is measured,
- the control of variables and
- any precautions that should be taken to improve the accuracy and safety of the experiment.

**Diagram**

.....

.....

.....

.....

.....

.....

.....

.....

.....

.....

.....

*(This section contains 25 horizontal dotted lines for writing.)*

Dotted lines for writing.





**BLANK PAGE**