

Index No.

--	--	--	--	--	--	--	--	--

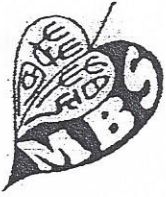

MAHA BODHI SCHOOL
2015 PRELIMINARY EXAMINATION
PRIMARY 6
SCIENCE
(BOOKLET A)

Name : _____ ()

Class : Primary 6 ()

Date : 18 August 2015

Total Duration for Booklets A and B : 1 h 45 min

INSTRUCTIONS TO CANDIDATES:

1. Write your Index No. in the boxes at the top right hand corner.
2. Do not turn over this page until you are told to do so.
3. Follow all instructions carefully.
4. Answer all questions.
5. Shade your answers in the Optical Answer Sheet (OAS) provided.

For each question from 1 to 30, four options are given. One of them is the correct answer. Make your choice and shade the oval (1, 2, 3 or 4) on the Optical Answer Sheet.

(60 marks)

1. Study the classification chart below.

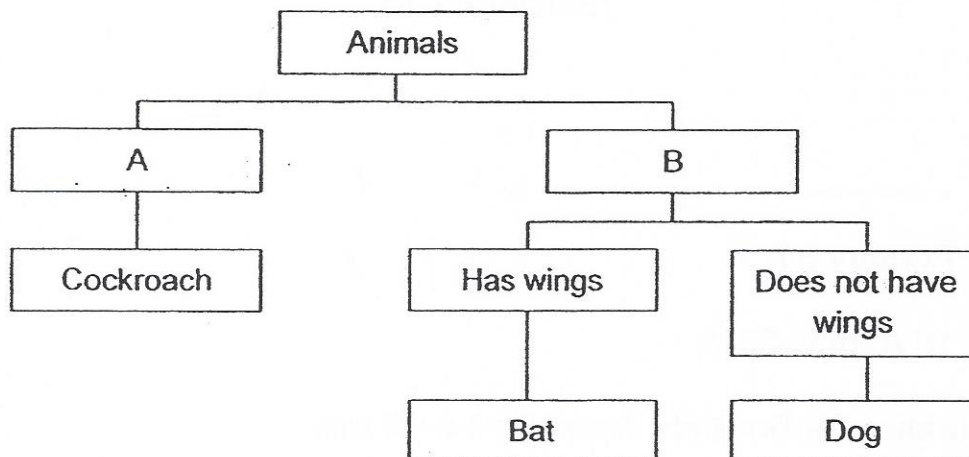

Which of the following represents A and B correctly?

	A	B
(1)	Lives on land	Lives in water
(2)	Has wings	Does not have wings
(3)	3-stage life cycle	4-stage life cycle
(4)	Does not have hair	Has hair

2. Which of the following statements is/are true of a frog and a grasshopper?

- A. The adult has wings.
- B. The adult has four legs.
- C. The young looks like the adult.
- D. They have three stages in their life cycles.

- (1) D only
- (2) A and C only
- (3) B and D only
- (4) B, C and D only

3. The diagram below shows a wind-pollinated flower.

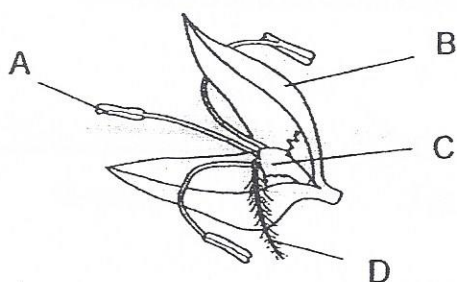

After Hazel transferred pollen grains onto one part of the flower, the flower developed into a fruit.

Which part of the flower, A, B, C or D, did she transfer the pollen grains to?

- (1) A
 - (2) B
 - (3) C
 - (4) D
4. Mun-Hee wanted to find out how the structure of a fruit would affect the time it stayed in the air. She made fruit models with different number of 'wings'. Each fruit model contained a marble to represent the seed. The diagram below shows one of the fruit models used.

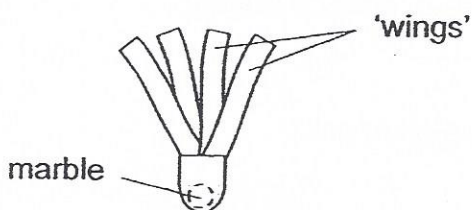

Which of the following variables should Mun-Hee keep the same to ensure a fair test?

- A. Number of 'wings'
 - B. Size and weight of the marble
 - C. Height at which the fruit model was dropped
 - D. Time taken by the fruit model to stay in the air
- (1) A and D only
 - (2) B and C only
 - (3) A, B and C only
 - (4) A, B, C and D

5. Varij conducted an experiment by placing the same number of seeds in two containers on his study room table as shown below.

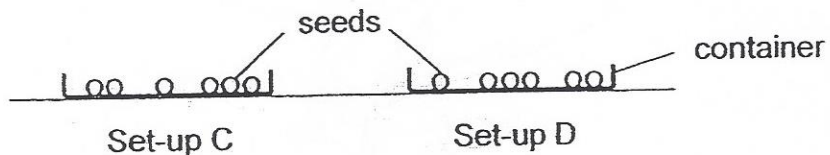

Varij did something to set-up C only.

The table below shows the results of his experiment after a few days.

	Number of seeds that developed roots	
	Set-up C	Set-up D
At the beginning	0	0
In the end	5	0

Which of the following had Varij done to set-up C?

- (1) Added water
 - (2) Blew a fan at the set-up
 - (3) Added some dry cotton wool
 - (4) Placed the set-up under a lit lamp
6. The diagram shows a plant cell.

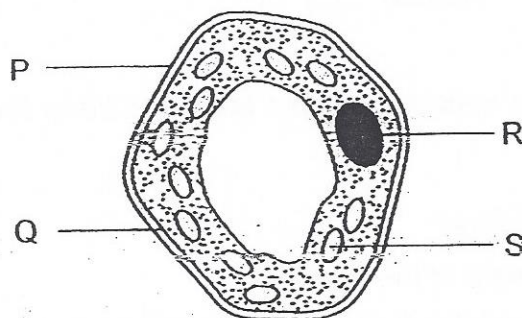

Which two parts are not found in animal cells?

- (1) P and Q
- (2) P and S
- (3) Q and R
- (4) R and S

7. The diagram below shows how blood flows in a fish.

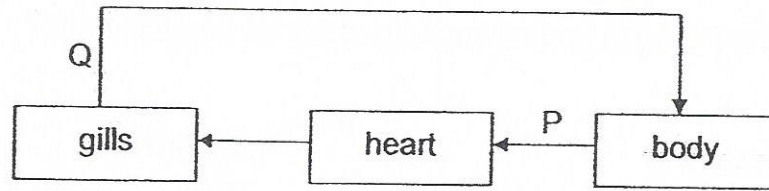

Which of the following is true?

	Blood in P	Blood in Q
(1)	Low in oxygen	Low in carbon dioxide
(2)	High in oxygen	Low in carbon dioxide
(3)	Low in oxygen	High in carbon dioxide
(4)	High in oxygen	High in carbon dioxide

8. Tom took a slow walk for 10 minutes. He then started running continuously for 20 minutes before resting.

Which of the following graphs correctly show his breathing rate?

(1)

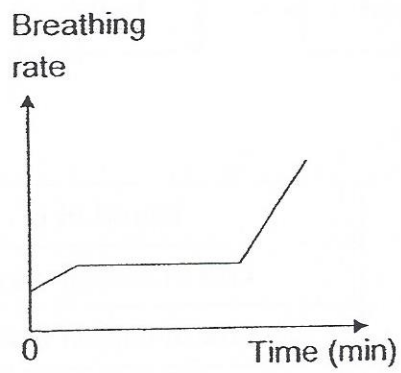

(2)

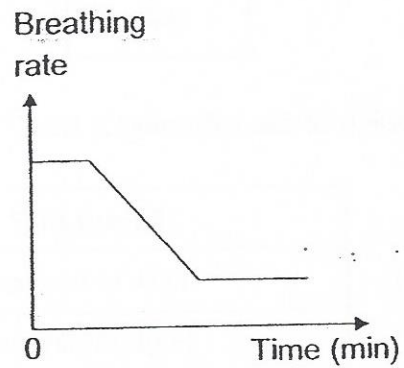

(3)

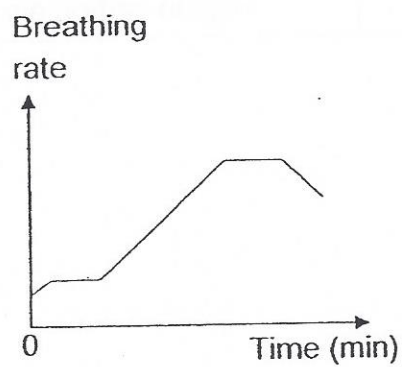

(4)

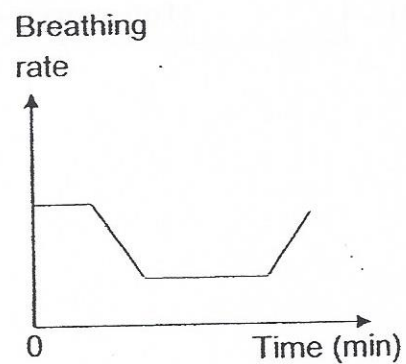

9. The graph below shows the number of organism V living in a river over a period of time.

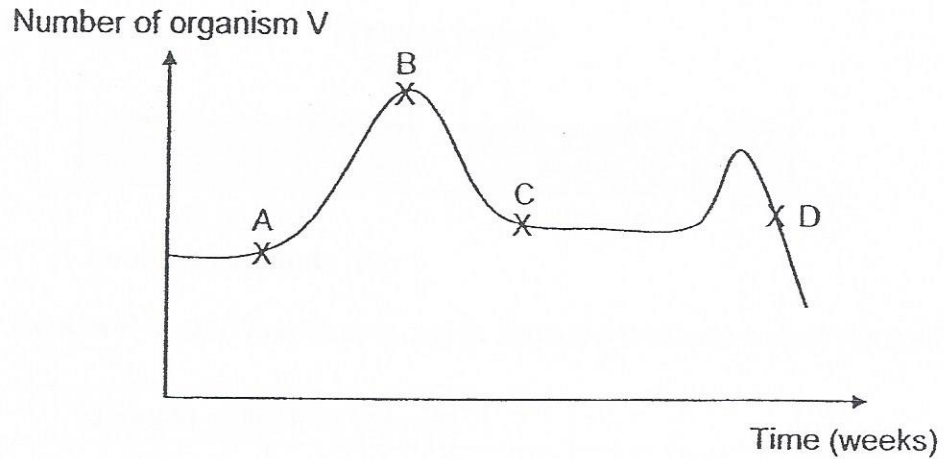

At which point of the graph was drought most likely to have started?

- (1) A
 - (2) B
 - (3) C
 - (4) D
10. The diagram below represents a food web of four populations living in the same habitat.

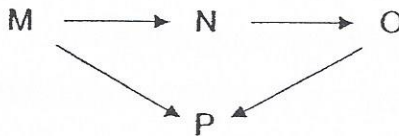

An animal skull as shown below was found in the same habitat.

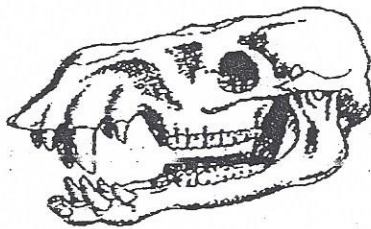

Based on the food web, which population would the skull most likely belong to?

- (1) M
- (2) N
- (3) O
- (4) P

11. Eshal carried out an experiment to find out how chemical X affected the growth of floating plants D as shown below.

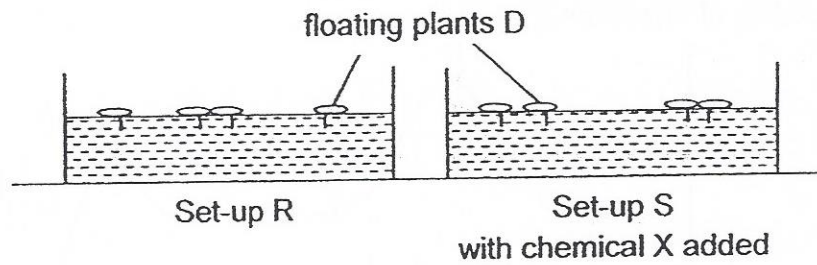

The table below shows the results of her experiment after a few days.

Set-up	Number of floating plants D	
	At the beginning	In the end
R	4	8
S	4	15

After the experiment, Eshal noticed floating plants D growing in a pond. There were also submerged plants growing in the same pond. A nearby factory discharged chemical X into the pond regularly. Chemical X had no effect on the submerged plants.

Based on the information above, infer how the characteristics of the pond water would change over time?

- A. Temperature of water would decrease
 - B. Amount of oxygen in the water would decrease
 - C. Amount of light entering the water would decrease
 - D. Amount of carbon dioxide in the water would decrease
- (1) A, B and C only
 (2) A, B and D only
 (3) B, C and D only
 (4) A, B, C and D

12. Tian Yang observed the relationships of five different populations, A, B, C, D and E, from the same community. He classified four populations in the table below. He was unable to classify population A into the table.

prey	prey and predator	predator
B, E	C	D

Which of the food webs would most likely represent the relationships between A, B, C, D and E in the community?

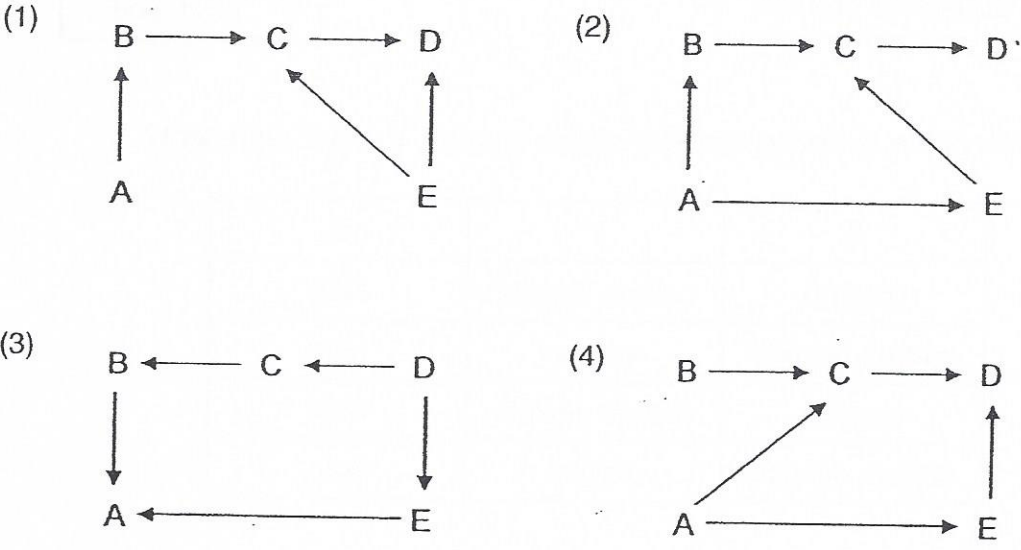

13. The diagram below shows what happens during photosynthesis.

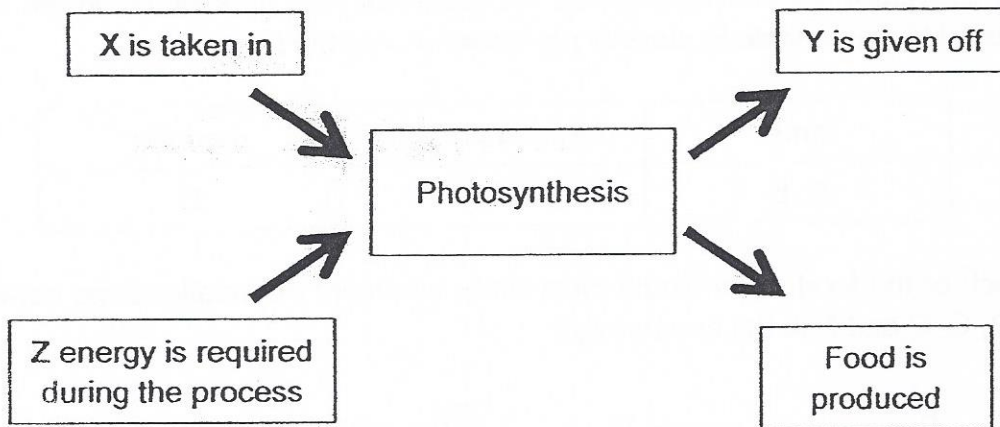

Which of the following correctly shows what X, Y and Z represent?

	X	Y	Z
(1)	oxygen	carbon dioxide	light
(2)	carbon dioxide	oxygen	heat
(3)	oxygen	carbon dioxide	heat
(4)	carbon dioxide	oxygen	light

14. Louis placed a water plant in a container of water and placed the set-up outdoors.

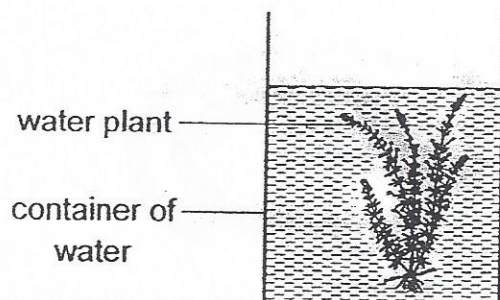

He took samples of the water at different times of the day and added a few drops of liquid Z to the water.

Liquid Z changes colour as shown below.

Amount of carbon dioxide in water	higher than normal	lower than normal
Colour of water with liquid Z	red	yellow

What colour would the water with liquid Z be for water samples taken at noon time and at midnight?

	At noon	At midnight
(1)	red	red
(2)	red	yellow
(3)	yellow	red
(4)	yellow	yellow

15. The picture shows a type of ruler that is able to measure the length of lines that are curved.

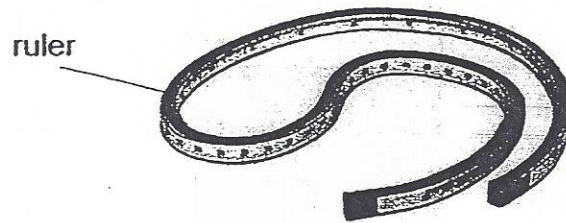

The ruler must be _____ in order to trace out different curved lines.

- (1) hard
 - (2) light
 - (3) flexible
 - (4) able to float on water
16. Mervyn and Santosh dropped their mobile phones on the beach. As they wiped off the sand, Mervyn noticed many scratches on his mobile phone screen and none on Santosh's mobile phone screen.

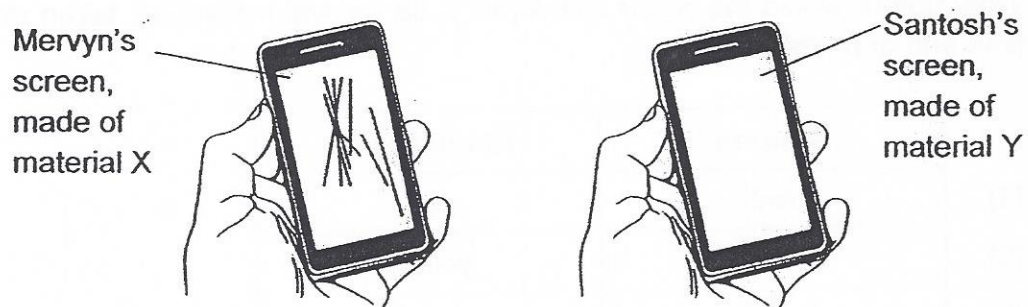

Based on the above information, which of the following statements are correct?

- A. Material X is harder than sand.
 - B. Material Y is harder than sand.
 - C. Material X is harder than material Y.
 - D. Material Y is harder than material X.
- (1) A and B only
 - (2) A and C only
 - (3) B and D only
 - (4) A, B and C only

17. The diagram below shows part of the water cycle.

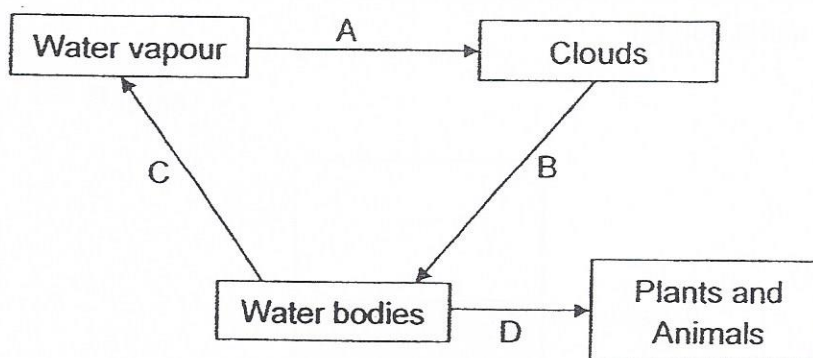

Which of the following correctly shows the change in state of water?

	A	B	C	D
(1)	No change	Gas to liquid	No change	Liquid to gas
(2)	No change	Gas to liquid	Liquid to gas	No change
(3)	Gas to liquid	No change	Liquid to gas	Liquid to gas
(4)	Gas to liquid	No change	Liquid to gas	No change

18. The table below shows the melting point and boiling point of two substances, L and M.

Substance	Melting Point (°C)	Boiling Point (°C)
L	5	250
M	20	520

Which of the following shows the correct state of substances L and M at 0°C and 400°C respectively?

	State of Substance L		State of Substance M	
	0°C	400°C	0°C	400°C
(1)	Solid	Liquid	Solid	Liquid
(2)	Solid	Gas	Solid	Liquid
(3)	Solid	Gas	Liquid	Gas
(4)	Liquid	Liquid	Liquid	Gas

19. A container has a capacity of 500 cm^3 . It contains 200 cm^3 of water and a 50 cm^3 solid cube as shown below. Another 30 cm^3 of air is pumped into the container using pump P.

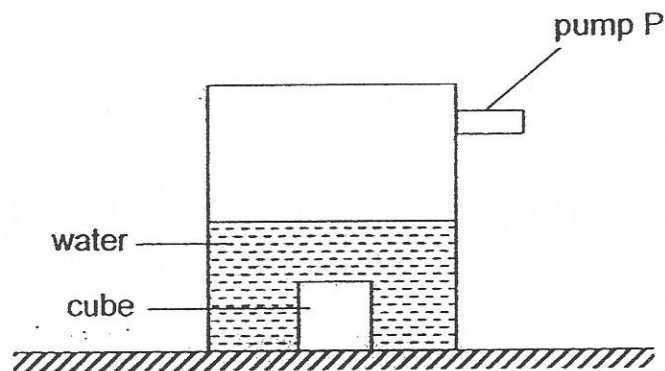

What is the final volume of air in the container?

- (1) 30 cm^3
 (2) 250 cm^3
 (3) 280 cm^3
 (4) 300 cm^3
20. Ifan sets up the two circuits below.

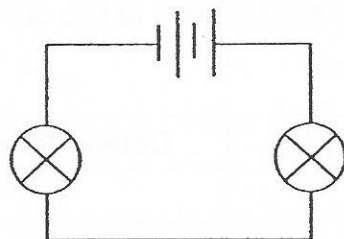

circuit A

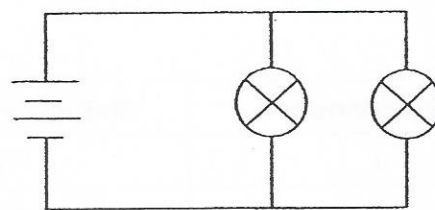

circuit B

Which of the following statements about the circuits are correct?

- A. The bulbs in circuit A are as bright as the bulbs in circuit B.
 B. The bulbs in circuit A are dimmer than the bulbs in circuit B.
 C. When one bulb blows in circuit A, the other bulb will not light up.
 D. When one bulb blows in circuit B, the other bulb will not light up.
- (1) A and C only
 (2) A and D only
 (3) B and C only
 (4) B and D only

21. Lu Yee set up the circuit as shown below.

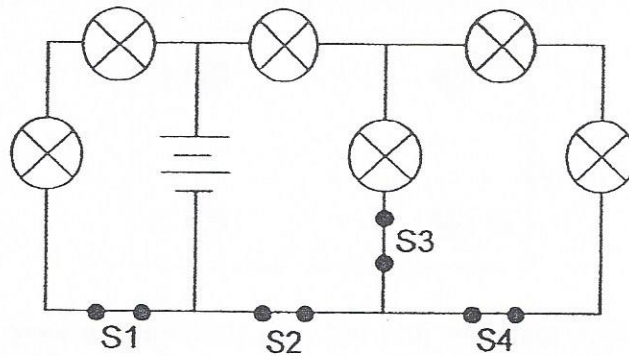

All six bulbs were lit when the switches were closed.

Which switch should she open if she wanted the fewest number of bulbs to be lit?

- (1) S1
- (2) S2
- (3) S3
- (4) S4

22. A balloon filled with air, was pushed downwards into a container of water as shown in Figure 1. Figure 2 shows the same balloon floating on water in the container after the hand was released.

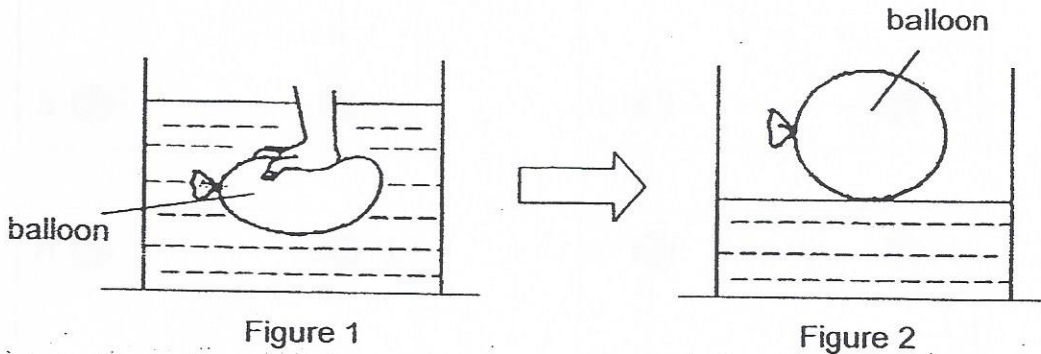

Which one of the following statements about the activity is true?

- (1) Magnetic force of repulsion was pushing the hand in Figure 1.
- (2) There was more friction between the balloon and the water in Figure 2 than that in Figure 1.
- (3) The balloon in Figure 2 exerted less force on the water than the balloon in Figure 1.
- (4) Less gravity acted on the balloon in Figure 1 than the balloon in Figure 2.

23. Melissa set up a circuit board with four metal buttons, P, Q, R and S, as shown. Wires were used to connect some of the buttons together under the board.

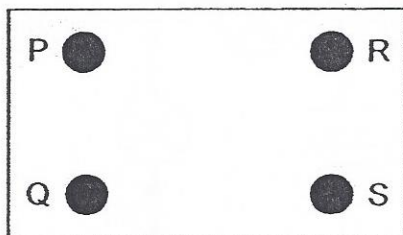

Melissa used a circuit tester to find out how the buttons were connected and recorded her results in the table below.

Buttons tested	Did the bulb light up?
P and Q	Yes
P and R	No
P and S	Yes
Q and R	No
Q and S	Yes
R and S	No

Which of the following are possible connections between the metal buttons?

A.

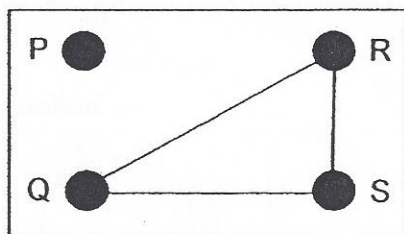

B.

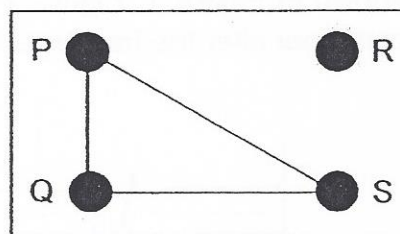

C.

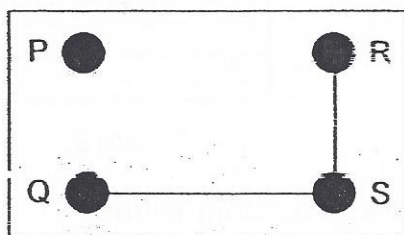

D.

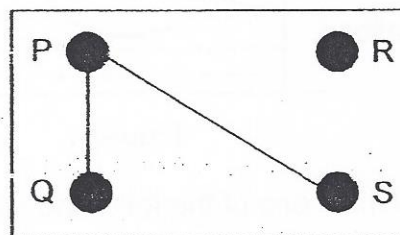

- (1) A only
 (2) B only
 (3) A and C only
 (4) B and D only

24. Felicia conducted an experiment. She attached a parachute of area $J \text{ cm}^2$ to a weight and dropped the set-up from a certain height. She recorded the time taken for the set-up to reach the ground.

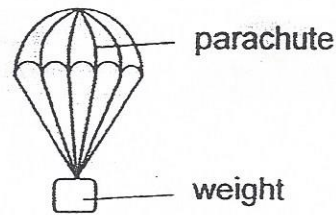

Felicia repeated the experiment with two parachutes of other areas, $K \text{ cm}^2$ and $L \text{ cm}^2$. She used the same weight and dropped it from the same height. Her results are shown in the table below.

Area of parachute (cm^2)	J	K	L
Time taken to reach the ground (s)	6	2	10

Based on her results, which area of parachute should she choose (from best to worst) to slow down her moving toy plane?

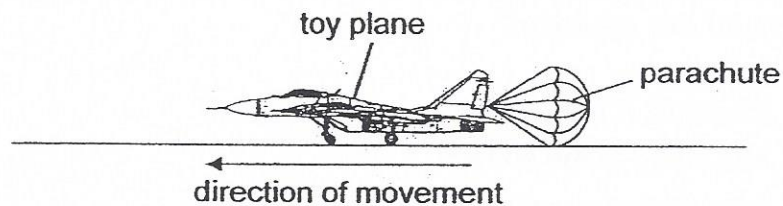

	best choice	→	worst choice
(1)	J		L
(2)	K		L
(3)	K		J
(4)	L		K

25. A bar magnet was taped onto the top of toy car X. Object Z was taped onto the top of another similar toy car Y as shown in Diagram 1.

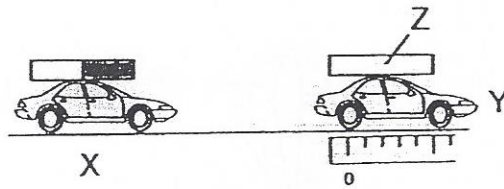

Diagram 1

Car X was pushed towards car Y. When car X went very near to car Y, car Y started moving and travelled about 5 cm as shown in Diagram 2.

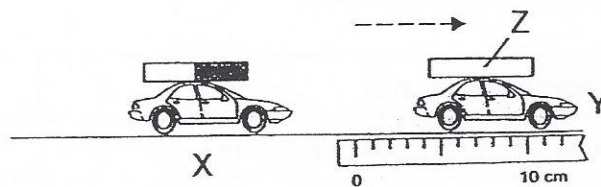
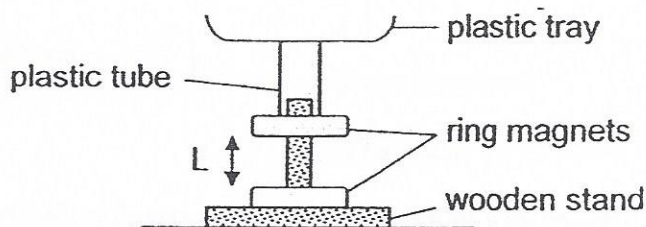

Diagram 2

Which of the following actions would make car Y move further than 5 cm when the experiment was repeated?

- A. Hit object Z many time
 - B. Add water to the surface
 - C. Turn the bar magnet around
 - D. Use similar but heavier cars X and Y
- (1) B only
- (2) A and D only
- (3) B and C only
- (4) A, C and D only

26. Muthu uses the following set-up in an experiment.



He places stones, each of a different mass onto the tray and measures length L . The results are shown in the table below.

Stones placed on tray	Length L (cm)
P	1.0
Q	3.0
Q and R	2.0

Based on Muthu's results, which of the following is a possible value of length L when only stone R is placed onto the tray?

- (1) Less than 1 cm
- (2) Between 1 cm and 2 cm
- (3) Exactly 2 cm
- (4) More than 3 cm

27. A wind-up toy, at point A was moving forward until it stopped at point B.

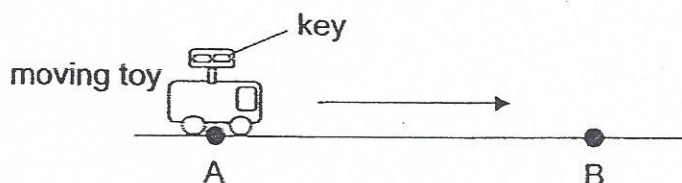

Compare the potential energy and kinetic energy of the toy at points A and B. Which one of the following is correct?

	potential energy at B compared to A	kinetic energy at B compared to A
(1)	less	less
(2)	less	more
(3)	more	less
(4)	more	more

28. Simon placed an ice cube at one end of material S. He measured the time taken for the temperature of the other end of material S to drop by 5°C.

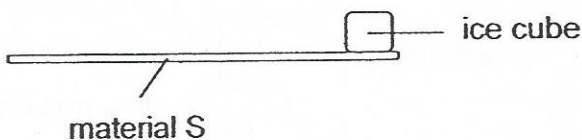

He repeated the experiment using material T. His results are shown in the table below.

Material	Time taken (min)
S	10
T	35

Simon wanted to pack hot food and cold drinks for lunch in containers. The containers should be able to keep the food hot and the drinks cold.

Which material(s) would be more suitable for the containers?

Material for container carrying	
hot food	cold drinks
(1) S	S
(2) S	T
(3) T	S
(4) T	T

29. Study the set-up below. Lamps J and K are identical and each lamp gives out the same amount of light when it is lit.

D, E and F represent three sections of a wall.

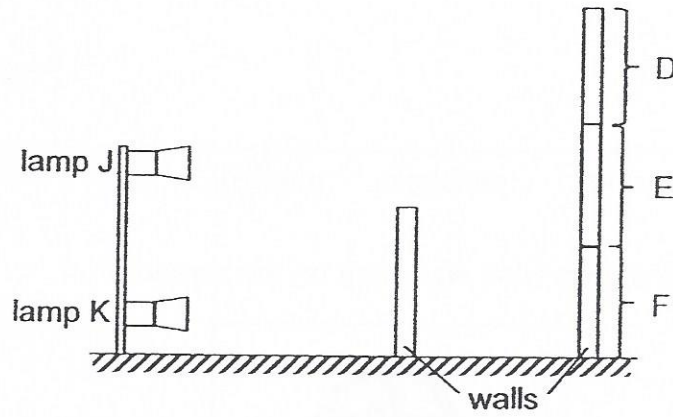

If only lamp K is lit, only section D receives light.

If both lamps J and K are lit, which one of the following shows the correct order of increasing amount of light received for sections, D, E and F?

Amount of light received by sections		
Least	→	Most
(1) E	F	D
(2) F	E	D
(3) F	D	E
(4) D	E	F

30. Benny conducted an experiment using a torch and three shapes, a ring, a rectangle and a triangle made of cardboard. They were placed at different positions away from the torch.

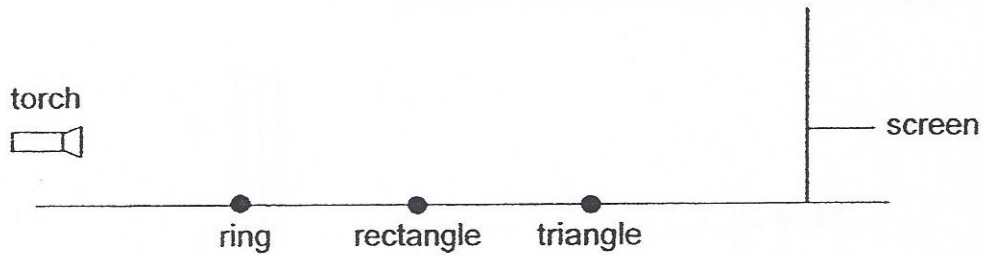

The diagram below shows what was seen on the screen.

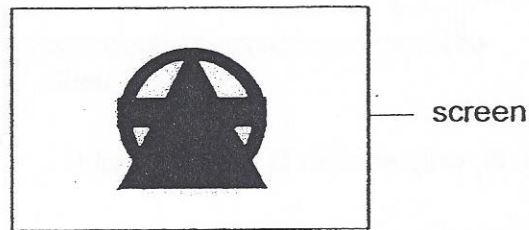

Benny used a rectangle cardboard of length 10 cm.

Which of the following shows correctly the diameter of the ring and the base of the triangle cardboards?

	Diameter of ring	Base of triangle
(1)	10 cm	10 cm
(2)	Shorter than 10 cm	10 cm
(3)	Shorter than 10 cm	Longer than 10 cm
(4)	Longer than 10 cm	Shorter than 10 cm

END OF BOOKLET A

GO ON TO BOOKLET B

Index No.

--	--	--	--	--	--	--	--

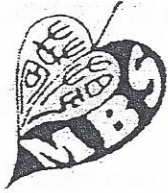

MAHA BODHI SCHOOL
2015 PRELIMINARY EXAMINATION
PRIMARY 6
SCIENCE
(BOOKLET B)

Name : _____ ()

Class : Primary 6 ()

Date : 18 August 2015

Total Duration for Booklets A and B : 1 h 45 min

INSTRUCTIONS TO CANDIDATES:

1. Write your Index No. in the boxes at the top right hand corner.
2. Do not turn over this page until you are told to do so.
3. Follow all instructions carefully.
4. Answer all questions.
5. Write all your answers in this booklet.

Booklet	Marks Obtained	Max Marks
A		60
B		40
Total		100

For questions 31 to 44, write your answers in this booklet.

The number of marks available is shown in the brackets [] at the end of each question or part-question.

(40 marks)

31. Luther applied an increasing amount of force on material W. He recorded the amount of force needed to break the material. He repeated the experiment with materials X, Y and Z.

He recorded his results in the table below.

Material	Colour of material	Thickness of material (mm)	Force needed to break material (unit)
W	Red	10	100
X	Blue	11	150
Y	Yellow	12	200
Z	White	13	200

- (a) What property of the materials was being tested? [1]

- (b) One of the variables in the test above made this an unfair test. Which variable made this test unfair? [1]

- (c) Luther wanted to test the relationship between the variable in (b) and the amount of force needed to break the material.

What changes to the experiment should Luther make? [1]

Marks :

/ 3

32. Devi observed how the size of seeds of plant Z affected the distances they were away from their parent plants. She plotted her results as shown below.

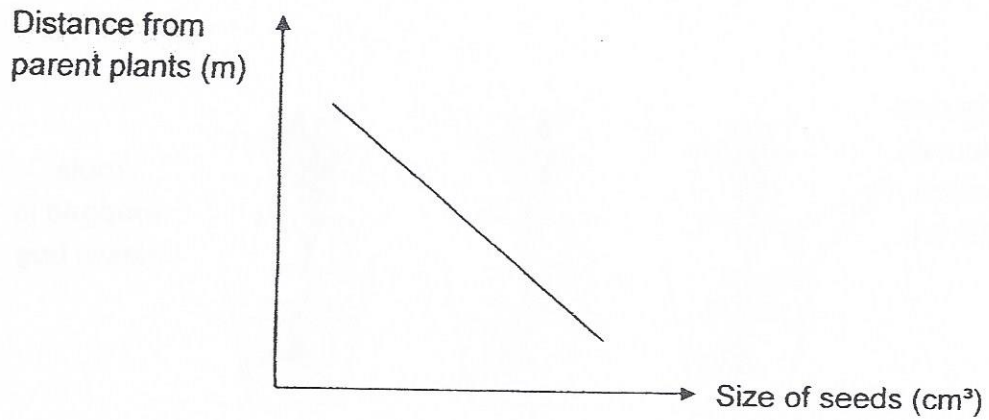

- (a) Based on her results, what could Devi conclude about the size of seeds and the distance they were away from parent plants? [1]

- (b) State one benefit for plant Z when the seeds are smaller in size. [1]

- (c) After germination, Devi observed that bigger seeds could survive for a longer period of time without light. Give a reason for Devi's observation. [1]

Marks :

/ 3

33. Three plants were placed in similar containers of water containing the same amount of water as shown below.

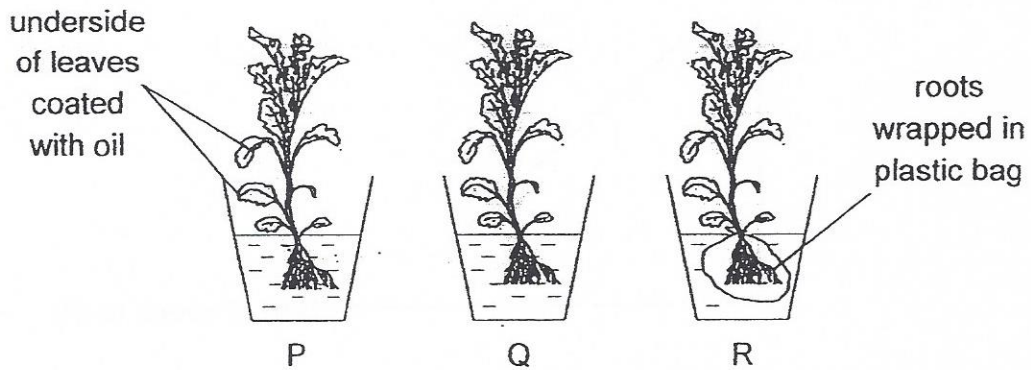

The amount of water left in each container was measured after three days.

- (a) In which set-up would there be the most amount of water left? Explain your answer. [1]

- (b) In which set-up would there be the least amount of water left? Explain your answer. [1]

Marks :

12

34. Joshua wanted to test how the amount of light affects the length of the stem of bean plants.

He planted five seeds in each of the three pots of soil and placed them under lamps of different light intensity. The diagram below shows one of the set-ups.

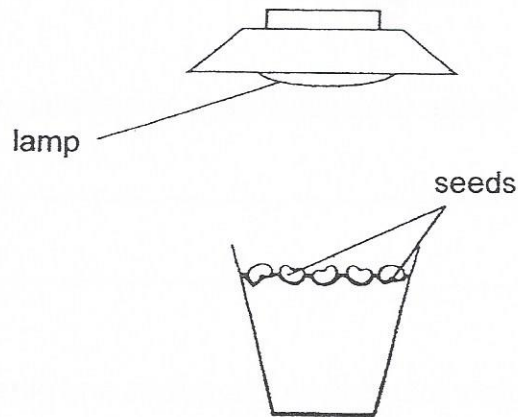

After a period of time, he measured the length of the stems of the bean plants and recorded his results as shown in the table below.

Pot	Amount of light (units)	Average length of stem (cm)
A	26	5.9
B	560	4.1
C	4285	3.5

(a) How did the amount of light affect the length of the stem? [1]

(b) Explain the relationship between the length of stem and amount of light in (a). [1]

(c) Four weeks after germination, only the plants in pot A died even though they were watered regularly. Explain why the plants died. [1]

Marks : / 3

35. Insect S is usually found on the underside of leaves. One of its predators is birds.



(a) Explain how this behaviour of insect S helps to enhance its survival? [1]

Adults of insect S are predators that feed on caterpillars and other insects. These adults are observed to stay in groups.

(b) How does staying in groups help adults of insect S to obtain food? [1]

Marks :

12

36. (a) Rizwan used two containers, F and G, to pack his piping hot rice as shown below.

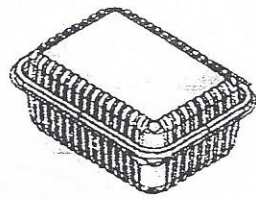

container F

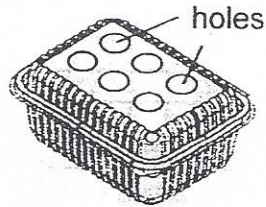

container G

After packing, he closed both containers and left them untouched on his kitchen table.

- (i) Rizwan observed that the rice in container G became cooler than the rice in container F after some time. Give a reason for his observation. [1]

- (ii) Rizwan also observed that water droplets were formed on the inside of container F after some time. Give a reason for the formation of the water droplets. [1]

Marks :

12

- (b) In dry and cold places, farmers practice tunnel farming by covering parts of their land with plastic sheets as shown in the diagram below.

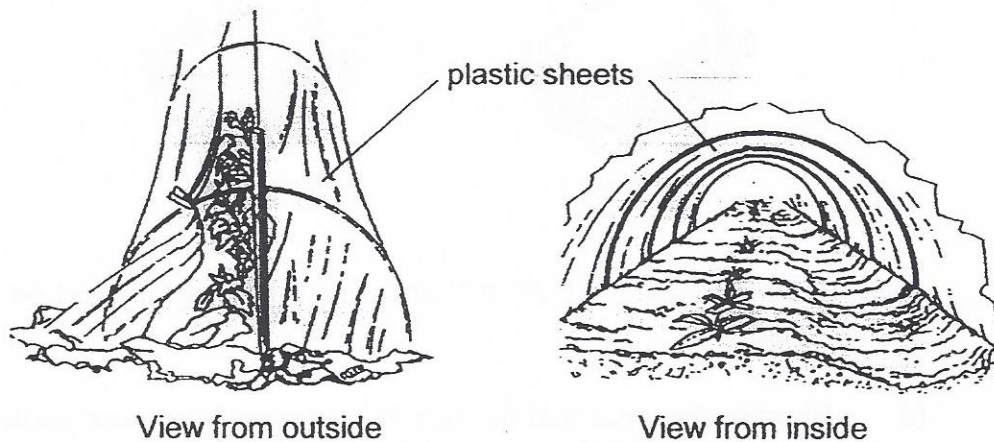

By using this farming method, seeds take a shorter time to germinate.

Suggest two reasons why the use of the plastic sheets as covers can help the seeds to germinate earlier. [2]

Reason 1:

Reason 2:

Marks :

12

37. The plant below stores food in parts of the stem underground as shown below.

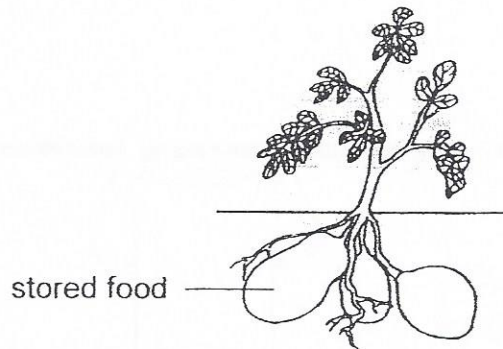

The food is farmed and eaten by people.

- (a) Explain how the food is made and stored in the parts of the stem underground. [1]

- (b) At one farm, the farmers grow the plants in an area with a higher level of carbon dioxide in the air.

With all other conditions being the same, will the amount of food obtained from the plants over the same period be more, less, or the same? Explain your answer. [2]

Marks :

13

38. Sam wanted to test how the way a wet shirt is hung will affect the time it takes to dry. Two similar shirts were hung on a pole in the sun after washing as shown below.

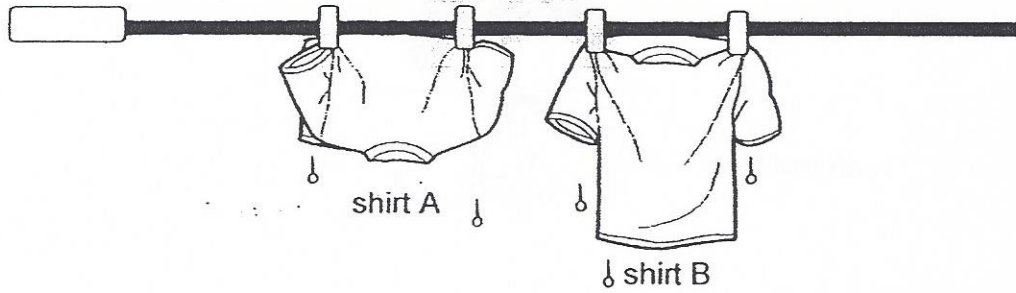

- (a) Which shirt would dry faster? Explain your answer. [1]

- (b) Explain how hanging the shirts at the same location make this a fair test? [1]

Marks :

12

39. (a) The diagram below shows two similar empty glass dishes, X and Y. Dish X was placed in a refrigerator while dish Y was placed in an oven.

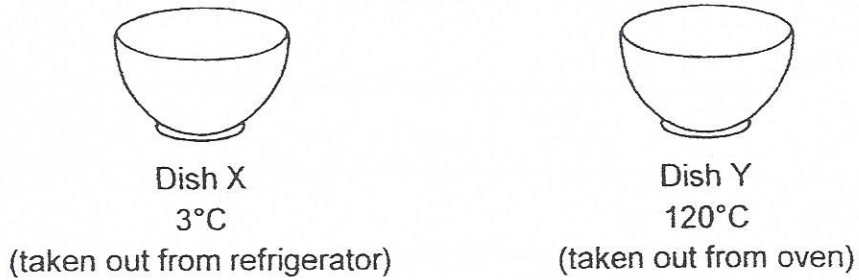

After one hour, both dishes were removed from the refrigerator and oven respectively, and placed on a table in a room of 30°C.

On which one of the dishes, X or Y, would water droplets be observed after some time? Explain your answer. [1]

- (b) Sharon was driving when it started to rain. She noticed a layer of mist forming on the inner windscreen of her car.

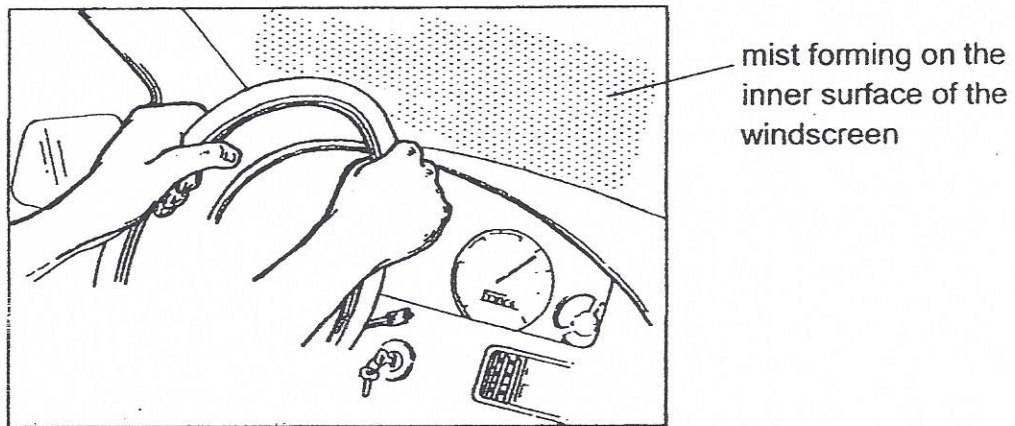

- (i) What could Sharon infer about the temperatures inside and outside her car? [1]

Marks :

12

- (ii) Sharon decided to increase the fan speed of the air-conditioner in her car. Based on your answer in (i), explain how this would help to stop more mist from forming on the windscreen. [2]

Marks :

12

40. In a quiz show between two contestants, the contestant who wants to answer a question first has to close his switch first.

The two circuits, one for each contestant, are shown below.

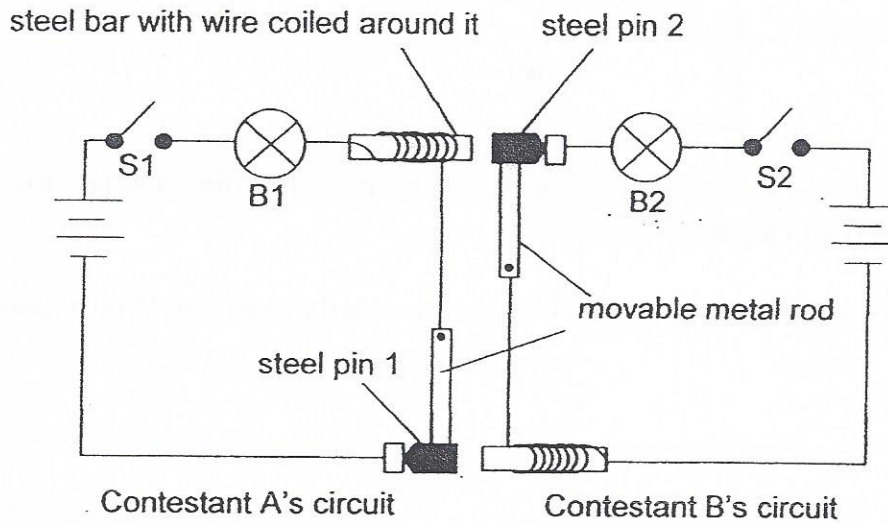

Each circuit consists of a movable metal rod fixed to one end to the circuit. The other end of the rod is attached to a steel pin which is not fixed to the circuit. The wire of each circuit is coiled around a steel bar. When both switches are open, a spring mechanism (not shown in the diagram) moves the metal rods to their original position.

- (a) What happens to the bulbs if only S2 is closed? [1]

- (b) For a particular question, Contestant A closes his switch before Contestant B.

When Contestant B closes his switch, will B2 light up? Explain your answer. [2]

Marks :

1/3

41. Jae Woo placed a block on a slope as shown in the diagram below.

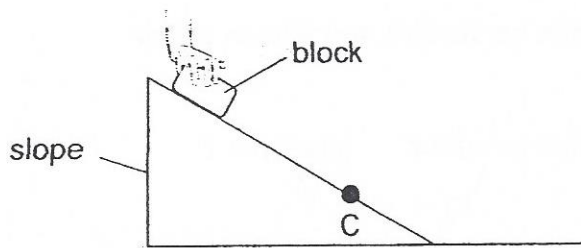

When Jae Woo released the block, it slid downwards. After a while, the block slowed down and stopped at point C.

- (a) Give a reason why the block slid downwards after Jae Woo released it. [1]

Jae Woo repeated the activity using another similar-sized block made of a different material. After the block was released, it slid and stopped before point C.

- (b) Jae Woo concluded that the two blocks stopped moving because there were no forces were acting on the blocks.
Give two reasons why he could not make such a conclusion. [2]

Reason 1: _____

Reason 2: _____

Marks :

13

42. Hsiao Chi conducted an experiment using the set-up shown below.

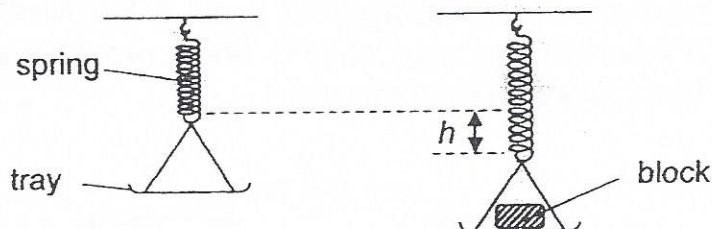

She measured length h after the block was placed on the tray. She repeated the experiment using blocks of various mass and volumes. Her results are shown below.

Block	Mass (g)	Volume (cm ³)	h (cm)
X	25	80	0.5
Y	75	80	1.5
Z	75	100	1.5

- (a) Based on Hsiao Chi's results, did the volume of the block affect the amount of force acting on the spring? Explain how you came to your conclusion. [1]

- (b) Hsiao Chi repeated the same experiment using another block W. The mass of W was 25 g and its volume was 100 cm³. What could the value of h be? [1]

- (c) At the end of the experiment, the tray was emptied. Hsiao Chi observed that h was 0 cm. Based on this observation, state the property of the spring. [1]

Marks :

13

43. Aminah conducted an experiment using set-ups P and Q, as shown below. The containers were made of different materials, X and Y. She filled both containers with the same volumes of hot water at 80°C. She sprayed the same amount of water on the outer surface of each container.

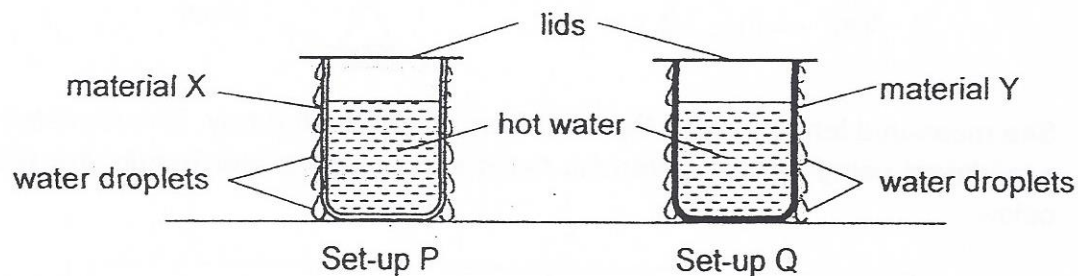

Aminah measured the time taken for all the water droplets to disappear from the outer surfaces of the containers. Her results are shown in the table below.

Set-up	Time taken (min)
P	3
Q	9

- (a) Aminah observed that the temperatures of the hot water in both containers were decreasing as water droplets disappeared from the outer surfaces of the containers. Explain Aminah's observation. [1]

- (b) Based Aminah's results, what could she conclude about the property of materials X and Y? [1]

Marks :

12

44. Li Xue made a pinball game and placed it flat on a table. The diagram shows the top view of the game board she made.

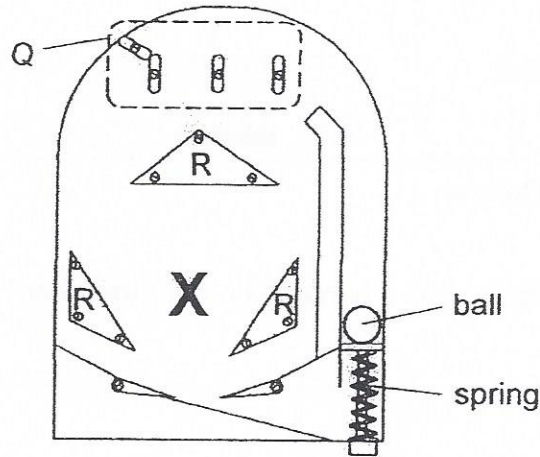

- (a) To begin the game, Li Xue had to first compress and then release the spring so that the ball could start to move. Based on the information, show the energy conversion by filling each box with the correct form of energy. [1]

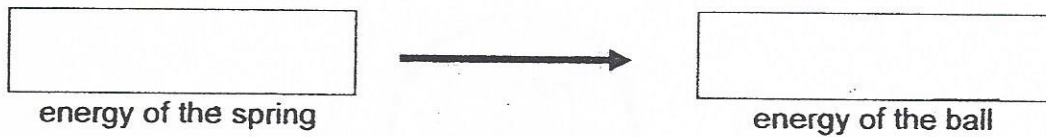

- (b) As the ball moved, it hit a few structures Q and R. The ball then moved slower. Explain why the ball moved slower after hitting structures Q and R. [1]

Marks :

12

- (c) The ball eventually came to a stop at position X. Li Xue tilted the board at an angle and the ball moved out of position X.

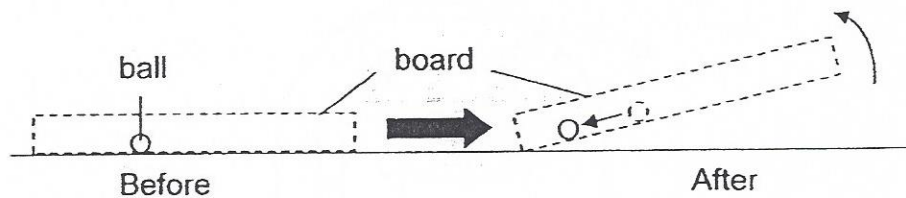

Explain why the ball moved again after the board was tilted. [1]

~ END OF PAPER ~



Marks :

/ 1

EXAM PAPER 2015**LEVEL : PRIMARY 6****SCHOOL : MAHA BODHI SCHOOL****SUBJECT : SCIENCE****TERM : PRELIMINARY EXAMINATION****BOOKLET A**

Q 1	Q 2	Q 3	Q 4	Q 5	Q 6	Q 7	Q 8	Q 9	Q 10
4	1	4	2	1	2	1	3	2	4
Q 11	Q 12	Q 13	Q 14	Q 15	Q 16	Q 17	Q 18	Q 19	Q 20
1	2	4	3	3	3	4	2	2	3
Q 21	Q 22	Q 23	Q 24	Q 25	Q 26	Q 27	Q 28	Q 29	Q 30
2	3	4	4	1	4	1	4	2	3

- Q31a. The material's strength. Q31b. Thickness of the material Q31c. Luther should make the thickness of the different material the same.
- Q32a. The larger the size of the seeds, the shorter the distance from the parent plants.
- Q32b. Smaller seeds will be dispersed farther from their parent plants, when the seeds are smaller in size, the distance from parent plants is further which would prevent competition with parent plant for air, water, nutrients and sunlight.
- Q32c. The bigger seeds contain more nutrients and could survive longer without light compared to the smaller seeds.
- Q33a. Set up R. The roots of the plant are wrapped in the plastic bag, the roots will not be able to take in water and there would be the most amount of water left.
- Q33b. Set up Q. The roots could still take in water and lose more water through their stomata.
- Q34a. The length of the stem was shorter when there is more light.
- Q34b. When there is less light, the plant has to grow taller to get more light.
- Q34c. There was not enough light for the plants to make food.
- Q35a. Staying in groups enables insects to co-operate in their attack and increase their chances of killing a bigger prey.
- Q35b. When it hides on the underside of leaves, the predator would not be able to spot it.
- Q36ai) The heat in container G could escape through the holes in container G.
- Q36aii) Heat can escape G through the holes.
- Q36b. Reason 1 : The heat will be trapped inside and there would be enough warmth for the plants to grow. Q36b. Reason 2 : The water evaporates and condenses on the inner surface of the plastic sheet,
- Q37a. The leaves take in sunlight and makes food, the food - carrying tubes will then carry the food to all parts of the body and the extra food will be stored in the stem.
- Q37b. More. More carbon dioxide will be taken in by the plant, photosynthesis will happen at a faster rate and more food will be stored at the stem.
- Q38a. B has a larger ESA so water evaporate faster.
- Q38b. Small location means wind and heat and temperature.
- Q39a. Dish X. The surrounding water vapor will condense on the cooler outer surface of dish X.
- Q39b i) The temperature inside her car is higher than the temperature outside.
- Q39b ii) The temperature inside her car would be lower and the water vapour in her car would not condense on the inner surface of the windscreen.
- Q40a. Bulb B2 would light up while Bulb B1 would not light up.
- Q40b. No. There will be not be a closed circuit for the current to flow through and B2 will not light up.
- Q41a. Gravity is acting on the block.
- Q41b. Reason 1 : No answers available.
- Q41b. Reason 2 : The blocks stopped before it reached the ground because friction is acting on them.
- Q42a. NO. Even though both (Y and Z) are different, h, which is the elastic spring force, does not change.
- Q42b. 0.5cm Q42c. The spring is elastic.
- Q43a. The hot water lost heat to the water droplets outside of the container.
- Q43B. Material X is a better heat conductors.
- Q44a. Elastic Potential → Kinetic
- Q44b. Some of the kinetic energy of the ball is converted to heat and sound energy.
- Q44c. The ball has more GPE to convert to KE.

THE END

