

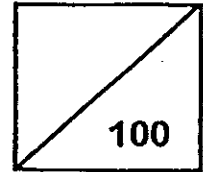

Rosyth School
Second Semestral Examination for 2013
SCIENCE
Primary 4

Name: _____

Total
Marks:



Class: Pr 4 _____ Register No. _____ Duration: 1 h 45 min

Date: 24th October 2013

Parent's Signature: _____

Booklet A

Instructions to Pupils:

1. Do not open the booklets until you are told to do so.
2. Follow all instructions carefully.
3. This paper consists of 2 booklets, Booklet A and Booklet B.
4. For questions 1 to 30 in Booklet A, shade the correct ovals on the Optical Answer Sheet (OAS) provided using a 2B pencil.
5. For questions 31 to 44, give your answers in the spaces given in Booklet B.

* This booklet consists of 17 pages.

3. The diagram below shows a plant. Which part helps to hold the plant upright?

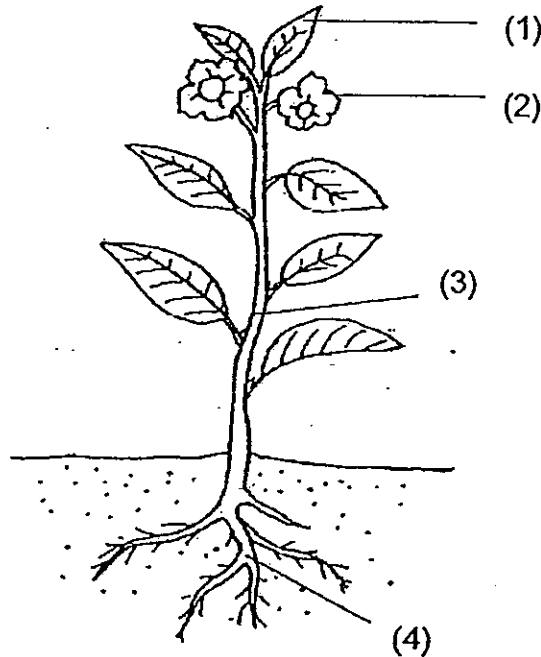

4. Reproduction is one of the characteristics of living things. At which stage of their life cycle do living things reproduce?

- | | |
|----------|-----------|
| (1) Egg | (2) Larva |
| (3) Pupa | (4) Adult |

5. Mr Tan wanted to keep some cookies in a container. He needs a light container that he can see through and does not break easily. Which material should the container be made of?

- | | |
|-----------|-------------|
| (1) Clay | (2) Glass |
| (3) Metal | (4) Plastic |

6. Which one of the following can be attracted by a magnet?

- | | |
|-----------------|------------------|
| (1) Copper ball | (2) Gold ball |
| (3) Iron ball | (4) Plastic ball |

7. Which one of the following is a source of light?

(1) Mirror

(2) Moon

(3) Table

(4) Candle flame

8. In which one of the following arrangements will the two magnets pull each other?

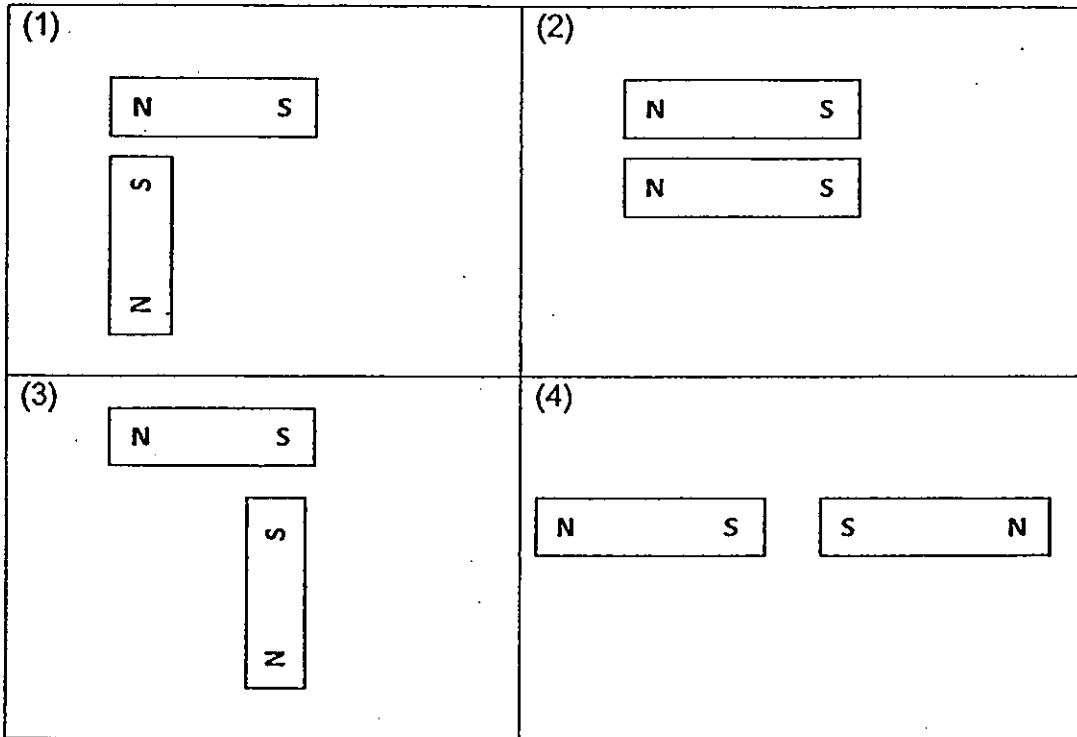

9. Arun shines a torch on the metal container as shown below.

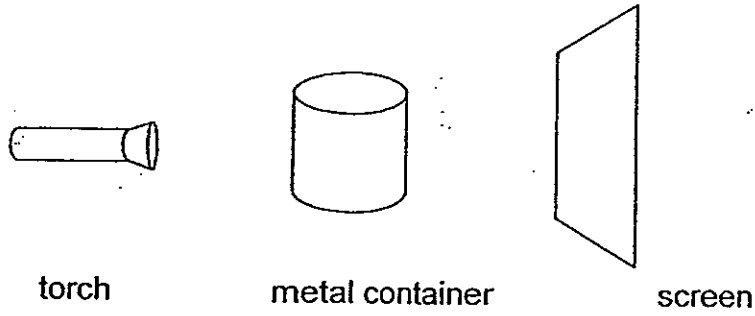

Which one of the following shows the shadow of the metal container on the screen?

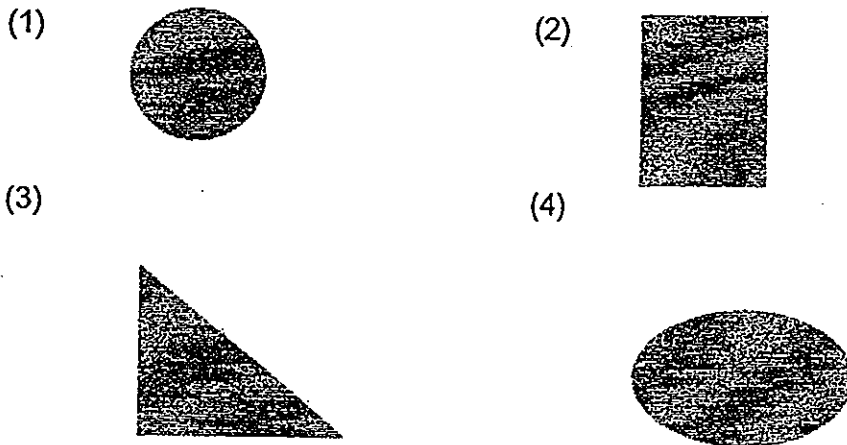

10. Study the picture below.

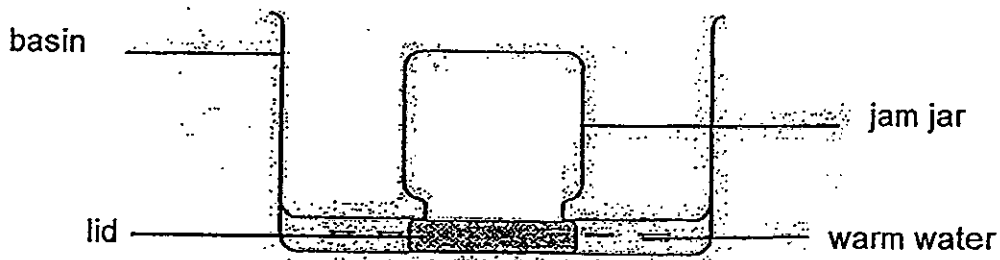

Which one of the following may not take place in the above set-up?

- (1) The warm water lost heat to the lid.
- (2) The lid gained heat and it expanded.
- (3) The jam jar expanded more than the lid.
- (4) The basin gained heat from the warm water.

11. The table below shows the comparisons between the life cycles of Animal, X and Y.

	Animal X	Animal Y
Number of stages	3 stages	4 stages
Method of reproduction	Lays eggs	Lays eggs
Resemblance to adult	Yes	No

Which one of the following correctly identifies Animal X and Y?

	Animal X	Animal Y
(1)	frog ✗	butterfly ✓
(2)	mosquito ✗	frog ✓
(3)	chicken ✓	mosquito ✓
(4)	butterfly ✗	mealworm beetle ✗

12. Sarah observed and recorded the changes that took place as a green bean seed germinated.



Which one of the following statements is incorrect?

- (1) The root grows out before the shoot.
- (2) The root and shoot grow in opposite direction.
- (3) The seedling will get food only when the first leaf appears.
- (4) The seed leaf starts to shrivel and drop as the seed continues to grow.

13. Zheng Wei wanted to find out if the presence of water affects seed germination using two of the set-ups as shown below.

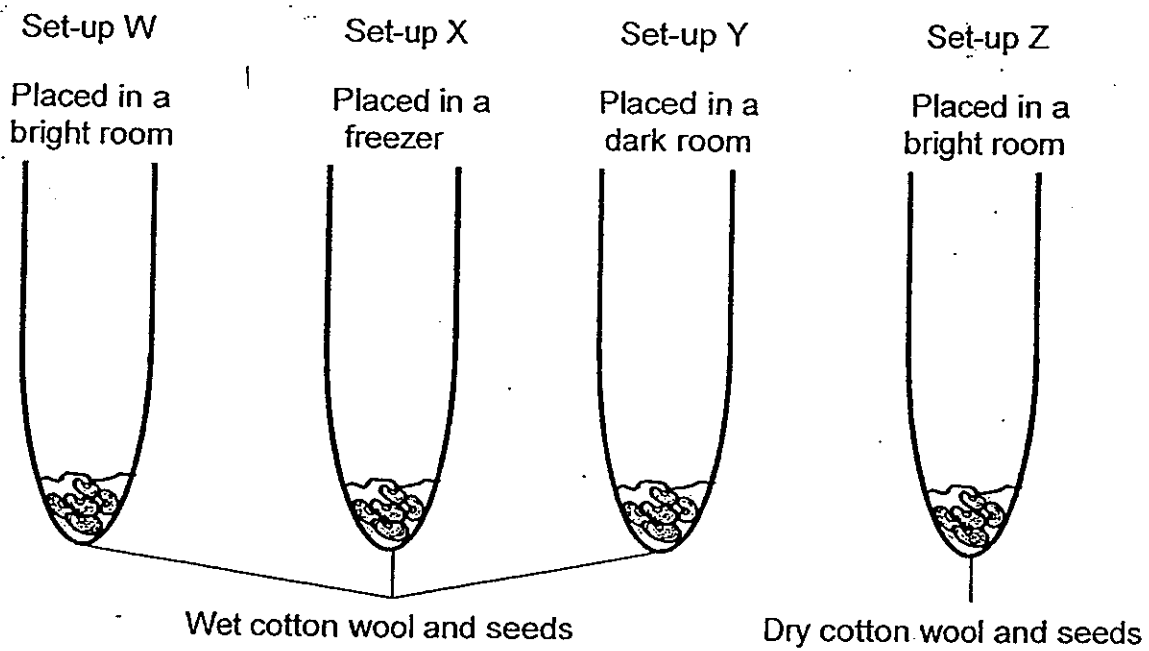

Which two of the following set-ups should he use to ensure a fair test?

- (1) W and X
- (2) W and Z
- (3) X and Y
- (4) Y and Z

14. Which one of the statements below best describes the human body?

- (1) It is made up of one system that carries out a single function.
- (2) It is made up of one system that carries out different functions.
- (3) It is made up of many systems that carry out different functions.
- (4) It is made up of many systems that carry out the same function.

15. Study the flowchart carefully.

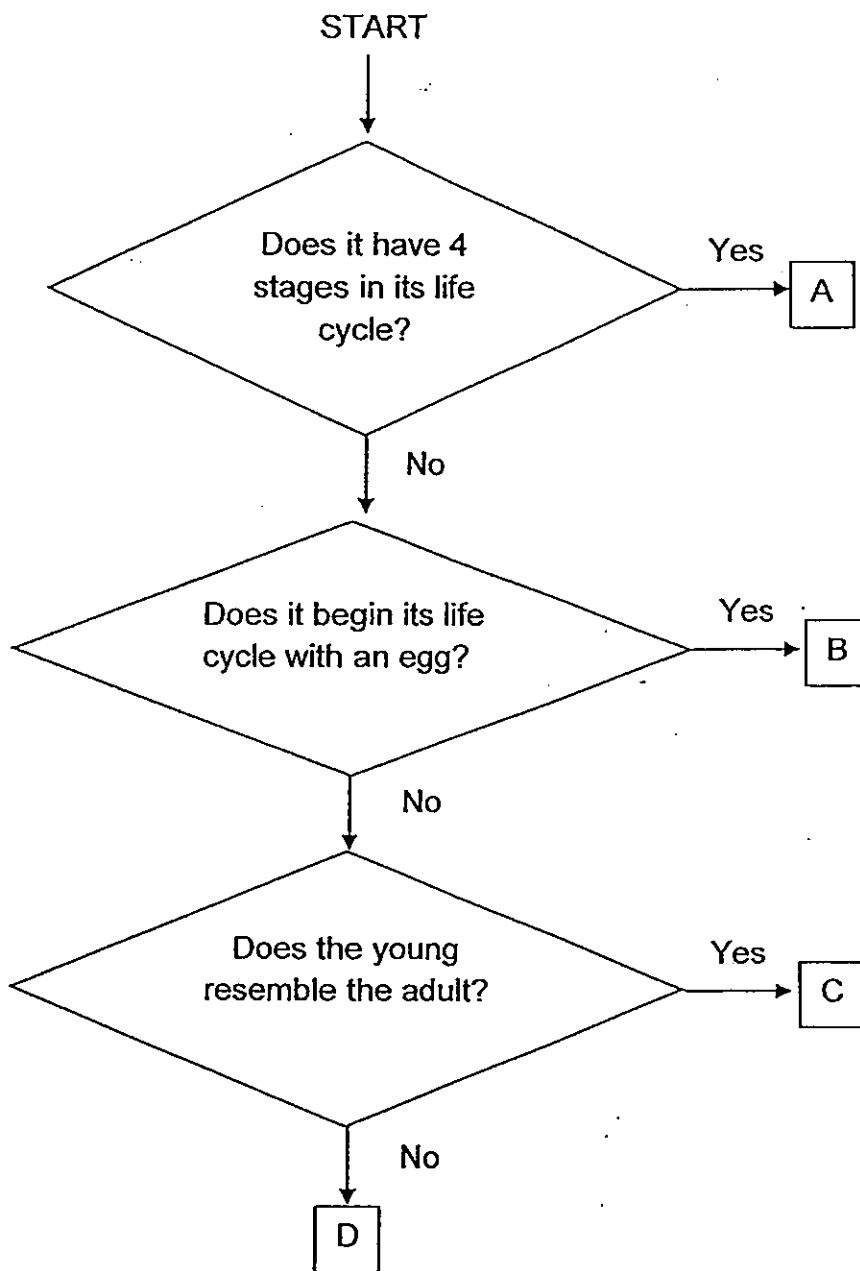

Based on the above flowchart, where will a tomato plant be placed?

- (1) A
- (2) B
- (3) C
- (4) D

16. Siti put a plant into a beaker of water. Two days later, she found that the water level in the beaker has decreased.

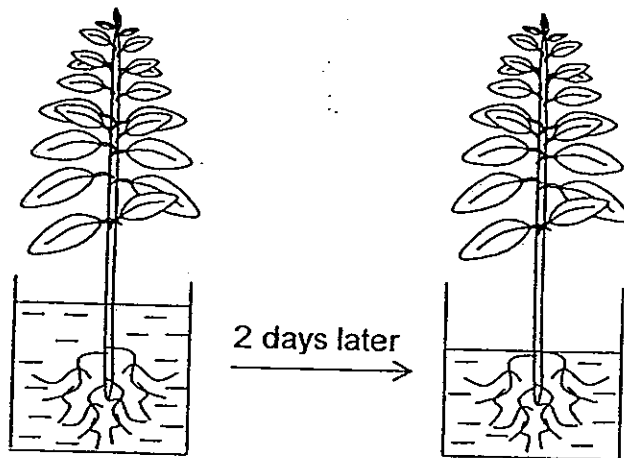

What did the above observation show?

- (1) Plants take in water.
 - (2) Leaves need water to make food.
 - (3) Roots are needed to absorb water.
 - (4) Stems are needed to support the plant.
17. In the diagram below, the arrows (\longrightarrow) and (\dashrightarrow) in the diagram represent the transportation of water and food from one part of a plant to another.

X and Y represent different parts of the plant.

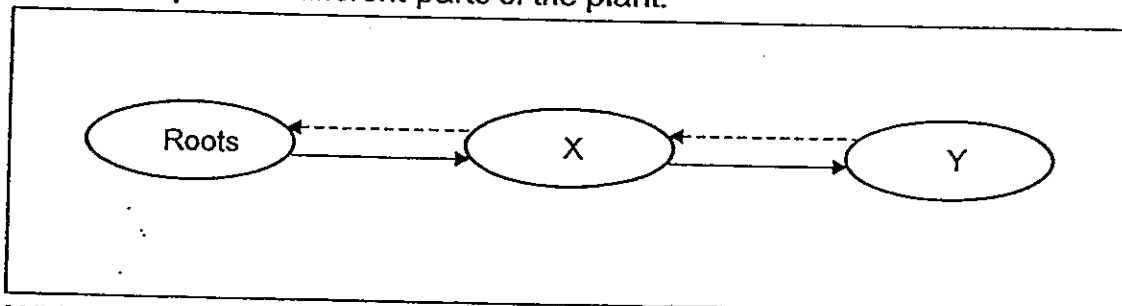

Which one of the following correctly represents the arrows (\longrightarrow) and (\dashrightarrow) and X and Y?

	\longrightarrow	\dashrightarrow	X	Y
(1)	Food	Water	Fruit	Leaf
(2)	Food	Water	Stem	Fruit
(3)	Water	Food	Stem	Leaf
(4)	Water	Food	Leaf	Stem

21. Devi wanted to test if Material X is less flexible than Material Y. Which one of the following set-ups should she use to ensure that it is a fair experiment?

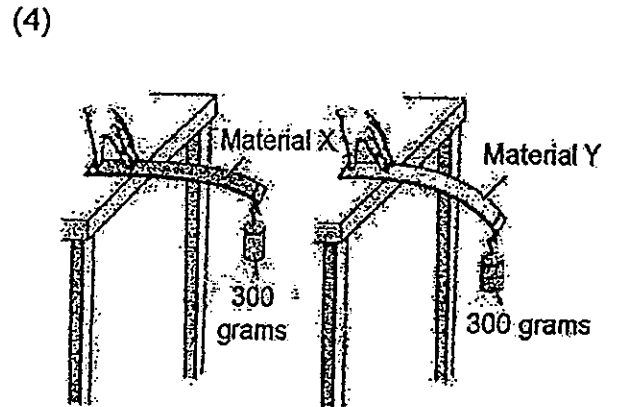
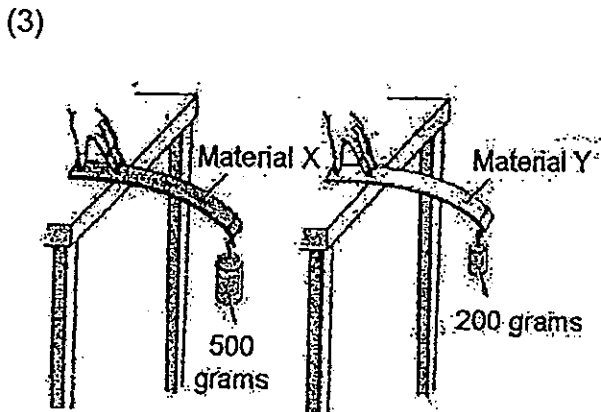
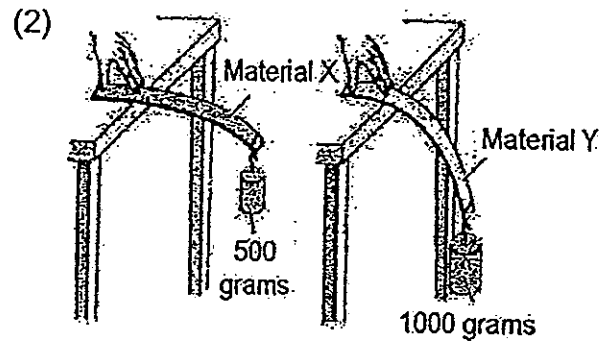
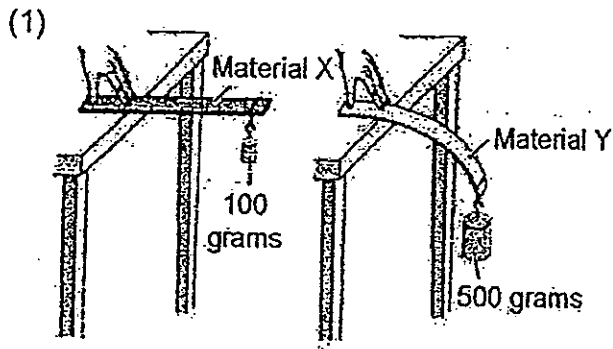

22. David hung four magnets using strings as shown below to find out their strength.

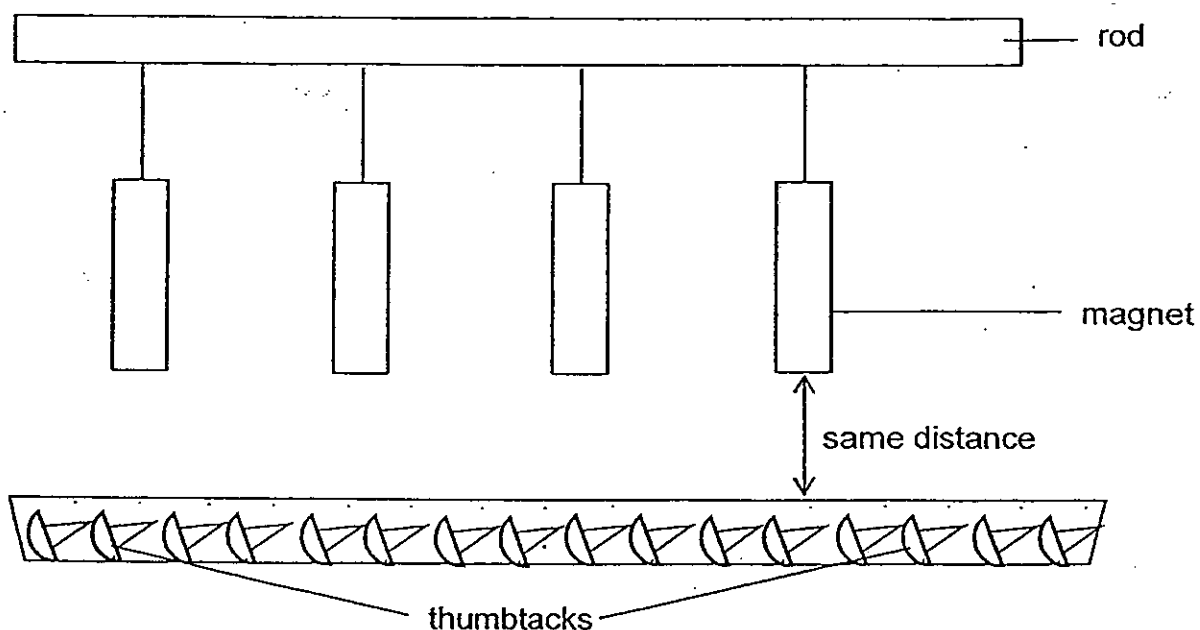

What is the measured variable in the above experiment?

- (1) The strength of the string
- (2) The time taken for thumbtacks to be attracted
- (3) The distance of the magnets from the thumbtacks
- (4) The number of thumbtacks attracted by the magnets

23. The diagrams below show two set-ups involving Object Y.

In Set-up P, Object Y was first placed on the table top. Object X was then placed under the table. When Object Y was pushed across the table top, object X was pulled along with Object Y, moving in the same direction as Object Y.

Set-up Q shows what happened when Object Y was hung freely on a string and placed close to a freely suspended magnet.

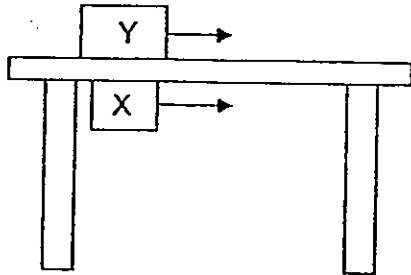

Set-up P

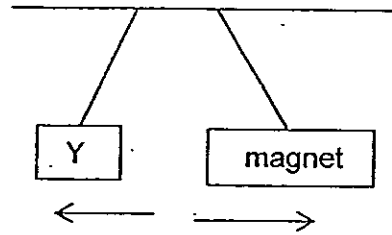

Set-up Q

Based on the set-ups above, which of the following statements are definitely true?

A: Object X is a magnet.

B: Object Y is a magnet.

C: Object X and Y are made of magnetic materials.

(1) A and B only

(2) A and C only

(3) B and C only

(4) A, B, and C

24. Sally had a magnet. She labelled 5 parts of the magnet as shown below.

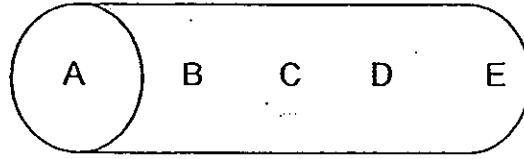

She put the magnet into a box of nails. She recorded the number of nails attracted to the 5 parts of the magnet. She recorded her results in a table below.

Parts of a magnet	A	B	C	D	E
Number of nails attracted to the part	?	4	?	4	10

Which of the following correctly represents A and C in the table above?

	A	C
(1)	4	0
(2)	12	1
(3)	1	10
(4)	10	6

25. Samuel used the graph below to conclude that silver is the best conductor of heat while mild steel is the poorest.

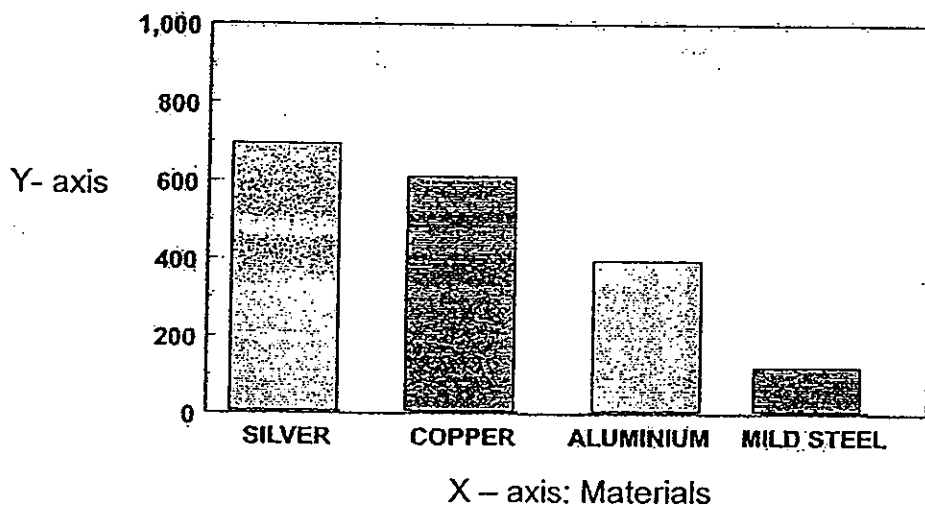

Based on his conclusion, which one of the following should be the variable for Y- axis in the graph above?

- (1) The mass of the materials
- (2) The volume of the materials
- (3) The temperature of the materials
- (4) The transparency of the materials

26. The thumbtacks, A, B, C and D, were attached to the steel rod using candle wax.

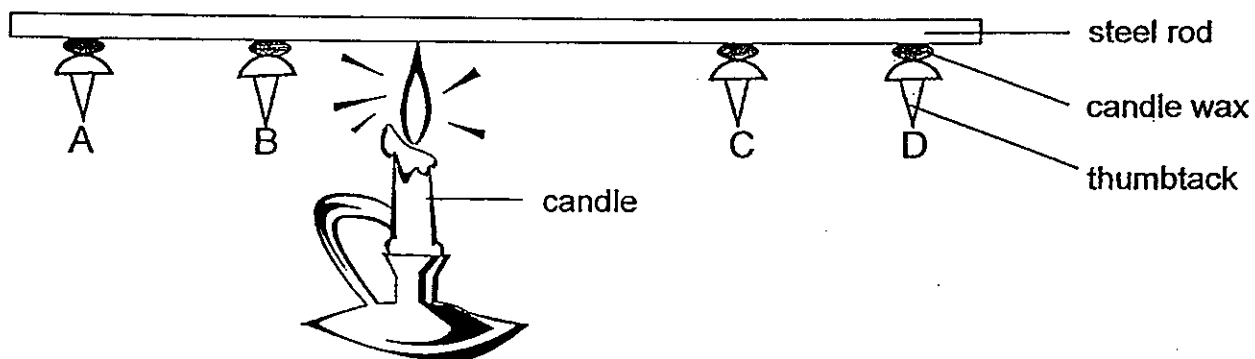

A candle flame was used to heat the rod as shown above. Which thumbtack will drop first?

- | | |
|-------|-------|
| (1) A | (2) B |
| (3) C | (4) D |

29. The experiment shown below was carried out in a dark room. Sheets D, E, F, G, and H were arranged in a straight line.

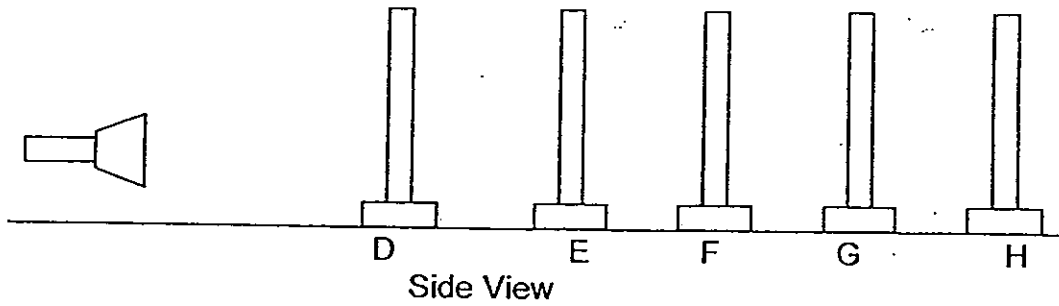

A diamond – shaped hole was found on sheet D as shown below.

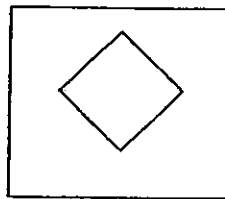

The properties of the materials are shown below.

Allows light to pass through	Does not allow light to pass through
E	D
H	F
	G

When the torch was switched on, on which sheet would a bright diamond shape be seen?

- (1) E
- (3) G

- (2) F
- (4) H

30. A torch was used to shine at an opaque cup from four different directions as shown below.

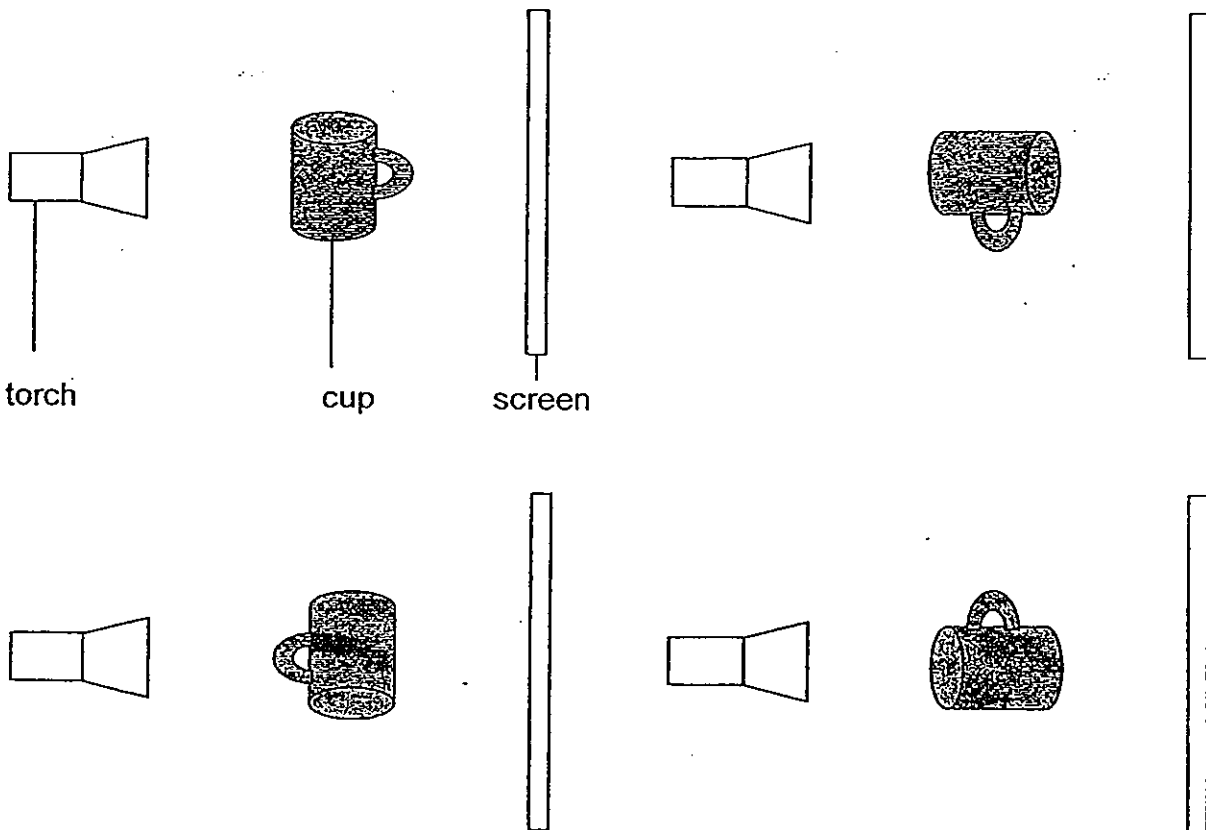

How many different types of shadows of the cup can be cast on the screen?

- (1) 0
- (3) 3

- (2) 1
- (4) 4

End of Part I



Rosyth School
Second Semestral Examination for 2013
SCIENCE
Primary 4

Name: _____

Total
Marks:

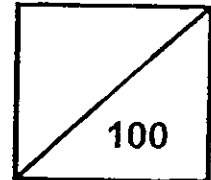

Class: Pr 4 _____ Register No. _____ Duration: 1 h 45 min

Date: 24th October 2013 Parent's Signature: _____

Booklet B

Instructions to Pupils:

1. For questions 31 to 44, give your answers in the spaces given in this Booklet B.

	Maximum	Marks Obtained
Booklet A	60 marks	
Booklet B	40 marks	
Total	100 marks	

* This booklet consists of 14 pages.

This paper is not to be reproduced in part or whole without the permission of the Principal.

Part II (40 marks)

For questions 31 to 44, write your answers in this booklet.

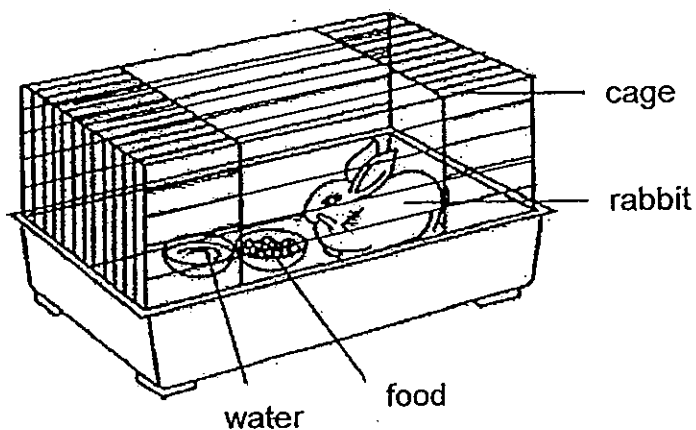

31. Bala has a pet rabbit as shown below.



(a) After a few days, will the amount of food in the bowl increase, decrease or remain the same? (1m)

(b) State the needs of the rabbit to remain alive. (1m)

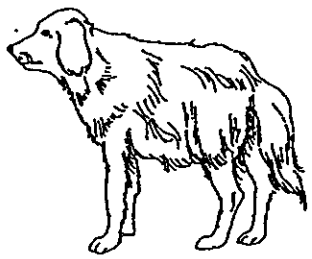
Bala grouped some animals into 2 groups, A and B, based on their physical characteristics.

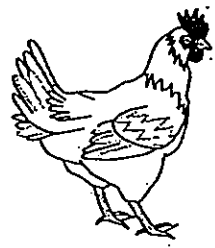
Group A		Group B	
			
Cat	Dog	Duck	Chicken

He wanted to place the rabbit either in group A or B based on their physical characteristics.

(c) Which group should the rabbit be placed in? Explain why. (1m)

32. Refer to the diagram below.

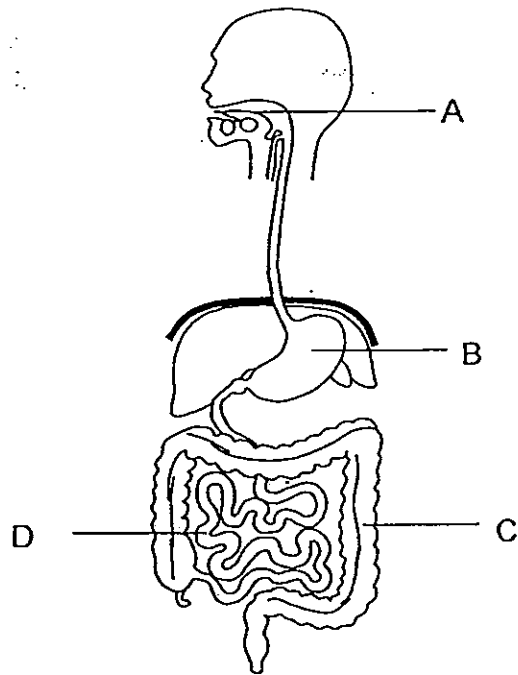

(a) Which part (A, B, C or D) does digestion first takes place? (1m)

(b) Which part (A, B, C or D) is digested food absorbed into the bloodstream? (1m)

33. Mei Ling set up an experiment using two different materials. She placed a 9kg weight on each material as shown below.

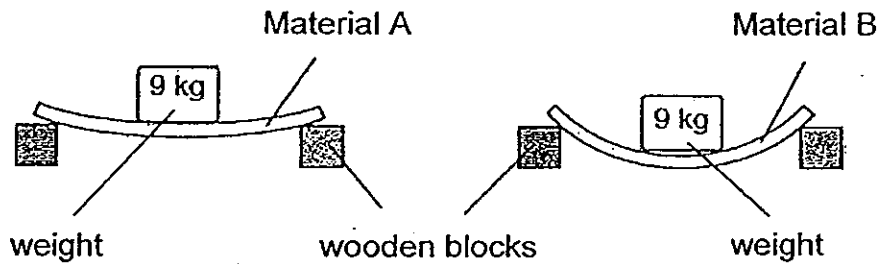

Choose the correct word in the box to fill in the blank in part (a) below.

harder	stronger	more flexible
--------	----------	---------------

(a) Material B is _____ than Material A. (1m)

(b) Based on the experiment above, state the following: (2m)

(i) Changed variable: _____

(ii) Variable kept the same:

34. Ahmad placed an iron rod near a strong magnet.

(a) What do you think would happen? (1m)

Next, Ahmad placed a copper rod near the strong magnet.

(b) What do you think would happen? Explain why. (2m)

35. Gopal compared the mass of three fruits using weighing balances.

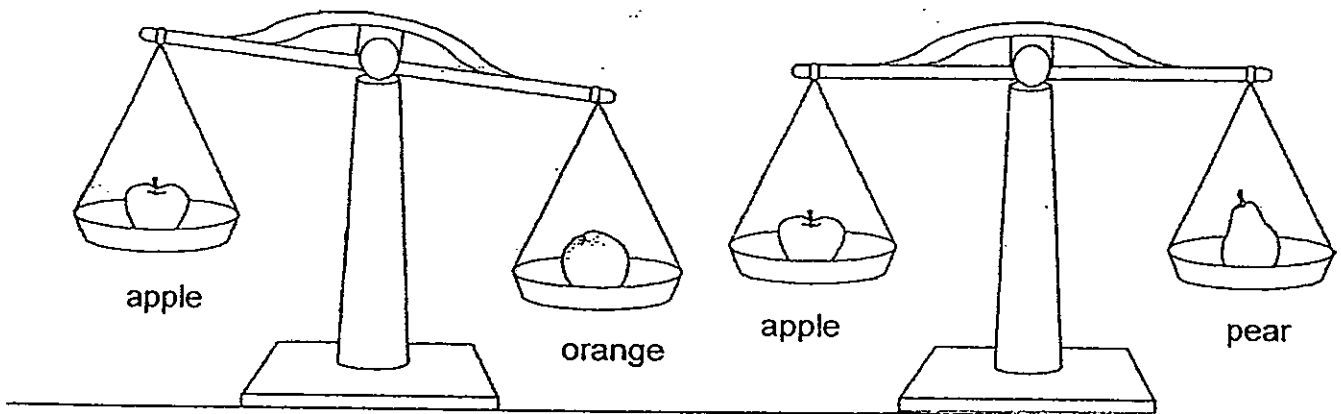

Based on the observations above, write 'True,' 'False' or 'Not possible to tell' for the following statements. (2m)

Statements	'True,' 'False' or 'Not possible to tell'
(i) The orange is lighter than the apple.	
(ii) The apple has the same mass as the pear.	
(iii) The orange is heavier than the pear.	
(iv) The apple has the same volume as the orange.	

36. Refer to the instrument below.

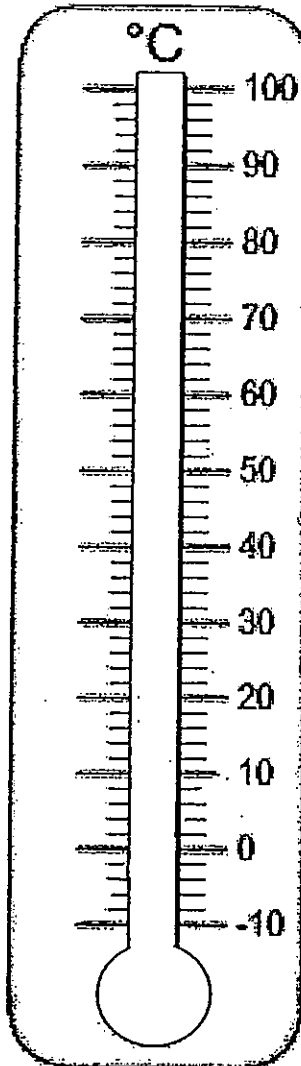

(a) Name the instrument above.

(1m)

(b) Shade the instrument to show that the temperature is 40 °C.

(1m)

37. The diagram below shows a tadpole and a frog.



tadpole

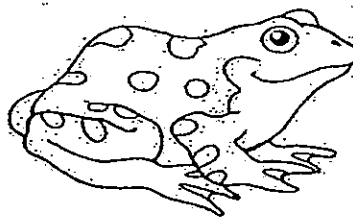

frog

(a) State a difference between the tadpole and the frog with regard to their movement. (1m)

(b) The frog has a similar life cycle as the dragonfly as shown below.



State 2 similarities between their life cycles. (2m)

(i) _____

(ii) _____

38. Jason placed a plant in a beaker of water and measured the amount of water left in the beaker at the end of each day. The graph below shows the result of his experiment.

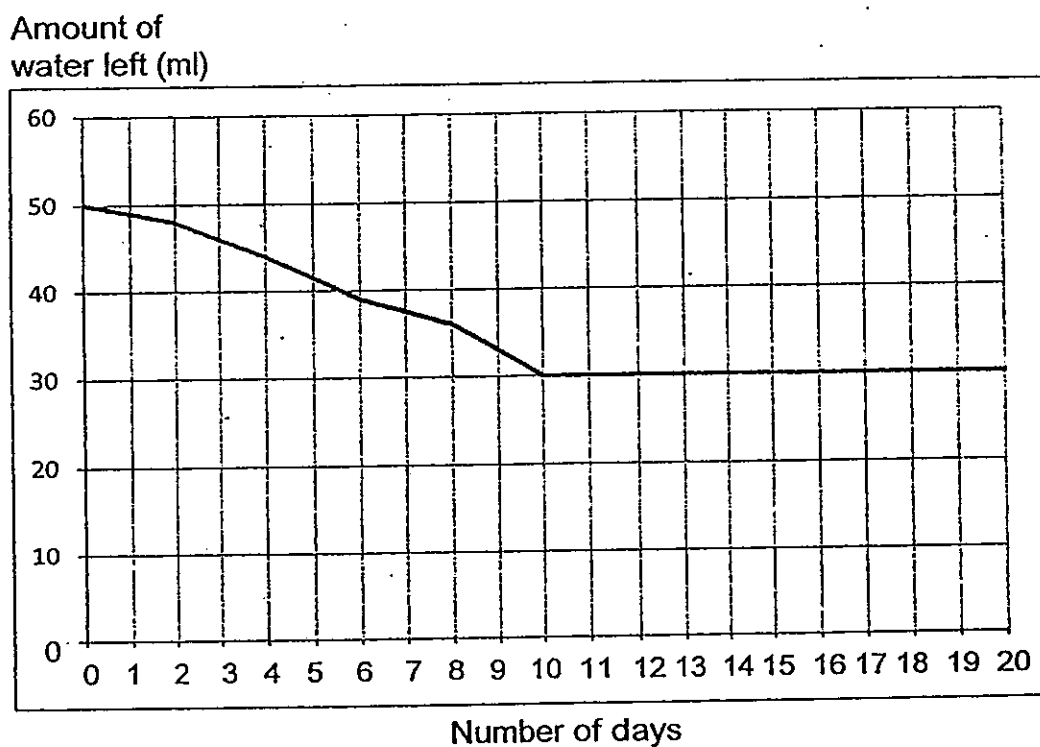

- (a) Based on the graph above, describe the changes in the amount of water left from Day 1 to Day 20. (2m)

- (b) After measuring the amount of water left on Day 10, he covered the roots completely using a plastic bag. Give a reason for the results obtained from Day 11 to Day 20. (1m)

39. Mary wanted to pour some milk into a bottle as shown below but she could not do it. No milk entered the bottle.

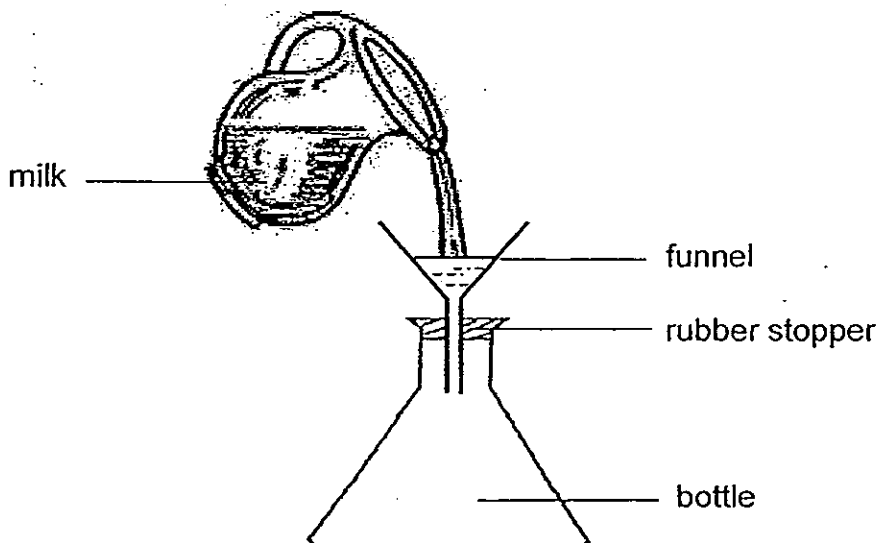

(a) Explain why the milk did not enter the bottle. (2m)

(b) What should Mary do to the set-up above to allow the milk to enter the bottle? (1m)

(c) Study the classification chart below.

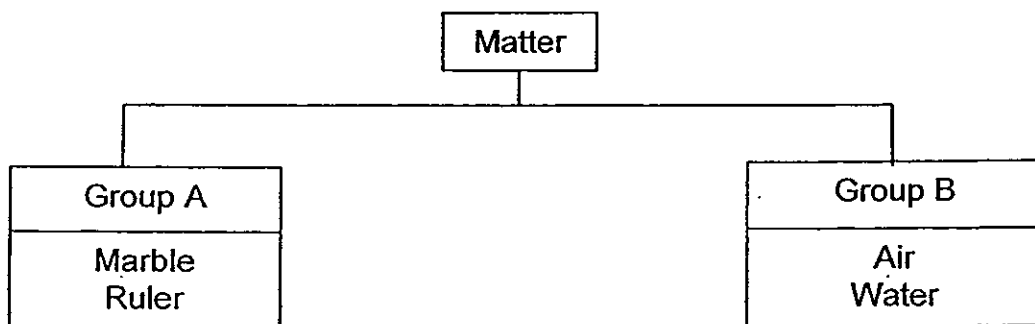

In which group should milk be placed? State a reason for your choice. (1m)

40. The set-up below consists of three rings A, B and C. Two of them are ring magnets and one is a plastic ring. Ring B "floats" above Ring C.

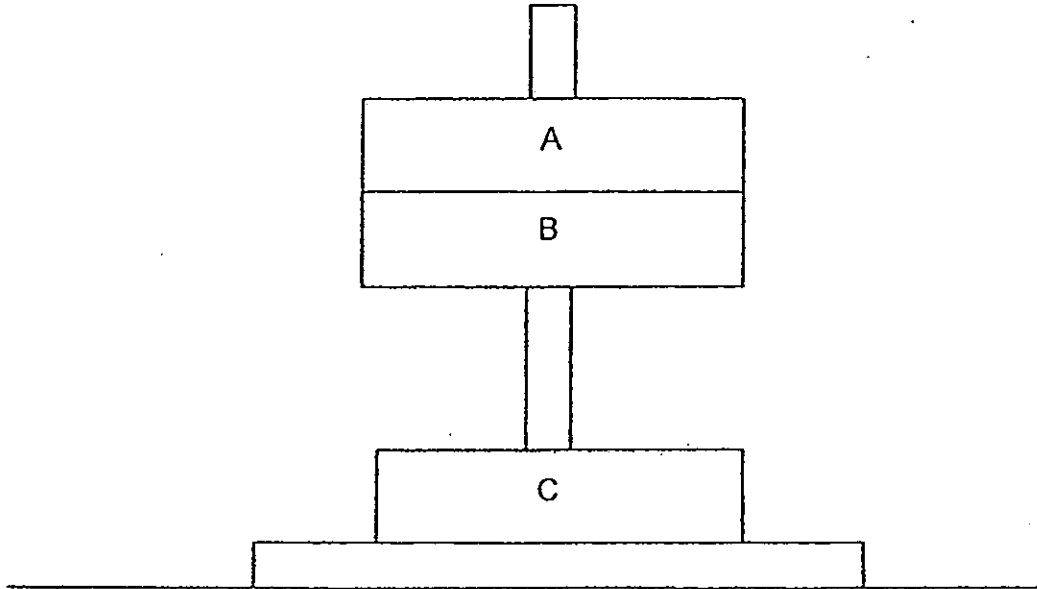

- (a) Which rings do you think are magnets? Support your choice. (1m)

- (b) What would you do to show that Ring A is the plastic ring using the set-up above? (1m)

- (c) What observation would he see in (b) to support that Ring A is the plastic ring? (1m)

41. Ariel placed 3 magnets as shown below in Diagram A.

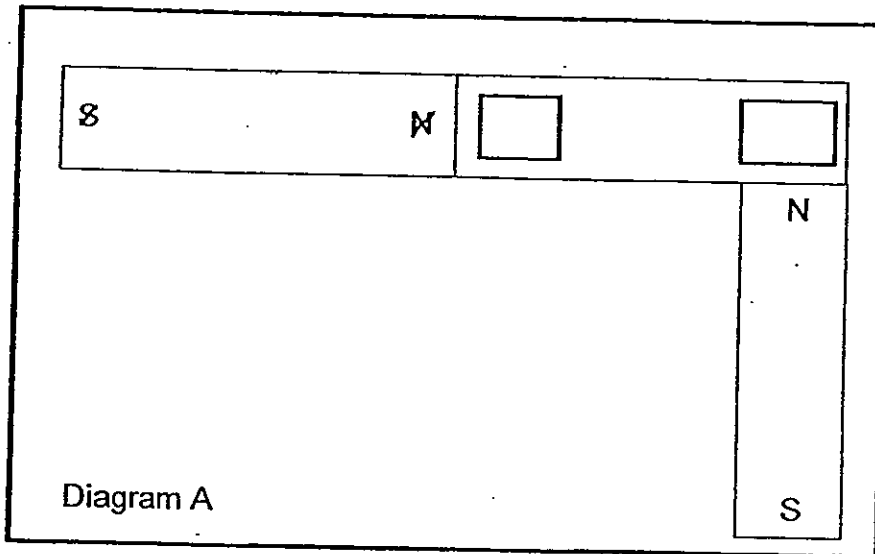

- (a) Write the missing poles of the magnet in Diagram A. (1m)
- (b) State the property of magnet as shown in Diagram A. (1m)

- (c) Rearrange the 3 magnets in such a way that the magnets are repelling. Draw the new arrangement in Diagram B below. Label the poles of the magnets. (1m)

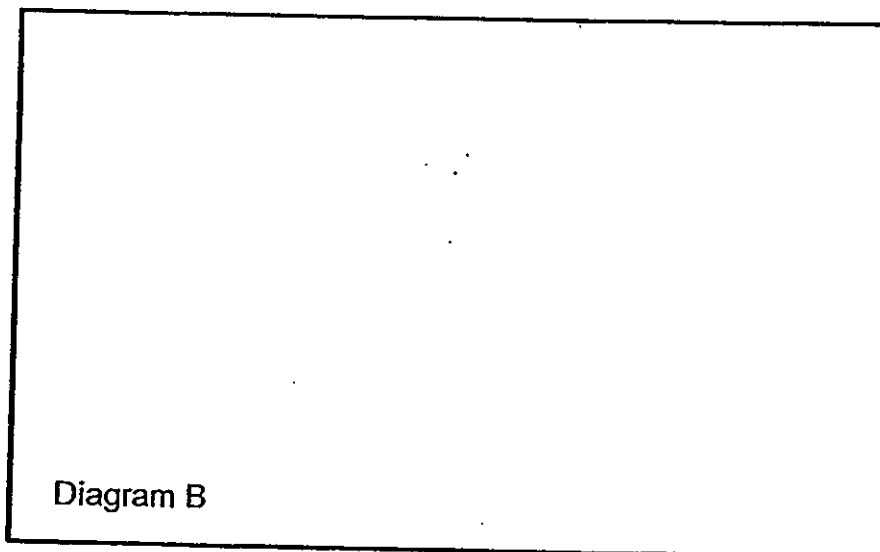

42. Kelvin classified the objects as shown below in the table.

Transparent	Translucent	Opaque
Object A	Object B	Object C

(a) Explain why he has classified Object B as translucent. (1m)

(b) Which of the above object will form the darkest shadow? Support your choice. (1m)

Kelvin used the container to keep his cookies as shown below.

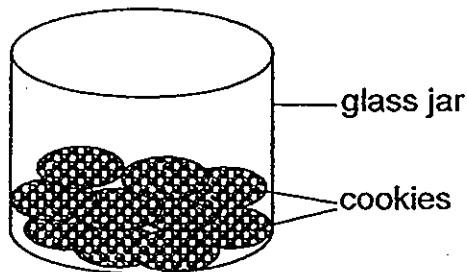

(c) In which of the above group, should he place the container? Explain why. (1m)

43. Study the diagram below.

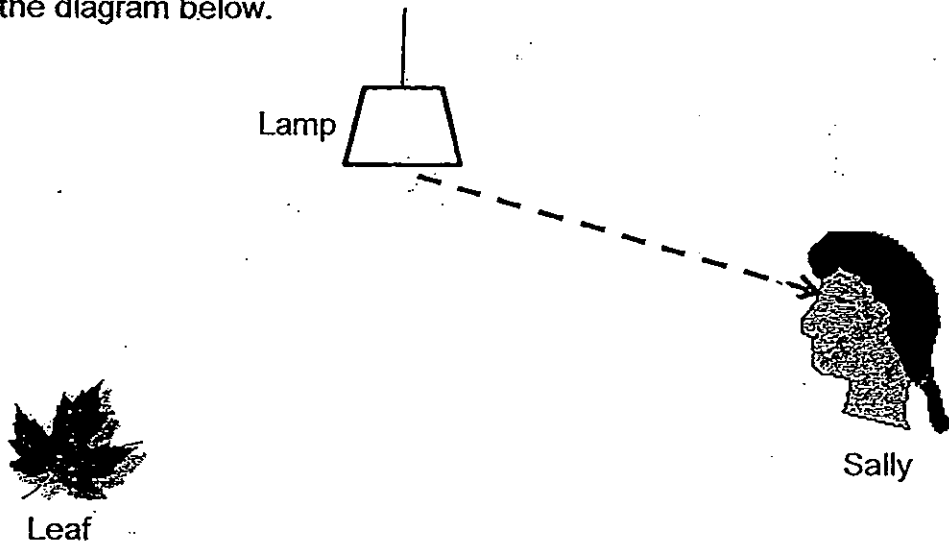

The diagram shows the path of light travelling from the lamp to Sally's eyes so that she can see the light.

- (a) Draw the path of light in the above diagram to show how light travels to enable Sally to see the leaf. (1m)
- (b) Explain why there is a difference between the pathways of how light travels from the lamp and the leaf to enable Sally to see them. (1m)

44. Kok Meng took two metal spoons from a room and placed them in two cups of hot water and cold water respectively.

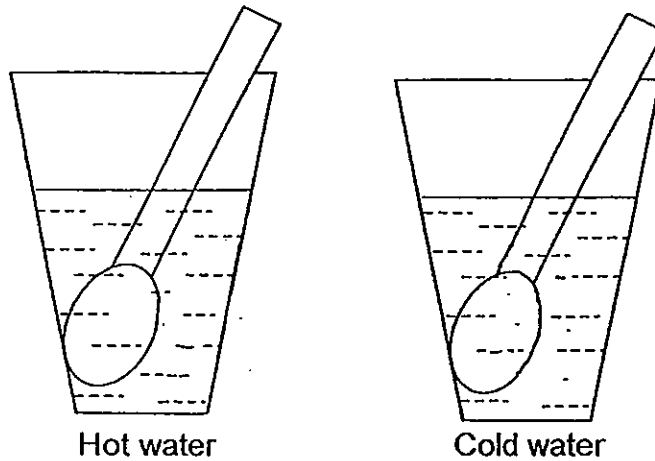

(a) Draw arrows to show how heat travels in the two cups. (2m)

In another experiment, Kok Meng took the ball and ring apparatus. The ball was able to pass through the ring.

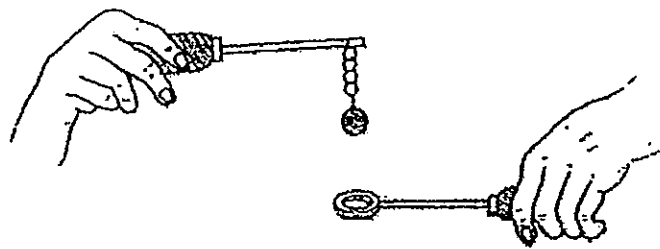

He heated the iron ball as shown below for some time.

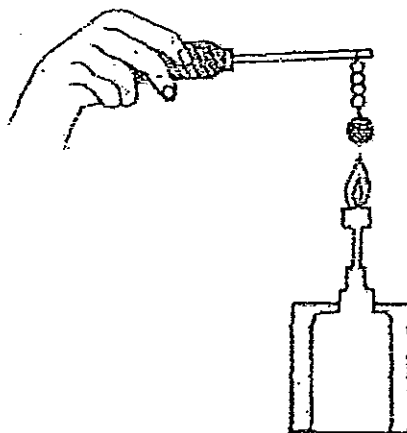

Question 44 is continued on page 14

He tried to pass the ball through the ring again.

(b) What do you think would he observe?

(1m)

(c) Describe what has happened for the above observation as mentioned in (b). (1m)

End of Paper



ANSWER SHEET

EXAM PAPER 2013
SCHOOL : ROSYTH

SUBJECT : PRIMARY 4 SCIENCE

TERM : SA2

Q1	Q2	Q3	Q4	Q5	Q6	Q7	Q8	Q9	Q10	Q11	Q12	Q13	Q14	Q15	Q16	Q17
1	3	3	4	4	3	4	1	2	3	3	3	2	3	3	1	3

Q18	Q19	Q20	Q21	Q22	Q23	Q24	Q25	Q26	Q27	Q28	Q29	Q30
3	2	4	4	4	3	2	3	2	1	3	2	3

Q31a) Decrease

Q31b) The rabbit needs air, food, water to survive.

Q31c) A. The rabbit walks on 4 legs while the two animals in group A also walk on 4 legs.

Q32a) A

Q32b) D

Q33a) more flexible

Q33bi) type of material

Q33bii) weight on the block

Q34a) The iron rod would be attracted by the strong magnet.

Q34b) The copper rod would not be attracted by the strong magnet. Copper is not a magnetic material.

Q35i) False

Q35ii) True

Q35iii) True

Q35iv) Not possible to tell

Q36a) thermometer

Q36b)

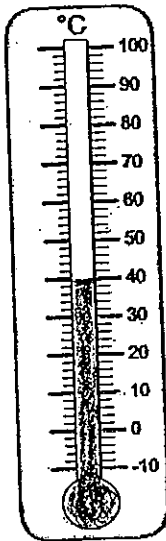

Q37a) The tadpole uses its tail to push itself around while the frog uses its hind legs to move around.

Q37bi) Both life cycles start with the egg stage.

Q37bii) Both life cycles have three stages.

Q38a) From day 1 to day 10, the amount of water decreases, but from day 10 onwards to day 20, the amount of water remains the same.

Q38b) The plastic bag does not allow water to enter, thus the plant cannot absorb the water.

Q39a) The rubber stopper does not allow the air in the bottle to escape, and since the air is occupying the space in the bottle, the milk cannot enter.

Q39b) Remove the rubber stopper.

Q39c) B. The items in group B takes the shape of the container but the items in group A do not take the shape of the container.

Q40a) B and C. Only magnets can repel each other.

Q40b) Turn ring A the other way.

Q40c) Ring A would not repel ring B.

Q41a)

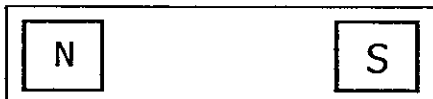

Q41b) unlike poles attract

Q41c)

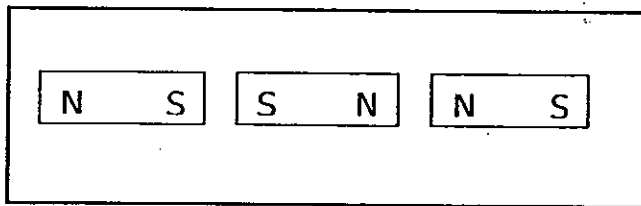

Q42a) Object B only allow some light to pass through.

Q42b) Object C. C blocks all of the light from passing through, thus a shadow is formed.

Q42c) A. Glass allows all of the light to pass through.

Q43a)

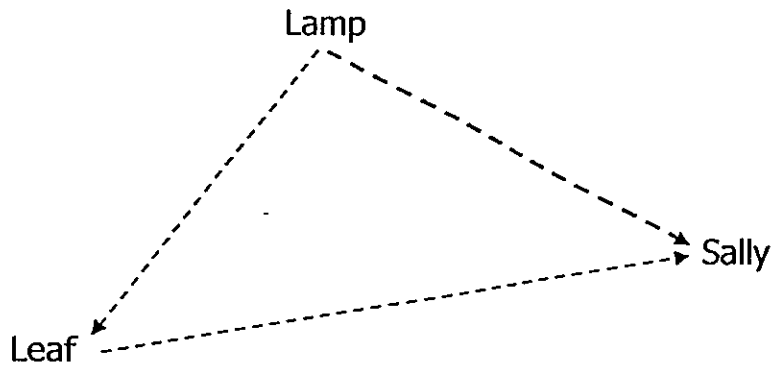

Q43b) The lamp is a light source of light while the leaf is not a source of light.

Q44a)

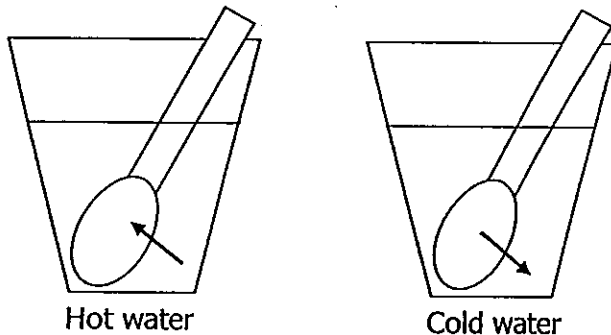

Q44b) The ball cannot pass through the ring.

Q44c) The ball is made of metal. Metal expands when heated. As the ball is bigger than the ring, it cannot pass through.

