

24

Index No: 

--	--	--	--	--	--



Anglo-Chinese School (Junior)  
Anglo-Chinese School (Primary)

**PRELIMINARY EXAMINATION 2016  
SCIENCE  
BOOKLET A  
PRIMARY SIX**

Name: \_\_\_\_\_ ( )

Class: Primary 6 \_\_

Date: 25 August 2016

Duration of paper: 1 h 45 min

**INSTRUCTIONS TO CANDIDATES**

1. Write your name, register number and class.
2. Do not turn over this page until you are told to do so.
3. Follow all instructions carefully.
4. Answer all questions.
5. Shade your answer on the Optical Answer Sheet (OAS) provided.
6. This question paper consists of 20 printed pages including this cover page.

**PART I**

For each question from 1 to 30, four options are given. One of them is the correct answer. Make your choice (1, 2, 3 or 4) and shade your answer on the Optical Answer Sheet.

(60 marks)

- 1 The flowchart below shows the human digestive system. P and Q represent substances found in the system while R and S represent substances leaving the organs in the system.

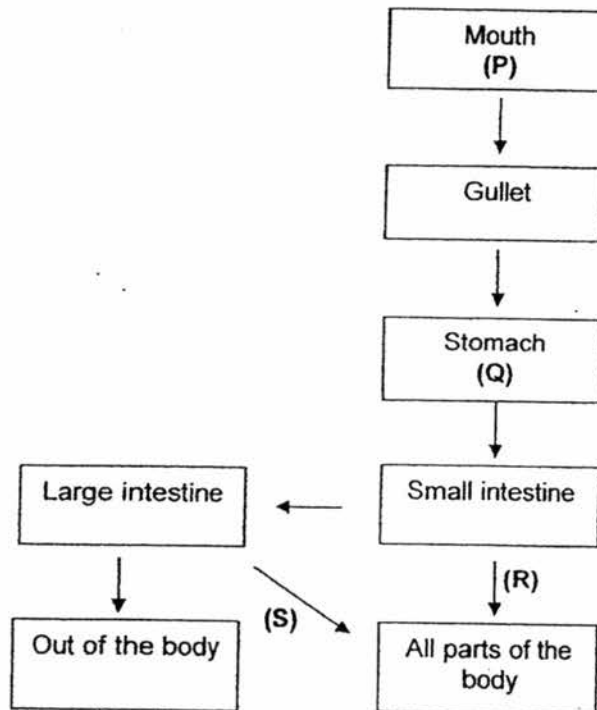

Which one of the following correctly identify P, Q, R and S?

	P	Q	R	S
(1)	digestive juice	saliva	water	digested food
(2)	saliva	digested food	digestive juice	water
(3)	digestive juice	water	saliva	digested food
(4)	saliva	digestive juice	digested food	water

(Go on to the next page)

- 2 Jonathan wanted to set up an experiment to find out if carbon dioxide is necessary for plants to make food as shown in the diagram below.

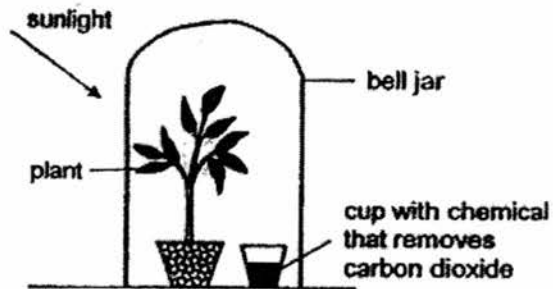

Which one of the following is a suitable control for his experiment?

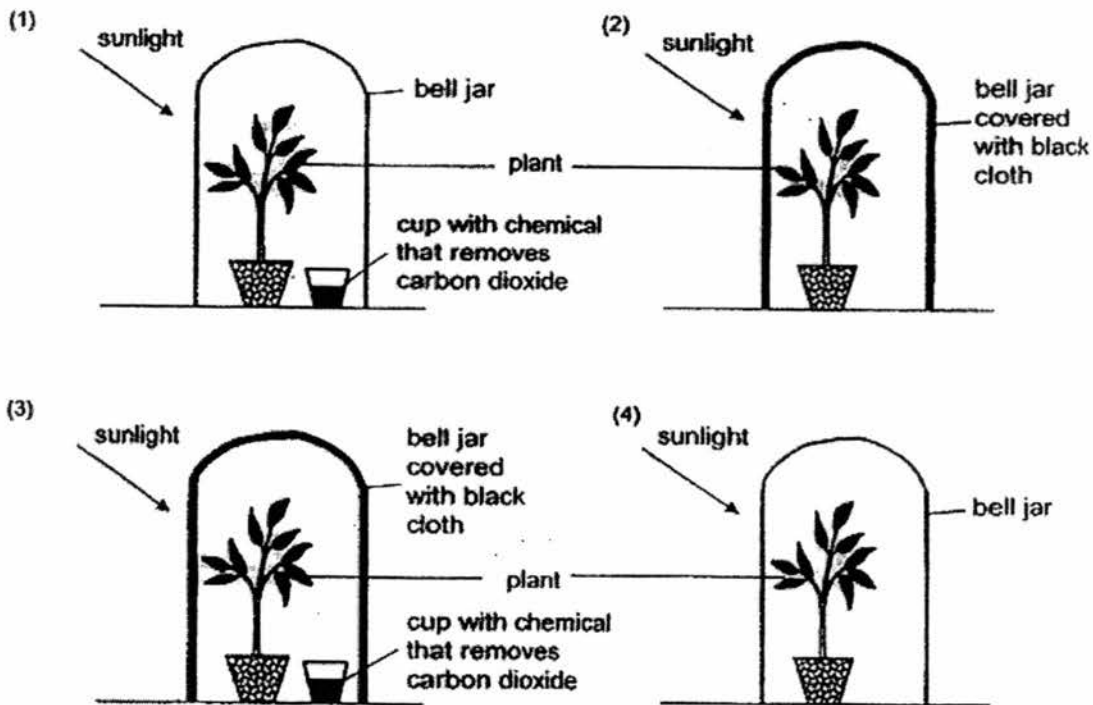

(Go on to the next page)

- 3 The diagrams below show part of the transport system of a plant and a human body.



Plant



Human body

Which of the following statements are true of the systems?

- A Nutrients are transported within both systems.
- B Food made by the leaves is transported to all parts of the plant.
- C Blood is transported from the heart to the rest of the body and back to the heart again.
- D Water is absorbed by the roots and transported to the rest of the plant and back to the roots again.

- (1) A and C only
- (2) B and D only
- (3) A, B and C only
- (4) A, B and D only

- 4 The diagram below shows three cells.

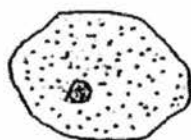

Cell A



Cell B

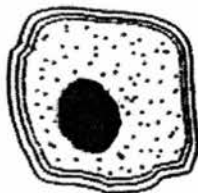

Cell C

Which parts are found in all three cells?

- (1) Cell wall and nucleus
- (2) Cell wall and cytoplasm
- (3) Cytoplasm and cell membrane
- (4) Cell membrane and chloroplast

(Go on to the next page)

- 5 Which one of the following graphs best represents the correct volume of oxygen, carbon dioxide and nitrogen found in inhaled air and exhaled air?

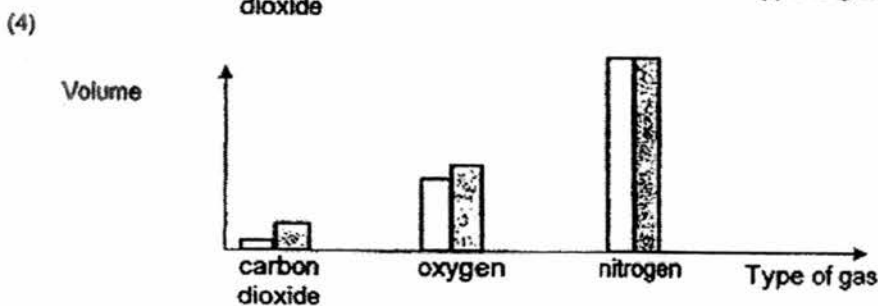
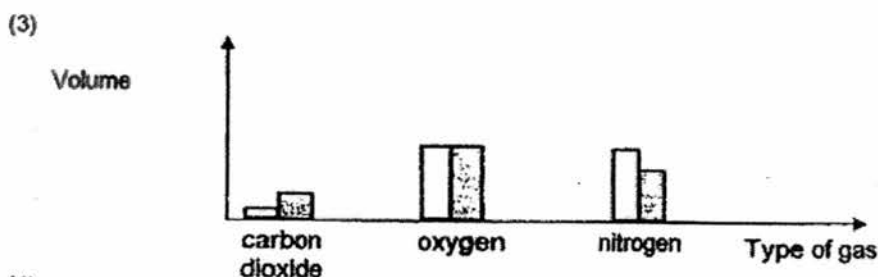
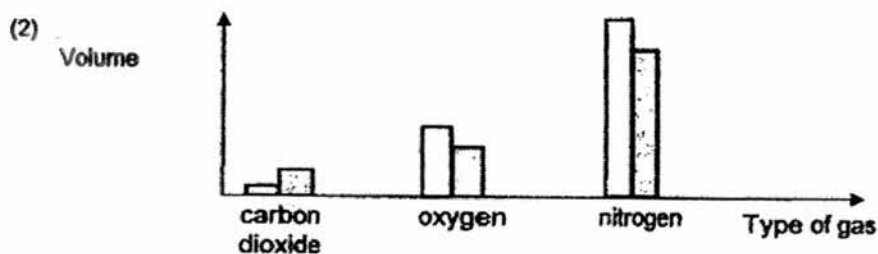
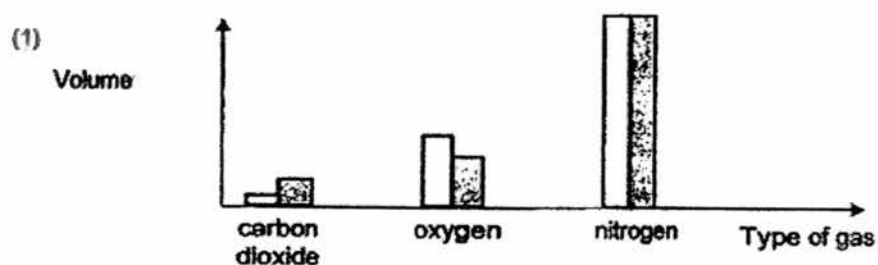
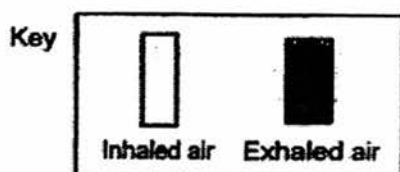

(Go on to the next page)

6 Study the circuit shown below.

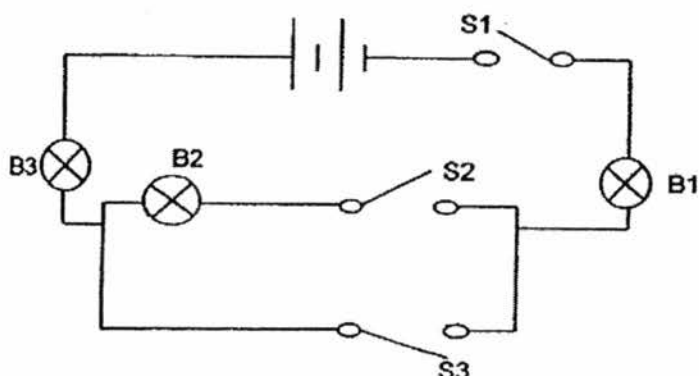

Which one of the following statements about the circuit above is correct?

- (1) When S2 is closed, at least 1 bulb will light up.
- (2) When S1 and S2 are closed, 2 bulbs will light up.
- (3) If B3 fuses, B1 and B2 will not light up when all the switches are closed.
- (4) If B2 fuses, B1 will light up while B3 will not light up when all the switches are closed.

7 The diagram below shows three circuit diagrams. All bulbs, batteries and wires are similar and are in good working condition.

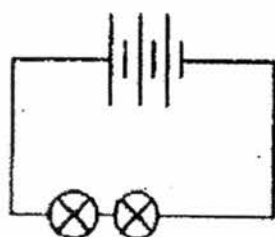

Circuit X

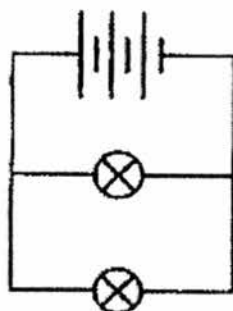

Circuit Y

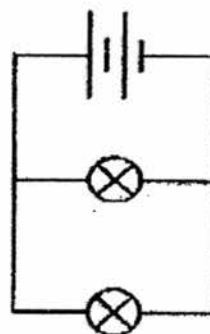

Circuit Z

Arrange the circuits from the brightest bulbs to the dimmest bulbs.

	Brightest bulbs	→	dimmest bulbs
(1)	X		Z
(2)	X		Y
(3)	Y		X
(4)	Y		Z

(Go on to the next page)

- 8 Study the flowchart below.

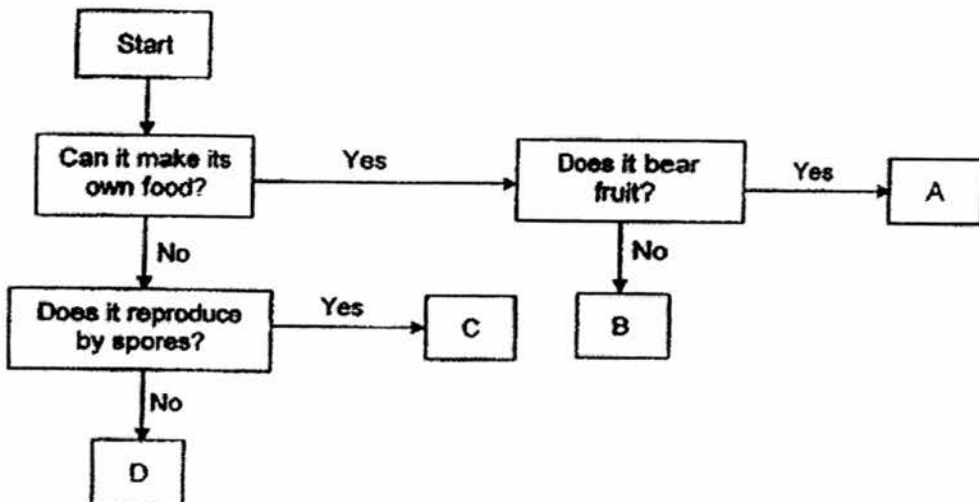

Which one of the following most likely represent, A, B, C and D?

	A	B	C	D
(1)	Fern	Animal	Flowering plant	Bacteria
(2)	Flowering plant	Fern	Fungus	Animal
(3)	Animal	Fungus	Bacteria	Flowering plant
(4)	Flowering plant	Bacteria	Fungus	Animal

- 9 Study the transfer of energy below.

Sun → X → Y → Z

What does the transfer of energy show?

- A X is the food producer.  
 B Y feeds on X to obtain energy.  
 C Food that Y and Z eat comes directly from the Sun.
- (1) A and B only  
 (2) A and C only  
 (3) B and C only  
 (4) A, B and C

(Go on to the next page)

- 10 Phil set up the experiment as shown below. He placed a piece of wood at four different positions, and measured the height of each shadow formed on the screen.

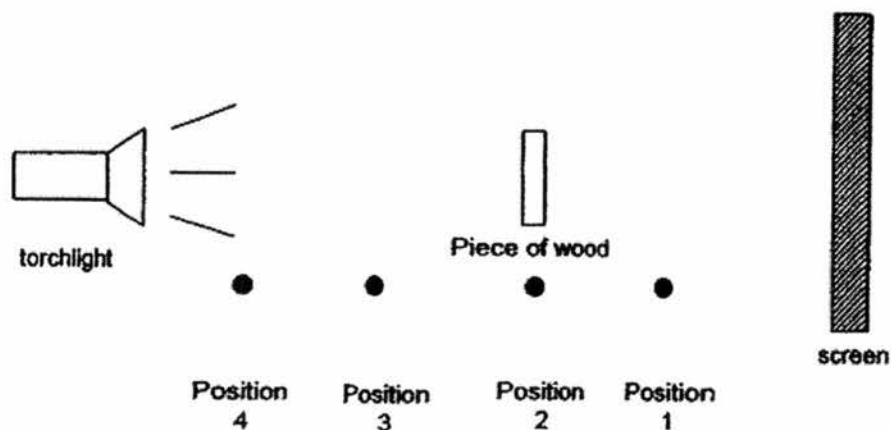

Which graph shows the correct relationship between the position of the piece of wood and the height of the shadow formed?

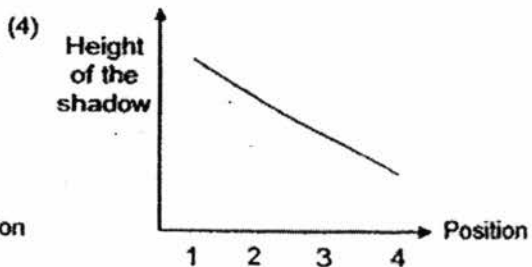
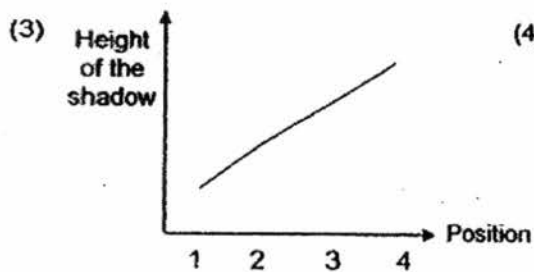
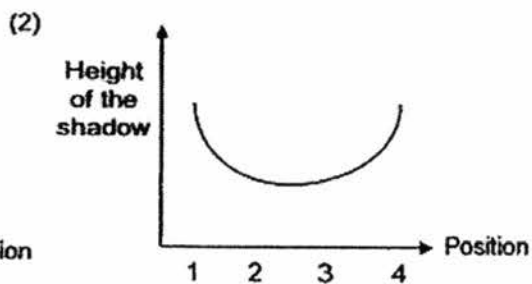
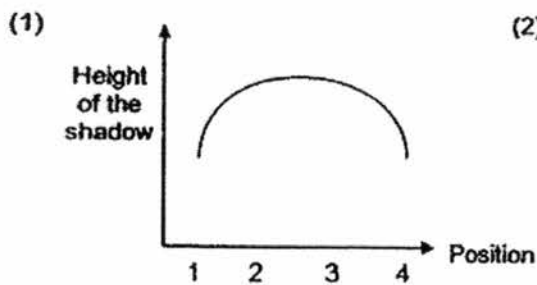

(Go on to the next page)



- 11 An experiment was set up with four identical rods made of different materials, W, X, Y and Z, at the same temperature of  $30^{\circ}\text{C}$ . The rods were placed in a container of ice cubes as shown below.

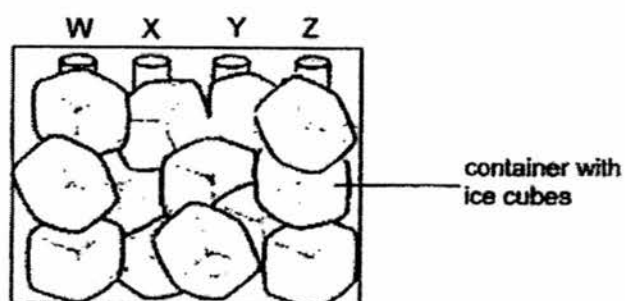

After ten minutes, the rods were taken out and their temperatures were recorded in the table below.

Materials	Temperature ( $^{\circ}\text{C}$ )
W	4
X	20
Y	10
Z	28

Based on the result above, which material is most suitable for making the part labelled 'H'?

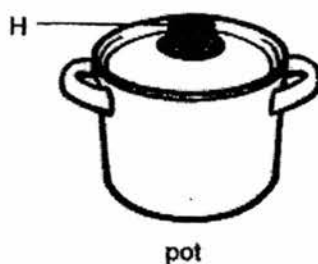

- (1) W
- (2) X
- (3) Y
- (4) Z

(Go on to the next page)

- 12 Kenny set up an experiment as shown below. An iron ball was heated to  $90^{\circ}\text{C}$  and a ceramic ball was cooled to  $5^{\circ}\text{C}$ . They were then immediately placed into beaker A and beaker B as shown in the diagram below.

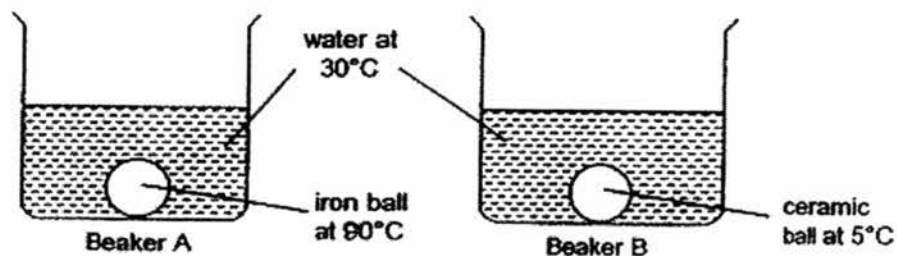

What would happen to the temperature of the water in both beakers in the next few minutes ?

	Temperature of water in Beaker A	Temperature of water in Beaker B
(1)	decrease	decrease
(2)	decrease	increase
(3)	increase	increase
(4)	increase	decrease

- 13 A, B, C and D were blobs of wax placed on a metal ring as shown in the diagram below.

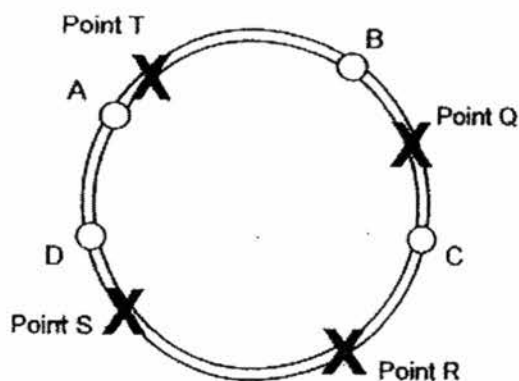

When the ring was heated at a certain point, the order in which the drops of wax melted was D, A, C and B. At which point, Q, R, S or T was the ring heated?

- (1) Point Q
- (2) Point R
- (3) Point S
- (4) Point T

(Go on to the next page)

- 14 Jason placed two cubes of different materials but of the same size on two identical springs. As a result, the springs were compressed as shown below.

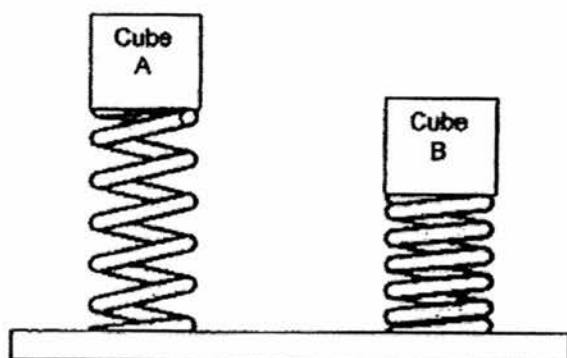

Based on his observation, Jason can conclude that \_\_\_\_\_.

- (1) Cube A is heavier than Cube B
  - (2) the compressed spring with Cube A has less elastic potential energy than the compressed spring with Cube B
  - (3) the compressed spring with Cube A has less gravitational potential energy than the compressed spring with Cube B
  - (4) the elastic potential energy in the compressed spring with Cube A will be converted to more kinetic energy than the compressed spring in Cube B
- 15 Study the diagram of a toy plane below.

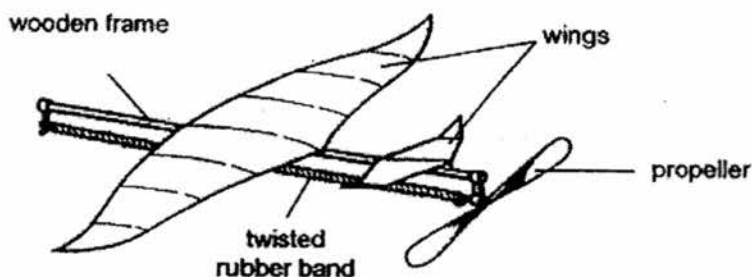

Which part of the toy plane possesses the source of energy which enables it to move when it is released?

- (1) Wings
- (2) Propeller
- (3) Wooden frame
- (4) Twisted Rubber band

(Go on to the next page)

- 16 Joe set up an experiment as shown below. When the steel paper clip moved towards the iron rod, Joe measured the angle  $z$  from the starting position as shown below.

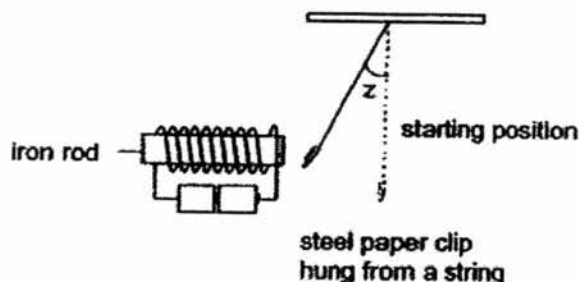

What changes to the experiment could Joe make to decrease angle  $z$ ?

- (1) Decrease the number of batteries.
  - (2) Move the circuit slightly to the right.
  - (3) Replace the steel paper clip with a lighter one.
  - (4) Increase the number of coils around the iron rod.
- 17 When a magnet is broken into two pieces, each piece will have its own poles. Kyle broke a bar magnet into three pieces as shown below.

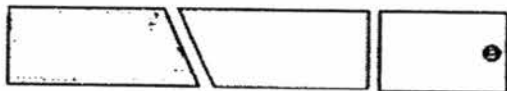

Each piece was brought near to another piece of the broken magnet. Which one of the following below is most likely correct?

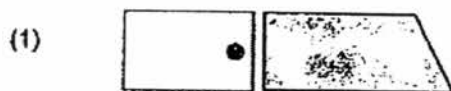

Attracted

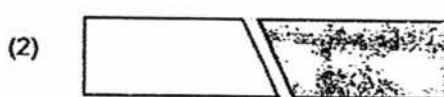

Repelled

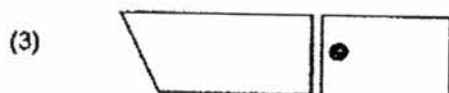

Attracted

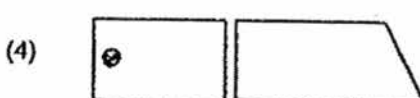

Repelled

(Go on to the next page)

- 18 Tom conducted an experiment using springs P and Q. He hung different loads at a time on each spring and recorded their lengths. The results are shown in the graph below.

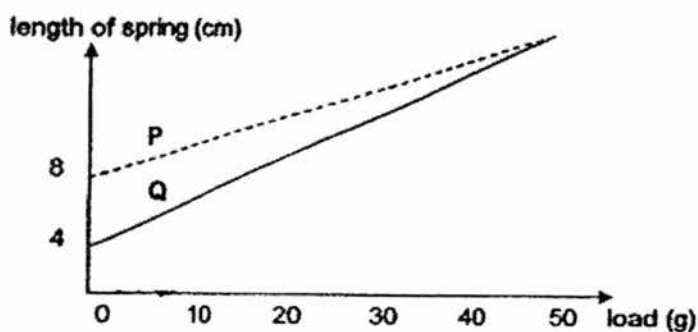

Which of these conclusions could Tom make based on his results?

	Spring that is longer at the start of the experiment	Spring that can be stretched more with the same load
(1)	Q	P
(2)	P	P
(3)	P	Q
(4)	Q	Q

- 19 An iron ball is rolled up an iron ramp which has a strong magnet attached on its underside as shown below.



Which of these forces is/are acting on the moving iron ball?

- A Gravity
  - B Friction
  - C Magnetic
  - D Weight of the ramp
- (1) C only
- (2) A and B only
- (3) B, C and D only
- (4) A, B, C and D

(Go on to the next page)

- 20 Gary wanted to find out the effect of water on photosynthesis. He used the same type of plants in each set-up. He listed the different conditions in his five set-ups as shown in the table below. A tick (✓) indicates that the set-up has the condition.

Condition	Set-up				
	A	B	C	D	E
Oxygen		✓	✓		✓
Carbon dioxide	✓	✓		✓	✓
Water	✓				✓
Fertilizer			✓		
Sunlight	✓	✓	✓		✓

Which two set-ups should be used to show that water is needed for the plant to make food?

- (1) A and D
  - (2) B and E
  - (3) C and D
  - (4) D and E
- 21 Study the food web below.

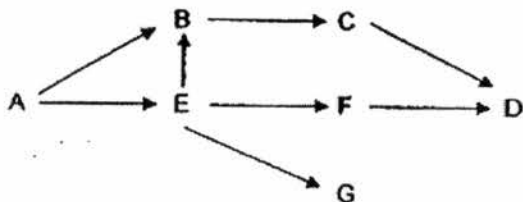

Based on the food web, which one of the following will cause a decrease in the population of F?

- (1) An increase in the population of A
- (2) An increase in the population of E
- (3) An increase in the population of G
- (4) A decrease in the population of D

(Go on to the next page)

- 22 Rio wanted to find out how fast water flow through different types of soil. He used the set-up below.

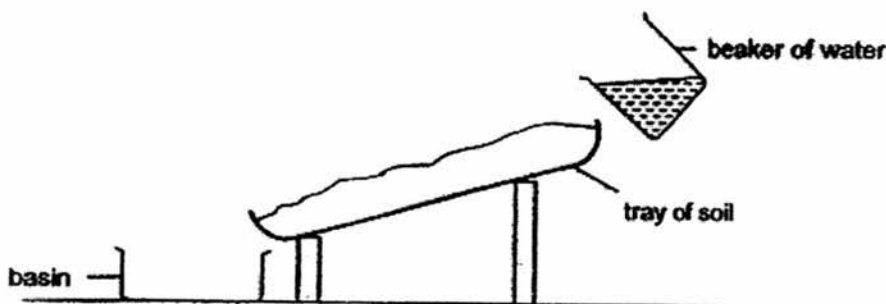

He poured 300 ml of water onto soil W at one end of the tray and allowed the water to flow into the basin. After 5 seconds, he measured the volume of the water collected in the basin. He repeated the experiment with soil X, Y and Z. The graph below shows the results of the experiment.

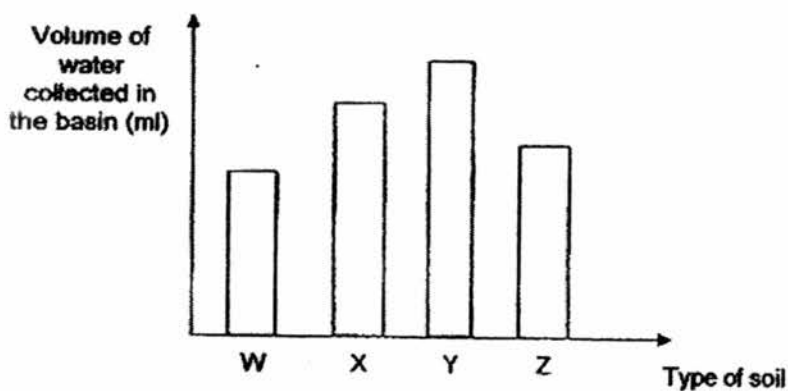

Rio wanted to plant a cactus which requires soil that allows water to pass through easily. Which soil is the most suitable for the cactus to grow in?

- (1) W
- (2) X
- (3) Y
- (4) Z

- 23 The diagrams below show the life cycles of insects P and Q.

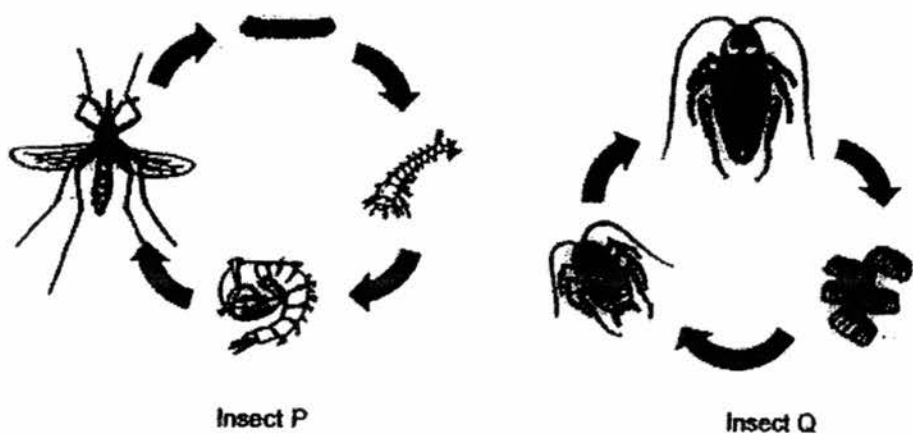

Based on the diagrams above only, which of the following statements about insects P and Q is/are true?

- A Both adults lay eggs.
- B Both adults do not have wings.
- C Insect P lives longer than insect Q.
- D Both their young looks like their adult.

- (1) A only
- (2) A and C only
- (3) B and C only
- (4) B and D only

- 24 The four statements A, B, C and D below describe the processes of plant reproduction.

- A The male sex cell fuses with the female sex cell.
- B When water is present, the roots of the seeds will appear first.
- C The fruit splits open and the seeds are carried away by the wind.
- D When the insects collect the nectar, they also transfer pollen grains to the flower.

In which order does the process of plant reproduction occur within one cycle?

- (1) A, C, B, D
- (2) B, A, C, D
- (3) A, B, C, D
- (4) D, B, C, A

(Go on to the next page)



- 25 The diagram below shows the water cycle.

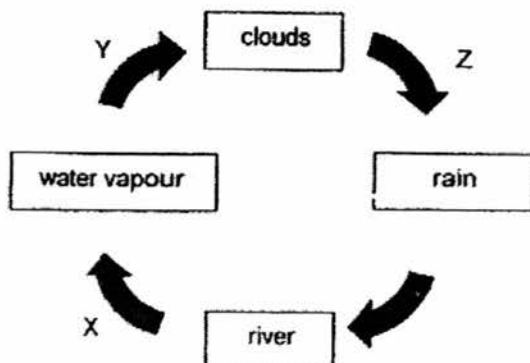

Which of the following statement(s) about the water cycle is/are correct?

- A At stage Y, the water vapour loses heat to the surroundings.  
 B At stage X, the water in the river loses heat to the surroundings.  
 C At stage Z, the clouds gained heat from the surroundings to form rain.

- (1) A only  
 (2) B only  
 (3) A and B only  
 (4) A and C only

- 26 The table below shows how the various parts, A, B, C, and D, of the reproductive system in a human and a plant are similar in their function.

	Reproductive System	
	Human	Plant
A	egg	X
B	ovary	ovary
C	Y	pollen grain
D	Z	anther

Which one of the following shows the correct representation of X, Y and Z?

	X	Y	Z
(1)	ovule	sperm	testes
(2)	seed	sperm	testes
(3)	ovule	testes	penis
(4)	seed	testes	penis

(Go on to the next page)

- 27 The diagram below shows a pump connected to a sealed container, with a capacity of  $500 \text{ cm}^3$  through a thin tube. A block of metal with a volume of  $30 \text{ cm}^3$  was placed inside the container.

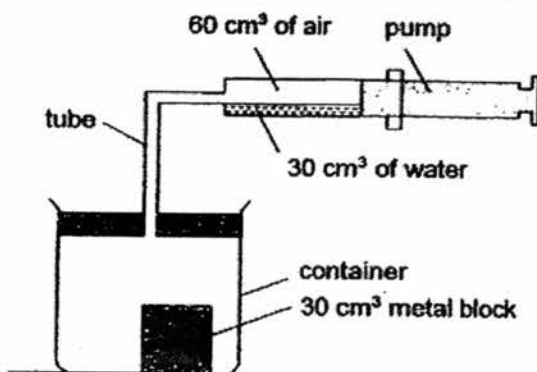

When the pump was completely pushed in, the  $30 \text{ cm}^3$  of water and  $60 \text{ cm}^3$  of air was forced into the container.

What would be the final volume of the air inside the container?

- (1)  $120 \text{ cm}^3$
  - (2)  $380 \text{ cm}^3$
  - (3)  $440 \text{ cm}^3$
  - (4)  $470 \text{ cm}^3$
- 28 The diagram below shows a water bird which catches and feeds on fish.

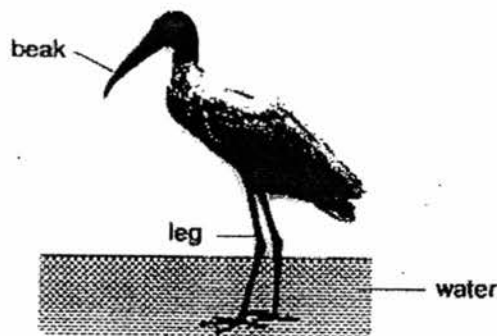

Based on the diagram above, which one of the following adaptations of the bird does not match the function for catching fish?

	Adaptation	Function
(1)	Beak	To help it grab fish.
(2)	Long beak	To help it reach into the water to catch fish.
(3)	Long legs	To keep its feathers dry for flying.
(4)	Thin legs	To make it look like tree branches so they can avoid being detected by fish.

(Go on to the next page)

- 29 Melissa heated a substance for 30 minutes and measured its temperature during that 30 minutes at one-minute intervals. She plotted her results in a graph as shown below.

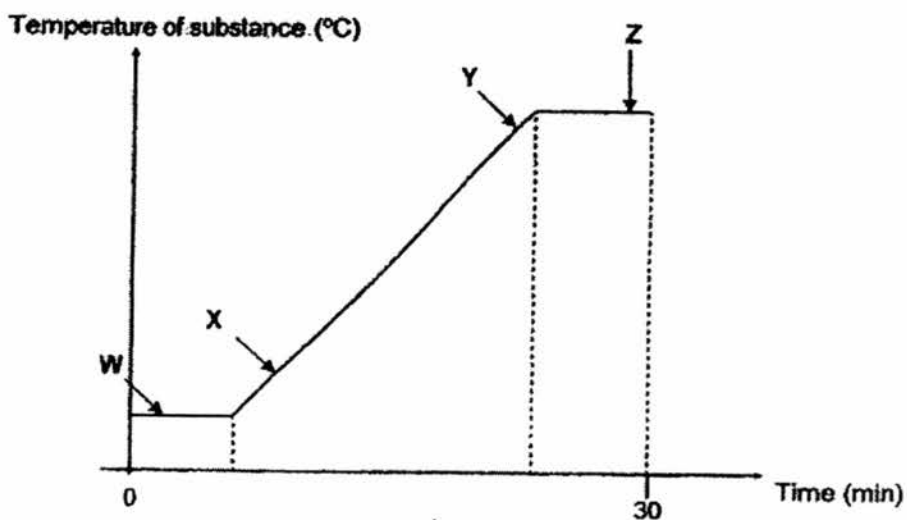

Based on the graph above, which of the following statements are true?

- A The substance is at the same state at points W and X.
- B The substance is at the same state at points X and Y.
- C The substance loses heat to the surroundings at point W.
- D The substance continues to gain heat from the heat source at point Z.

- (1) A and B only
- (2) B and C only
- (3) B and D only
- (4) A, C and D only

- 30 The diagram below shows Mary's family tree. A key to show the presence of the physical characteristic of dimples for the different family members is given.

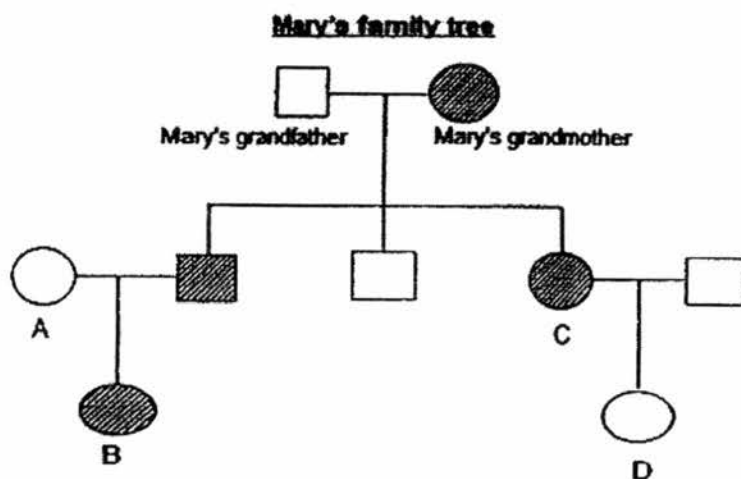
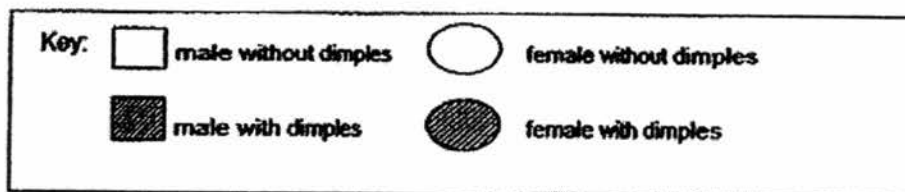

Which one of the following, A, B, C or D, best represents Mary in the family tree if Mary has dimples?

- (1) A
- (2) B
- (3) C
- (4) D

Index No:

--	--	--	--	--	--



Anglo-Chinese School (Junior)  
Anglo-Chinese School (Primary)

**PRELIMINARY EXAMINATION 2016  
SCIENCE  
BOOKLET B  
PRIMARY SIX**

Name: \_\_\_\_\_ (   )

Class: Primary 6

Date: 25 August 2016

Duration of paper: 1 h 45 min

\_\_\_\_\_  
Parent's/Guardian's Signature

**INSTRUCTIONS TO CANDIDATES**

1. Write your name, register number and class.
2. Do not turn this page until you are told to do so.
3. Follow all instructions carefully.
4. Answer all questions.
5. Write your answers in this booklet.
6. This question paper consists of 17 printed pages including this cover page.

BOOKLET	POSSIBLE MARKS	MARKS OBTAINED
A	60	
B	40	
Total	100	

**PART II**

For questions 31 to 44, write your answers in this booklet.

The number of marks available is shown in brackets [ ] at the end of each question or part question.

(40 marks)

- 31 Ravi wanted to find out which material, X or Y, would be more suitable to hang clothes to dry. He hung the two poles of the same mass and size as shown below.

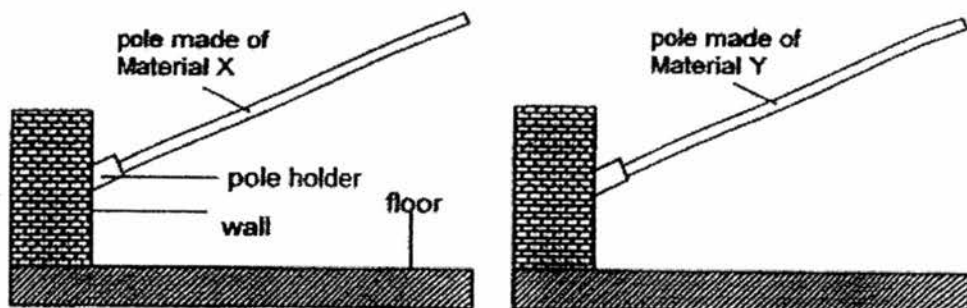

He then hung a 10 kg weight on each pole and the result is shown below.

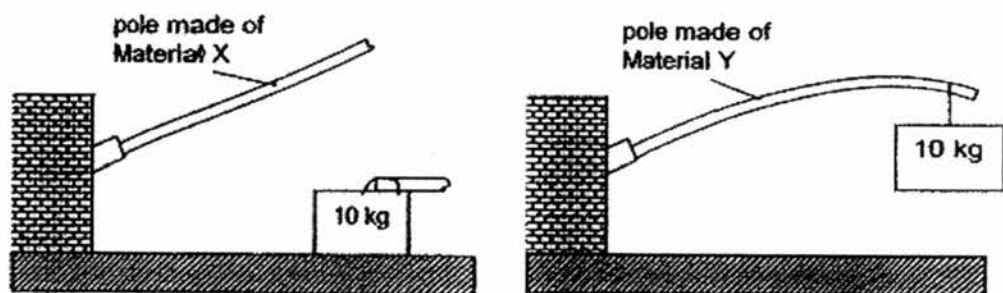

- (a) Based on the results, what property of the material was Ravi testing? [1]
- \_\_\_\_\_
- (b) What two variables must Ravi keep the same while conducting the experiment? [1]
- \_\_\_\_\_
- \_\_\_\_\_
- (c) Ravi wanted to use either pole X or Y for fishing instead of for hanging clothes. Based on the results above, which material, X or Y, is more suitable to be used as a fishing pole? Explain your answer. [1]
- \_\_\_\_\_
- \_\_\_\_\_

(Go on to the next page)

SCORE	/
	3

\_\_\_\_\_

\_\_\_\_\_

(c) Alex wanted to make the drop of ink in Flask A to rise even higher than Tom's. Using only his hands, what can Alex do to achieve this? [1]

\_\_\_\_\_

\_\_\_\_\_

(b) Explain why the drop of ink in Flask B did not move. [1]

\_\_\_\_\_

\_\_\_\_\_

(a) Why did the drop of ink in Flask A eventually rise when Tom was holding it? [1]

When Tom held Flask A for 5 minutes, he observed that the drop of ink in the tube moved downwards and then rose upwards, but when he held Flask B for the same amount of time, the drop of ink in the tube did not move.

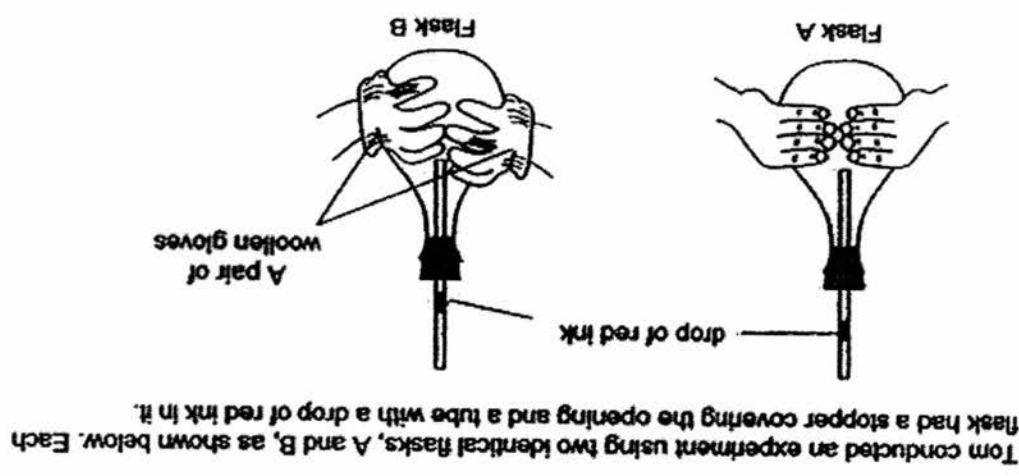

32 Tom conducted an experiment using two identical flasks, A and B, as shown below. Each flask had a stopper covering the opening and a tube with a drop of red ink in it.

- 33 Dave conducted an experiment to find out the relationship between the height at which a wooden ball is released and the height at which an eraser can reach. When the wooden ball was released, it fell and hit the balance scale at point X. The balance scale then tilted downwards and caused the eraser to launch upwards.

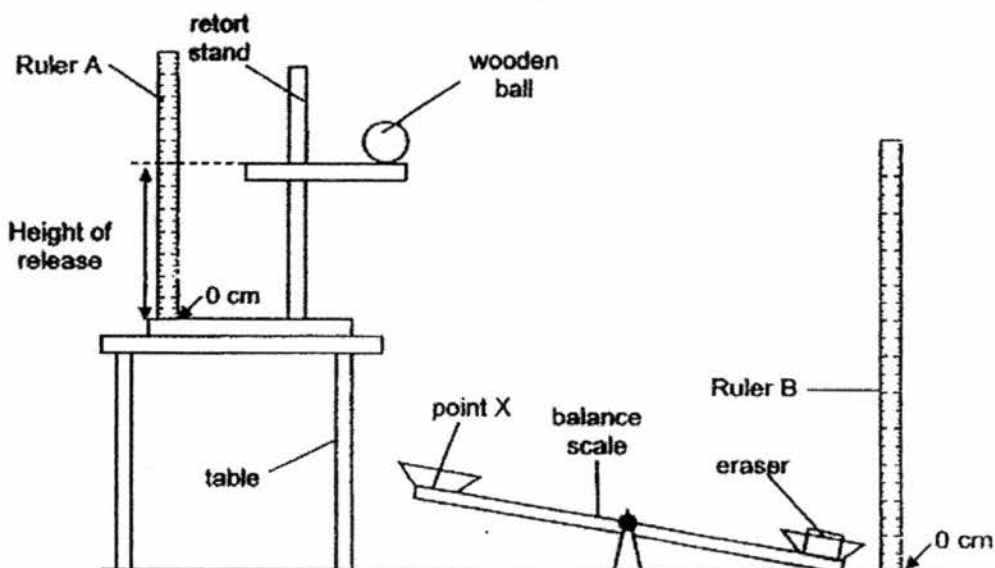

- (a) Identify the form(s) of energy that the wooden ball had:

[1]

- i) just before it was released.

---

- ii) when it hit the balance scale at point X.

---

(This question continues on page 5.)

(Go on to the next page)

SCORE	/
	1



- (b) Dave plotted the results on a graph shown below.

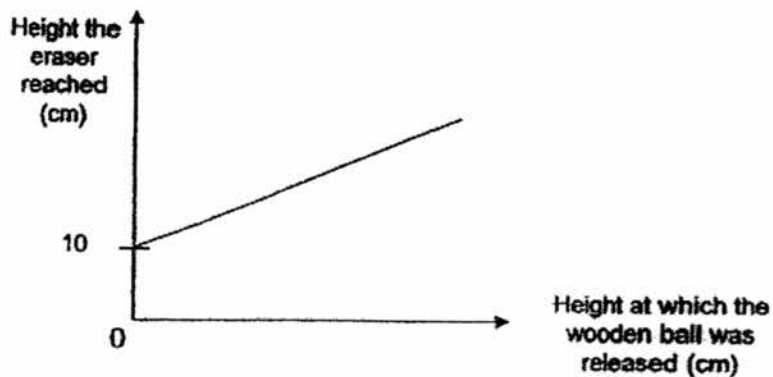

- i) Based on the graph, what can Dave conclude about the relationship between the height at which the wooden ball was released and the height at which the eraser reached? [1]

---



---

- ii) When the wooden ball was released from a height of 0 cm as indicated on Ruler A, the eraser was able to reach a height of 10 cm on Ruler B. Explain why. [1]

---



---



---

(Go on to the next page)

SCORE	/
	2

- 34 Jared wanted to find out if the amount of roots a plant has affects the amount of water it can absorb. He carried out an experiment using the set-up shown below.

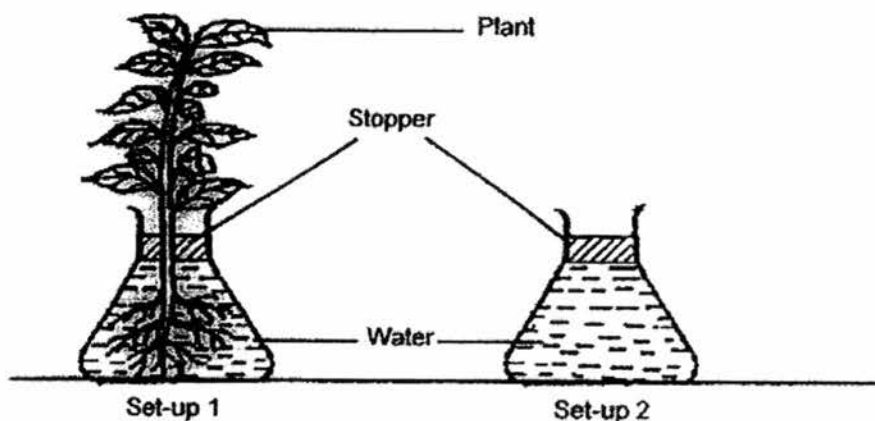

He left the set-up undisturbed for two days in the garden. The amount of water only decreased in Set-up 1.

- (a) What is the function of the stopper? [1]

---



---

- (b) Why did the volume of water in Set-up 1 decrease after two days? [1]

---



---

(Go on to the next page)

SCORE	/
	2

- 35 Mr Tan went overseas for a week. When he returned, he observed that his plant had wilted as shown below.



When a plant is wilting, the stomata on the leaves either close or reduce the size of their openings.

- (a) How does the closing of the stomata help the wilting plant stay alive? [1]

---

---

- (b) The rate of photosynthesis of the plant decreases when the plant is wilting. Give two reasons for this. [2]

---

---

---

---

(Go on to the next page)

SCORE	
	3

- 36 Jared wanted to find out if the colour of the light affects the rate of photosynthesis. He set up the experiment in a dark room with a torchlight producing white light. The number of oxygen bubbles produced by Plant T in ten minutes was counted. The experiment was then repeated, with the torch wrapped with a transparent blue plastic sheet giving out blue light.

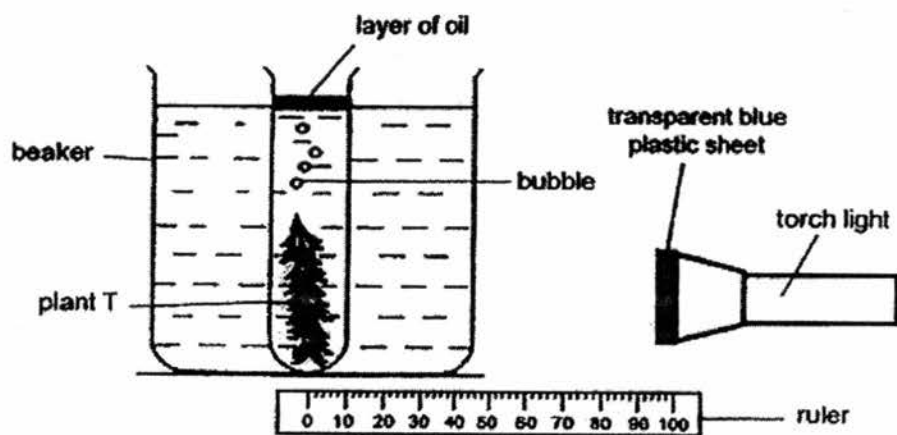

Jared's readings are as shown below.

	Number of bubbles produced in 10 minutes		
	1 <sup>st</sup> try	2 <sup>nd</sup> try	3 <sup>rd</sup> try
White light	6	5	6
Blue light	4	4	4

- (a) Jared used the same Plant T throughout the experiment. Give a reason why using the same plant helps to make the experiment a fair test. [1]

---



---

- (b) What can Jared do to increase the number of bubbles produced by Plant T? [1]

---



---

- (c) Jared wanted to find out if the temperature of water would affect the rate of photosynthesis for Plant T. Apart from using the same plant, suggest two other variables that he has to keep constant when conducting his experiment. [1]

---



---

(Go on to the next page)

SCORE	
	3

- 37 Kathy set up the circuit below with new bulbs and batteries. She connected four objects W, X, Y and Z to the electrical circuit as shown below. Bulbs B1, B2, B4 lit up while B3 did not.

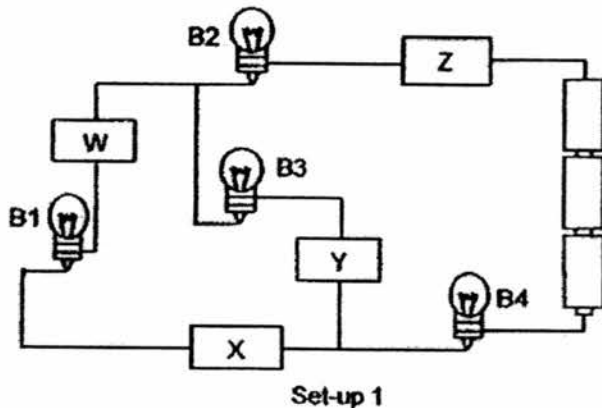

She then shifted the position of the objects W, X, Y and Z as shown below.

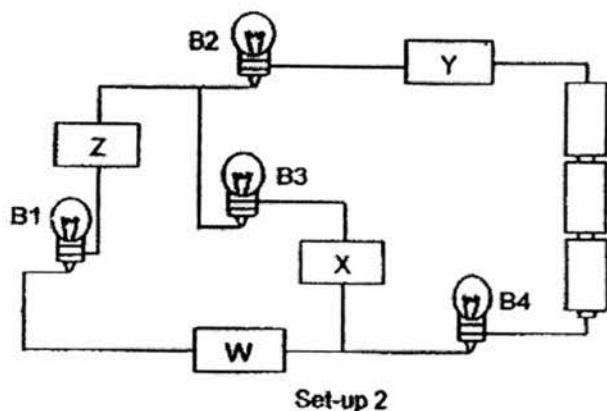

- (a) Which bulb(s) would light up in Set-up 2? Explain your answer. [2]

---



---

- (b) Give an example of a type of material that objects Y and Z could be made of. [1]

(i) Y: \_\_\_\_\_

(ii) Z: \_\_\_\_\_

(Go on to the next page)

SCORE	3

- 38 The diagram below shows an experimental set-up. It is made up of two sealed beakers of the same size, each containing 500 ml of water at 50°C at the start of the experiment. Beaker B is wrapped with a layer of wet cotton wool.

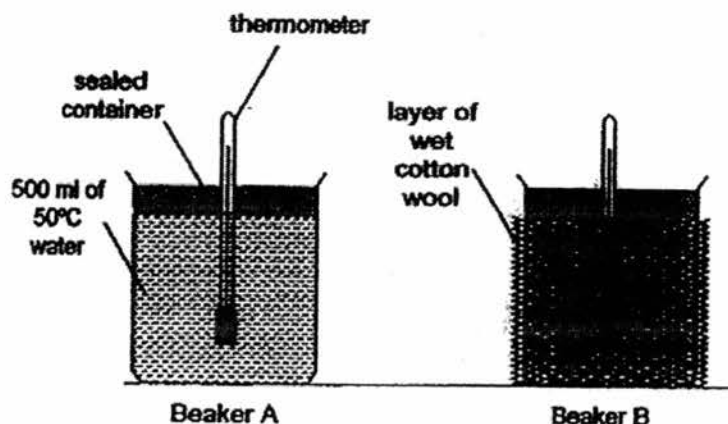

The temperatures of the water in the beakers were measured at regular intervals and the results tabulated as shown below.

Beaker	Temperature (°C)				
	5 min	10 min	15 min	20 min	25 min
A	50	45	40	38	35
B	50	43	39	35	30

- (a) Beaker A was used as a control set-up. Explain the purpose of the control set-up in this experiment. [1]

---



---

- (b) Explain how the layer of wet cotton wool helped the water in beaker B to reach a lower temperature than beaker A at the end of the experiment. [1]

---



---

(This question continues on page 11.)

(Go on to the next page)

SCORE	2

- 38 A polar bear has a layer of fur to help keep it warm in a cold environment. When the polar bear climbs onto dry land after a swim in the ocean, it shakes its entire body to remove the water trapped in its fur, as shown below.



Picture taken from <http://www.telegraph.co.uk/>

- (c) Explain how this behavioural adaptation helps the polar bear in keeping warm. [1]

---

---

(Go on to the next page)

SCORE	/
	1

- 39 The diagram below shows a water container with fan blades and nozzles attached to it.

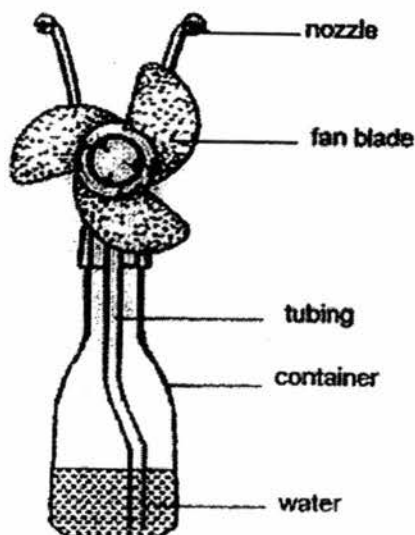

Water in the container is being transported through the tubing to the nozzles, which sprays out the water in the form of 'fine mist'.

- (a) When the 'fine mist' is being sprayed into the air, the surrounding air becomes cooler. Explain why this is so. [1]

---



---

The fan blades on the device are made of rubber and they will start turning only when the user presses a switch on the container.

- (b) Explain how switching on the device helps to make the surrounding air cool faster. [1]

---



---

- (c) Without making any changes to the device, state one method which can make the device cool the surrounding air even faster. [1]

---



---

(Go on to the next page)

SCORE	
	3



40 The diagrams below show a seedling at two different stages in its life cycle.

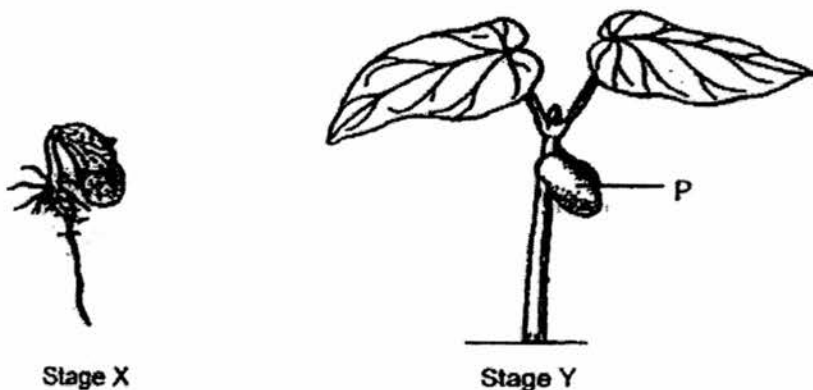

- (a) Which of the following factors below will allow the original seed to develop into stage X? Put a tick (✓) beside the correct factors. [1]

Factors	Tick (✓)
Presence of water	
Presence of oxygen	
Presence of carbon dioxide	
Presence of nutrients	
Presence of light	
Presence of heat	

- (b) Identify part P. [1]

---

- (c) Explain why part P becomes smaller as the leaves of the seedlings become bigger. [1]

---



---

(Go on to the next page)

SCORE	
	3

- 41 Roy conducted an experiment as shown below. He placed a magnet at one end of surface A and placed a steel ball at the other end and observed what happened.

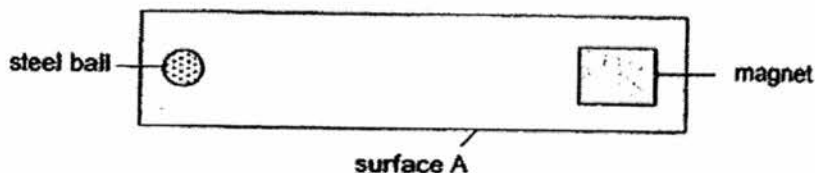

Roy repeated the experiment using the same magnet and steel ball but with surface B. He recorded his observations in the table below.

Surface	Time taken for the steel ball to be attracted to the magnet (s)		
	Try 1	Try 2	Try 3
Surface A	1.2	1.0	1.2
Surface B	1.3	1.2	1.3

- (a) Based on the results, which surface was smoother? Explain why. [1]

---



---

- (b) What will happen to the time taken when lubricant is applied on the surfaces? Explain why. [2]

---



---



---

(Go on to the next page)

SCORE	3
-------	---

- 42 George wanted to find out if the survival of submerged plants would be affected by the presence of floating plants.

George used identical glass containers with the same amount of water. He also used the same type and amount of submerged plants. He placed the set-ups below by the window.

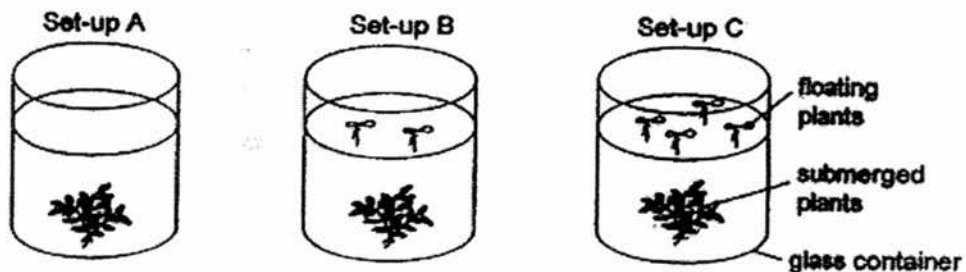

After three days, all the submerged plants were still alive.

How can George improve his set-ups or experiment so that he can observe an effect on the submerged plants? [2]

Improvement 1:

---



---

Improvement 2:

---



---

(Go on to the next page)

SCORE	/
	2

- 43 Gareth wanted to find out how fast different types of wood could burn. He used the set-up as shown below. Once he had lit up the wood, he quickly covered the container with the lid and made his observations. He repeated his experiment with the other types of wood.

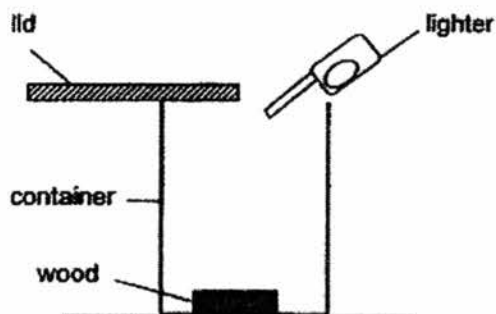

- (a) Gareth repeated the experiment with the wood being broken into smaller pieces. He observed that the small pieces of wood burnt faster. Explain why. [1]

---



---



---

- (b) Give one example of a pollutant released into the surrounding air as a result of deforestation by burning. [1]

---

- (c) Deforestation by burning causes global warming. Explain how. [1]

---



---

(Go on to the next page)

SCORE	/
	3

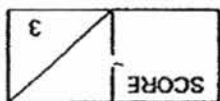

End of Paper

(c) Which organism(s) is/are both a prey and a predator? [1]

(b) How many food chains are there? [1]

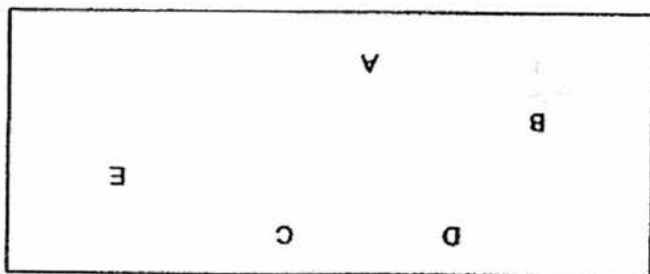

(a) Draw the correct arrows to complete the food web below using the information above. [1]

C is eaten by B and E.  
D is eaten by B and C.  
A eats B and E.

44 A, B, C, D and E are five living things in a community. The following statements show the food relationships between the five organisms.