

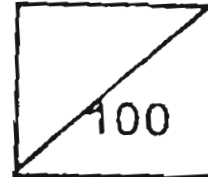

SA2

Rosyth School  
Preliminary Examinations for 2005  
SCIENCE  
Primary 6 (EM1/2)

Total  
Marks:



Name: \_\_\_\_\_

Class: Pr 6 \_\_\_\_\_ Register No. \_\_\_\_\_ Duration: 1 h 45 mins

Date: 25.8.05 Parent's Signature: \_\_\_\_\_

---

## Booklet A

### Instructions to Pupils:

1. Do not open the booklets A and/or B until you are told to do so.
2. Follow all instructions carefully.
3. This paper consists of 2 booklets, A and B.
4. For questions 1 to 30 in Booklet A, shade the correct ovals on the Optical Answer Sheet (OAS) provided using a 2B pencil.
5. For questions 31 to 46, give your answers in the spaces given in the Booklet B.

	Maximum	Marks Obtained
Booklet A	60 marks	
Booklet B	40 marks	
Total	100 marks	

\* This booklet consists of 18 pages . (Pg. 1 to 18)

This paper is not to be reproduced in part or whole without the permission of the Principal.

**PART I (60 marks)**

For each question from 1 to 30, four options are given. One of them is the correct answer. Make your choice (1, 2, 3 or 4). **Shade the correct oval (1, 2, 3 or 4) on the Optical Answer Sheet.**

1. Study the classification chart below.

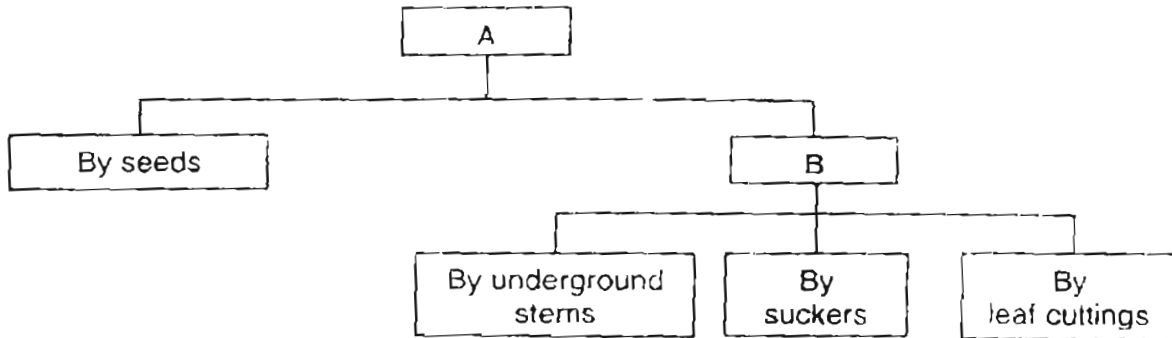

Which of the following can Headers A and B be?

	Header A	Header B
(1)	Plants and Plant Parts	By edible plant parts
(2)	Dispersal of Fruits	By wind
(3)	Reproduction in Plants	By plant parts
(4)	Flowering and Non-Flowering plants	By spores

2. The table below shows the properties of four materials, W, X, Y and Z.

Properties \ Materials	W	X	Y	Z
Can it conduct heat easily?	No	No	No	Yes
Can it bend?	Yes	No	Yes	Yes
Can it be attracted to a magnet?	No	No	No	Yes
Can it break into pieces when dropped?	No	Yes	No	No
Is it waterproof?	No	Yes	Yes	Yes

Which of the materials if made into a toy would be most dangerous for a baby to play with?

- (1) W
- (2) X
- (3) Y
- (4) Z

3. The diagram below shows the life cycle of a string bean plant.

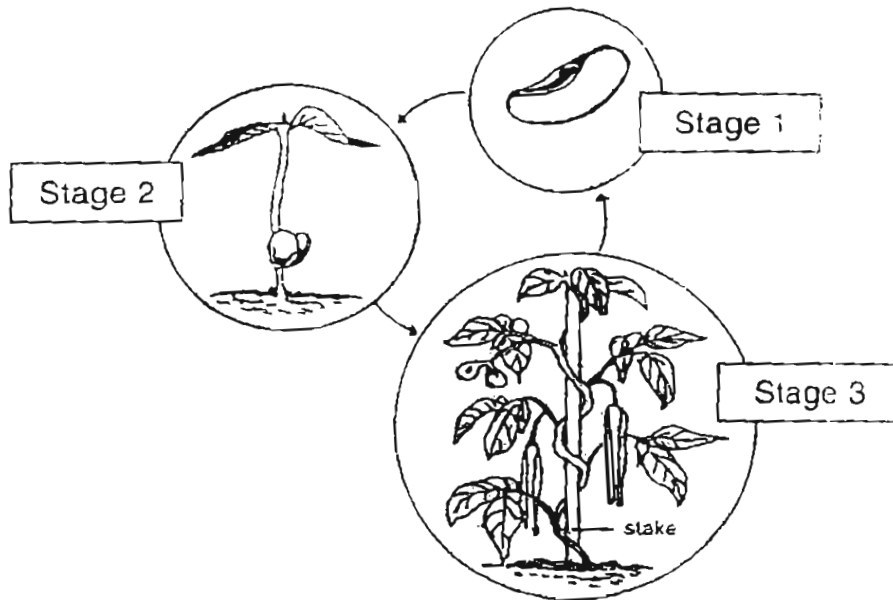

Which of the following statement(s) is/are incorrect?

- A: The growth of a string bean plant is called its life cycle because in stage 3, the string bean plant grows round and round the stake.
- B: Sunlight is required for all the stages of growth.
- C: Before the seedling can make its own food, it gets its food from the seed.
- D: The string bean plant goes through a life cycle so that there will be new string bean plants on Earth after the old ones die

- (1) A only
- (2) A and B only
- (3) C and D only
- (4) B, C and D only



6. Study the diagram below.

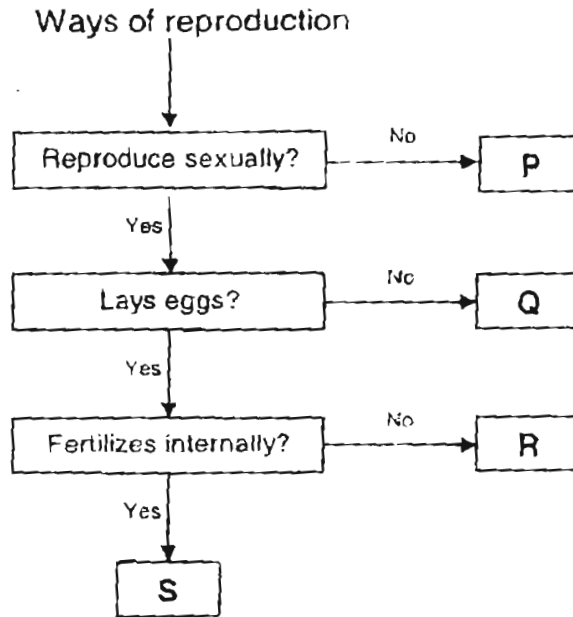

Which letters in the diagram represent the frog and the paramecium correctly?

	Frog	Paramecium
(1)	R	S
(2)	P	R
(3)	S	P
(4)	R	P

7. In an experiment, a marble was dropped into a displacement can as shown in the diagram below and exactly 4ml of water was displaced.

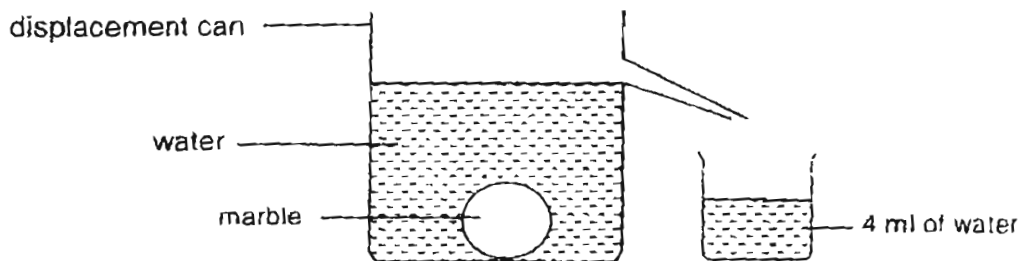

If vinegar was used instead of water in the displacement can and the same marble was dropped in, how much vinegar would have been displaced?

- (1) less than 4ml                      (2) 4ml  
 (3) more than 4ml                    (4) cannot be determined

8. Which of the following shows the position of the Sun at 3pm?

(1)

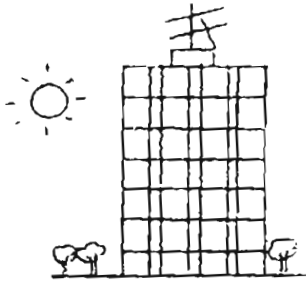

(2)

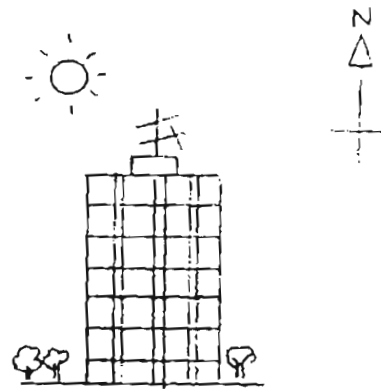

(3)

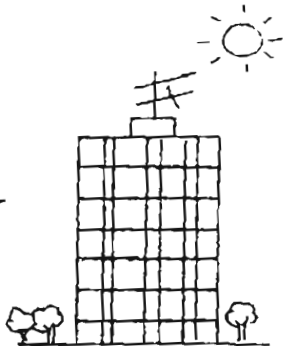

(4)

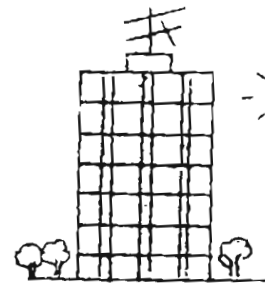

9. The diagram below shows a glass of water filled to the brim with some ice cubes floating in it.

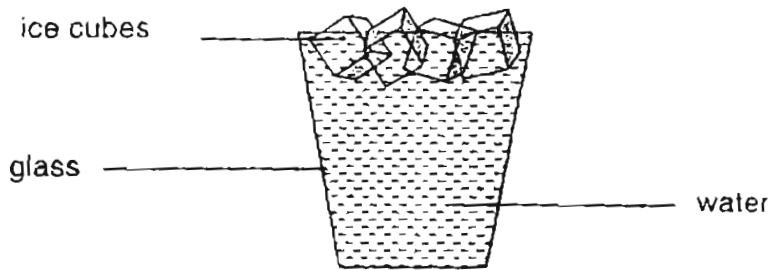

When all the ice cubes melt, which of the following will happen?

	Volume of contents in the glass	The water in the glass will
(1)	decrease	overflow
(2)	increase	overflow
(3)	decrease	not overflow
(4)	remain the same	not overflow

10. Which one of the following does not describe the function of the plant part correctly?

	Plant Parts	Function
(1)	Roots	Absorb water and mineral salts
(2)	Stem	Transports water and food
(3)	Leaves	Make food
(4)	Fruits	Grow into a young plant

11. The diagram below shows the human digestive system.

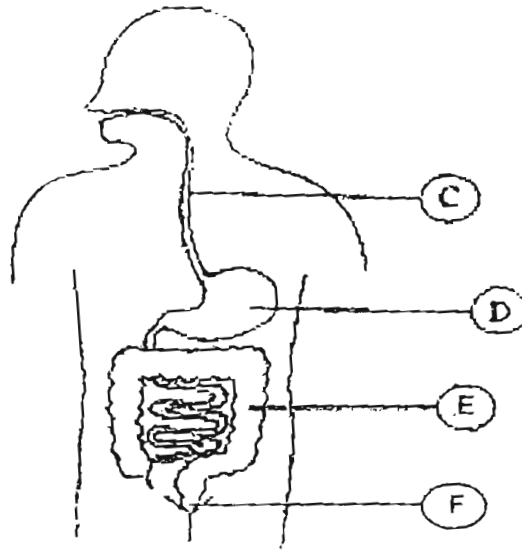

Which one of the following statements is true?

- (1) Digestion only starts at D.
- (2) C is known as the windpipe.
- (3) There are digestive juices at F.
- (4) Water is removed from undigested food in E.

12. Study the diagram below.

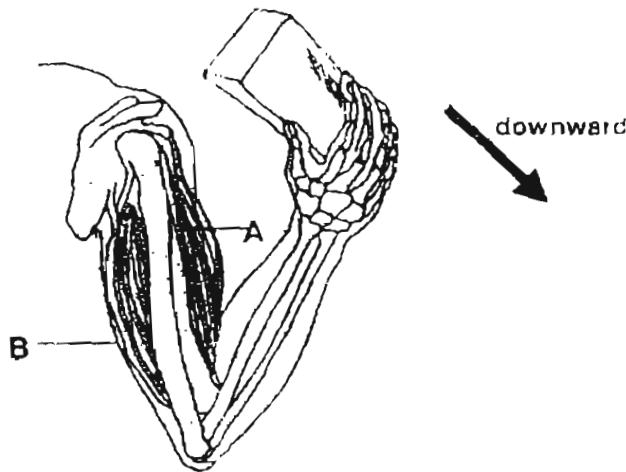

Which of the following sets of muscle action would allow the arm to move downwards?

	Muscle A	Muscle B
(1)	relax	relax
(2)	contract	contract
(3)	relax	contract
(4)	contract	relax

13. A cell in the human body requires oxygen and glucose to carry out respiration to release energy. For oxygen to get to all the cells in the body, which one of the following is the path it takes?

- (1) nose → gullet → small intestine → blood → all parts of the body
- (2) mouth → gullet → lungs → blood → all parts of the body
- (3) nose → windpipe → lungs → blood → all parts of the body
- (4) mouth → windpipe → heart → small intestine → all parts of the body





14. In which one of the following circuits will the bulb not light up?

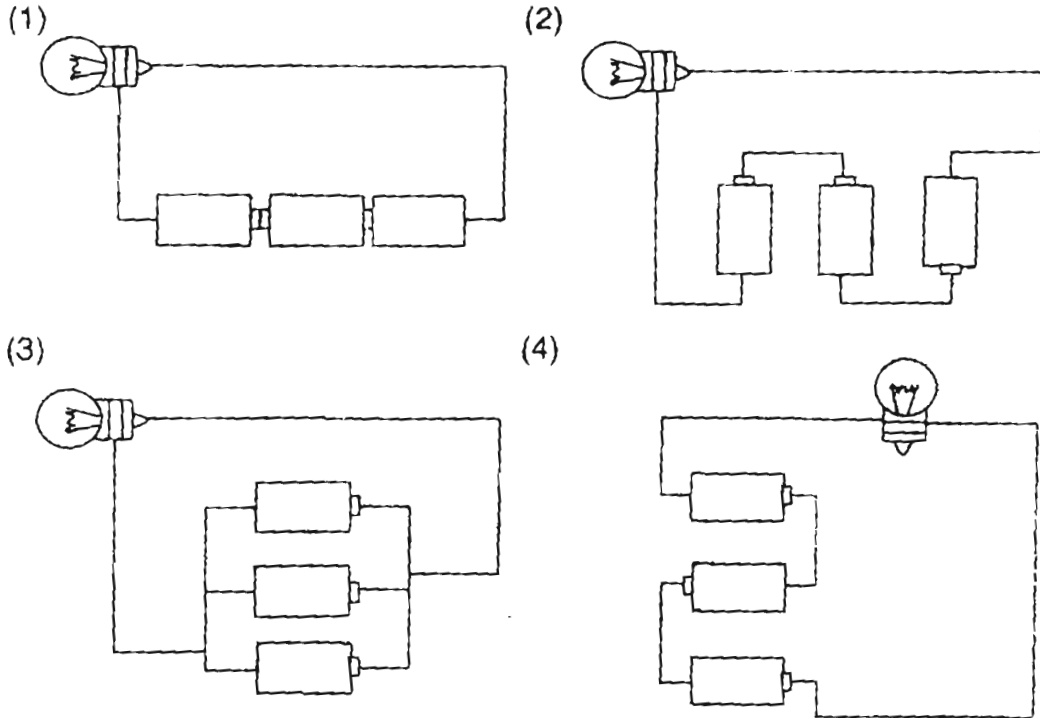

15. The bulb lights up in the circuit shown below.

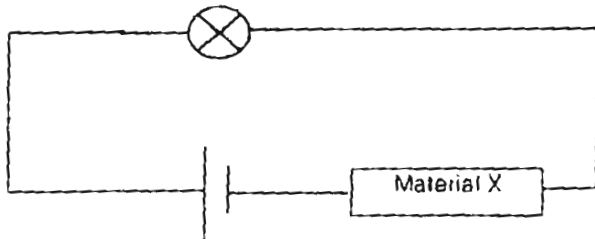

Which of the following statements about Material X is therefore true?





- (1) It must be an electrical conductor and a good conductor of heat.
- (2) It must be a conductor of electricity.
- (3) It must be made of metal.
- (4) It must be flexible.

16. The stem of a cactus plant is thick, green and waxy.  
How do these features of the stem help the plant to adapt to the conditions of a desert?

- A: It helps to store water.
- B: It helps to make food.
- C: It helps to reduce water loss to the surroundings.
- D: It helps to anchor the plant firmly in the sandy soil.

- (1) A and B only
- (2) C and D only
- (3) A, B and C only
- (4) A, B, C and D

17. Mei Li classified some fruits she collected into two groups based on their method of dispersal as shown below.

Method of Dispersal	
Group A	Group B
 Shorea	 Flame of the forest
 Angsana	 Balsam

Later, she found another fruit that she tried to classify but she realized that it could be placed in both groups A and B.

Which one of the following fruit can be placed in both groups?

(1)

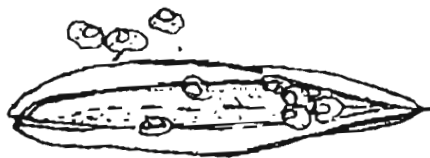

African Tulip

(2)

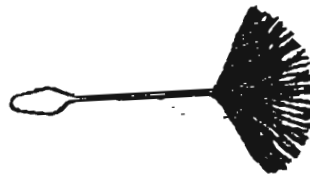

Cupid's Shaving Brush

(3)



Elephant Grass

(4)

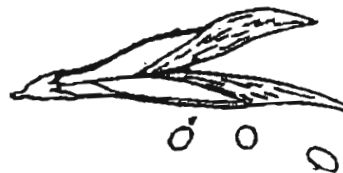

Snow Pea

18. Which of the following are harmful effects of deforestation?

- A: Soil erosion
- B: Global warming
- C: Loss of living things
- D: Pollution of water bodies

- (1) A and D only
- (2) B and C only
- (3) B, C and D only
- (4) A, B, C and D

19. Sam carried out the following steps (i) to (iv) to produce creamy yoghurt from milk.

- (i) Warm the milk to about 80 °C.
- (ii) Continue to warm for 5 seconds.
- (iii) Cool it to 45 °C.
- (iv) Ferment it at 40 °C for about 3 hours.

During which step (i, ii, iii or iv) must Sam add the bacteria required to produce yoghurt?

- (1) i
- (2) ii
- (3) iii
- (4) iv

20. A strong magnet was lowered onto a heap of pins and then lifted. The diagram below shows how the pins were attracted to the magnet.

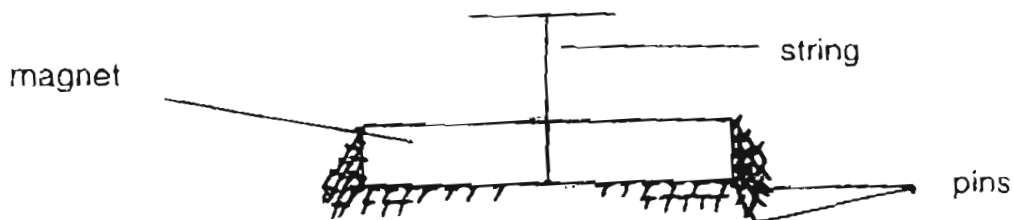

Which of the following deductions can be made from the above experiment?

- A: The strong magnet is made of iron and steel.
- B: The pins attracted are made of magnetic material.
- C: There are more pins attracted to the poles than the centre of the magnet.
- D: The pulling forces at the poles are stronger than the other parts of the magnet.

- (1) A and C only
- (2) A and D only
- (3) B and C only
- (4) B and D only



22. Sarah set up the apparatus to conduct her experiment as shown below.

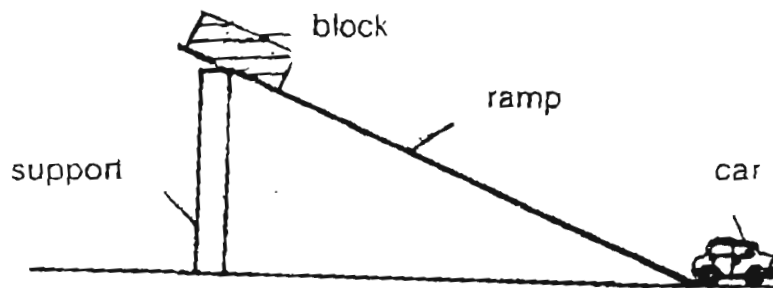

She wanted to find out whether the mass and surface texture of the block would affect the distance moved by the toy car.

She was given four wooden blocks with different masses and surface textures. The four wooden blocks are as shown below.

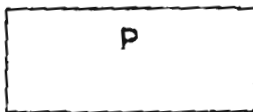

Surface texture: rough  
Mass: 40 grams

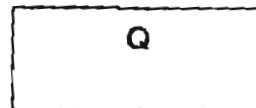

Surface texture: rough  
Mass: 80 grams

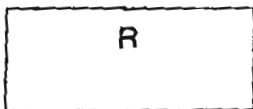

Surface texture: smooth  
Mass: 80 grams

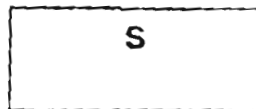

Surface texture: rough  
Mass: 100 grams

Sarah decided to choose three of the four blocks to conduct her experiment.

Which of the three blocks can she use to investigate her experiment?

- A: P, Q and R
- B: P, R and S
- C: P, Q and S
- D: R, Q and S

- (1) A and B
- (3) B and C

- (2) A and D
- (4) B and D

23. Block M is a bar magnet. It was placed on a glass table as shown below. The block was given a push to move along the table.

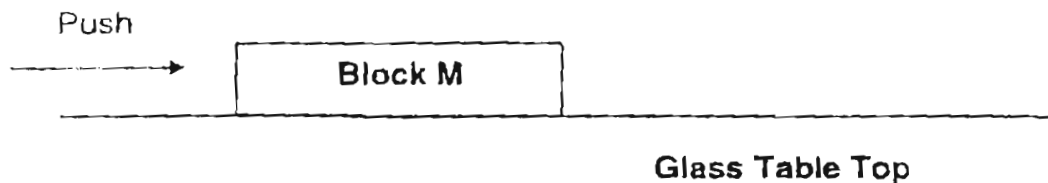

The following are different types of forces that can act on an object.

- A: Magnetic force
- B: Frictional force
- C: Gravitational force

Which of the following force or forces must the push overcome in order for the Block M to move along the table?

- (1) A only
- (2) B only
- (3) B and C only
- (4) A and C only

Refer to the two simple machines, M and N to answer questions 24 and 25.

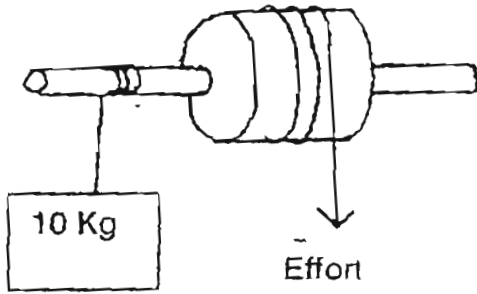

Machine M

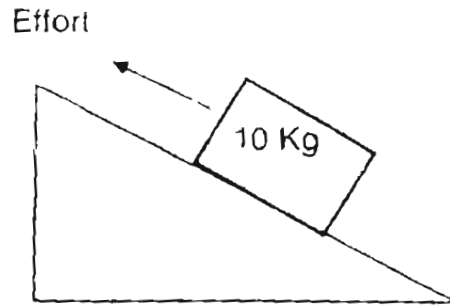

Machine N

24. What are the similarities between simple machines M and N?

- A: Both machines have the load moving up.
- B: Both machines change the direction of force applied.
- C: In both machines the effort travels more than the load.
- D: In both machines the effort required is less than the load.

- (1) A and C only
- (2) B and D only
- (3) A, C and D only
- (4) B, C and D only

25. A machine that is made of two or more simple machines is called a compound machine.  
In which one of the following compound machines are the two simple machines M and N used?

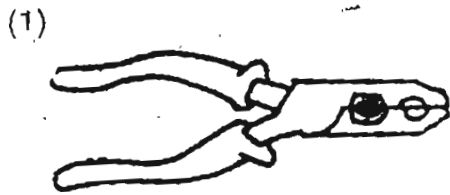

plier

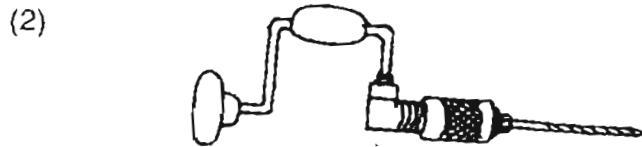

hand drill

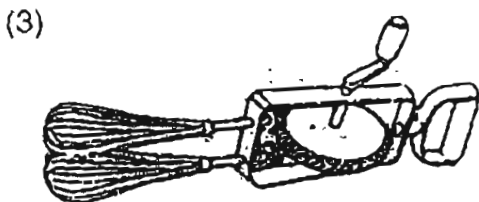

egg beater

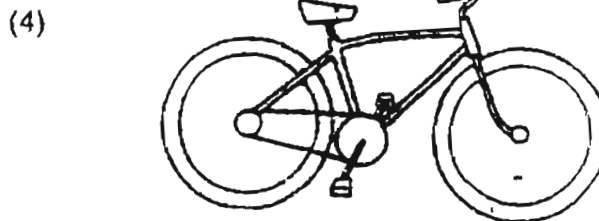

bicycle

26. Adam wanted to show that carbon dioxide is given out during respiration by plants. He set up an experiment as shown in the diagram below.

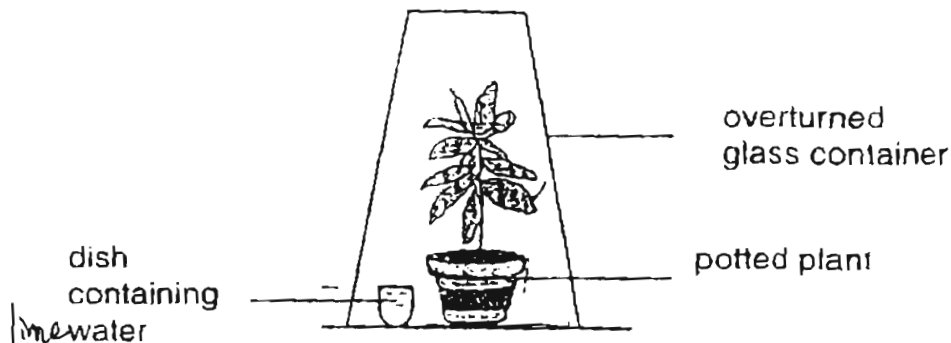

He left the set up in the cupboard for two days. The limewater in the dish turned chalky to show the presence of carbon dioxide in the overturned glass container. He concluded that carbon dioxide is given out during respiration by plants.

His teacher told him that he must set up a control in his experiment to prove that the plant gives out carbon dioxide during respiration.

Which one of the followings is the best control to prove that the plant gives out carbon dioxide during respiration?

(1) (2)

(3) (4)



27. A plant was placed in an enclosed bottle as shown below. It was able to survive in the closed environment.

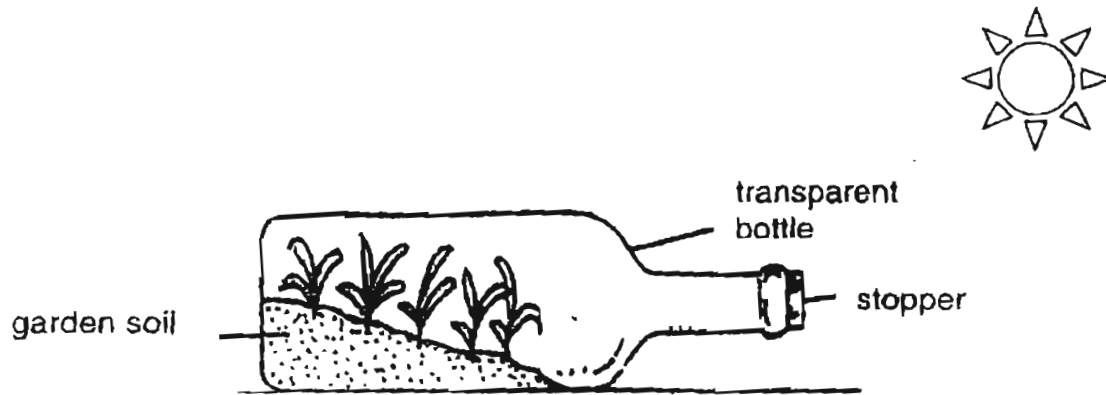

Which of the following processes are taking place in the bottle?

- A: The plant is carrying out respiration all the time.
- B: A continuous water cycle can take place in the bottle.
- C: The plant can carry out photosynthesis to make food in the presence of light.

- (1) A and B only
- (2) A and C only
- (3) B and C only
- (4) A, B and C

28. Davidson designed a wound-up robot as shown below.



He carried out his experiment following the steps below :

- i) He wound up the robot a few times.
- ii) He released the robot on the ground.
- iii) He measured the distance travelled by the robot.
- iv) He increased the number of winds and repeated steps (ii) to (iv).

What could be the possible aim/s of his experiment?

- A. To find out whether the number of winds would affect the distance travelled by the robot.
- B. To find out whether the amount of potential energy can affect the distance travelled.
- C. To find out whether the distance travelled will affect the number of winds.
- D. To find out whether the distance travelled will affect the amount of potential energy stored.

- |                     |                     |
|---------------------|---------------------|
| (1) A only          | (2) A and B only    |
| (3) B, C and D only | (4) A, C and D only |

29. Muthu set the apparatus below to prove one of the properties of light. He was able to see the candle flame.

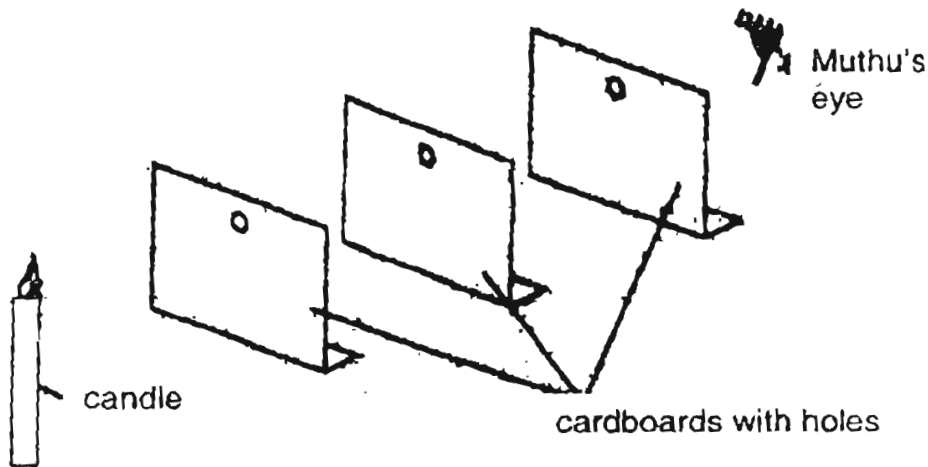

Which one of the following properties of light can be proved by the above experiment?

- (1) Light can be reflected.
  - (2) Light can travel in all directions.
  - (3) Light can travel in straight lines.
  - (4) Light can pass through transparent materials.
30. The diagram below shows a torch shone on a square piece of clear glass and a ball.

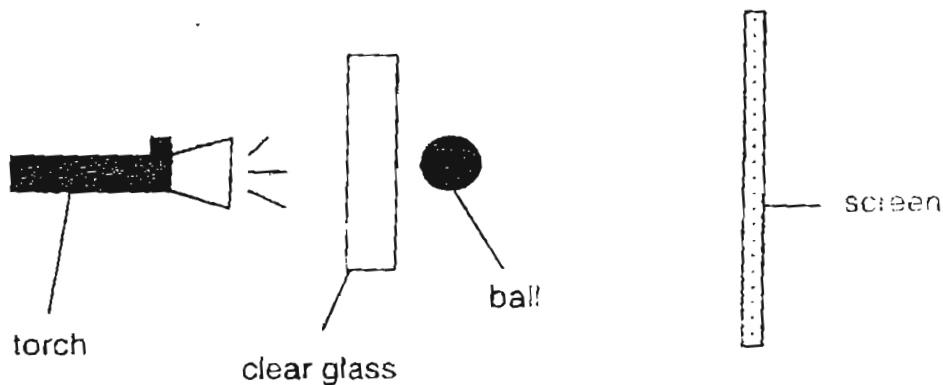

A shadow was cast on the screen.  
What could be done to enlarge the shadow?

- (1) Remove the clear glass.
- (2) Move the ball nearer to the screen.
- (3) Move the ball nearer to the clear glass.
- (4) Move the torch away from the clear glass.



Rosyth School  
Preliminary Examinations for 2005  
**SCIENCE**  
Primary 6 (EM1/2)

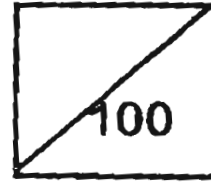

Total  
Marks:

Name: \_\_\_\_\_

Class: Pr 6 \_\_\_\_\_ Register No. \_\_\_\_\_ Duration: 1 h 45 mins

Date: 25.8.05 Parent's Signature: \_\_\_\_\_

---

## Booklet B

### Instructions to Pupils:

1. For questions 31 to 46, give your answers in the spaces given in this Booklet B.

\* This booklet consists of 16 pages . (Pg. 19 to 34)

This paper is not to be reproduced in part or whole without the permission of the Principal.

**PART II (40 marks)**

Write your answers for questions 31 to 46 in the spaces provided.

31. Sandy is carrying a pail of water from the toilet to her classroom so that she could use the water to wipe the classroom windows.

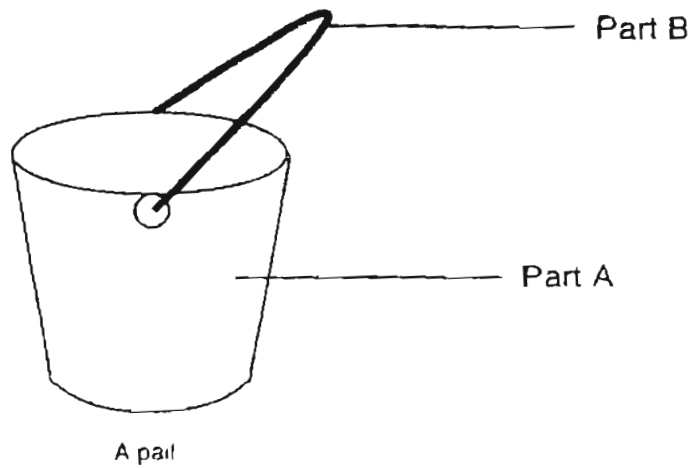

Explain why Part A of the pail is usually made of plastic and Part B is usually made of metal. (2m)

---

---

---

---

32. The diagram below shows the life cycle of a mosquito and a cat.

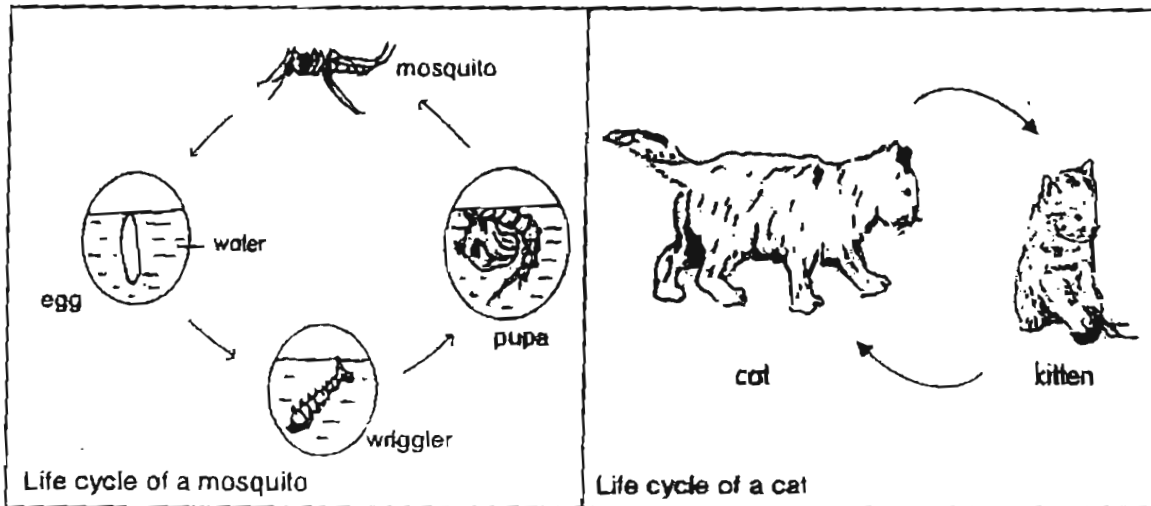

Sandy studied the 2 life cycles above and concluded that a mosquito develops from an egg while a cat does not develop from an egg.

(a) Is Sandy's conclusion correct? Explain your answer. (1m)

---



---



---

(b) State a difference between the life cycle of a mosquito and the life cycle of a cat? (1m)

---



---

33. Peter used a microscope to look at a specimen and the diagram below shows what he saw.

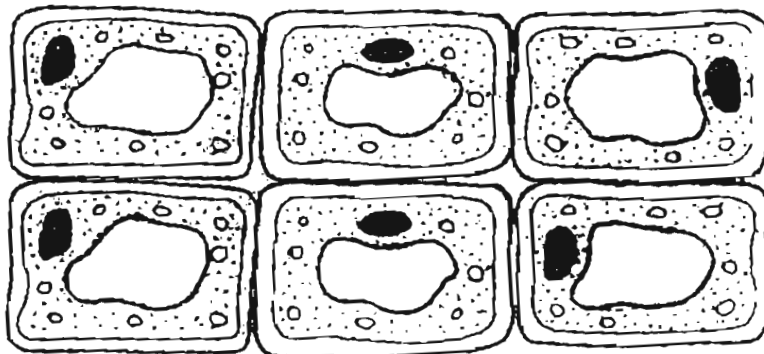

- (a) Is the specimen taken from a plant or an animal? (1m)

\_\_\_\_\_

- (b) Give 2 reasons for your answer in (a). (1m)

\_\_\_\_\_  
\_\_\_\_\_  
\_\_\_\_\_  
\_\_\_\_\_

34. Michael has 2 papaya trees in his garden, Tree E and Tree F.

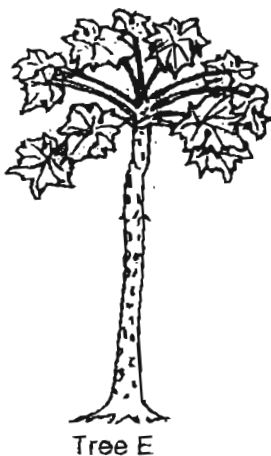

He made two observations about them.

Observation 1: Tree E and Tree F each bears only one kind of flower but the flowers they bear look different.

Observation 2: Only Tree F bears fruits. Tree E does not bear fruits.

(a) What do the above observations tell you about the flowers of both Tree E and Tree F? (1m)

---

---

---

(b) In order to bear fruits, what does Tree F need from Tree E? (1m)

---



35. Three sieves with different sized holes were arranged in a tall box as shown.

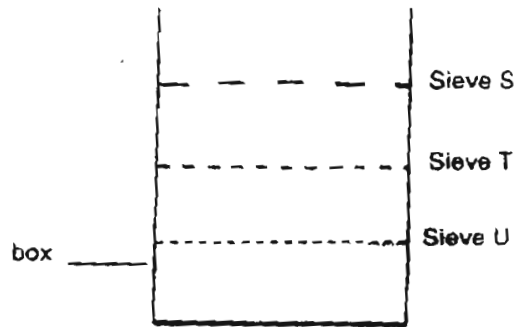

Some rocks were poured onto the top sieve and then shaken. This sorted the rocks according to size as in the diagram below.

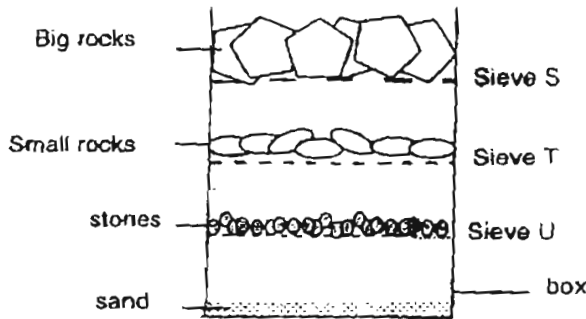

The order of the sieves was then changed as shown below.

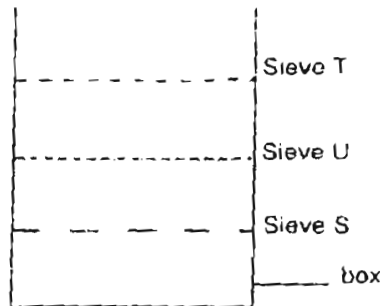

The same rocks were poured onto this new sieve arrangement and shaken. Draw and label in the diagram below how the rocks would be sorted. (2m)

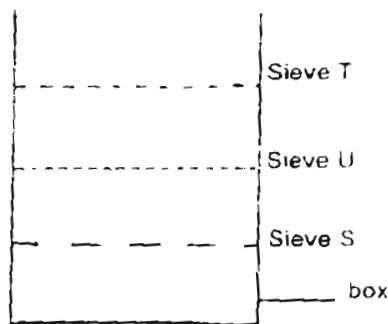

36. The diagram below shows the moon at two different positions from the Earth, Positions A and B.

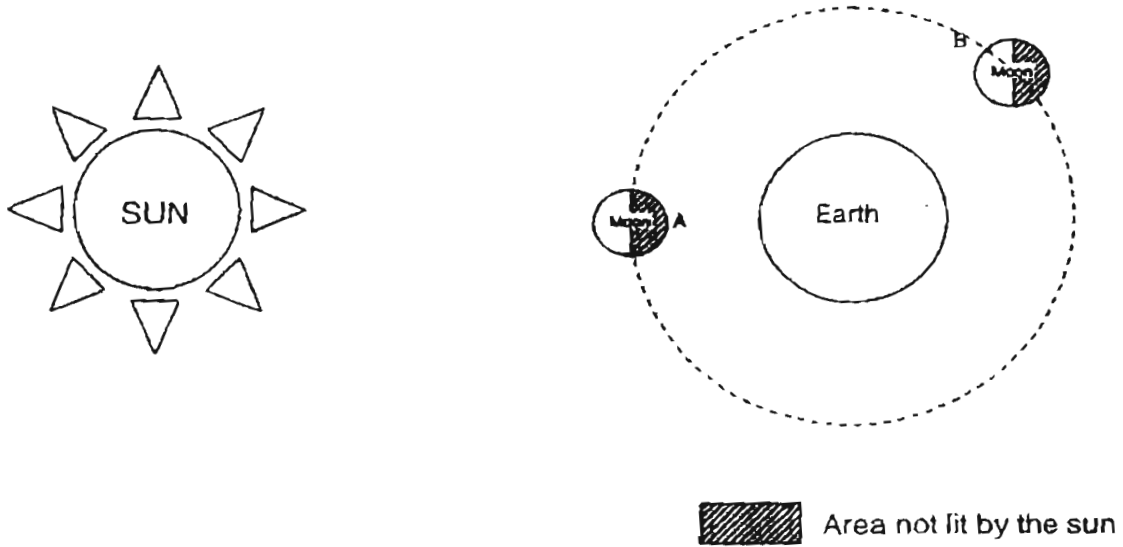

- (a) We cannot see a moon in the sky when the moon is at Position A. Explain why. (1m)

---



---



---

- (b) In the box below, draw the phase of the moon when it is at Position B. The outline of a full moon has been drawn for you. (1m)

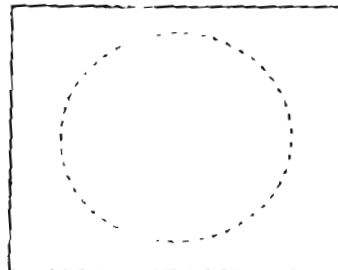

37. The diagram shows a new plant growing from a leaf.

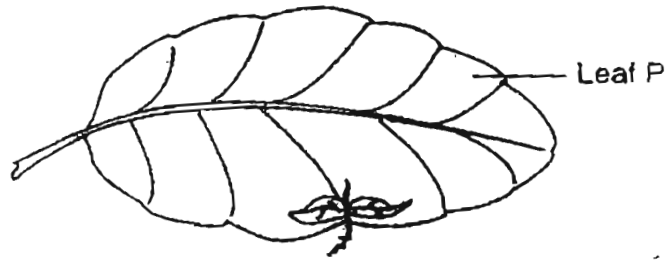

- (a) Label the new shoot and the new root in the diagram. (1m)
- (b) Leaf P is thick and fleshy. Why? (1m)

---



---

38. Study the table below. It shows the average pulse rate of a human being as he gets older.

Age (years)	Average pulse rate (beats per minute)
1	120
3	95
8	85
15	80
25	75
55	70
65	65

- (a) What can you conclude about the relationship between age and pulse rate? (1m)
- (b) When would a healthy 8-year-old boy have a pulse rate more than his usual average pulse rate? (1m)
- (c) Explain your answer in (b). (1m)

---



---



---



---

39. (a) Using symbols, draw a circuit diagram in the box provided below such that : (i) there are 3 bulbs connected in parallel and (ii) there are 3 batteries connected in series. (2m)

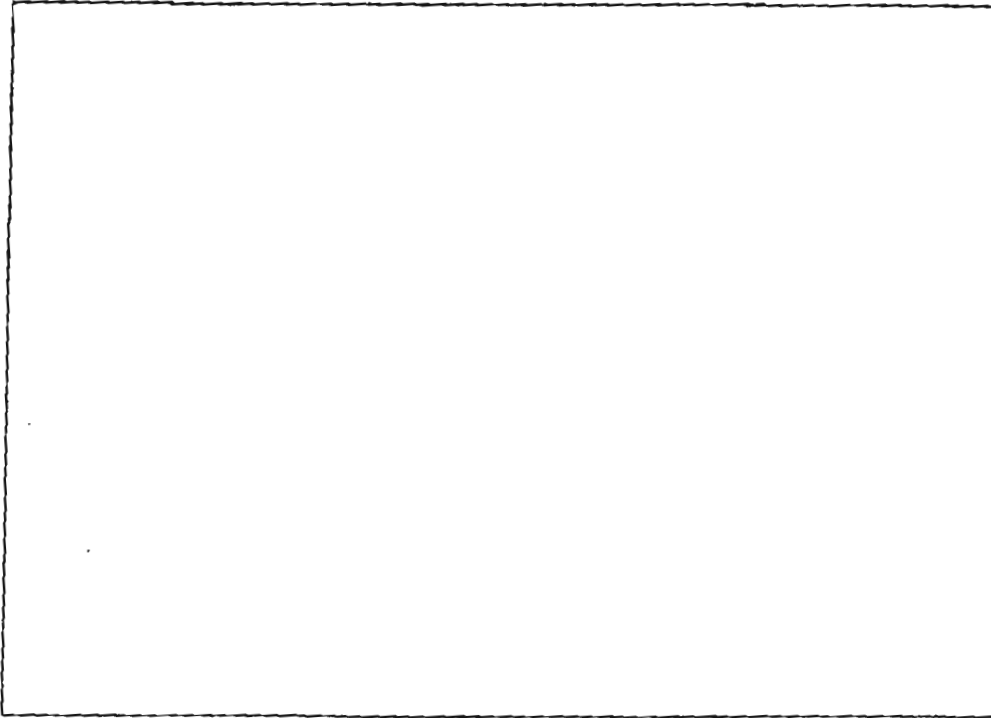

- (b) This circuit arrangement is usually preferred when connecting our lamps and electrical appliances in our homes. Give one reason for this preference. (1m)

---

---

---

40. Study the food web below. It shows a food web in a field and meadow.

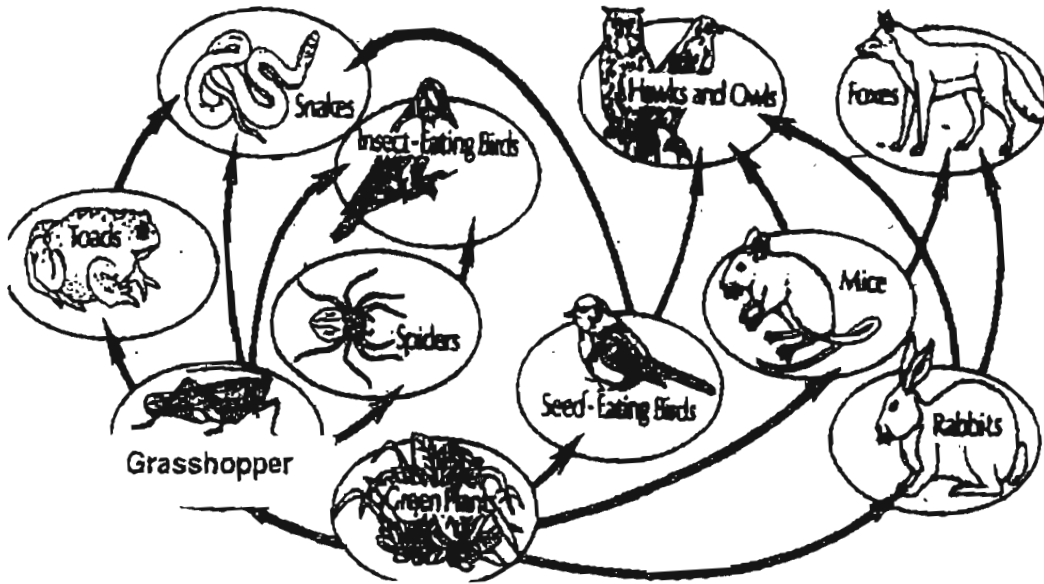

(a) Write down a food chain from the above food web involving four organisms. (1m)

---



---

(b) Devi observed that the number of rabbits increased initially and then decreased eventually when there were no foxes. Explain the reason for the changes in the population. (2m)

Increase :

---



---

Decrease:

---



---

(c) Grasshoppers have many predators. State two adaptations that a grasshopper has to protect itself against its predators. (2m)

---



---

41. Arul is a farmer. He found that his crops were affected by a certain pest and he started to spray pesticides to protect his crops.

(a) Give a reason why spraying pesticide is not a good solution. (1m)

---

---

(b) How could the farmer's problem be solved using biotechnological method? (1m)

---

---

42. Mary conducted an experiment to find out whether a ping-pong ball that has less mass than a golf ball will move a greater distance with the same amount of force applied.

She placed a metre ruler as shown below. Each ball was placed the same distance from the centre. She moved the metre ruler quickly forward with both hands.

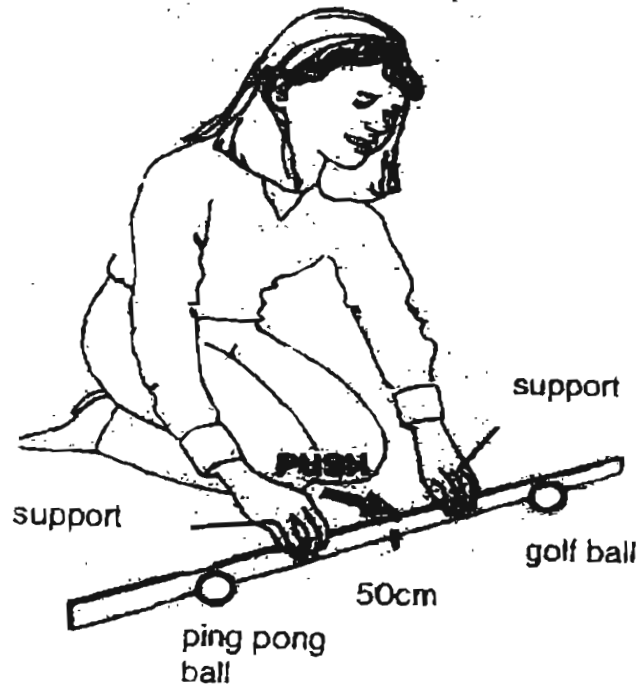

She measured the distance travelled by the two balls and recorded them in the table below.

Balls	Distance travelled ( cm )
Ping Pong	45
Golf	30

- (a) What is the relationship between the mass of a ball and the distance travelled? (1m)
- \_\_\_\_\_
- \_\_\_\_\_
- (b) What could Mary do to check whether her results are reliable? (1m)
- \_\_\_\_\_
- \_\_\_\_\_

43. A gardener wanted to use a plank to move some bricks in a wheelbarrow from point X to Y.

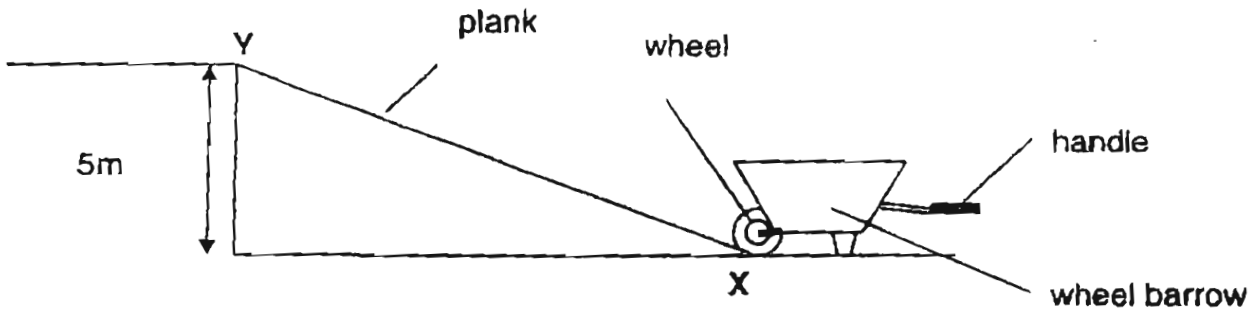

- (a) The gardener wants to use less force to lift up the load in the wheel barrow .  
At which side (near the handle or the wheel) should the gardener place the bricks? (1m)

---

- (b) Explain your choice in (a). (1m)

---



---



---



---



44. Aziz measured the distance moved by a load and the effort used to move the load in a simple pulley system. He used the results to plot a graph as shown below.

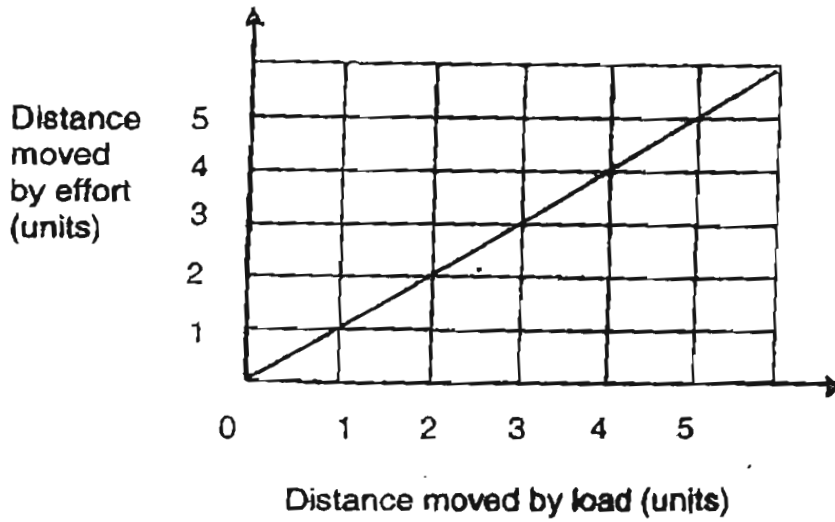

Refer to the two simple pulley systems G and H.

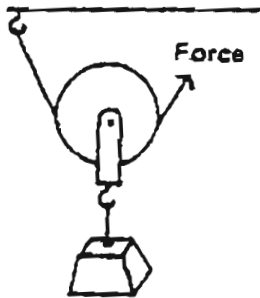

Pulley System G

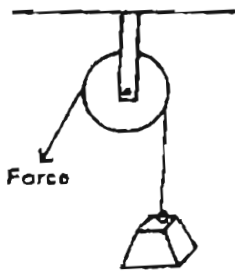

Pulley System H

- (a) Which one of the pulley systems (G or H) did he use to obtain the above result? (1m)

(Question 44 continues on the next page)

Later, Aziz decided to combine the two pulley systems G and H as shown below to raise the load.

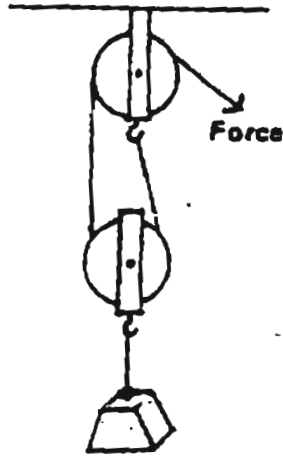

- (b) Give two advantages of using the combined pulley system to lift the load? (2m)

Advantage 1:

---

---

Advantage 2:

---

---

45. Study the comic strip below.



(a) What did Alex do to remove the bottle cap easily? (1m)

---



---

(b) How does the method stated in (a) help to remove the bottle cap? (1m)

---



---

You have two cups stacked together as shown below. The cup inside is made of metal and the cup outside is made of plastic. It was difficult to pull the 2 cups apart.

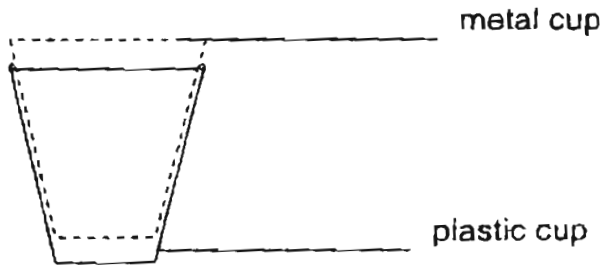

(c) How would you separate the two cups? (1m)

---



---

46. The picture below shows two classrooms as if you were looking down at them. Betty is seated in one classroom and Lisa is seated in the other classroom facing the corridor. They are not able to see each other while seated at their desks.

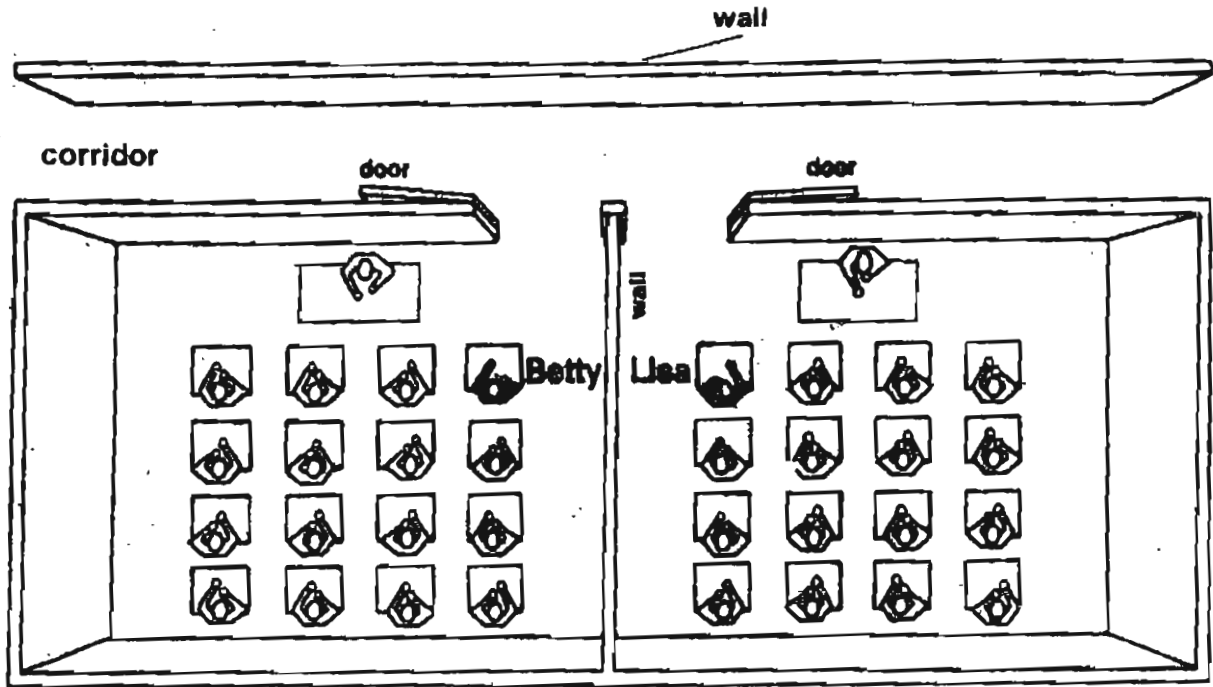

- (a) Where would you place a mirror to enable Betty and Lisa to see each other while seated at their desks?  
 Draw your labelled mirror in the picture above. (1m)

- (b) Explain how it works? (2m)

---



---



---



---

End of the Paper

SIA2

**PRIMARY 6 SCIENCE**  
**PRELIMINARY EXAMINATION 2005**

Names of setters: Mrs Theresa Teo and Mdm Parvathy  
Preliminary Assessment (2005)  
Science  
Pri. Six (EM1 and 2)

**Section A (60 marks)**  
Each question carries 2 marks.

Question No.	Answer
1	3
2	2
3	3
4	2
5	3
6	4
7	2
8	1
9	3
10	4
11	4
12	3
13	3
14	4
15	2

Question No.	Answer
16	3
17	1
18	4
19	4
20	4
21	1
22	2
23	2
24	3
25	2
26	3
27	4
28	2
29	3
30	3

**Section B (40 marks)**

1. Each question carries 2 to 4 marks.
2. Award full mark for a question or part of a question when the idea/concept and the key word(s) (if any) is (are) spelt correctly.

No marks if the answer contains key word(s) but expresses a wrong idea/concept.

3. ½ mark is deducted for wrong spelling of key word. Maximum deducted for a question is ½ mark (regardless of the number of parts to the question).

Circle the key word which has ½ mark deducted from it.

4. Do not deduct any mark for an answer that has grammatical errors provided idea/concept is clear or has poor expression.
5. If more than one answer, mark only the answer if the other answer is not wrong.

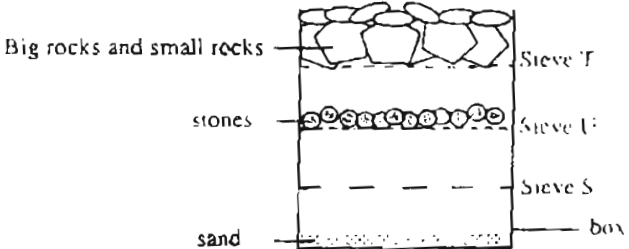
Qn No.	Correct/Acceptable Answer	Marks Awarded
31b	Part A needs to <u>hold water</u> so it has to be <u>waterproof</u> (½ m) and plastic is <u>waterproof</u> . (½ m) Part B cannot break easily and must <u>withstand the weight of the water</u> in the pail so <u>it must be strong</u> (½ m) and metal is <u>strong</u> . (Accept any reasonable answer.)	1m each
32a	No. A cat also develops from an egg but <u>inside the mother's body</u> (½ m) and the egg is not laid. (½ m)/ The <u>cat gives birth to its young alive</u> . (½ m)	1m
32b	(Any of the following answers.) The mosquito has 4 stages in its life cycle but the cat has 2. The young of a mosquito lives in water but the young of a cat lives on land. The young of a mosquito does not look like the parent but the young of a cat looks like the parent.	1m
33a	The specimen is taken from a plant.	1m
33b	The cells in the specimen have a cell wall and chloroplasts (½ m) and <u>only plant cells have cell walls and chloroplasts</u> (½ m). (If student mention that the cells in the specimen have one very large vacuoles and plant cells have few large vacuoles but animal cells have numerous small vacuoles. Can accept for (½ m)	1m
34a	Tree Y bears flowers that have only female parts (½ m) while Tree X bears flowers that have only male parts (½ m). / The observations tell us that the flowers of Tree X and Tree Y are unisexual (½ m) and the flowers of Tree Y are female. (½ m)	1m
34b	Pollen grains	1m
35	 <p>Each correct position 1/4 mark but minimum ½ mark so must get</p>	2m

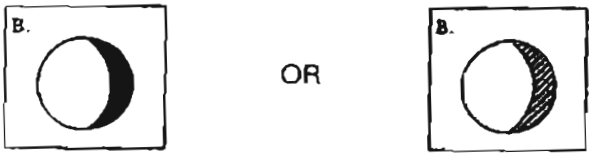
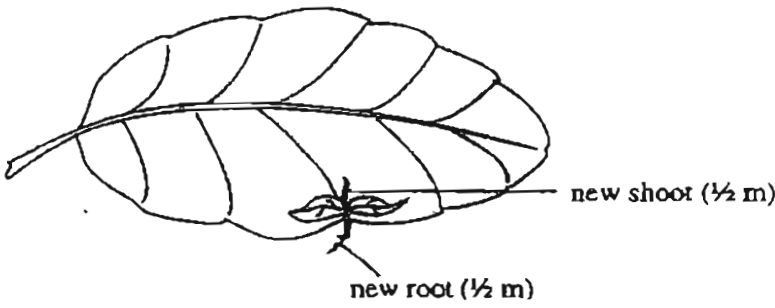
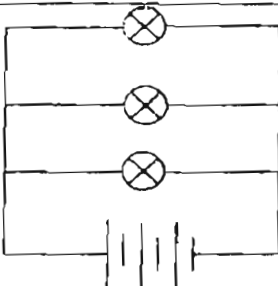
	minimum two positions correct.	
36a	The half of the moon <u>not lit by the sun is facing the Earth</u> . The area of the moon <u>not lit by the sun is completely facing the Earth</u> .	1m
36b	At position B, the moon is a left gibbous or waning gibbous. 	1m
37a		
37b	<u>They have a store of food for the new plant</u> (which the new plant needs until it can make its own food).	1m
38a	As age increases/as a person gets older, his pulse rate decreases.	1m or no marks
38b	<u>When he exercises</u> , his pulse rate would be more than his usual average. (accept any reasonable answer.)	1m
38c	When the boy exercises, he <u>needs more energy</u> ( $\frac{1}{2}$ m) so his <u>heart beats faster</u> to pump more blood to the cells ( $\frac{1}{2}$ m) hence his pulse rate increases.	1m
39a	 <p>Award 1m if bulbs are drawn in parallel. Award 1m if batteries are drawn in series. Minus 1/2m for incorrect wiring or incorrect drawing of symbol etc.</p>	2m

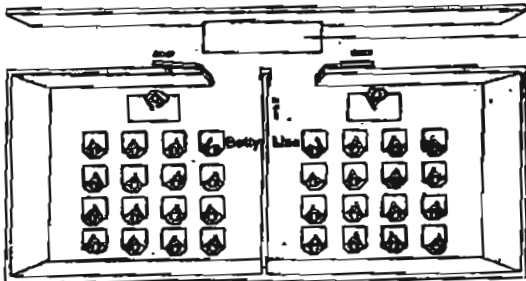

39b	When one lamp or electrical appliance does not work, the rest of the lamps or electrical appliances will not be affected. OR Switches can be connected in series to each lamp or electrical appliance without affecting the other components. OR This allows for equal brightness for all the lamps.	1m
40a	(Green ) Plants → grasshoppers → spiders → insect-eating birds(1m) Or (Green ) Plants → grasshoppers → toads → snakes (1m) No marks awarded if no arrows.	1m
40b	There is <u>less predators</u> (1/2m) for the rabbits, so <u>death rate decreases / less is killed.</u> (1/2m) Do not award (1/2m) if no predators for rabbits. ----- Increase in rabbits lead to <u>shortage/decrease/less of food /plants</u> (1/2m) so <u>death rate increases / more dies.</u> (1/2m)	1m 1m
40c	It has <u>strong hind legs to jump away.</u> (1m) It has <u>wings to fly away.</u> (1m) It is <u>green to blend with the environment/ to camouflage.</u> (1m)	2m
41a	It can cause air/water/land <u>pollution.</u> (1m) Or The pesticide can be <u>accumulated in the crop</u> (1/2m)and <u>affect its quality .or poison the consumer.</u> (1/2m)	1m
41b	Plants can be <u>genetically modified</u> .(1/2m)to be <u>resistant to that pest.</u> (1/2m)	1m
42a	The less the mass of a ball , the greater the distance travelled/moved (1m) or vice versa. Do not award mark if the order of the variables is reversed. No half mark.	1m
42b	She should <u>repeat the experiment</u> to ensure the answers are reliable. (1m)	
43a	Near the wheel end (1m)	1m
43b	The <u>load is further from the effort</u> (1/2m) , the <u>force will be less/reduced.</u> (1/2m) or The <u>load is nearer to the fulcrum /wheel</u> (1/2m) , the <u>force /effort</u>	1m

	<u>needed will be reduced.(1/2m)</u>	
44a	<u>6 (1m)</u>	1m
44b	It can <u>reduce the effort (1m)</u> needed to lift the load and <u>change the direction of force.(1m)</u>	2m
45a	He placed the <u>bottle cap (1/2m)</u> under <u>hot running water.(1/2m)</u>	1m
45b	The bottle cap <u>gained heat (1/2m)</u> from the hot water and it <u>expanded(1/2m)</u> .	1m
45c	Pour <u>cold water/put ice cubes into the metal cup/ inside cup(1m)</u> or <u>Put the two cups in a freezer for some time. (1m)</u>	1m
46a	 <p style="text-align: right;">mirror (1/2m)</p> <p>The mirror in the centre between the 2 classrooms (1/2m)</p>	1m
46b	<u>Light travels from Betty to the mirror.(1m)</u> Then the <u>light is reflected (1/2m)</u> by the mirror <u>to Lisa's eyes.(1/2m)</u> The answer can be the other way , start from Lisa and go to Betty's eyes.	2m

— 7/6 END —  
62