

SIA 2

Index No :

--	--	--	--	--	--	--	--	--



**CATHOLIC HIGH SCHOOL
- PRIMARY SIX
PRELIMINARY EXAMINATION, 2005**

**SCIENCE
EM 1 / EM 2**

Name: _____ ()

Class : Primary 6 _____

Date : 25 Aug 2005

BOOKLET A

30 Questions
60 Marks

Total Time for Booklets A & B : 1 hour 45 minutes

Instructions to Candidates

Do not open this booklet until you are told to do so.
Follow all instructions carefully.
Answer all questions.

Section A: Multiple Choice Questions (60 Marks)

For each question from 1 to 30, four options are given. One of them is the most suitable answer. Make your choice (1, 2, 3 or 4). **Shade the correct oval (1, 2, 3 or 4) on the Optical Answer Sheet.**

1. Sally found a living organism which she thinks is an insect. In order to confirm that it is an insect, what should she be looking for?

- A a pair of wings
- B three pairs of legs
- C multi-segmented body parts

- (1) B only (1)
- (2) A and C only
- (3) B and C only
- (4) A, B and C only

2. Cacti have many adaptations that help them survive in a desert.

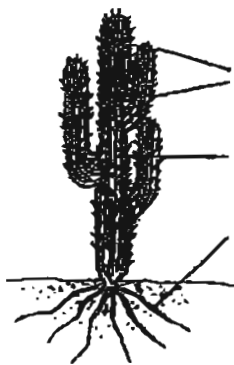

A: needle-like leaves

B: fleshy stem

C: roots widely spread out.

Which of the labelled part(s) of the cactus help(s) it reduce water loss to its surroundings?

- (1) A only
- (2) B only
- (3) A and B only (1)
- (4) A, B and C

3. The diagrams below are not drawn to scale. Study them carefully before answering the question.

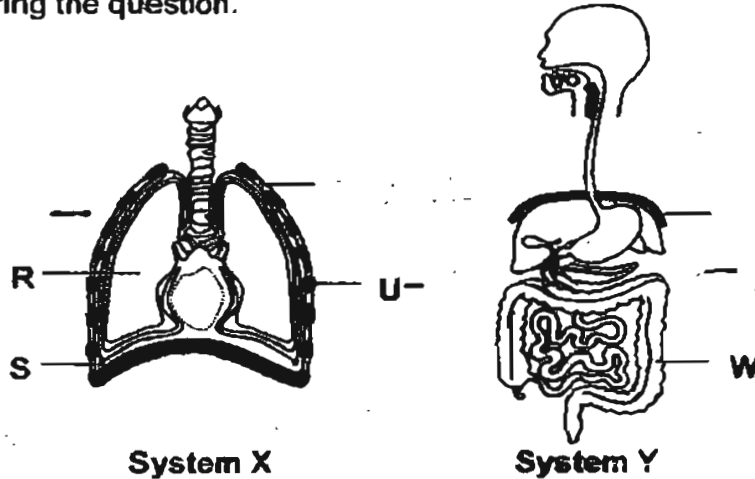

Choose the correct statements about systems X and Y from the following.

- A S separate system X from system Y.
 - B If T is a muscle, then U must be a bone.
 - C W is a muscle as it can contract and relax.
 - D S in system X is the same as V in system Y.
 - E R is a muscle that is why it can contract during breathing.
- (1) A, B and E only
 (2) B, C and D only
 (3) A, C, D and E only
 (4) A, B, C and D only
4. Which of the following is a non-flowering plant which reproduces by seeds?
- (1) fern
 - (2) pine
 - (3) mould
 - (4) hibiscus

5. The diagrams below show the change in a part found on leaves.

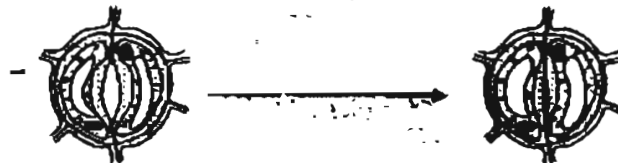

Which one of the following statements is true about the change above?

- (1) It happens only when plants breathe.
- (2) It happens only in plants found in deserts.
- (3) It does not happen at all in floating aquatic plants.
- (4) It helps to reduce the amount of water loss in plants.

6. Refer to the diagram below.

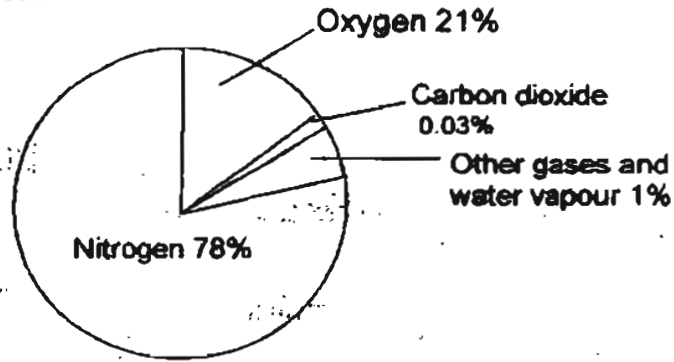

We breathe in air with the above composition. Which one of the following shows the composition of air that has been breathed out?

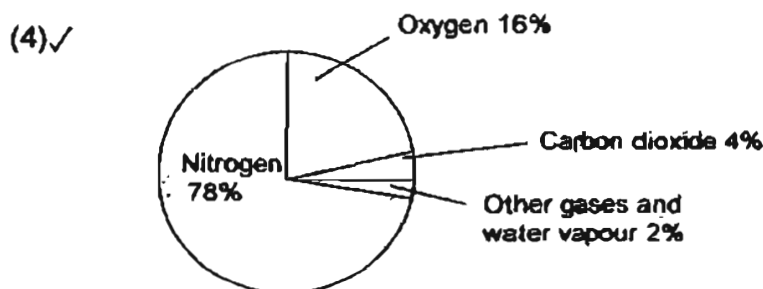
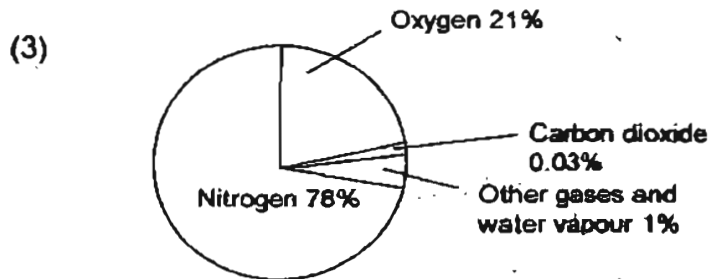
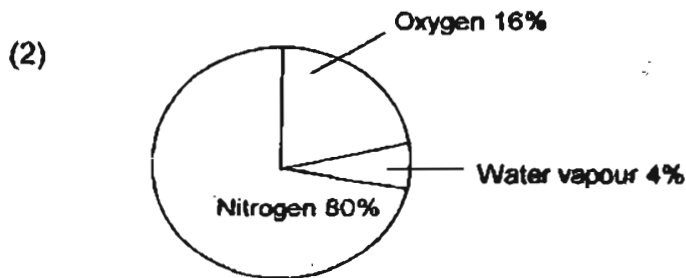
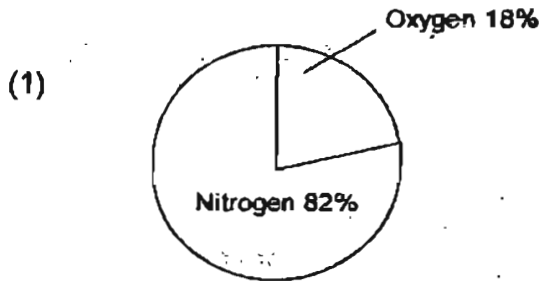

Zainal set up an experiment as follows.

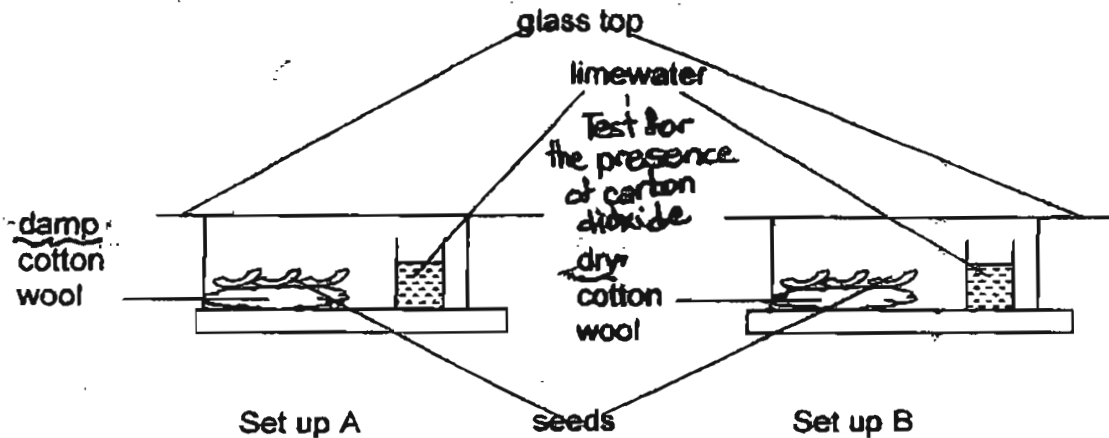

After a day, the limewater in Set up A turned chalky but not in Set up B. What was Zainal trying to find out?

- (1) To find out whether seeds need air for germination.
- (2) To find out whether photosynthesis had taken place during germination.
- (3) To find out whether carbon dioxide was given out during respiration when the seed was germinating.
- (4) To find out whether carbon dioxide was given out during photosynthesis when the seed was germinating.

8. Biotechnology is helpful to us by producing _____.

- A a larger crop yield
- B food by fermentation
- C disease-resistant plants
- D plants that can withstand drought

- (1) A and B only
- (2) C and D only
- (3) A, B and D only
- (4) A, B, C and D

9. Anthony wanted to conduct an experiment to show the importance of carbon dioxide in photosynthesis. He followed his teacher's instructions in setting up an experiment as shown in the diagram below.

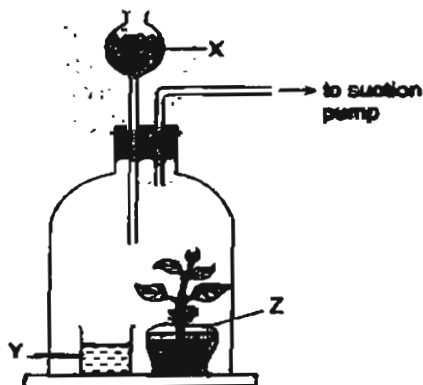

Based on the experiment that Anthony conducted, what is the most likely function of the parts labelled, 'X', 'Y' and 'Z' in the set up?

- (1) To remove all oxygen from the set up.
 - (2) To remove all carbon dioxide from the set up.
 - (3) To supply unlimited amount of oxygen for the plant.
 - (4) To supply limited amount of carbon dioxide for the plant.
10. Which one of the following animals has the life cycle as shown below?

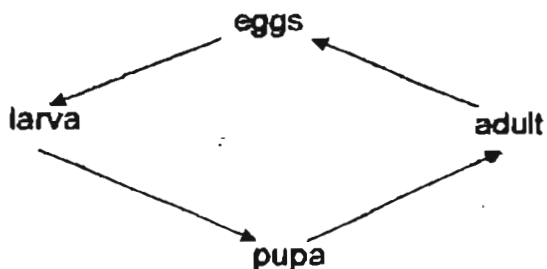

- (1) Dragonfly
- (2) Cockroach
- (3) Grasshopper
- (4) Mealworm Beetle

11. Wendy wanted to demonstrate the main difference between a plant cell and an animal cell. She filled a plastic bag with water and then placed it into the box as shown below.

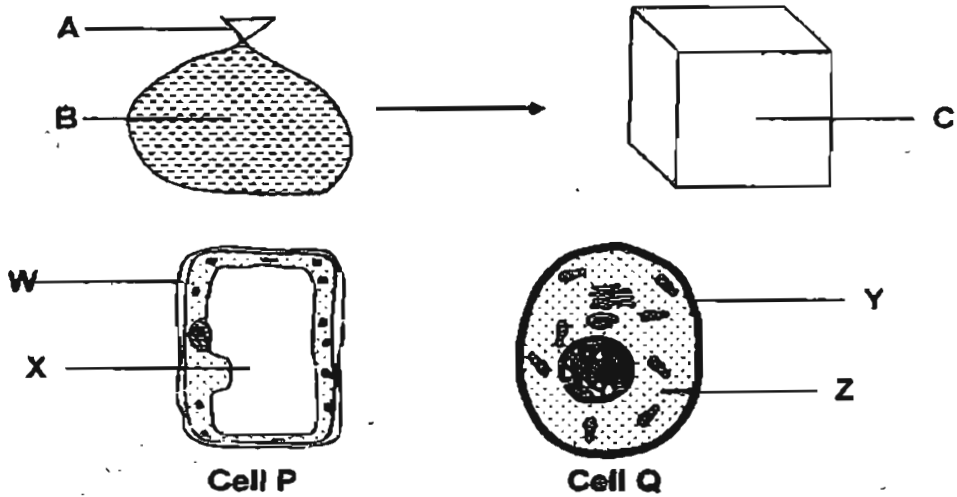

Which one of the following has been correctly matched?

- (1) W is represented by A, X is represented by B and Y is represented by C
- (2) Y is represented by A, Z is represented by B and X is represented by C
- (3) W is represented by A, X is represented by B and Z is represented by C
- (4) Y is represented by A, Z is represented by B and W is represented by C

12. The table below shows the weather conditions and when sparrows and toucans were sighted at a park during a week.

Day	Weather Conditions				Sparrows sighted	Toucans sighted
	Hot	Cold	Windy	Calm		
Monday						
Tuesday						
Wednesday						
Thursday						
Friday						
Saturday						

Toucans are most likely to visit the park on a _____ day.

- (1) hot
- (2) cold
- (3) calm
- (4) windy

13. The following diagrams A to D show the stages of reproduction of an organism that is not in the correct sequence.

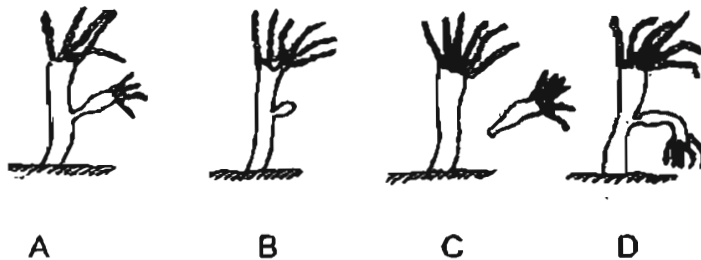

Which of the following sequence shows the correct order?

- (1) A → C → B → D
 (2) B → A → D → C ✓
 (3) C → D → B → A
 (4) D → B → A → C
14. 2 Shorea fruits P and Q were released from a height of 2 metres. The length of time the fruits stayed in the air was measured. Which is the likely correct timings of the 2 fruits?



	P	Q
(1)	2.8s	4.5s
(2)	4.5s	2.8s
(3)	4.5s	4.5s
(4)	2.8s	2.8s

15. The 2 graphs below show the relationship between organisms in a community.

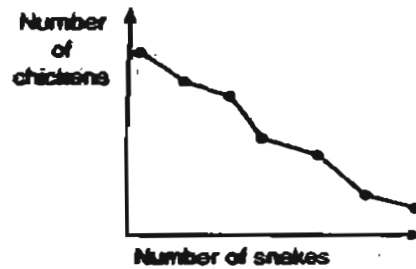
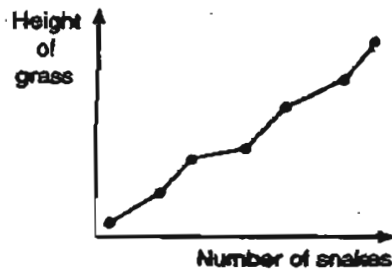

Which one of the following statements is most likely correct?

- (1) The number of chickens will decrease if the height of the grass decreases.
 - (2) The number of chickens will decrease if the number of snakes decreases.
 - (3) The number of snakes will increase if the height of the grass decreases.
 - (4) The number of chickens will increase if the height of grass decreases.
16. The diagrams below show container R filled with water to the brim and an empty container S.

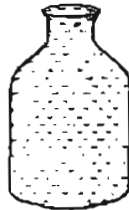

R



S

Which of the following statements correctly states what will happen if she pours all the water from container R into container S?

- A The shape of the water will change while the mass of the water will remain unchanged.
 - B The water level will change while the mass of the water will remain unchanged.
 - C The water level will change and the shape of the water will change.
 - D The shape of the water will change and the mass of the water will change.
- (1) A and B only
 - (2) C and D only
 - (3) A, B and C only
 - (4) B, C and D only

17. Hua Min wanted to find out which material A, B, C or D is the strongest. He used the following set-up for his investigation.

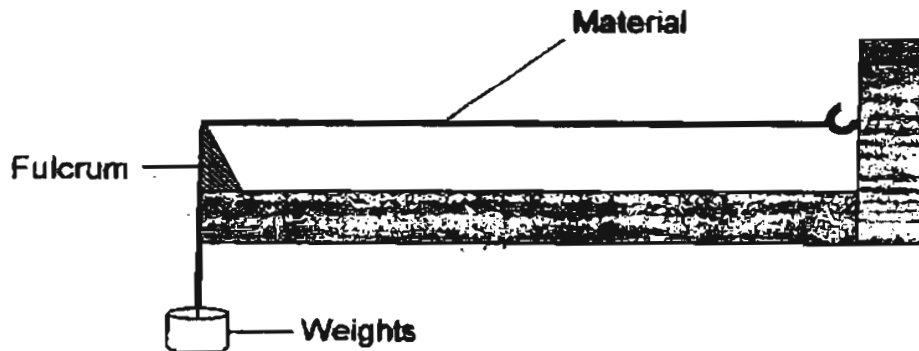

Weights were added to the suspended end of each material until it gave way. The thickness and length of each material were kept constant. The following results were obtained.

Material	A	B	C	D
Weights hung before the material breaks	580g	630g	350g	490g
Weight of material	37g	32g	45g	48g

Which one of the following shows the strength of the materials in ascending order?

- (1) B, A, C, D
- (2) C, D, A, B
- (3) C, D, B, A
- (4) D, C, A, B

18. Jacelyn set up an experiment as shown below to investigate the property of magnets. One at a time, she placed four items, each made of only one type of material, between a bar magnet and a paper clip.

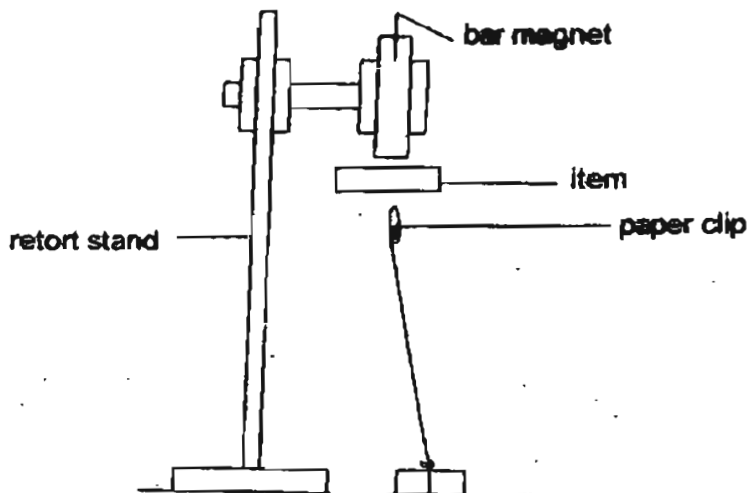

She recorded her observations in a table as shown below.

Materials that items were made of	Observations
W	Paper clip dropped from where it was.
X	Paper clip remained at where it was.
Y	Paper clip remained at where it was.
Z	Paper clip dropped from where it was.

Which of the following correctly describes the materials representing W, X, Y and Z respectively?

	W	X	Y	Z
(1)	aluminum	steel	copper	iron
(2)	copper	aluminum	iron	steel
(3)	steel	copper	aluminum	iron
(4)	iron	steel	copper	aluminum

19. Which one of the following graphs shows the length of a tree's shadow from 8 am to about 6 pm?

(1)

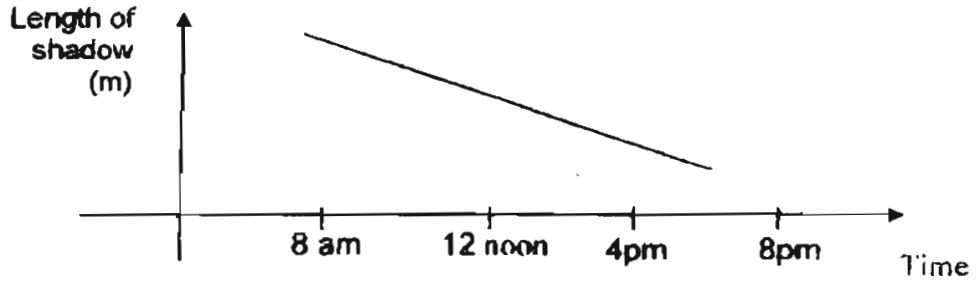

(2)

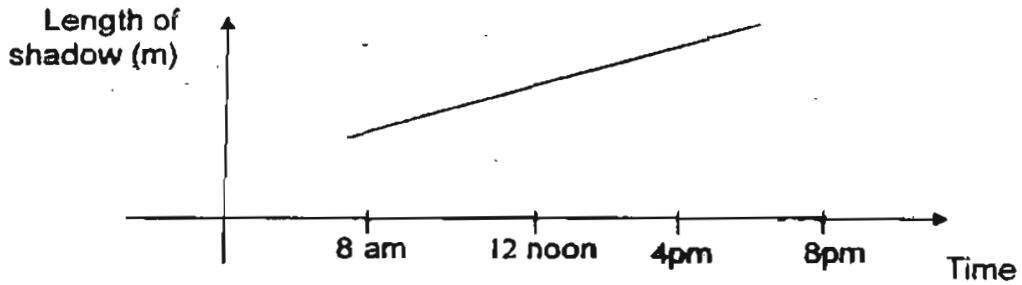

(3)

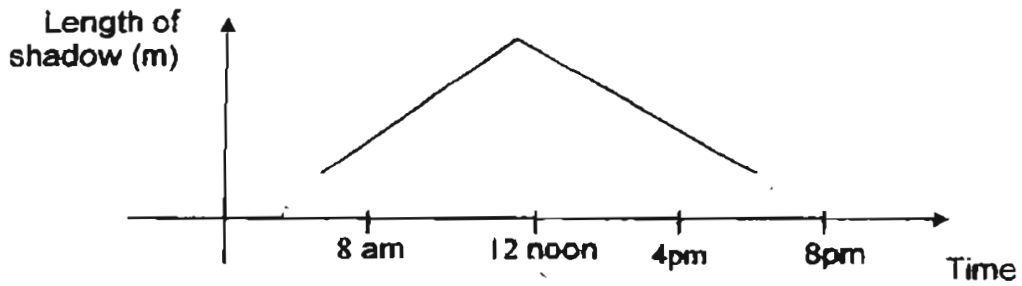

(4)

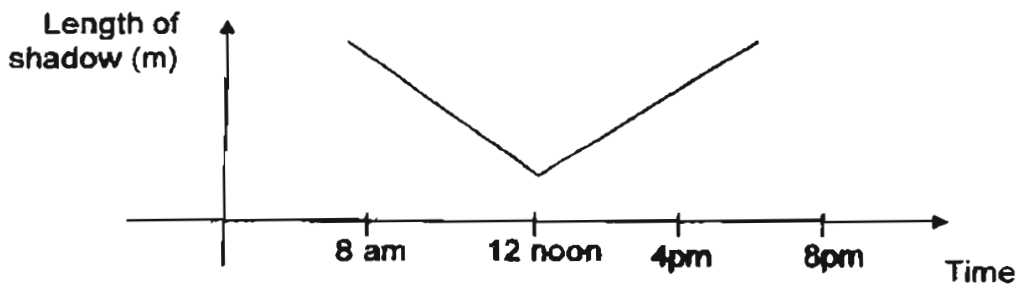

20. An experiment was set up to compare the rates of evaporation of 2 liquids X and Y. The diagrams below show 4 different set-ups A, B, C and D.

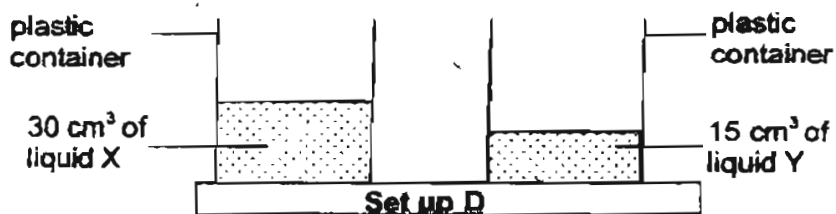
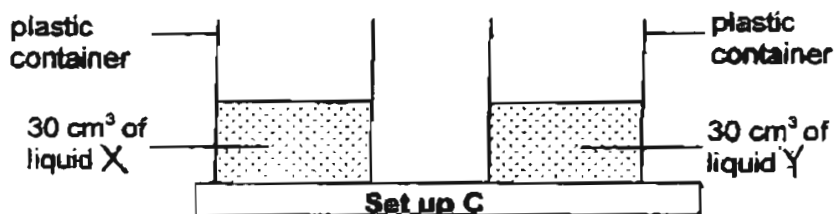
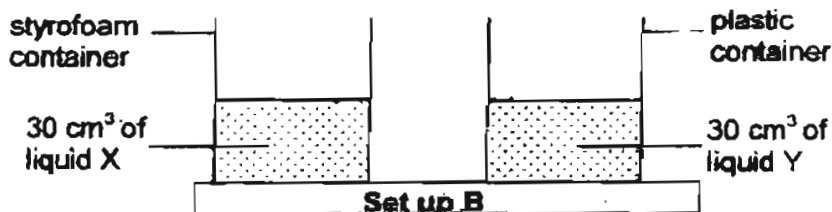
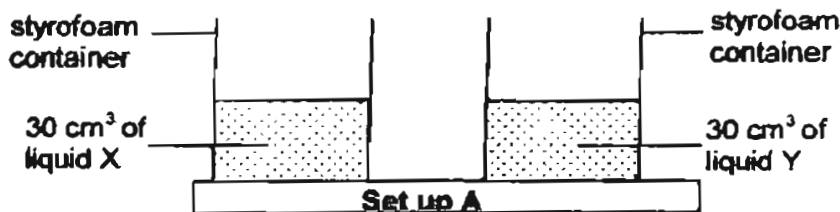

Which of the above set ups will not give a fair test?

- (1) A and B only
- (2) B and D only ✓
- (3) A, C and D only
- (4) B, C and D only

21. Azlina noticed that the diagram drawn below is wrong.

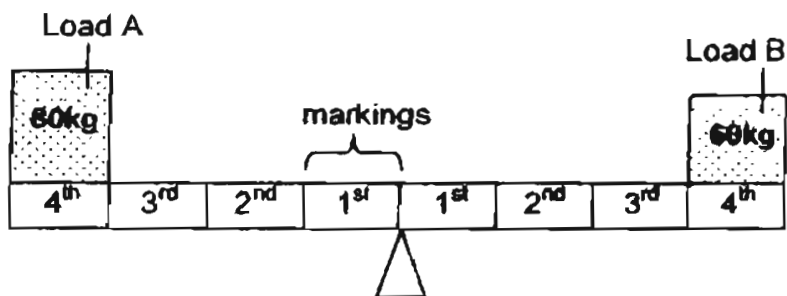

How should she correct the diagram above in order to balance both loads?

- (1) She should move Load A to the 1st marking.
 - (2) She should move Load A to the 3rd marking.
 - (3) She should move Load B to the 2nd marking.
 - (4) She should move Load B to the 3rd marking.
22. Which of the following statements about heat are correct?

- A Heat loss from a substance causes its temperature to decrease.
- B Heat has a definite volume but no definite shape.
- C Most heat sources also produce light.
- D The sun is our main source of heat

- (1) A, B and C
- (2) A, C and D
- (3) B, C and D
- (4) A, B, C and D

23. Ahmad set up an experiment as shown below.

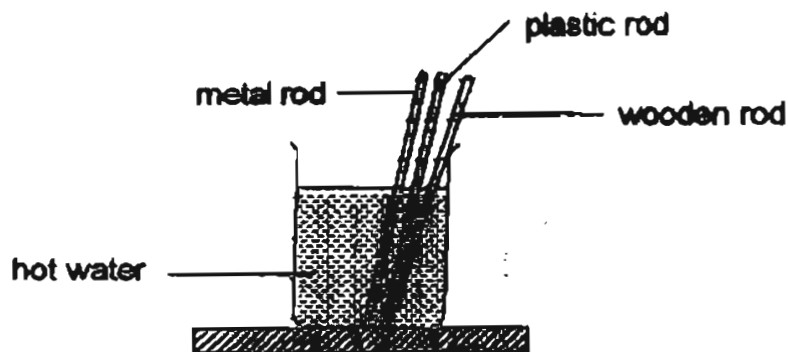

The metal, plastic and wooden rods were of equal thickness. Ahmad left them in the hot water for about one minute. Then he touched the ends of the rods. The results are recorded as follows.

Objects	Observation
Metal rod	Felt hot
Plastic rod	Felt warm
Wooden rod	Felt slightly warm

What was Ahmad trying to find out? He wanted to know _____.

- (1) which material cooled faster
- (2) which material became hot faster
- (3) which material conducted heat well
- (4) which material expanded when placed in hot water

24. Which one of the following is not a result of the Earth getting warmer?

- (1) The sea level would rise.
- (2) More trees would be cut down.
- (3) The ice around the North and South poles will melt.
- (4) Some plants and animals would not be able to adapt to the changes and become endangered.

25. The diagram below shows the sun, earth and moon in their relative positions not drawn to scale. The numbers next to the moon show the different phases of the moon.

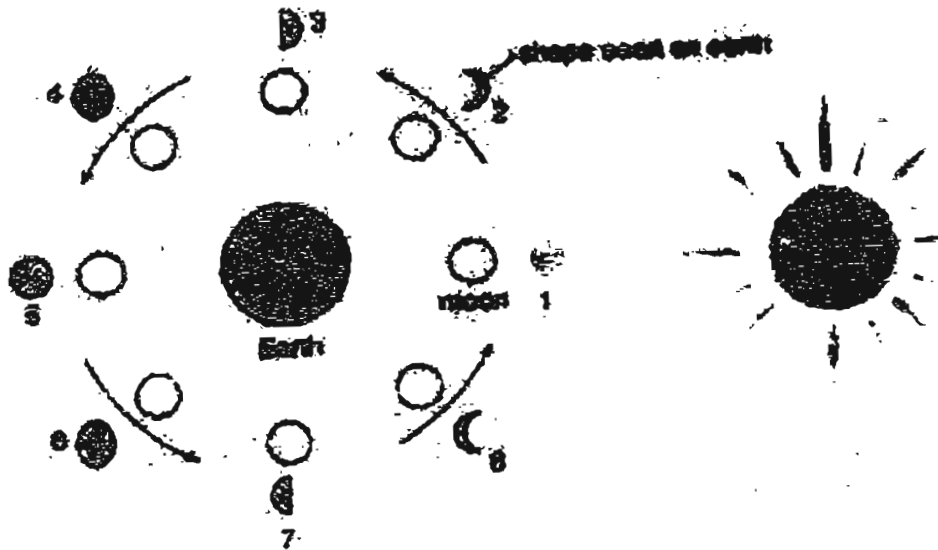

If Kenny observed the moon at phase 2 on the 3rd of June, he will see phase 6 on the _____ and _____ at phase 1.

- (1) 20th June, no moon
 - (2) 20th June, full moon
 - (3) 17th June, full moon
 - (4) 17th June, no moon.
26. Which one of the following activities best describes an interchange of energy between kinetic energy and gravitational potential energy only?
- (1) A swing in motion.
 - (2) Ringing of an electric door bell.
 - (3) Water boiling in an electric kettle.
 - (4) A piece of stone that is kept in a cupboard.

27. The diagram below shows a circuit card tested with a circuit tester.



Ravi used the circuit tester to test the clips. He recorded his observations in the table below.

Clips tested	Does the bulb of the circuit tester light up?
W and X	Yes
W and Y	Yes
W and Z	No
X and Y	Yes
X and Z	No
Y and Z	No

From the table, deduce which one of the following circuit cards was tested?

(1)

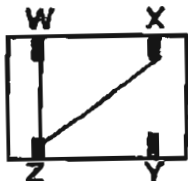

(2)

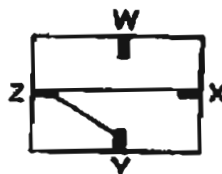

(3)

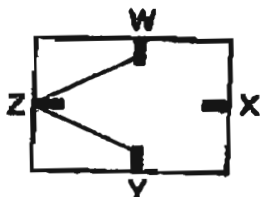

(4)

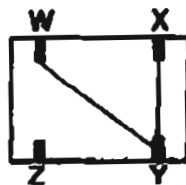

28. Look at the diagrams of the 2 objects below.

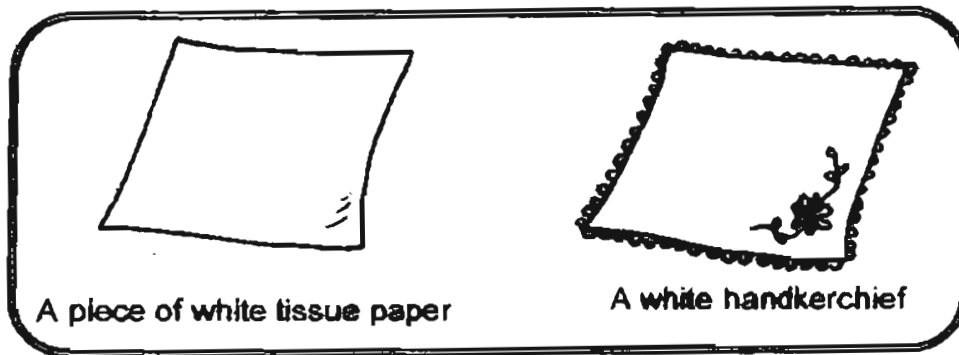

Based on your observation of the 2 objects above, how are they similar?

- (1) Both are of the same size.
- (2) Both are of the same flexibility.
- (3) Both are of the same thickness.
- (4) Both are used for the same purpose.

29. Mimi wanted to find out whether a bulb would glow more brightly if she increased the number of batteries in the circuit. Each time she arranged them in series and used only new batteries.

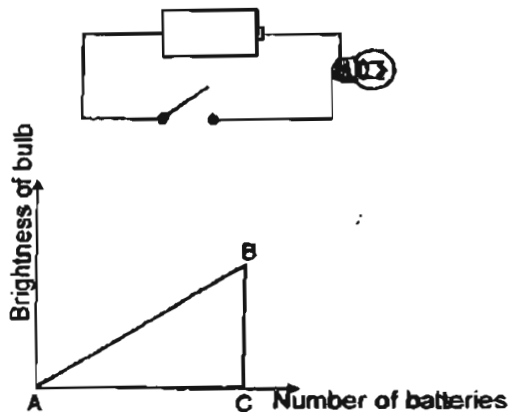

Based on the graph she had plotted, what does line BC show?

- (1) The bulb had fused.
- (2) The batteries had expired.
- (3) The copper wire had become too hot.
- (4) The bulb had reached maximum brightness.

30. Study the flowchart below that shows the conversion of light energy into two other forms of energy.

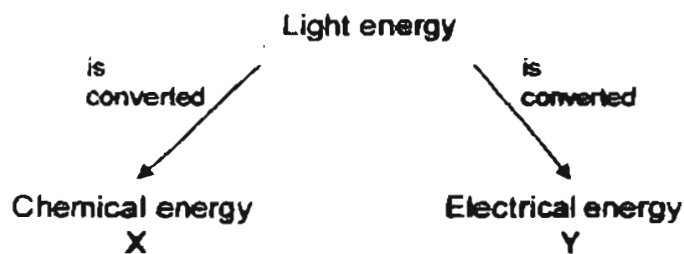

Which of the following examples given below correctly represents 'X' and 'Y'?

	X	Y
(1)	Steam engine	Fuels in car engines
(2)	Electric light bulb	Solar water heaters in homes
(3)	Launching of rockets	Loudspeaker in radios
(4)	Photosynthesis in green plants	Solar cells in calculators

Index No :

--	--	--	--	--	--	--	--	--	--



**CATHOLIC HIGH SCHOOL
PRIMARY SIX
PRELIMINARY EXAMINATION, 2005**

**SCIENCE
EM 1 / EM 2**

Name: _____ ()

Class : Primary 6 _____

Date : 25 Aug 2005

BOOKLET B

16 Questions
40 Marks

Total Time for Booklets A & B : 1 hour 45 minutes

Instructions to Candidates

Follow all instructions carefully.
Answer all questions.

Parent's Signature: _____

Date: _____

Score	
Section A	60
Section B	40
Total	100

80

SECTION B : Open-Ended Questions (40 Marks)

Read the following questions carefully and write your answers in the space provided. The maximum number of marks which can be awarded is shown in the brackets [] at the end of each question or part-question.

31. Study the information given below.

- The dragonfly nymph is both a predator and a prey.
- The tadpole feeds on water plants only.
- The water stick insect feeds on tadpoles and dragonfly nymphs only.
- The dragonfly nymph is a carnivore.

Based on the information given, construct a food web for the organisms above in the space below. [2]

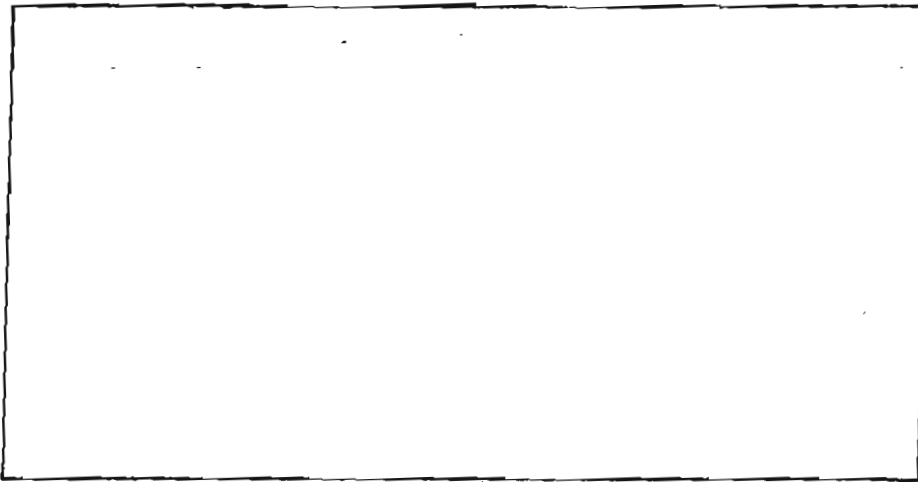

32a) The classification below shows how some of our skeletal system can be grouped. Fill in each blank with the correct word. [1]

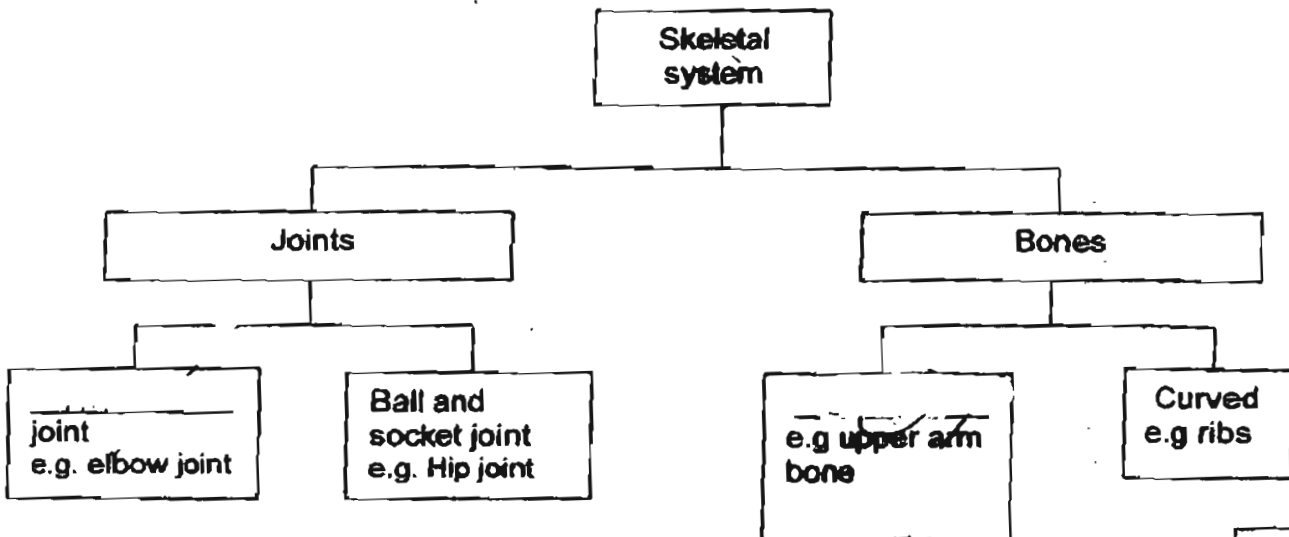





3

81

32b) Meng Hui wanted to find out whether exercising would affect his pulse rate. Tick the instrument below that he would need to conduct the experiment.

[½]

Instruments	Tick(✓)
 stopwatch	
 thermometer	
 beaker	
 weighing scale	

c) Meng Hui did the following steps in the experiment:

Step 1: Ran on the spot for about one minute.

Step 2: Counted his pulse rate immediately after running.

Step 3: Recorded the result.

Step 4: Continued to take and record his pulse rate at every one minute interval until it returned to normal.

i) His teacher said that he had left out one step in his experiment. State the step he had left out.

[½]

ii) Give a reason for your answer in (i).

[1]

33a) Name two essential conditions required for photosynthesis to take place, [1]

33b) Photosynthesis and respiration are closely related and are also important processes for the survival of all living things.

i) State one difference between both processes. [1]

ii) Explain why respiration is important for the survival of living organisms. [1]

34. A forest was destroyed by fire. Put a tick (✓) in the appropriate column in the table below to indicate the possible effects this would have on the environment. [2]

Effects	True	False	Not possible to tell
This will lead to soil erosion.			
The soil will become less fertile.			
This may lead to global warming that would cause sea level to rise.			
Plants in the surrounding areas will be eaten up by the surviving animals.			

35. The diagram below shows 3 types of fishes, P, Q and R. The fishes live amongst the water plants in a river. A predator of the 3 types of fishes is introduced into the river.

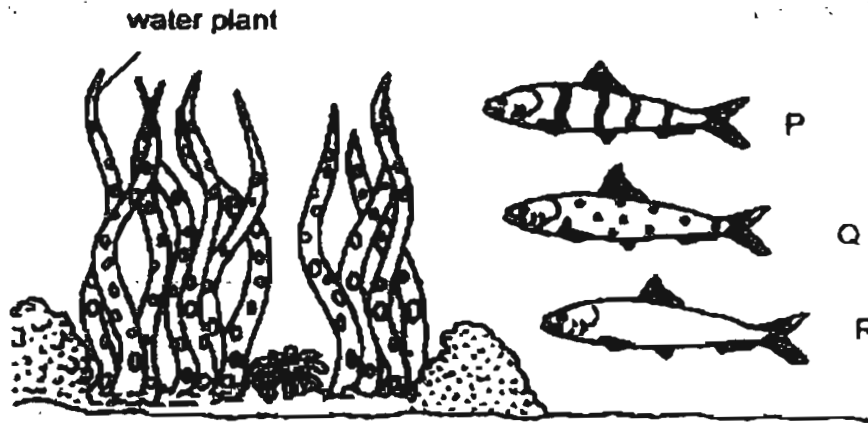

- a) Based on the diagram, which fish, P, Q or R would most likely have the greatest decrease in numbers. Explain your answer. [1]

- b) After a few years, a similar type of fish, S, appeared in the river and began to increase in number more than the other 3 fishes. In the space below, draw the likely body pattern of Fish S. [1]

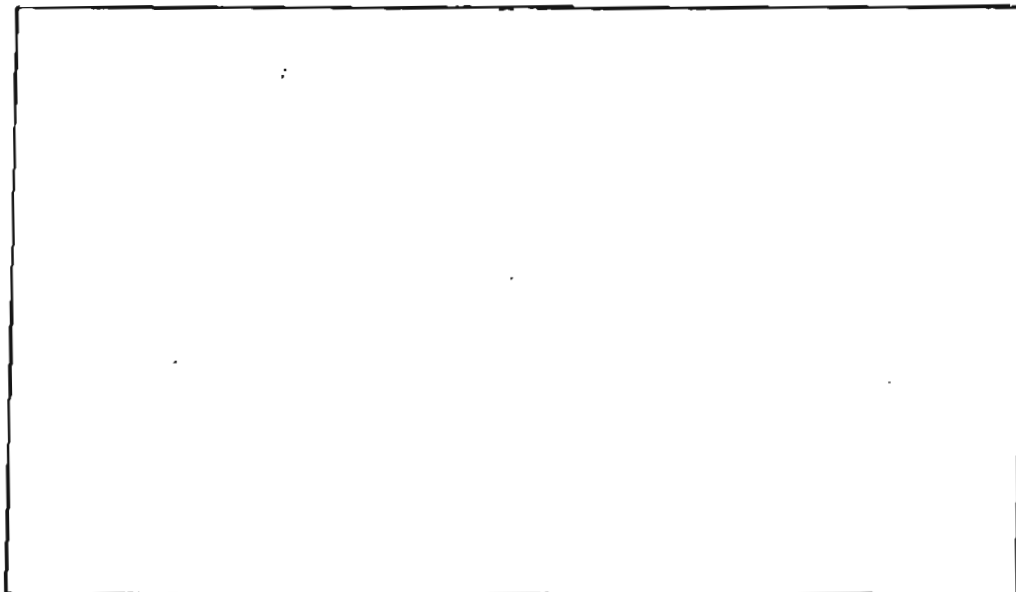

Fish S

36. The following diagram shows the concept map about roots. Fill in the blanks with the correct words. [2]

a) _____

b) _____

Those found in plants with weak stems and help the plants to reach for light.

Those found in mangrove and help them to get fresh air.

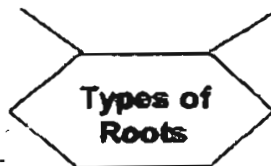

Those found in plants which can grow vegetatively.

Those found hanging down from branches and can help plants to breathe.

c) _____

d) _____

37. The tomato plant has a life cycle as shown below.

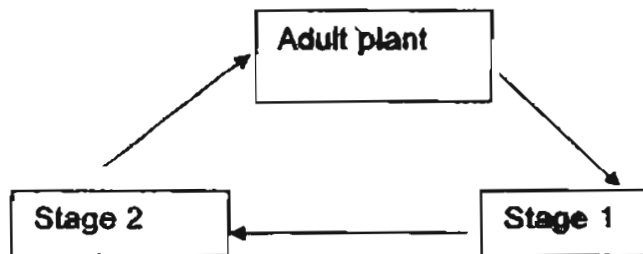

a) What are stages 1 and 2 in the life cycle called? [1]

Stage 1: _____

Stage 2: _____

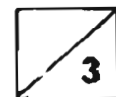

Handwritten signature or mark

37b. Study the flowchart below carefully.

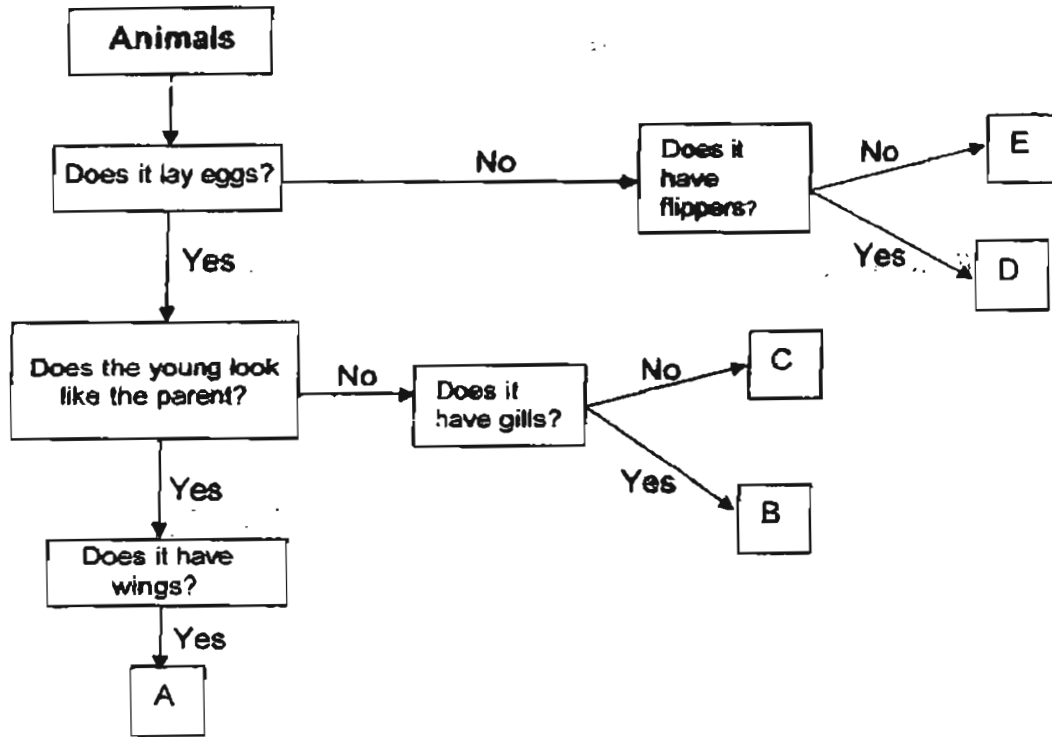

i) Based on the flowchart above, describe Animal E. [1]

ii) Study the flowchart carefully and write the correct exit point beside each animal. (Points A to E are called exit points) [1]

Butterfly: _____

Hen: _____

Seal: _____

Dog: _____



St

P3 38a) Study the classification table below and provide the most suitable heading for each group of plants. [1]
 P4

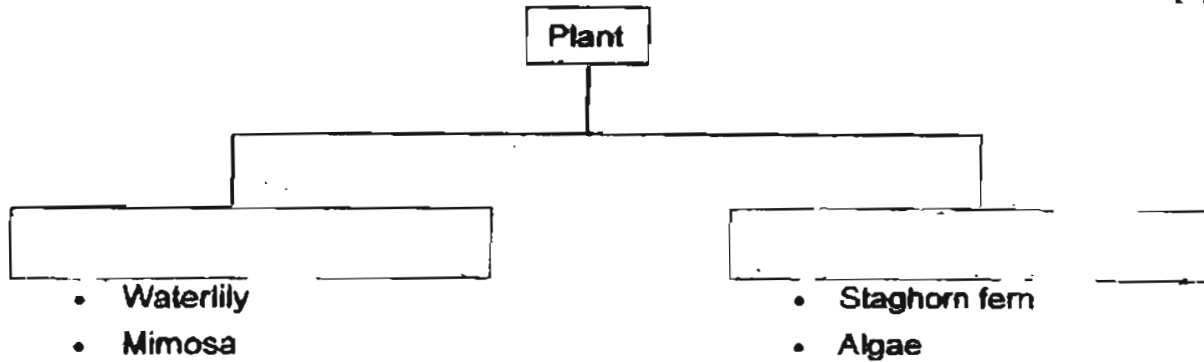

P6 38b) Siew Lian wanted to find out the effect Soap A and Soap B had on guppies. She prepared three set-ups and put them at the same place. She then observed them for a few days. An example of the set-up is shown below.

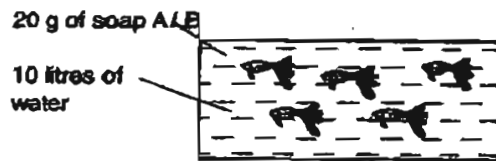

i) Which variable/s should Siew Lian keep the same to ensure a fair test? Tick the appropriate columns in the table. [1]

Variable	Kept the same
Amount of food	✓
Amount of water	✓
Number of guppies	✓
Type of soap	

ii) Draw and label what the control should be for this experiment. [1]

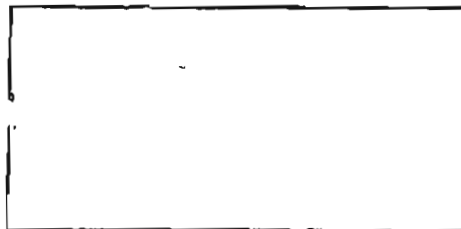

iii) Give a reason why water which has been used for washing clothes should not be allowed to flow into a river. [1]

39a) Some magnets exist naturally. They are called _____ [1]

39b) Some magnets can also be made out of magnetic materials. The magnets can be made in different ways. One of the methods is by using electricity as shown in the diagram below.

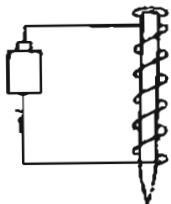

State two ways in which we can determine that the iron nail has been magnetised. [1]

- i) _____
- _____
- ii) _____
- _____

40. The following is a flowchart about states of matter.

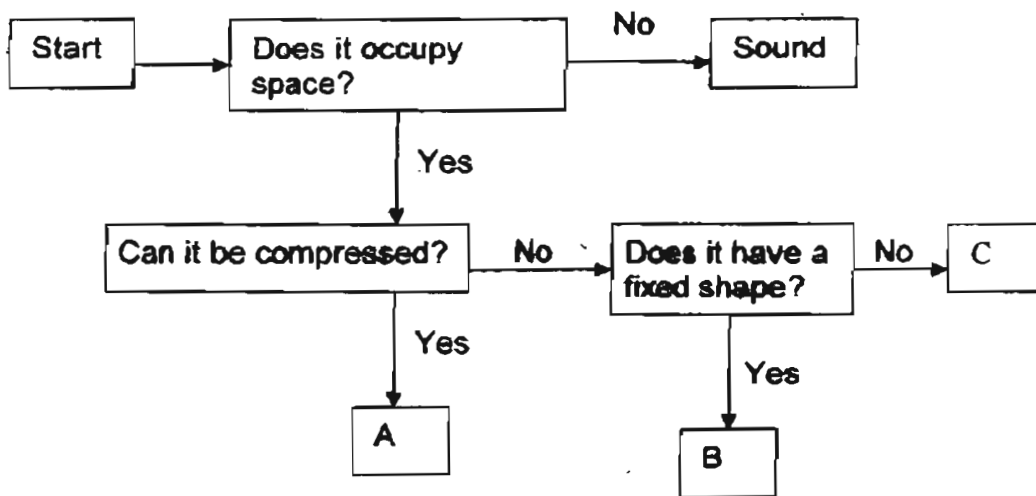

Identify A, B and C. [1]

A: _____

B: _____

C: _____

41. Farid measured the temperature of the air inside a covered glass container.

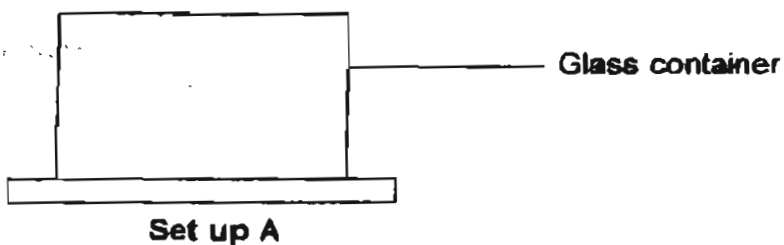

She then placed a lighted lamp inside the same covered container as shown below. One hour later, she took the temperature of the air inside the container

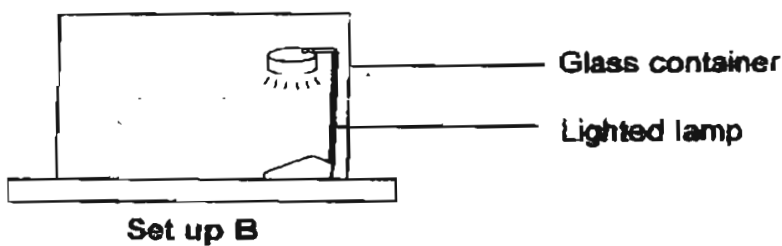

a) What happened to the temperature in Set up B? [1]

b) Explain your answer in a). [1]

42a). Which graph A, B, C or D represents the relationship between the distance of a planet from the sun and the time taken for it to make one complete revolution?
 [1]

Graph _____

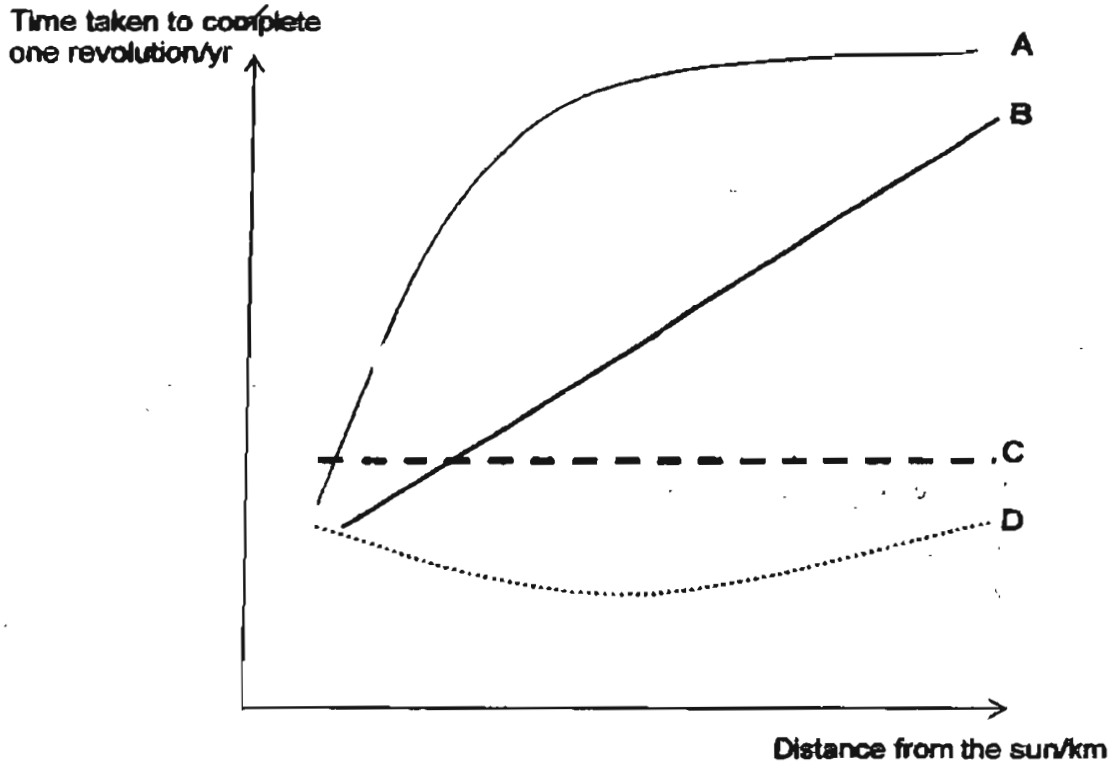

42b) The table below contains some information about 2 planets in a certain solar system.

	Atmospheric composition	Availability of water
Planet M	Carbon dioxide 5%, Nitrogen 80%, Oxygen 15%	Traces of water found under the crust of the planet.
Planet N	Nitrogen 65%, Oxygen 32%, Rare gases 3%	No evidence of water

If you are a space explorer who wishes to find a new habitat, which planet would you choose and why?
 [2]

43. The diagram below shows a circuit with 3 bulbs, X, Y and Z.

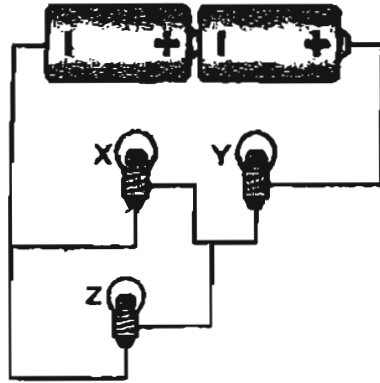

- a) A switch is placed in the circuit so that it controls only bulb X. Mark a cross (X) on the circuit above to show where the switch should be placed. [1]
- b) State what will happen if bulb Y fuses. [1]
-
- c) What is the advantage of connecting Bulbs X and Z in the manner shown in the diagram above? [1]
-

44. Look at the 3 simple machines below.

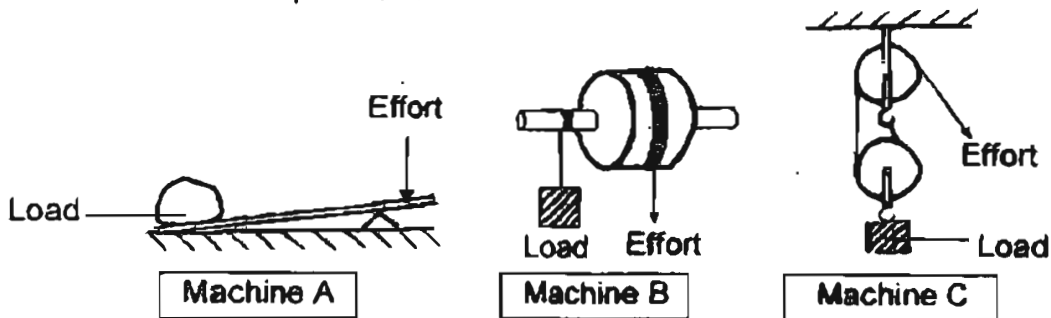

- a) What is one similarity that Machines A, B and C have? [1]
-
- b) Machine A is different from Machine B and C. Write down one main difference. [1]
-

45. We cannot see a force but we can usually see its effects as it interacts with objects around us. Give 2 examples of such effects. [2]

46a) How does heat travel? [1]

46b) The diagram below shows a metal rod heated by a bunsen burner.

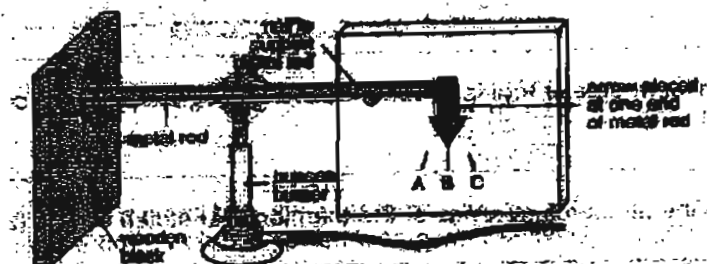

i) State the conversion of energy that took place in the above set-up. [1]

ii) State your observation of the arrow when the metal rod is heated for half an hour. [1]

iii) Explain your answer in (ii).

End of Paper

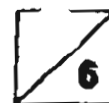

CATHOLIC HIGH SCHOOL
 PRIMARY SIX
 PRELIMINARY EXAMINATION 2005
 PRELIMINARY EXAMINATION 2005
 SCIENCE

01.	(1)	11. 4	21. 2
02.	(1)	12. 4	22. 2
03.	(4)	13. 2	23. 3
04.	2	14. 2	24. 2
05.	4	15. 4	25. 4
06.	4	16. 3	26. 1
07.	3	17. 2	27. 4
08.	4	18. 3	28. 1
09.	(2)	19. 4	29. 1
10.	4	20. 2	30. 4

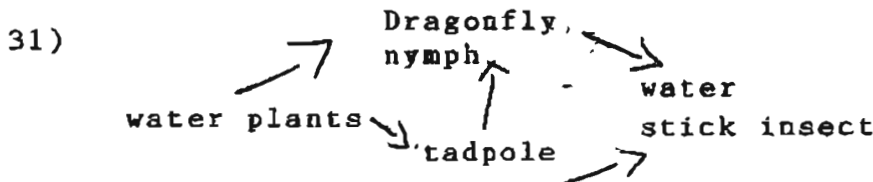

- 32) a) Hinge Straight
- b) Tick stopwatch
- c) i) He should have taken his pulse rate before running to get his original pulse rate.
 ii) He would then know what is his normal pulse rate.

- 33) a) Chlorophyll and carbon dioxide
- b) i) Photosynthesis takes place in plant but respiration takes place in both animals and plants. Oxygen is released when photosynthesis takes place but carbon dioxide and water vapour are released when respiration takes place. The raw materials for photosynthesis are water and carbon dioxide while raw materials for respiration are sugar and oxygen. During photosynthesis, energy is stored whereas during respiration, energy is released. Photosynthesis takes place only when there is light but respiration takes place all the time.
- ii) When living organisms respire, we get energy to carry out life processes.

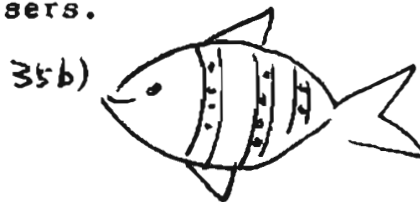

- 35) a) Fish R will decrease the most. Fish P and Q both have patterns on their body that are similar to the water plants, thus they can hide in the water plants. Fish R does not have any patterns on its body.

b)

- 36) a) clasping roots b) breathing roots
 c) storage roots d) aerial roots

37) a) Seed

Seedling

b) i) It is an animal that does not lay eggs and does not have flippers.

ii) C

A

D

E

38) a) Flowering plants Non-flowering plants

b) i)

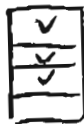

ii)

iii) The soap from the water will kill the organisms that live in the water as they can not survive in soap.

39) a) lodestones

b) i) Suspend the iron nail freely and check if it points in the north south direction. Bring the magnetized nail near to a compass. If the needle spins, then the nail is magnetised.

ii) Bring the iron nail near a paperclip to test if it could attract the paper clip.

40) A : Gaseous

B : Solid

C : Liquid

41) a) The temperature was warmer than Set-up A

b) The lighted lamp gives off unwanted heat into the surroundings, thus making it warmer.

42) a) B

b) I would choose to visit Plant M as there are only a bit of difference from Earth. The planet has water which enable life processes to take place. The gases in the air only a bit different from Earth.

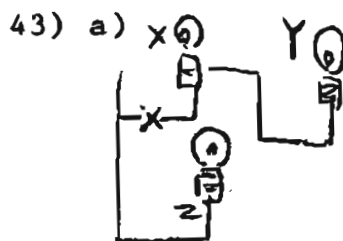

b) There will be a gap and the electricity will not be able to flow and the other two bulbs will not be able to light up.

c) Each bulb can function independently even if one bulb fuses.

94

44) a) The effort moves downwards.

b) Machine A uses more effort to lift up the load while machine B and C uses less effort to lift up the load.

45) Making a stationary ball move.

Making a moving ball stationary.

46) a) It travels from a warmer place to a colder place.

b) i) Chemical potential energy --- heat energy + light energy.

ii) Arrow will point slightly towards position C.

iii) When the metal rod is heated, it expands and pushes the arrow slightly towards position C.

7/2 250 -
95