

NAME : \_\_\_\_\_ ( )

CLASS : \_\_\_\_\_

INDEX NO.

--	--	--	--	--	--	--

SA2

**METHODIST GIRLS' SCHOOL ( PRIMARY )**

**PRELIMINARY EXAMINATION 2004**

**PRIMARY SIX**

**SCIENCE**

**BOOKLET A**

BOOKLET	MARKS
A	/ 60
B	/ 40
TOTAL	

Total time for Booklets A and B : 1 hr. 45 min.

Booklet A : 30 Questions ( 60 marks)

**DO NOT OPEN THIS BOOKLET UNTIL YOU ARE TOLD TO DO SO.**

**FOLLOW ALL INSTRUCTIONS CAREFULLY.**

**SECTION A ( 60 marks )**

For each question from 1 to 30 , four options are given. One of them is the correct answer.  
Choose the best answer and shade the correct oval (1, 2, 3 or 4 ) on the Optical Answer Sheet.

1. Which of the statements below about plants are true ?

- A . Plants are food producers.
- B. All plants reproduce naturally from seeds .
- C. Fungi photosynthesize only in the presence of light .
- D. Some plants can photosynthesize even if the leaves are not green in colour.

- 1. A and B only
- 2. A and D only
- 3. B and C only
- 4. A , B and D

2. The population of submerged plants in a pond was found to be decreasing .  
What has caused this to happen ?

- A. An increase in the number of water snails .
- B. The muddy condition of the water .
- C. An increase in the number of dragonfly nymph.

- 1. A only
- 2. B only
- 3. A and B only
- 4. A and C only

3. Some animals have special features to protect themselves from the cold and predators.  
Which of the following are these adaptations ?

- A. a thick coat of fur
- B. a thick layer of fat
- C. ability to store large amounts of oxygen
- D. body coverings which camouflage the animals

- 1. A and B only
- 2. A , B and C only
- 3. A , B and D only
- 4. A , B , C and D



4 The diagram below shows a yeast cell . It can increase in number by budding.

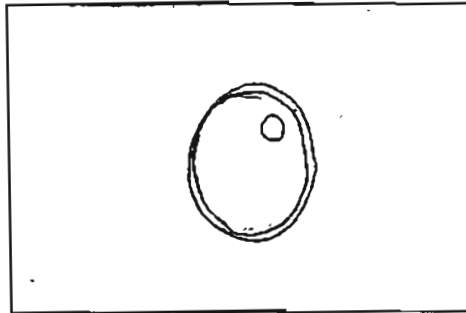

A Yeast Cell

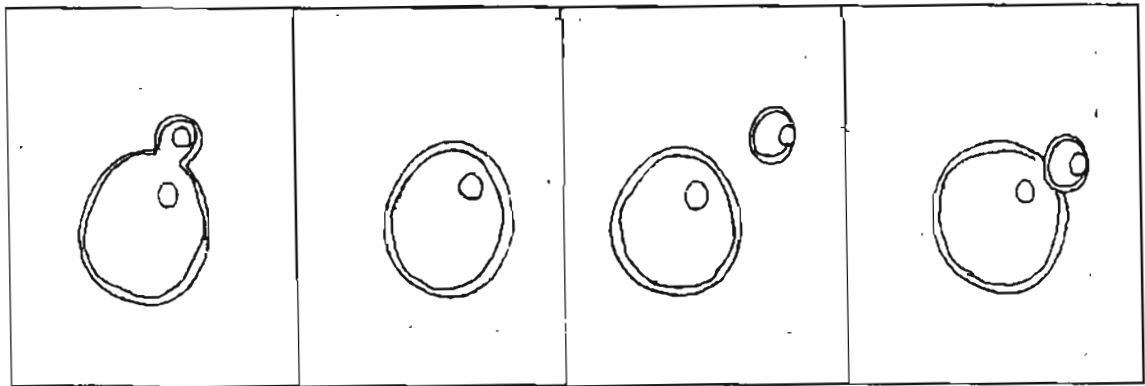

A

B

C

D

Arrange the diagrams above in the correct order to show how the process takes place.

1. A , C , B , D
2. B , A , D , C
3. C , D , B , A
4. D , B , C , A

5. Which of the following statements about cells is/are true ?

- A. The cell is a single unit of life.
- B. Cell division is necessary for an organism to grow .
- C. Organisms such as paramecium are made up of many cells.

1. A only
2. B only
3. A and B only
4. B and C only

6. The white spot on the surface of the egg yolk is the new cell as shown below. The diagram below shows the development of the cell six days later.

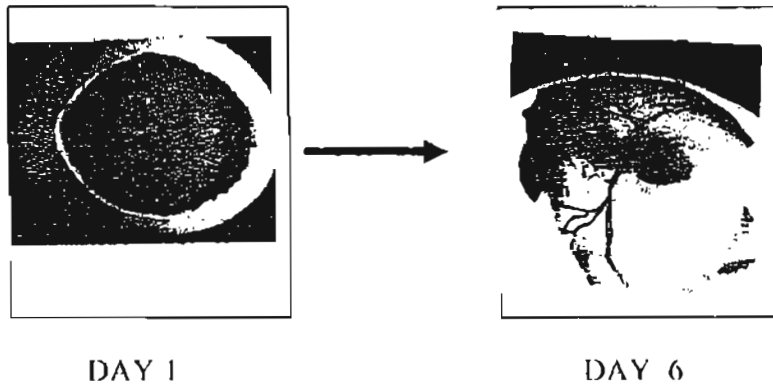

Which of the following statements are correct ?

- A. The embryo has a heart that is beating.
- B. Feathers and wings have developed .
- C. The embryo uses the food in the egg yolk to grow.
- D. The new cell is formed from the union of the male and female sex cells.

- 1. A and B only
- 2. B and C only
- 3. A , B and C only
- 4. A , C and D only

7. Study the family tree below .

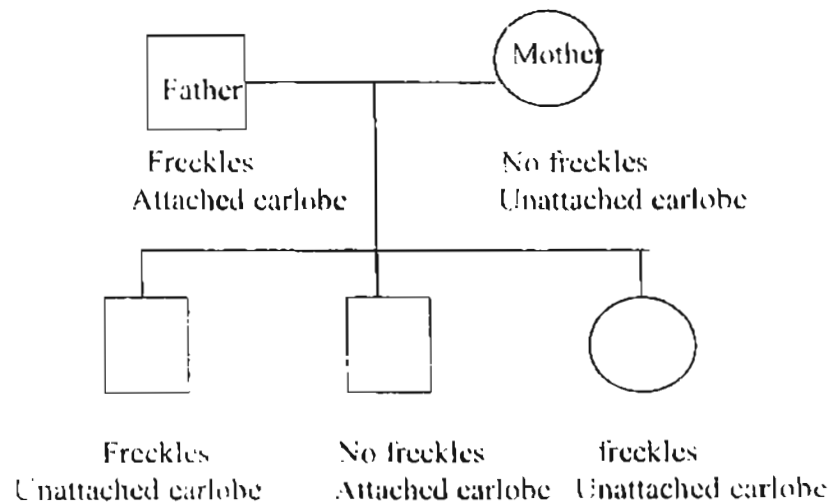

What is the characteristic that the only girl in the family inherits from her mother ?

- 1. freckles
- 2. no freckles
- 3. attached earlobe
- 4. unattached earlobe

8. Study the table below.

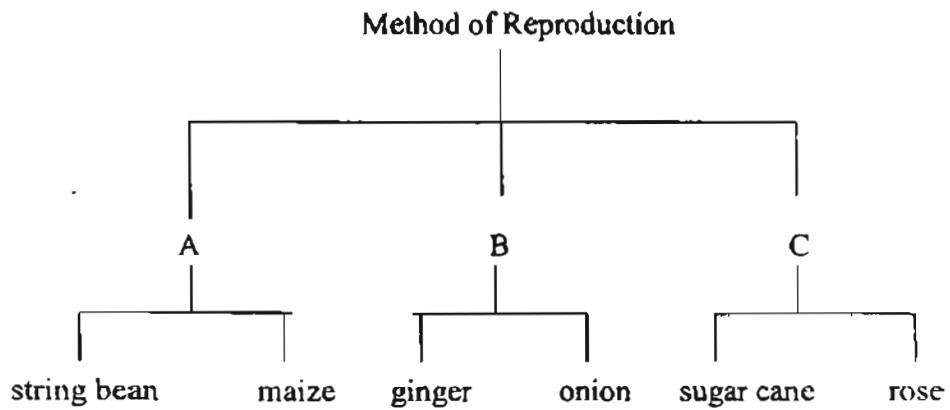

Which of the following plants can be grouped under “ B ” ?

1. potato and carrot
2. tapioca and pineapple
3. water chestnut and potato
4. banana and sweet potato

9. Look at the diagram below.

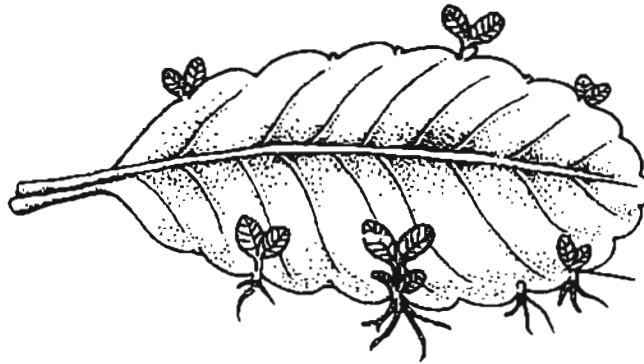

Which of the following plants is propagated by the method shown above ?

1. begonia and bryophyllum
2. banana and pineapple
3. African violet and moss
4. potato and sweet potato

10.



dragonfly nymph



grasshopper



butterfly



spider



caterpillar



ladybird

Classify the above animals into two groups such that there are three in each group.

**Group A**

1. With feelers
2. With wings
3. Live on land
4. Plant eaters

**Group B**

- Without feelers
- Without wings
- Live in water
- Plant and Animal Eaters

11.

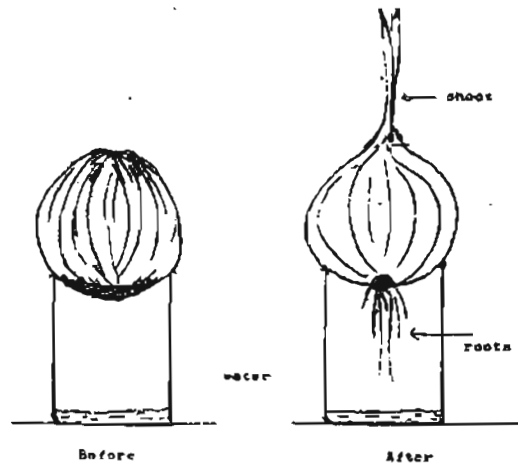

An old onion is placed resting on the brim of a glass jar as shown in the diagram. The set-up is then kept inside a dark cupboard for one week. Roots are seen growing towards the water and a new shoot is seen at the top of the bulb. Why is the onion able to grow in the dark ?

1. Darkness stimulates the growth of plants .
2. The young shoot needs only carbon dioxide to grow.
3. The onion has its own store of food to help the buds grow .
4. The onion is able to take all the nutrients from the water to help it grow in the dark.

12. Study the diagram below .

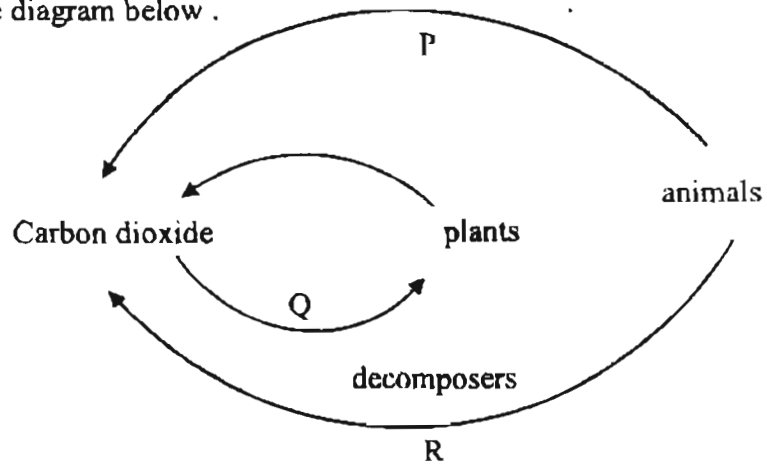

What are the processes P, Q and R ?

	P	Q	R
<del>1.</del>	photosynthesis	respiration	decomposition
<del>2.</del>	photosynthesis	decomposition	respiration
<del>3.</del>	respiration	photosynthesis	decomposition
<del>4.</del>	respiration	decomposition	respiration

13.

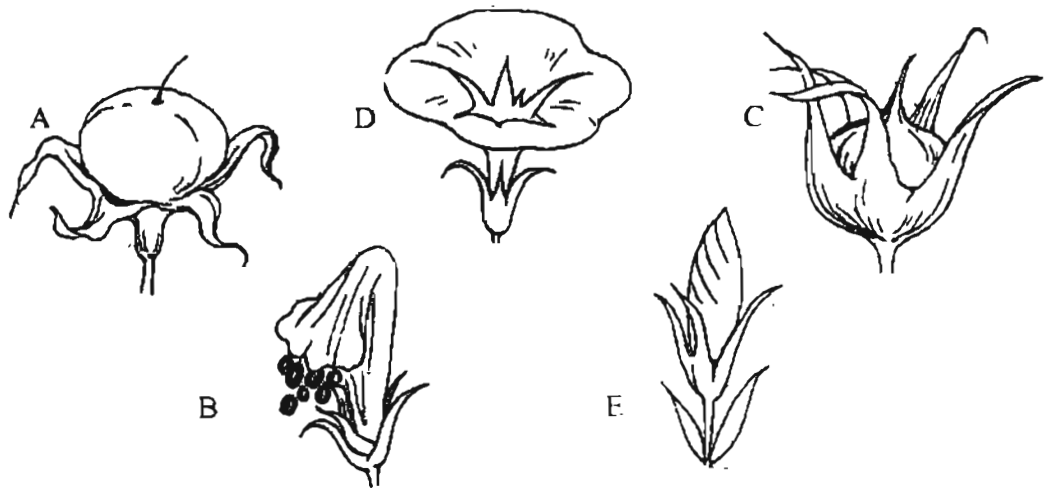

The diagrams above show the stages of development from a flower to a fruit .  
The correct order of development is \_\_\_\_\_.

1. B → E → A → D → C
2. E → D → B → C → A
3. E → C → B → A → D
4. A → B → C → D → E

14. The diagram below shows a human heart. Answer questions <sup>14</sup>15 and <sup>15</sup>14 using this diagram.

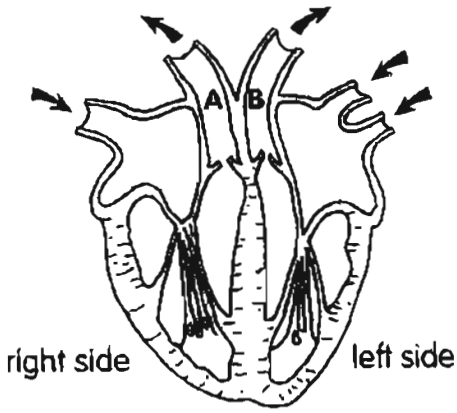

The vessel marked A \_\_\_\_\_.

- 1. carries blood to the lungs
- 2. collects blood from the body
- 3. collects blood from the lungs
- 4. carries blood to all parts of the body

15. The vessel marked B carries blood high in \_\_\_\_\_.

- 1. oxygen
- 2. carbon dioxide
- 3. digested food
- 4. waste materials



16. The diagram below shows a capped bottle with its end open in a trough of water.

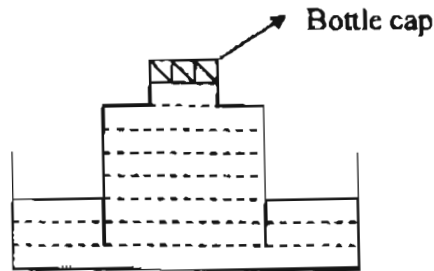

Which one of the following diagrams shows what would happen when the cap of the bottle is removed?

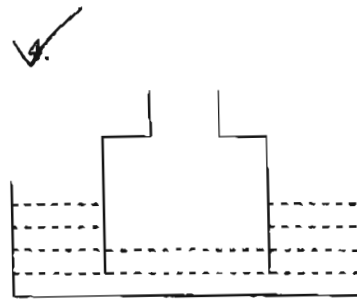
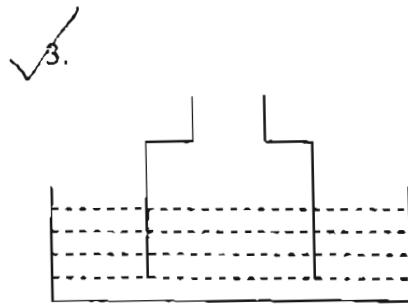
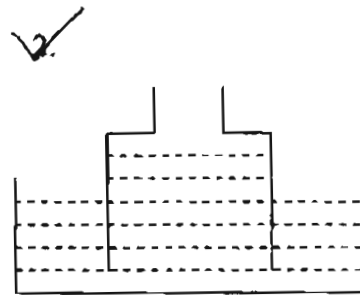
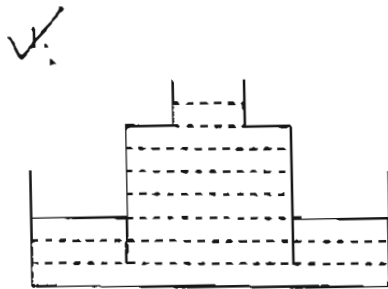

17. Liquid X is heated to a temperature of  $140^{\circ}\text{C}$  and left to cool in a room at  $30^{\circ}\text{C}$ . The graph below shows how the temperature of Liquid X changes over time.

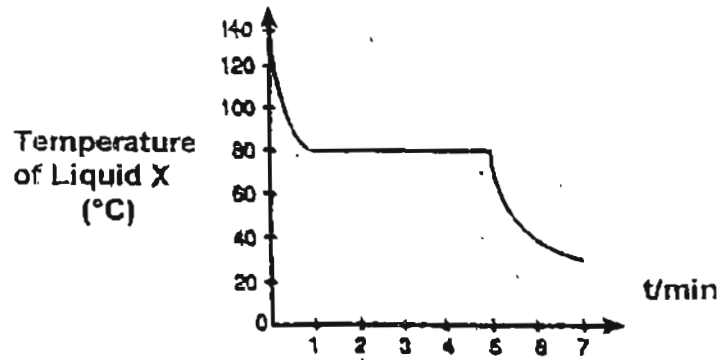

If the same liquid was placed in a room with a temperature of  $10^{\circ}\text{C}$ , which of the following would show the temperature change of liquid X over time?

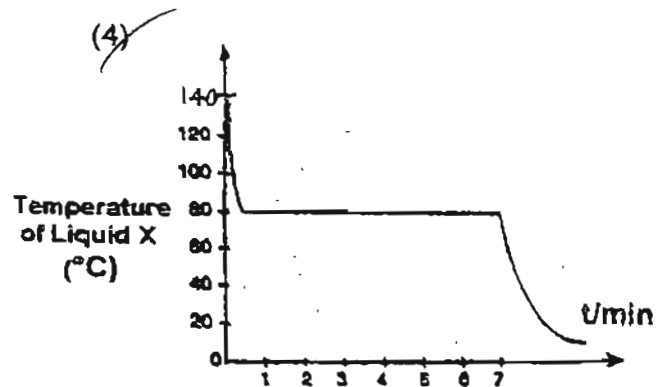
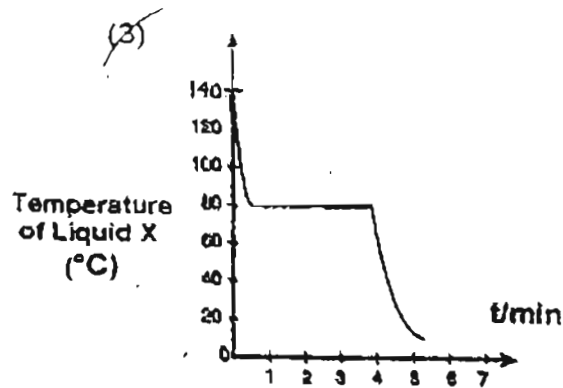
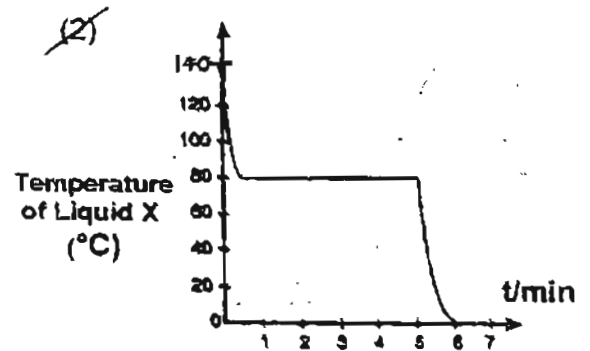
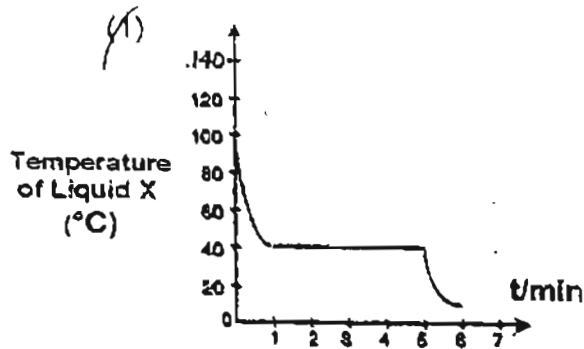

18. Three materials A, B and C are classified according to their properties as shown in the table below.

	A	B	C
Magnetic material	✓		
Good conductor of heat	✓		✓
Good conductor of electricity	✓		✓

Which of the following are A, B and C most likely to be?

	A	B	C
1.	Carbon	Styrofoam	Iron
2.	Steel	Carbon	Gold
3.	Aluminium	Wool	Carbon
4.	Iron	Plastic	Copper

19. The diagrams below show the different ways four 1.5 V batteries are arranged in a circuit. In which circuit will the bulb be the dimmest?

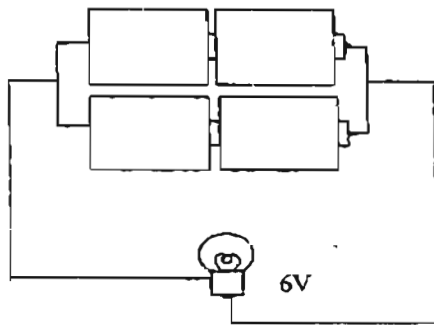

(1)

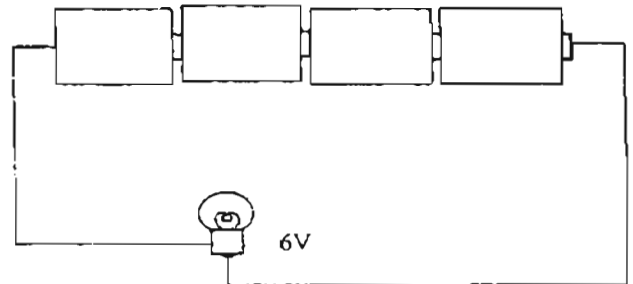

(2)

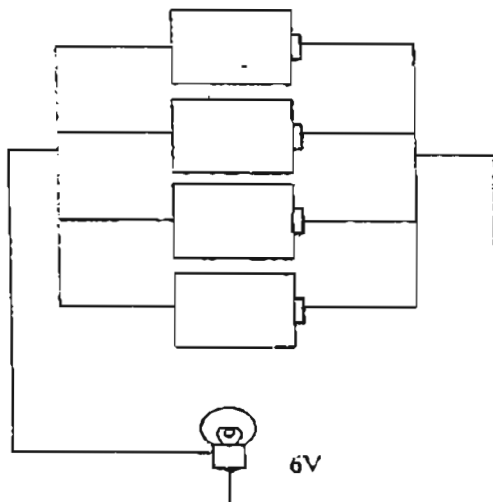

(3)

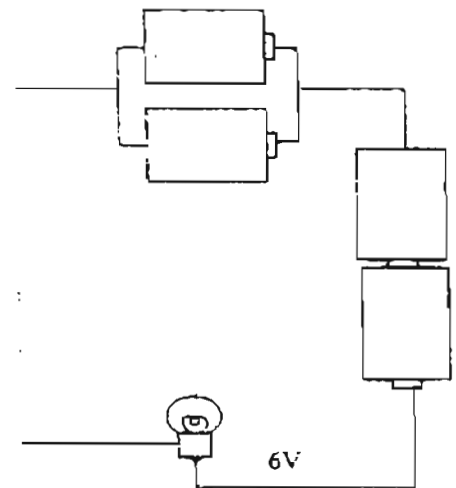

(4)

20. The diagram below shows 3 pulley systems A, B and C.

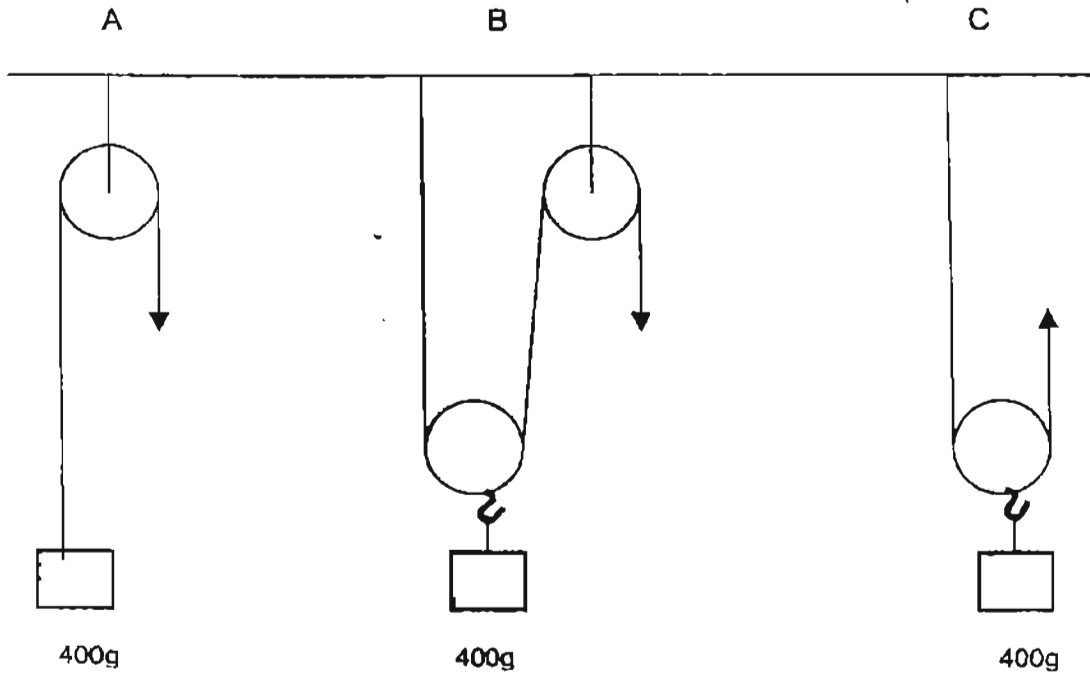

If a force of 230g is applied, which of the pulley systems can lift the load?

1. A only
  2. B and C only
  3. A and C only
  4. A, B and C
21. Karen recorded the lengths of the shadows formed by a pole at different time intervals. If the length of the shadow recorded at 12.30 p.m. was 50 cm, what could the lengths of the shadows be at 8 a.m. and 2 p.m. respectively?

	Length of shadow (cm)	
	At 8 a.m.	At 2 p.m.
1.	35	45
2.	40	55
3.	60	45
4.	70	60

22. The following diagram shows Planet X with its centre at Z (not drawn to scale). John, an astronaut, landed on Planet X. He walked on two locations, A and B. The distance of A from Z is 8000 km and the distance of B from Z is 1000 km

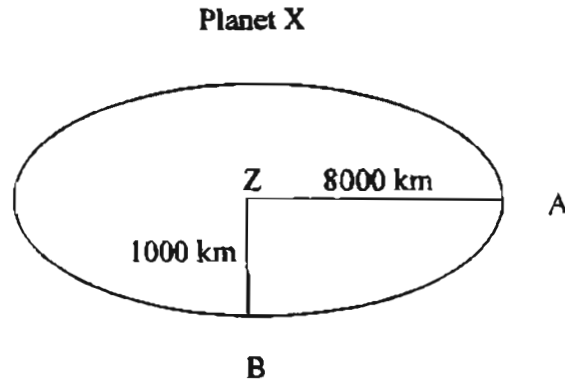

Which of the following statements are likely to be true?

- A. John weighs less at A than at B.
  - B. John has the same mass at A and B.
  - C. John will be able to jump higher at B than at A.
  - D. John will be able to lift heavy objects more easily at B than at A.
- 1. A and B only
  - 2. A and D only
  - 3. C and D only
  - 4. B, C and D only
23. Two magnets are placed next to each other. If 'X' is the South pole, what will most likely happen to the ping pong ball? It will \_\_\_\_\_.

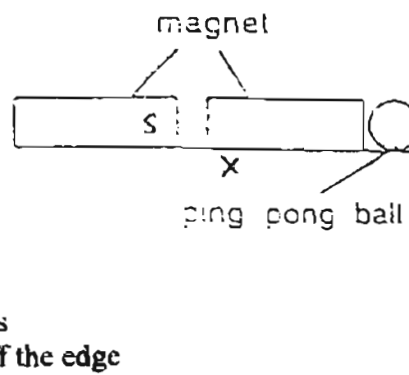

- 1. stay where it is
- 2. be knocked off the edge
- 3. move nearer to the magnet
- 4. move away from the magnet

24. In the picture below, John, who is standing behind the wall is able to see the fruit on the tree using a periscope. This is because light \_\_\_\_\_.

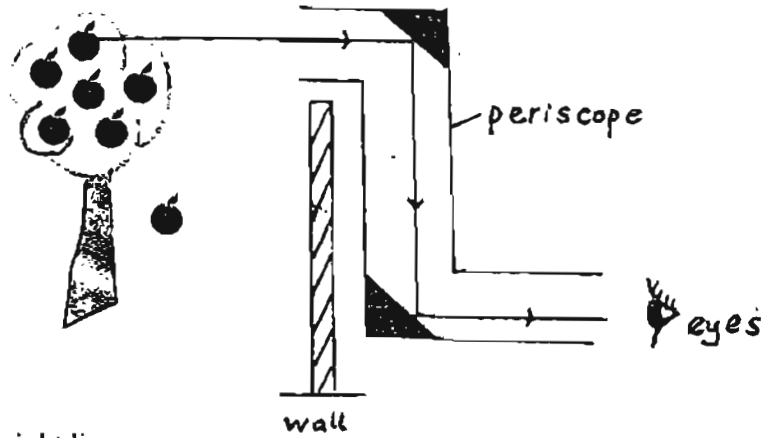

- A. travels in a straight line
- B. can travel through the wall
- C. can be reflected by the mirrors

- 1. A and B only
- 2. A and C only
- 3. B and C only
- 4. A, B and C

25. Three objects X, Y and Z are used to balance an object, A, as shown in the diagrams below. Arrange objects X, Y and Z in ascending order of their weights.

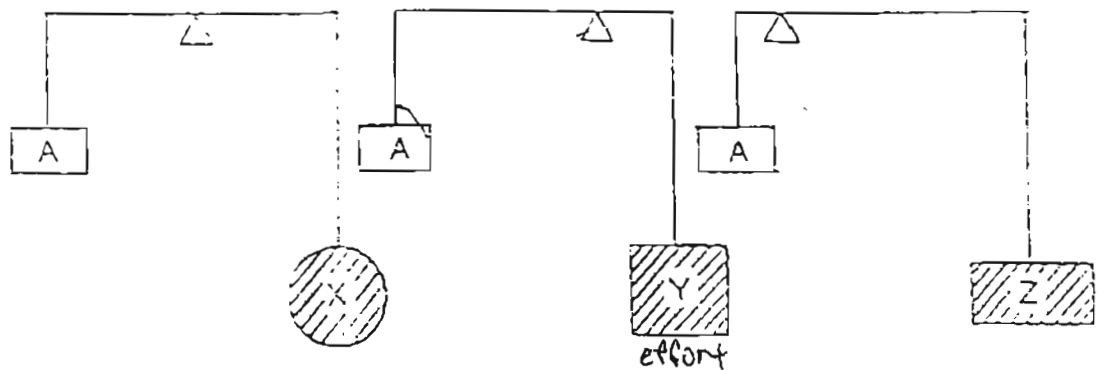

- 1. XYZ
- 2. YXZ
- 3. YZX
- 4. ZXY

26. The diagrams A, B, C and D below show the stages in the water cycle but not necessary in the correct order.

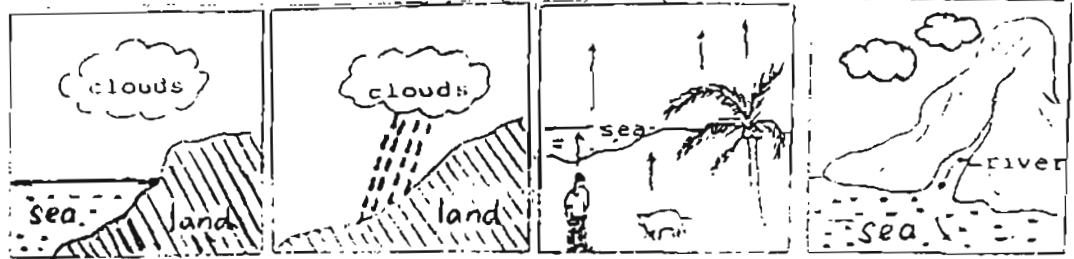

A: Clouds form over the land

B: Rain falls

C: Water evaporates from seas, rivers and living things

D: Water flows to the rivers and seas

Which of the following shows these stages in their correct order?

1.

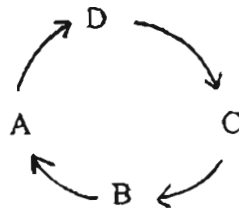

2.

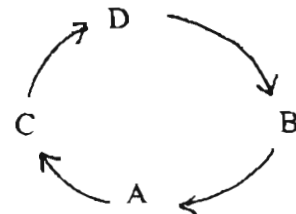

3.

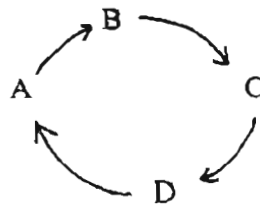

4.

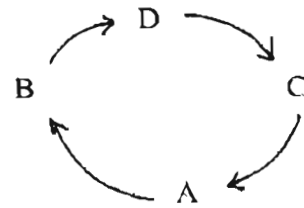

27. The diagram below shows the path of a ball after it was being thrown into the air.

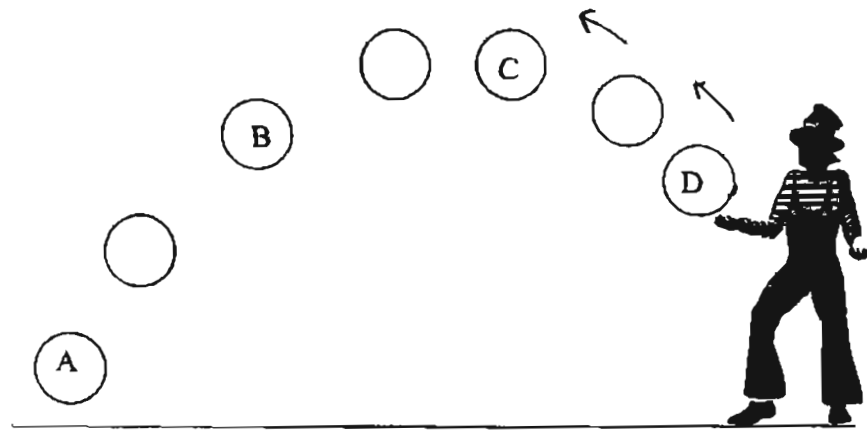

At which position A, B, C or D does the ball possess the most kinetic energy?

1. A
2. B
3. C
4. D



28. The diagrams below show the length of the same spring under different loads.  
(Diagrams are not drawn to scale)

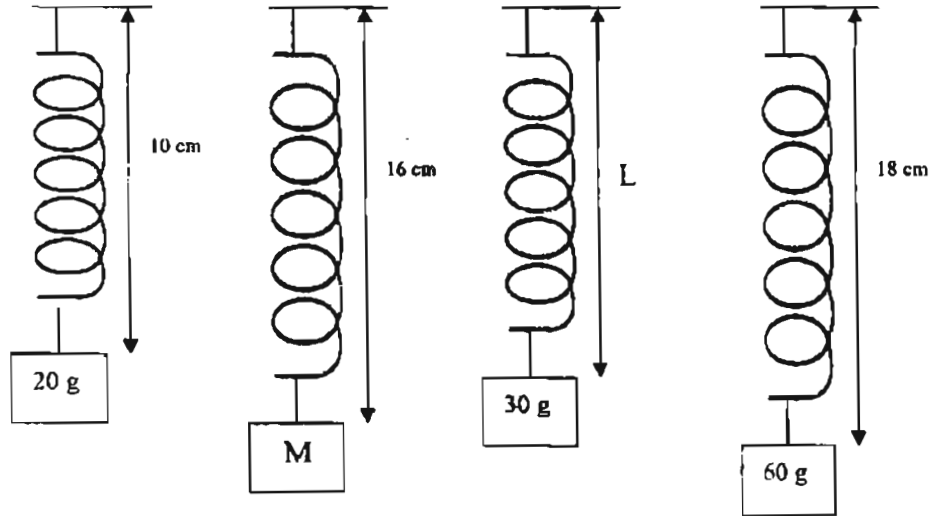

Which one of the following sets of values for 'M' and 'L' is correct?

	M (g)	L (cm)
1.	40	12
2.	50	12
3.	50	14
4.	40	14

29. You are given a classification key as shown below.

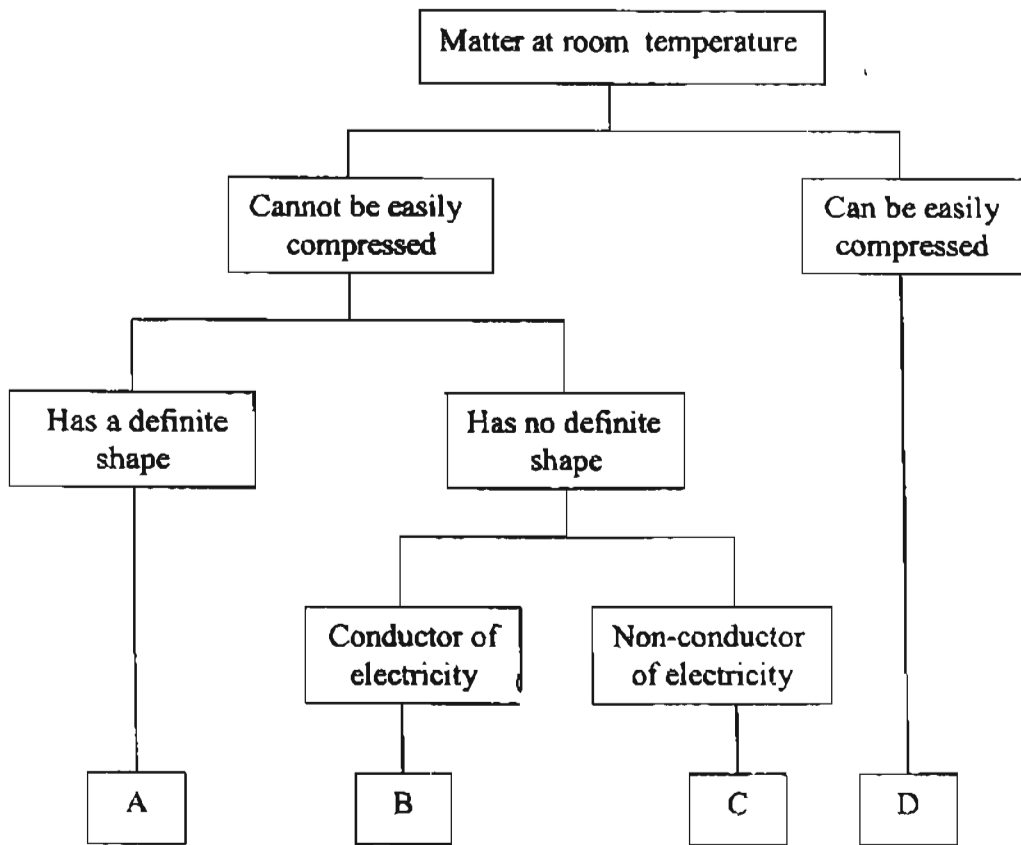

Which one of the following sets of items represents A, B, C and D correctly?

	A	B	C	D
1.	sand	mercury	oil	carbon dioxide
2.	water	vinegar	ice cubes	oxygen
3.	jelly	copper coin	rubber band	carbon dioxide
4.	ice cubes	water	mercury	nitrogen

30. Mary heated some water in containers A and B and measured the rate of evaporation. The amount of heat given to each container was the same.

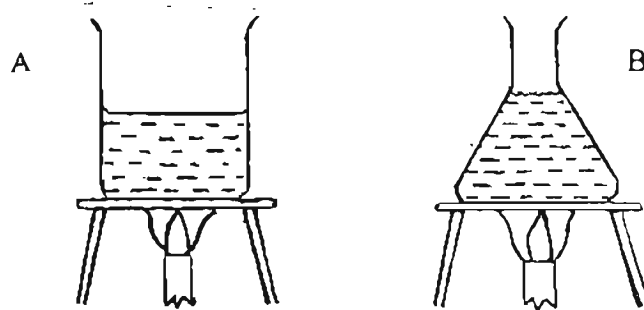

Which one of the following graphs shows the rate of evaporation **correctly**?

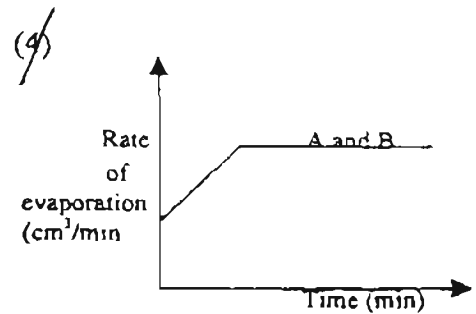
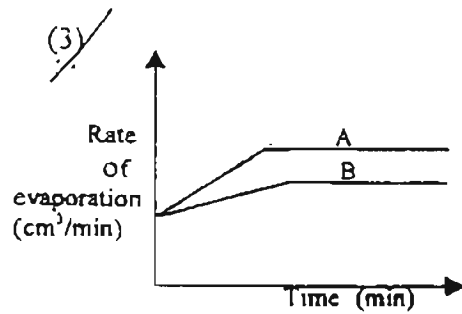
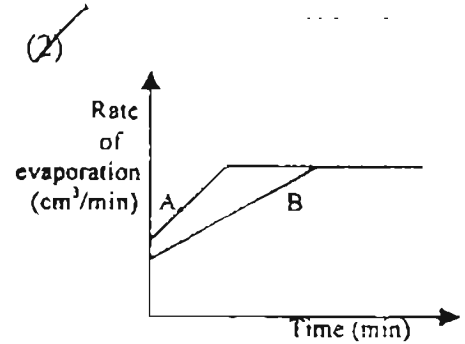
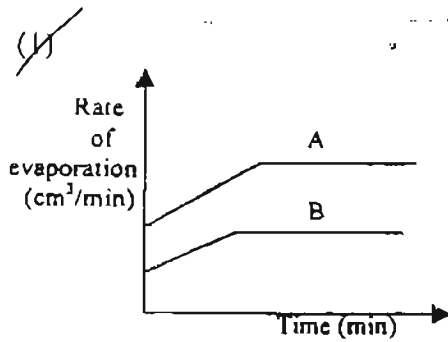

NAME : \_\_\_\_\_ ( )

CLASS : \_\_\_\_\_

INDEX NO

--	--	--	--	--	--

**METHODIST GIRLS ' SCHOOL ( PRIMARY )**

**PRELIMINARY EXAMINATION 2004**

**PRIMARY SIX**

**SCIENCE**

**BOOKLET B**

BOOKLET	MARKS
A	/ 60
B	/ 40
TOTAL	

Total time for Booklets A and B : 1 hr. 45 min.

Booklet B : 16 Questions ( 40 marks)

**DO NOT OPEN THIS BOOKLET UNTIL YOU ARE TOLD TO DO SO.**

**FOLLOW ALL INSTRUCTIONS CAREFULLY.**

**SECTION B ( 40 marks )**

Write your answers to questions 31 to 46 .

31. Micro- organisms are too small to be seen with the eye. They are all around us and they come in various shapes and forms .

a. Give two examples of micro- organisms. ( 1 mark )

\_\_\_\_\_

\_\_\_\_\_

b. Some micro-organisms are useful and some are harmful. In the table below state two ways in which they can affect us . ( 2 marks )

Helpful Micro-organisms	Harmful Micro-organisms
1.	1.
2.	2.

32. The diagram shows the muscles and bones of the arm .

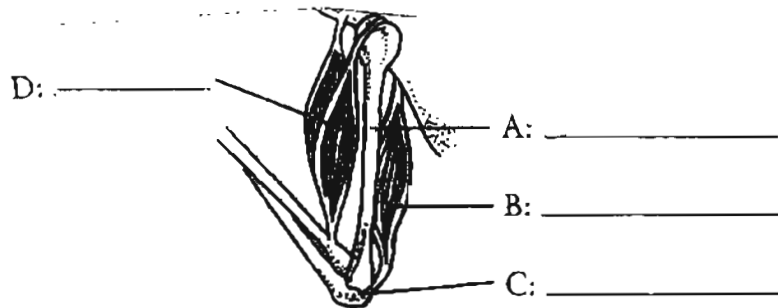

a. Write the word ' joint ' in the correct blank.

( 1 mark )

b. Muscles can be found just beneath our skin. .  
Name the two functions of the muscular system .

\_\_\_\_\_

\_\_\_\_\_

( 2 marks )

33. The diagram below shows an organ that belongs to part of a human body system .

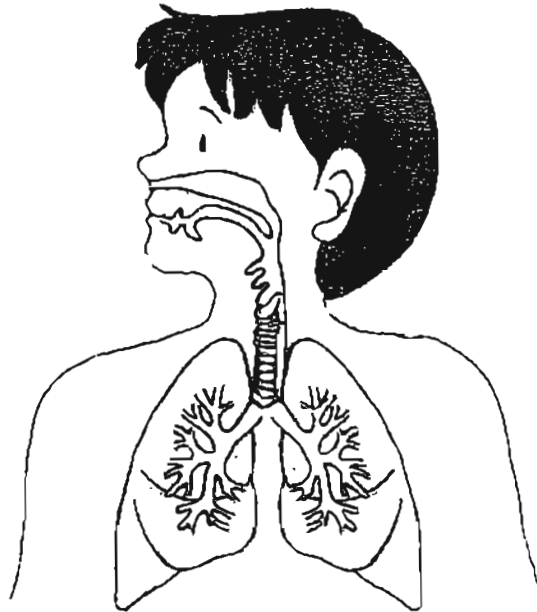

- a. Which system does this organ belong to ?

\_\_\_\_\_

( 1 mark )

- b. Give two functions of the system you stated in ( a )

\_\_\_\_\_

\_\_\_\_\_

( 1 mark )

- c. Explain how the above process is carried out in the plant system .

\_\_\_\_\_

( 1 mark )

34. Study the diagrams below that show two types of cells .



Cell X

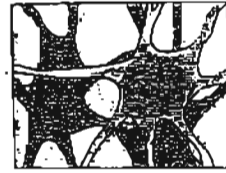

Cell Y

a. What is present in Cell X but absent in Cell Y ?

\_\_\_\_\_ ( 1 mark )

b. What is the function of the part mentioned in ( a ) ?

\_\_\_\_\_ ( 1 mark )

c. State one similarity between the two cells .

\_\_\_\_\_  
 \_\_\_\_\_ ( 1 mark )

35.

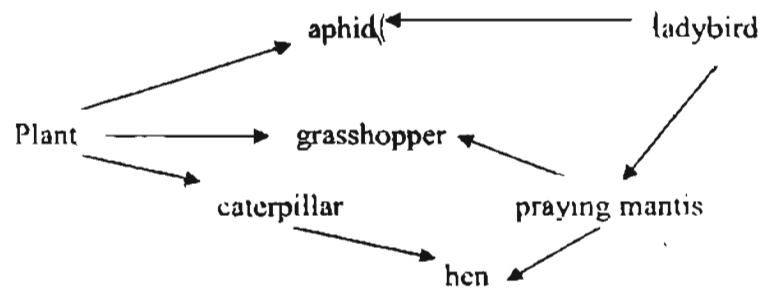

a. The organisms above form a community . Name the above community ( 1 mark )

\_\_\_\_\_

b. Some of the arrows are not correct. Circle the wrong arrows. ( 1 mark )

36. Look at the pictures below carefully .



Bird X



Bird Y

Describe how these birds adapt to their environment . Complete the graphic organizer below.

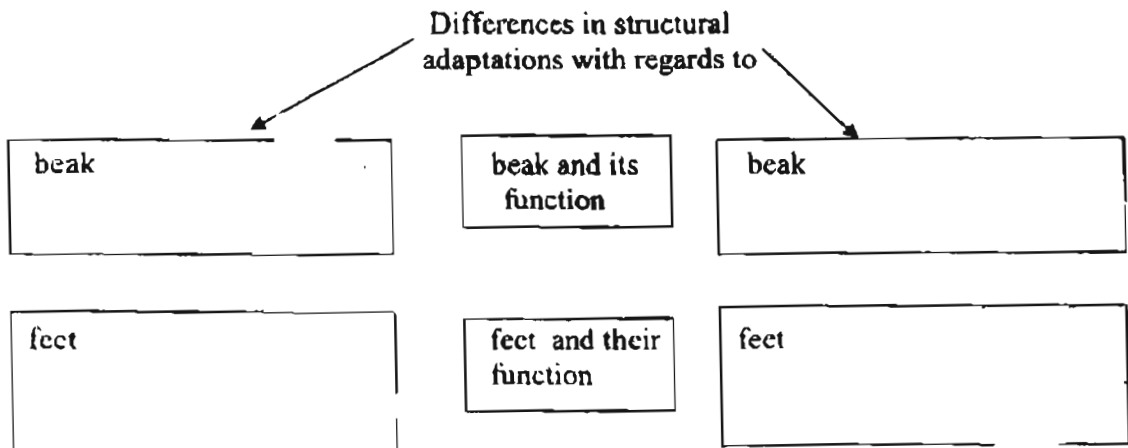

( 2 marks )



37. Study the diagram below carefully.

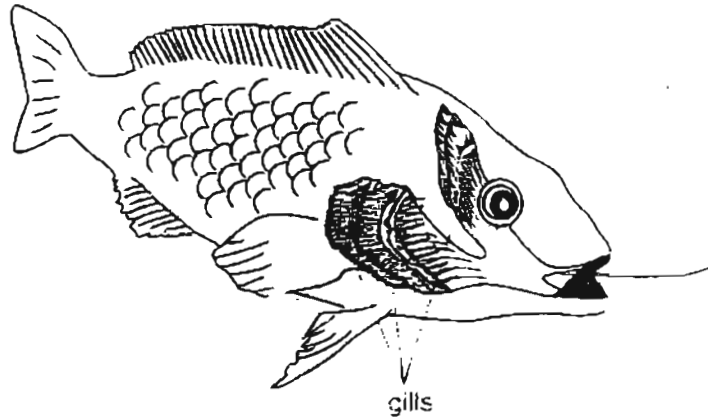

a. Describe how the gills help the fish to take in oxygen .

---

---

---

( 1 mark )

b. On the diagram draw arrows to show the flow of water entering and leaving the fish .

( 1 mark )

38. Study the diagram below.

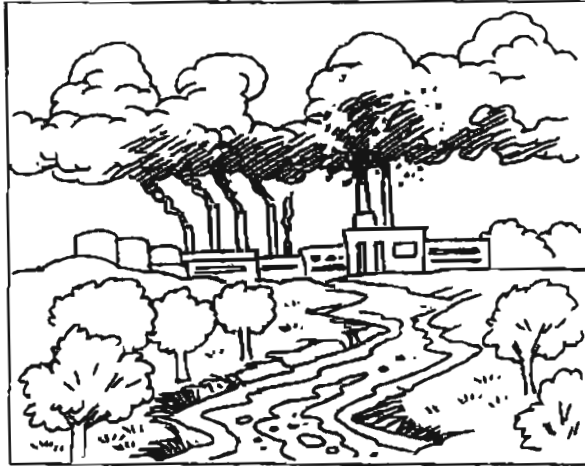

- a. Name any two possible pollutants found in this industrial town. ( 1 mark )
- b. State the effects these pollutants have on living things. ( 1 mark )

Pollutants	Effects
a.	
b.	

39. The diagram below shows a torchlight shining on a cardboard which has a cut-out heart-shape in a darkened room.

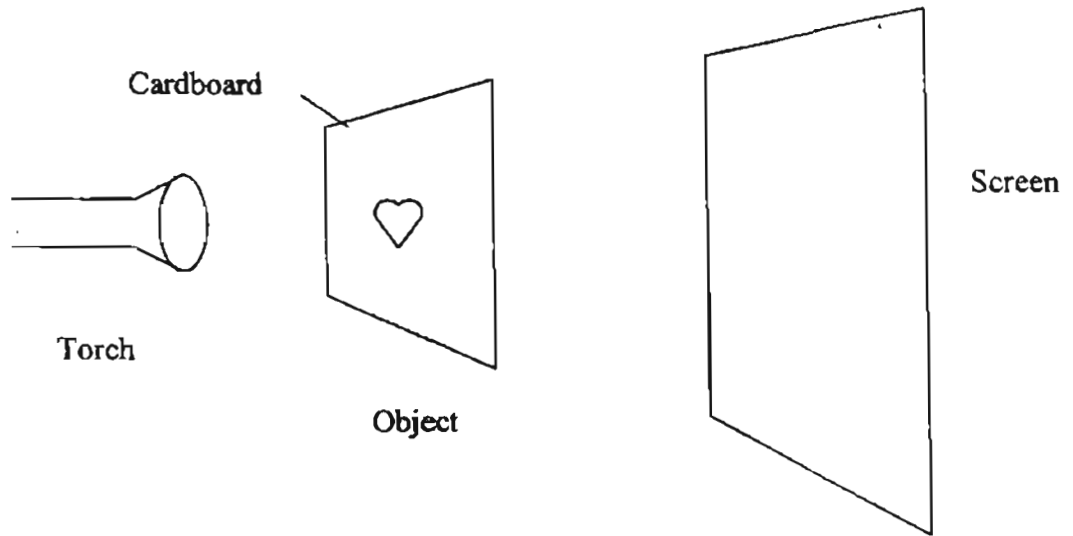

- a. Draw and shade the shadow you would see on the screen in the box below. (1 m)

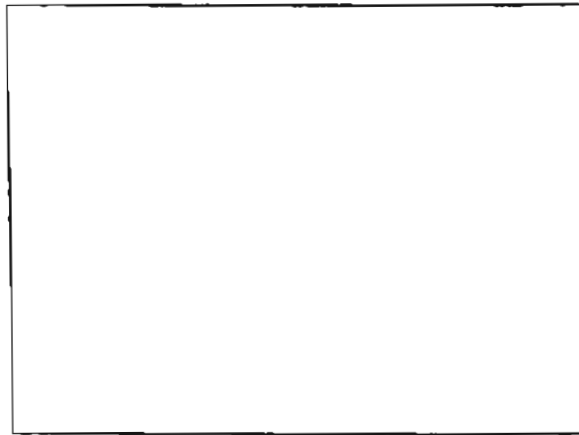

- b. What happens to the shadow if the object is brought nearer to the screen? (1 m)

---

---

---

40. The diagram below shows the positions of the Sun, Earth and Moon. The Moon rotates round the earth according to the direction given. The diagram is not drawn to scale.

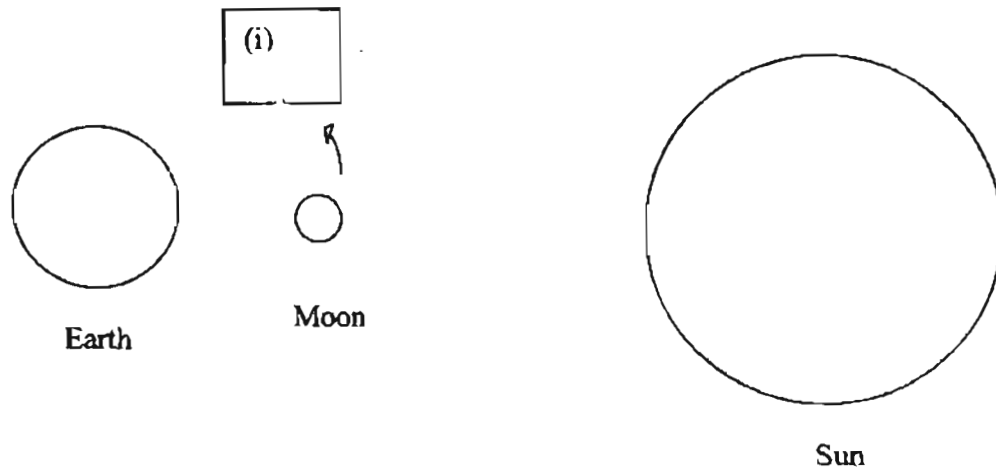

- a. In Box (i), draw the shape of the moon as it appears on the earth. (1 m)
- b. What is the name given to this moon-shape?  
It is a \_\_\_\_\_ . (1 m)
- c. How many days does the moon take to rotate round the earth in order to arrive at position (i)? (1 m)  
The moon takes about \_\_\_\_\_ days to arrive at position (i).

41. Ali made use of the flow chart below to find out whether an unknown object is a magnet, magnetic or non-magnetic material. The points A, B, C, D and E are called 'exit points'.

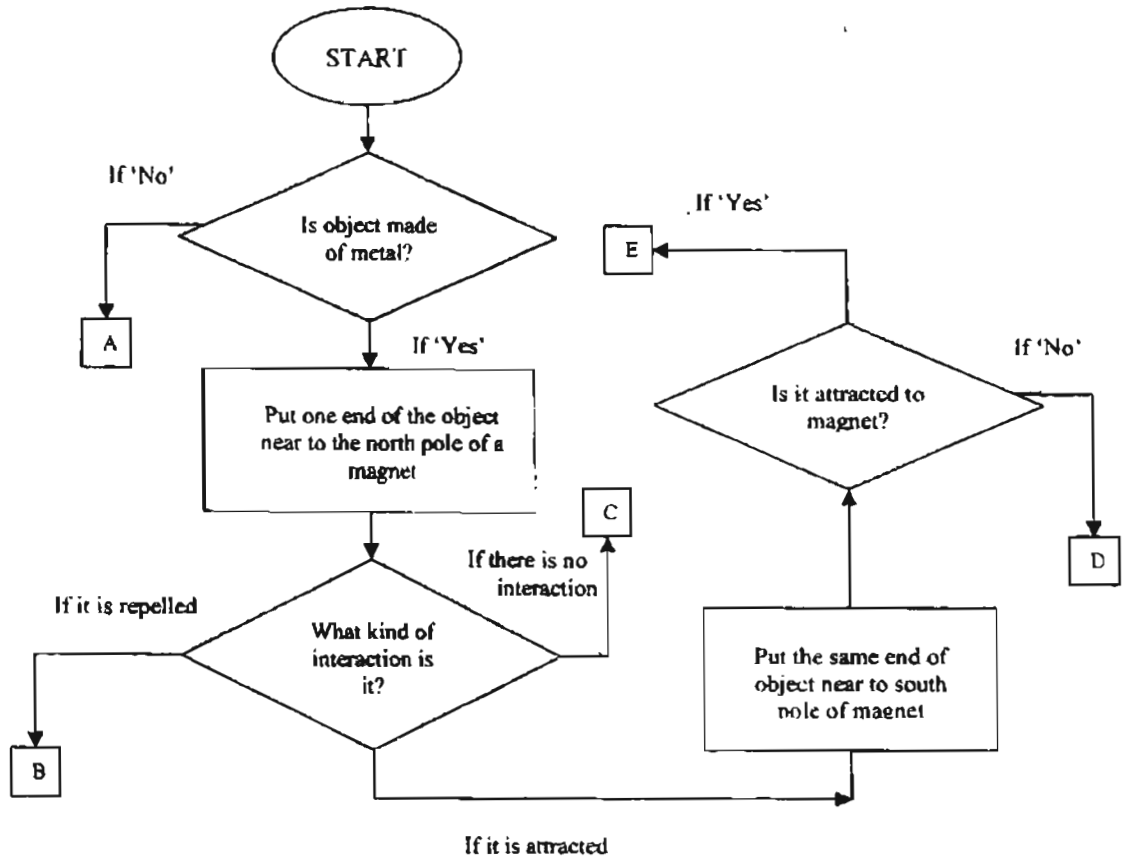

He carried out the whole process using each of the items given below. Write down the 'exit point' Ali would get for each of the objects below. (2 m)

	Object	Exit point
a.	Gold ring	
b.	Plastic spoon	
c.	Aluminium can	
d.	Steel nail	

42. Betty was given a set of gears as shown below.

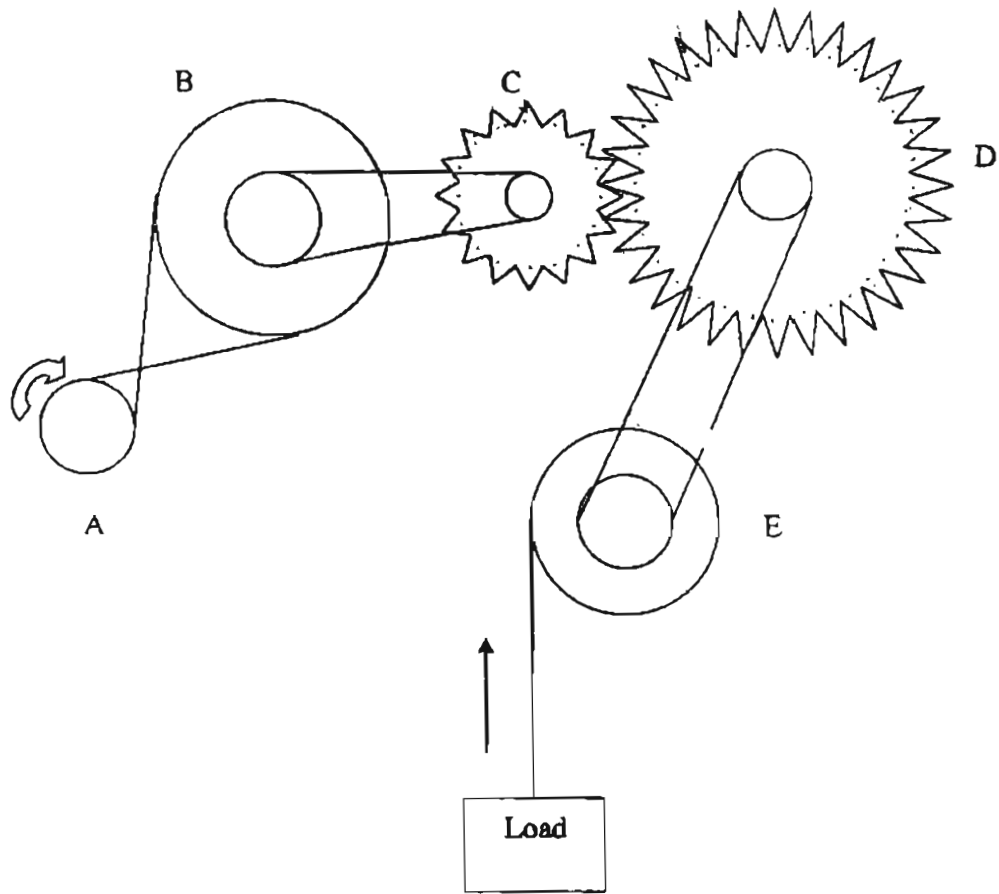

State the direction the wheel will turn in each of the following when wheel A moves in the direction as shown by the arrow in the diagram above. (2 m)

- Wheel B: \_\_\_\_\_ direction
- Wheel E: \_\_\_\_\_ direction
- When gear D makes 2 complete turns, how many complete turns will gear C make? (1 m)

Gear C: \_\_\_\_\_ complete turns

43. Three similar cans containing the same amount of the following substances - oil, sand and water are left standing in the sun for the same period of time. They are removed from sunlight and the temperatures of the substances are taken every 2 minutes. The results are tabulated as shown below.

Time in minutes	Oil °C	Sand °C	Water °C
0	45	50	40
2	43	42	39
4	41	39	38
6	39	36	37
8	37	33	36
10	35	30	35

- a. Based on the results above, which one of the 3 substances is best for retaining heat? (1 m)

---

- b. Give a reason for your choice in (a). (1 m)

---

---

- c. Name one variable that must be the same which is not mentioned in the procedure above to ensure it is a fair investigation. (1 m)

---

---

44. A plank of length 20 cm is inclined at different angles to the table as shown below. Sally conducted the experiment to investigate the relationship between the angle of the ramp and the amount of potential energy possessed by the block.

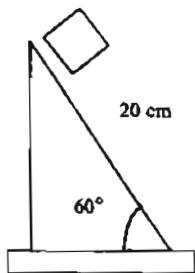

Ramp A

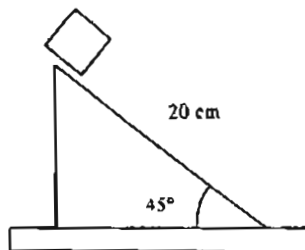

Ramp B

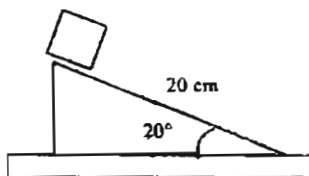

Ramp C

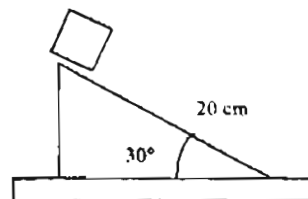

Ramp D

- a. What would she measure to determine the relationship between the angle of the ramp and the potential energy of the block? (1 m)

---

---

- b. How would she ensure that the results are reliable? (1 m)

---

---



45. The diagram below shows the changes in the states of water and its processes. Fill in the boxes with the correct processes to complete the diagram. (2 m)

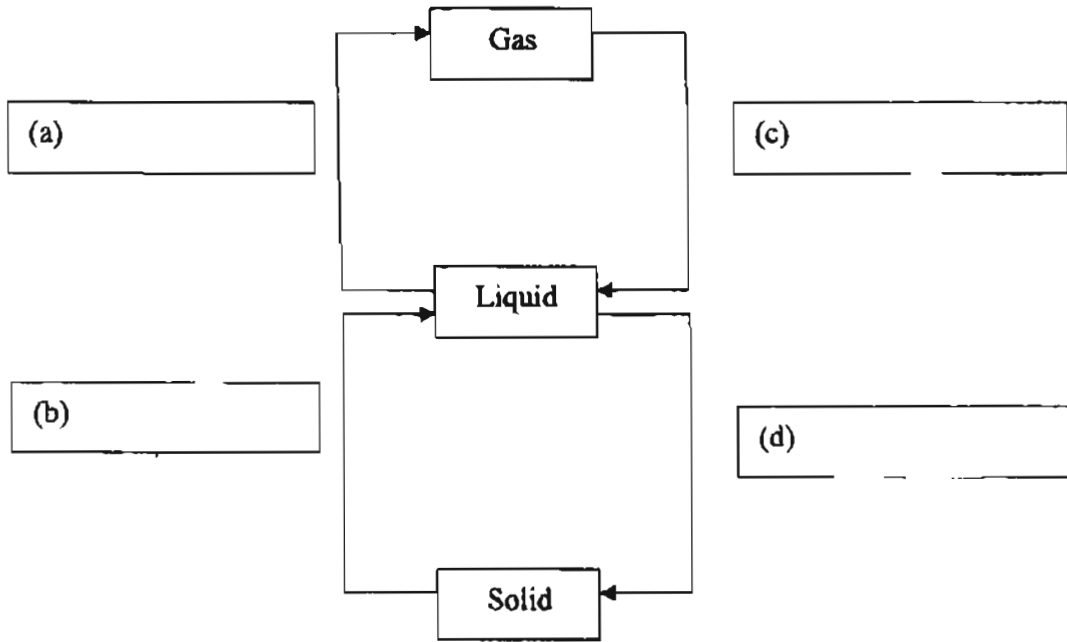

46. The diagram below shows four bulbs, K, L, M and N connected to two batteries.

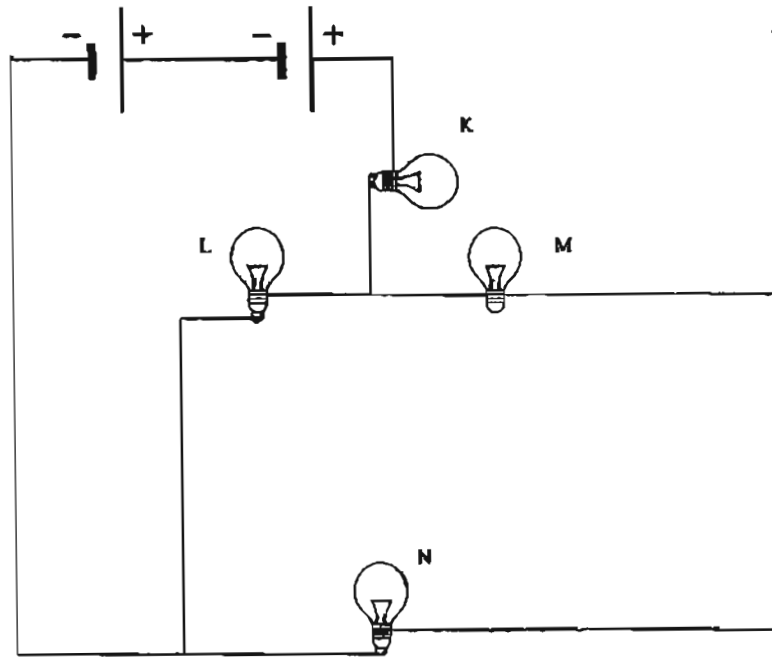

a. What will happen to the other three bulbs when bulb M fuses? (1 m)

---

---

b. Explain your answer in (a). (1 m)

---

---

c. Draw the symbol of the light bulb in the box below. (1 m)

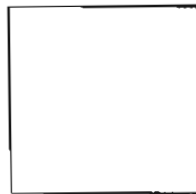

\*\*\*\*\*End of Paper\*\*\*\*\*



37) a) It swallows the water and the water passes through the gills and the gills takes in dissolved oxygen and give out carbon dioxide which flow out with the water.

b)



38) a) Smoke coming out from the factories

It causes breathing problems and affects our respiratory system.

b) Chemical waste coming out from the factories.

It pollutes the water and aquatic organisms living in the water would die.

39) a)



b) The shadow became smaller and clearer.

The shadow of the cardboard is bigger and blurier.

40) a) (i) D

b) waxing crescent c) 3

41) C

42) a) anti-clockwise

A

b) clockwise

C

E

c) 4

43) a) water

b) The rate of decrease in temperature is slower.

c) The same type of thermometer to measure the temperature.

44) a) She would measure the distance of the block from the bottom of the ramp after it has slid down the ramp and came to a stop.

b) She should conduct the experiment a few times.

45) a) evaporation

c) condensation

b) melting

d) freezing

46) a) They would still be lighted.

b) The metal casing of bulb M is a conductor of electricity thus allowing electricity to pass through.

c)



66  
END!

- THE END -  
66