



**PRIMARY 6 MID-YEAR EXAMINATION 2016**

Name : \_\_\_\_\_ ( )

Date: 12 May 2016

Class : Primary 6 ( )

Time: 1 hour 45 minutes

Parent's Signature : \_\_\_\_\_

Marks: \_\_\_\_\_ / 60

**SCIENCE  
BOOKLET A**

**INSTRUCTIONS TO CANDIDATES**

Write your name, class and register number.

Do not turn over this page until you are told to do so.

Follow all instructions carefully.

Answer all questions.

**Section A (30 x 2 marks)**

For each question from 1 to 30, four options are given. One of them is the correct answer. Make your choice (1, 2, 3 or 4). Shade the correct oval (1, 2, 3 or 4) on the Optical Answer Sheet (OAS) provided.

1. Which of the following energy pyramids correctly shows a balance in the food chain below?

A → B → C → D

(1)

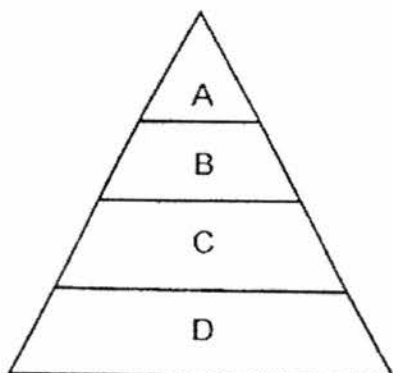

(2)

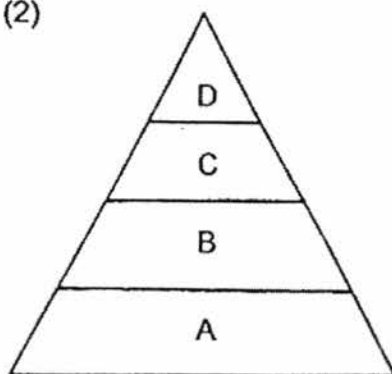

(3)

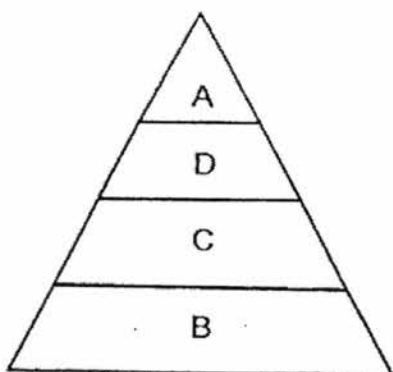

(4)

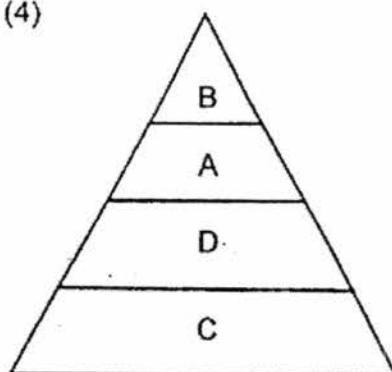

2. Kumar conducted two experiments on food relationships in a community consisting of a plant and three other organisms, A, B and C.

The table below shows the observations at the end of the experiments after three days.

Experiment	Start of experiment	End of experiment
1	<ul style="list-style-type: none"> <li>• Five freshly plucked leaves from the plant</li> <li>• One living organism A</li> <li>• One living organism C</li> </ul>	<ul style="list-style-type: none"> <li>• Bits of leaves</li> <li>• One living organism C</li> </ul>
2	<ul style="list-style-type: none"> <li>• One living organism A</li> <li>• One living organism B</li> <li>• One living organism C</li> </ul>	<ul style="list-style-type: none"> <li>• One living organism B</li> </ul>

Based on the experiments above, which of the following shows a possible food relationship amongst the plant and the organisms, A, B and C?

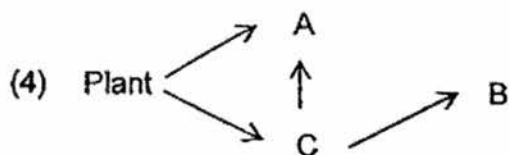
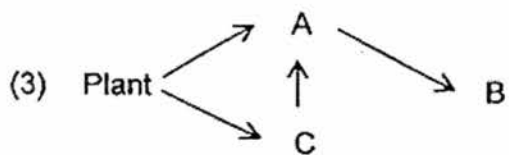
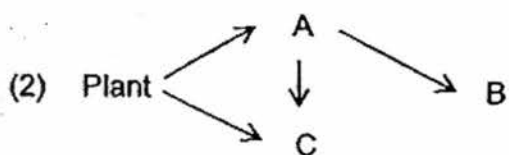
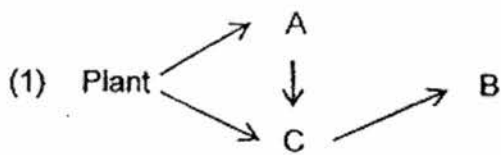

3. The food web below shows the food relationships between organisms, A, B, C, D, E, F, G and H.

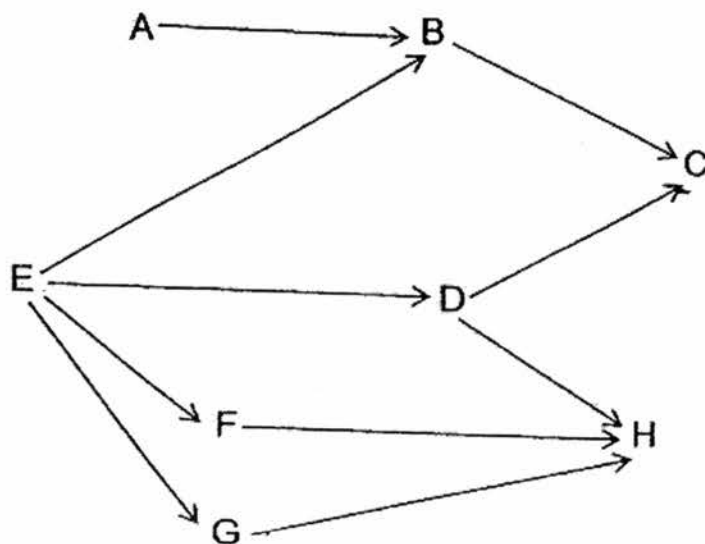

Which of the following statements is true of the food web?

- (1) The only source of food for H is D.
- (2) There are ~~three~~<sup>4</sup> plant-eaters in the food web.
- (3) ~~All~~ of the organisms in the food web feed on E.
- (4) None of the organisms present in the food web is a plant-and-animal eater.

4. The diagram below shows the flow of energy between organisms, A, B, C and D, in an ecosystem.

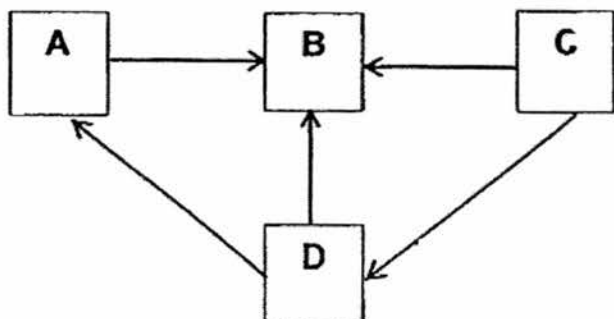

Which of the following correctly represents the role that organisms, A, B, C and D, play in the food web?

	A	B	C	D
(1)	Consumer	Consumer	Decomposer	Producer
(2)	Consumer	Decomposer	Producer	Consumer
(3)	Consumer	Decomposer	Consumer	Producer
(4)	Consumer	Consumer	Producer	Decomposer

5. The desert cottontail is a type of rabbit that lives in a desert. The two line graphs below show the relationship between the activity level of the desert cottontail and the temperature changes of the desert in a day.

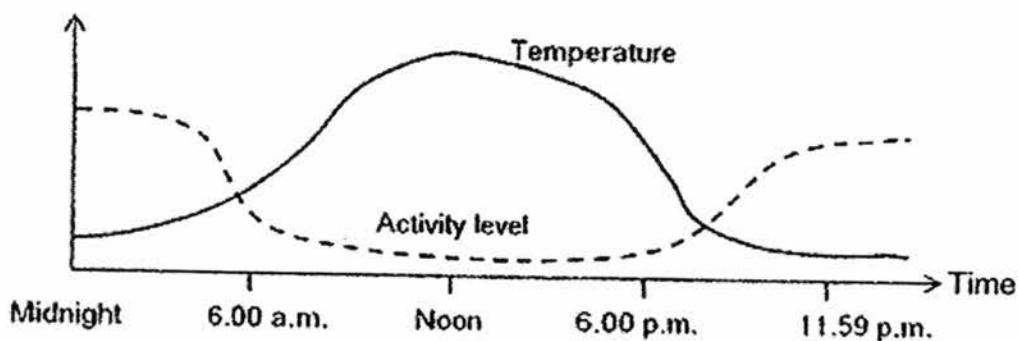

Which of the following conclusions can you make about the desert cottontail based on the graphs?

- A: Its fur colour helps it to survive in a desert.
- B: It is able to survive in a desert because it hibernates.
- C: Its behavioural adaptation helps it to survive in the desert.
- D: Its activity level increases when the temperature decreases.

- (1) A and C only
- (2) B and D only
- (3) A and D only
- (4) C and D only

6. Tom saw Animal X in his room and he tried to catch it by its tail. However, its tail broke off and Animal X managed to escape.



Which of the following shows the breaking of its tail help Animal X increase its chances of survival?

- (1) It helps to keep Animal X warmer.
  - (2) It helps Animal X to distract its predator.
  - (3) It allows Animal X to blend into the surroundings.
  - (4) It enables Animal X to crawl in to cracks and gaps.
7. The diagrams below show the life cycles of two insects.

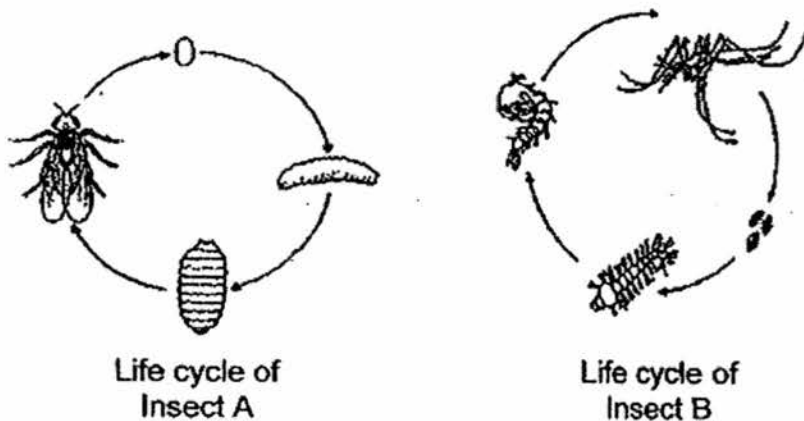

Based on what you can observe from the life cycles above, which of the following best describes a similarity of the young of both insects?

- (1) They look like their parents.
- (2) They go through the pupal stage.
- (3) They have more legs than their parents.
- (4) They live in the same habitat as their parents.

8. The diagram below shows a seed growing into a young plant.

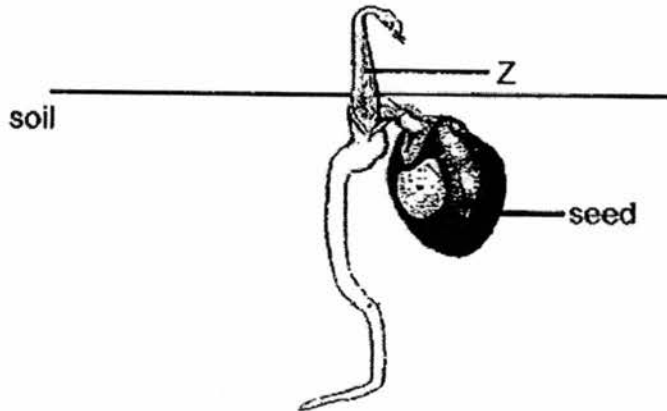

Which of the following shows the direction in which food and water are being transported at Z?

Direction of transport of	
food	water
(1) upwards	upwards
(2) downwards	upwards
(3) upwards	downwards
(4) downwards	downwards



9. A group of Primary 6 pupils counted the number of plants and animals in the school pond. They drew a bar chart based on their data collected as shown below.

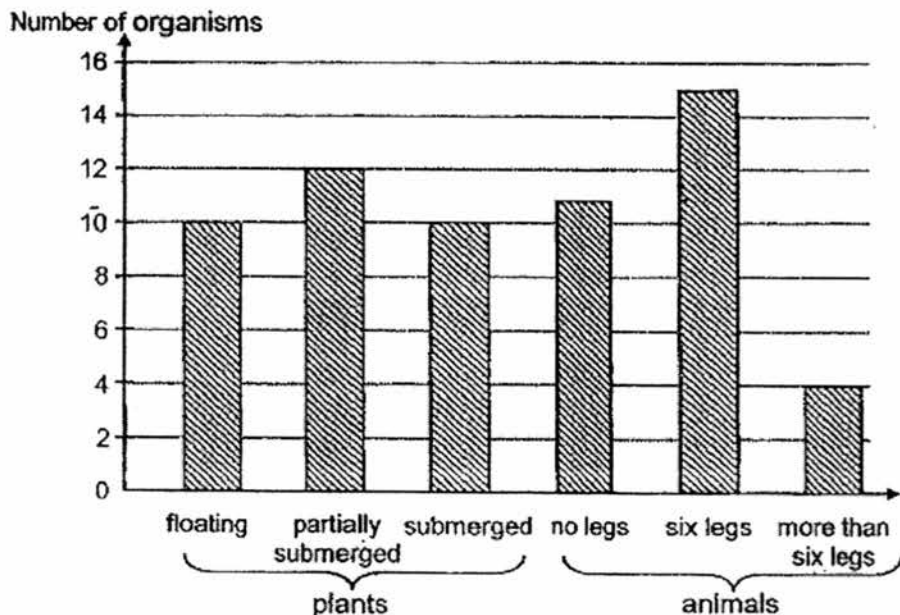

Which of the following statements about the plants and the animals in the pond is/ are correct?

- A: There are 30 populations of animals.  
 B: There is at least 6 populations of plants and animals.  
 C: The number of floating plants and submerged plants are equal.

- (1) A only  
 (2) A and C only  
 (3) B and C only  
 (4) A, B and C

10. Jenny has a garden where she planted some vegetables and fruit trees. She always buries leftover food and bones in the garden instead of throwing them in dustbins. Why does Jenny bury these items?

- (1) They will not be broken down easily.  
 (2) They will decompose only if they are buried.  
 (3) They will attract mosquitoes if they are not buried.  
 (4) They will decompose and provide nutrients for the plants.

11. Study the food web below.

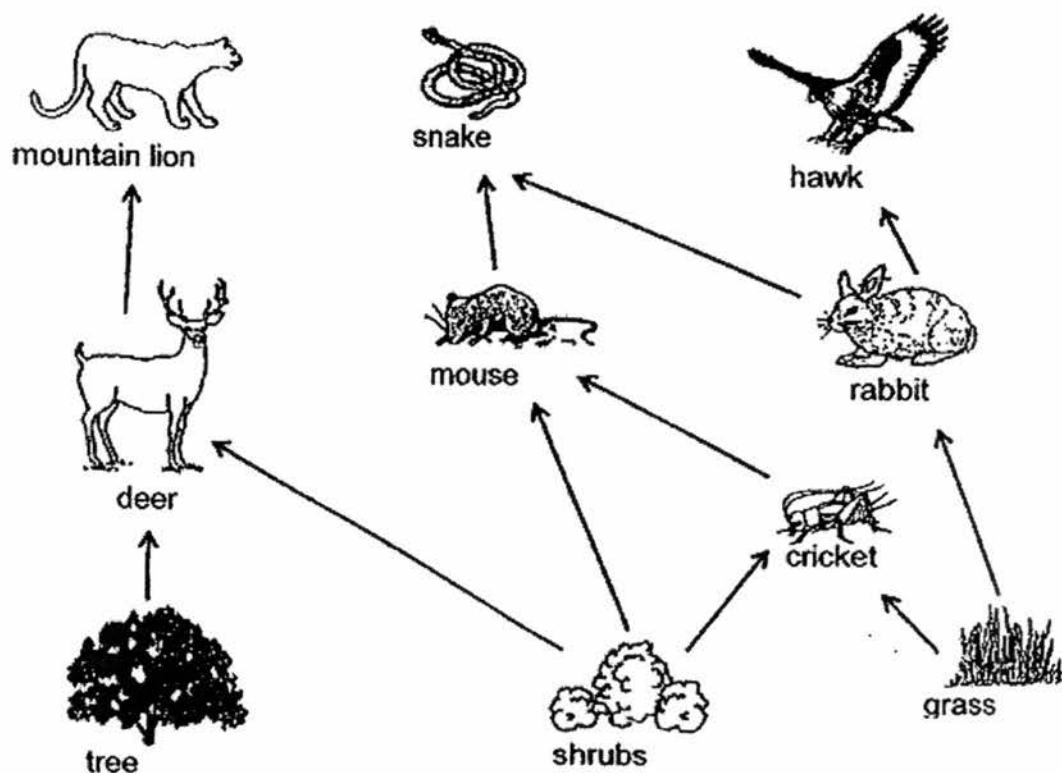

Which of the following statements are definitely true about the food web above?

- A: There are three types of food producers in the web.
- B: When the population of snakes decreases, the population of the crickets would increase.
- C: The population of the deer is only affected by the population of the mountain lion.
- D: When the populations of all the plants decrease, the populations of other organisms would decrease too.

- (1) A and D only
- (2) B and C only
- (3) A, C and D only
- (4) A, B, C and D

12. The diagram below shows three birds, X, Y and Z, which feed on fish.

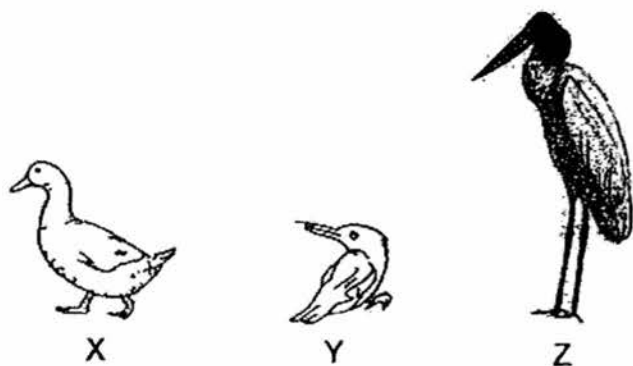

They are usually seen in different parts, D, E and F of the habitat below.

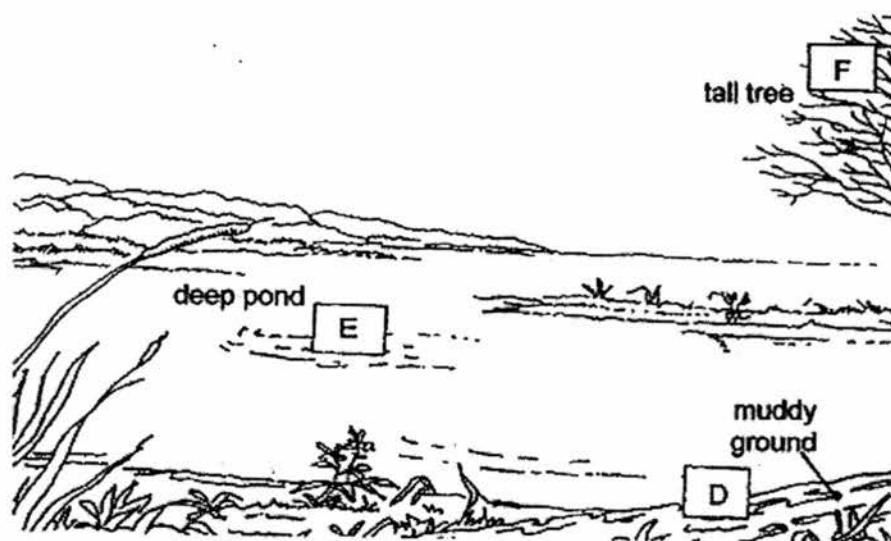

Which of the birds, X, Y and Z, are most likely to be found at D, E and F?

	D	E	F
(1)	X	Y	Z
(2)	Y	Z	X
(3)	Z	X	Y
(4)	Y	X	Z

The picture below shows the fruit of the Rose of India.

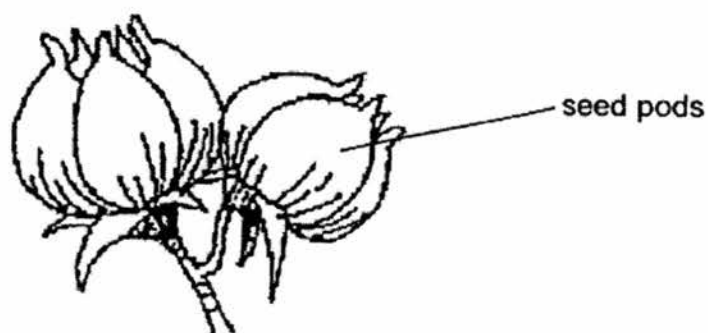

fruit of Rose of India

The fruits have seed pods which are hard and dry when matured and the seeds have wing-like structures.

How does the Rose of India disperse its seeds?

- A: By wind
- B: By splitting
- C: By animals

- (1) A only
- (2) B only
- (3) A and B only
- (4) A and C only

14. Which of the following diagrams below correctly shows the movement of blood in the human circulatory system?

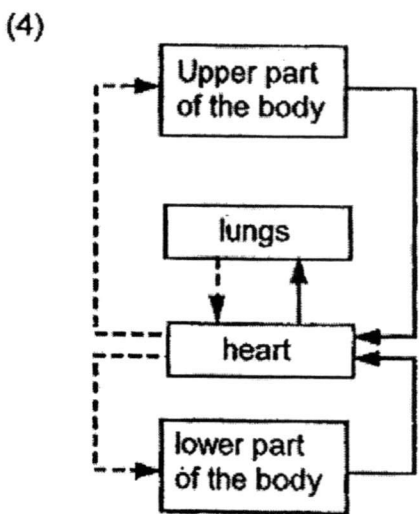
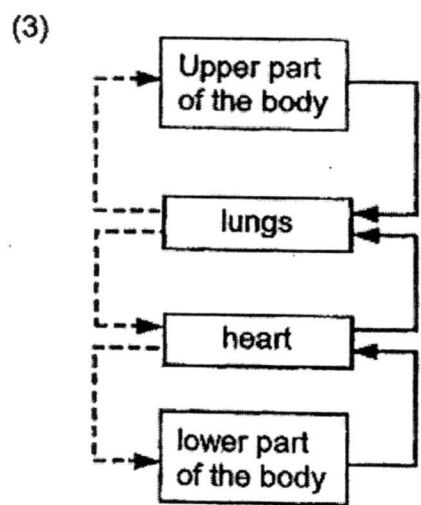
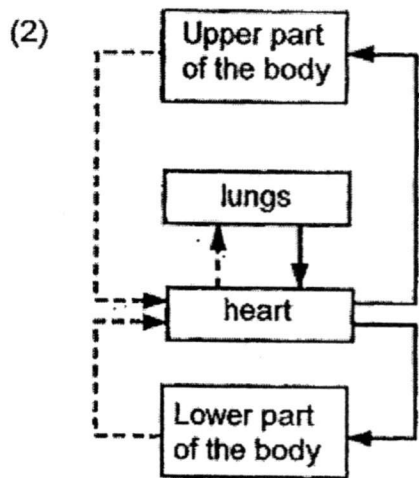
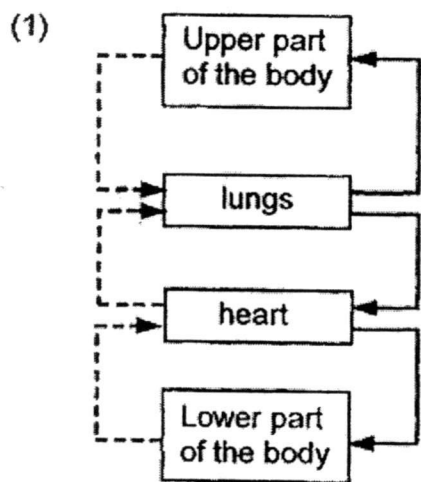
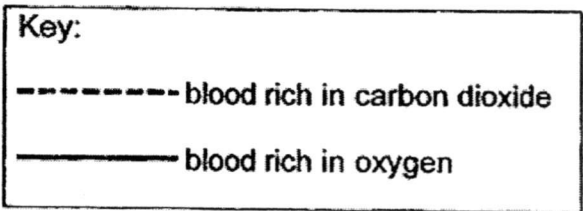

15. Shanti carried out an experiment with the following steps to show out how plants grow under certain conditions.

Step 1: She filled two identical flower pots with the same amount of garden soil.

Step 2: She labelled each pot, Pot A and Pot B, respectively.

Step 3: She planted the same number of the same type of seed in each pot.

Step 4: She placed Pot A in the garden and Pot B in a closed cupboard.

Step 5: She watered each pot with the same amount of water daily.

Which of the following was Shanti trying to show?

- (1) Water is necessary for healthy plant growth.
  - (2) Space is necessary for healthy plant growth.
  - (3) Sunlight is necessary for healthy plant growth.
  - (4) Garden soil is necessary for healthy plant growth.
16. The picture below shows a solar panel on the roof of a house. The solar panel is connected to the water heater.

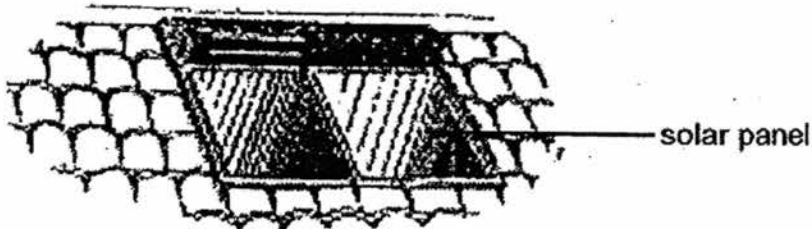

Which of the following shows the energy conversion taking place in a solar-powered water heater?

- (1) light energy  $\rightarrow$  electrical energy  $\rightarrow$  heat energy
- (2) heat energy  $\rightarrow$  electrical energy  $\rightarrow$  heat energy
- (3) light energy  $\rightarrow$  chemical potential energy  $\rightarrow$  heat energy
- (4) chemical potential energy  $\rightarrow$  kinetic energy  $\rightarrow$  heat energy

17. A marble was placed at the top of a curved slope as shown below.

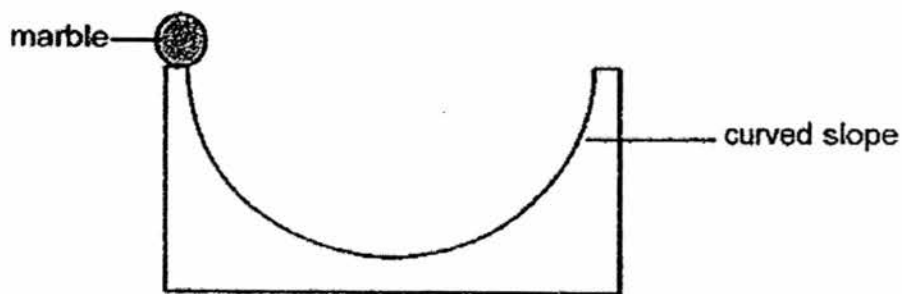

The graph below shows the changes in kinetic energy of the marble once it was released.

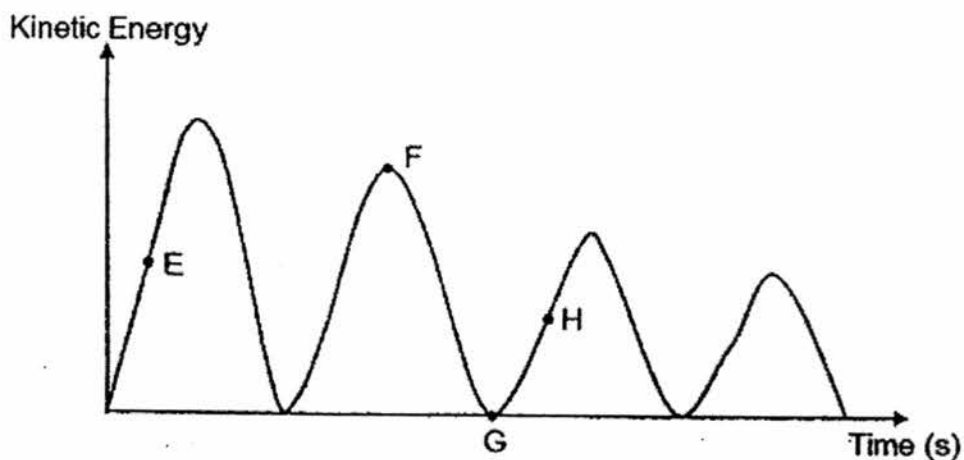

Which of the following letters, E, F, G or H, in the graph represents the point where the marble was at the bottom of the slope?

- (1) E
- (2) F
- (3) G
- (4) H

18. The flowchart below is used to classify three different types of forces, A, B and C.

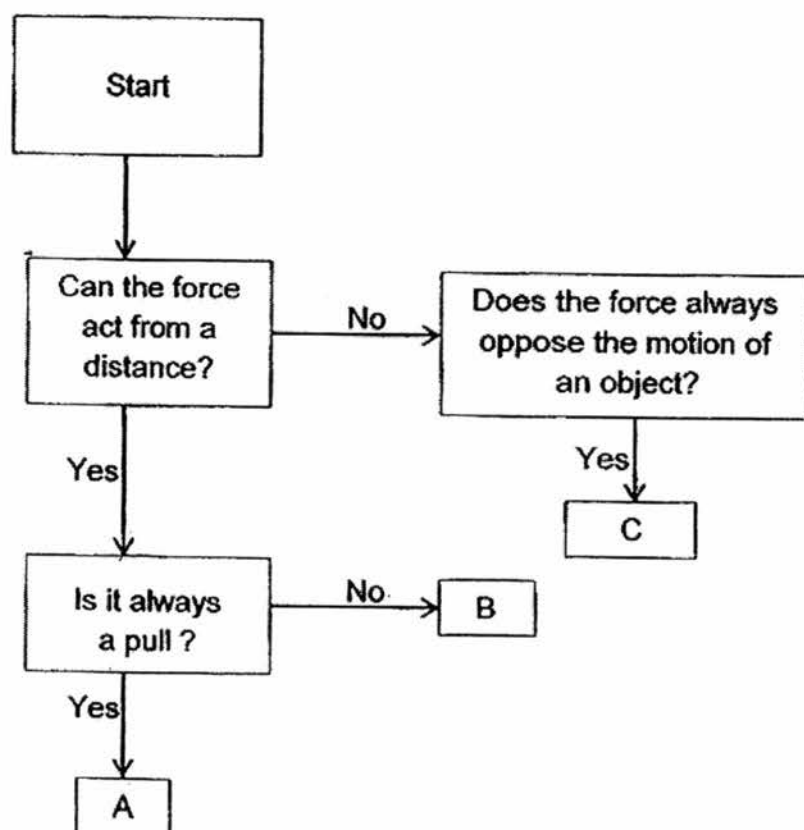

Which of the following are the forces, A, B and C?

	A	B	C
(1)	Gravitational	Magnetic	Frictional
(2)	Magnetic	Gravitational	Frictional
(3)	Magnetic	Gravitational	Elastic Spring
(4)	Gravitational	Magnetic	Elastic Spring



19. Simone had four rods, P, Q, R and S, of unknown materials. She connected the rods in the circuit below. All the bulbs were connected correctly and were working properly.

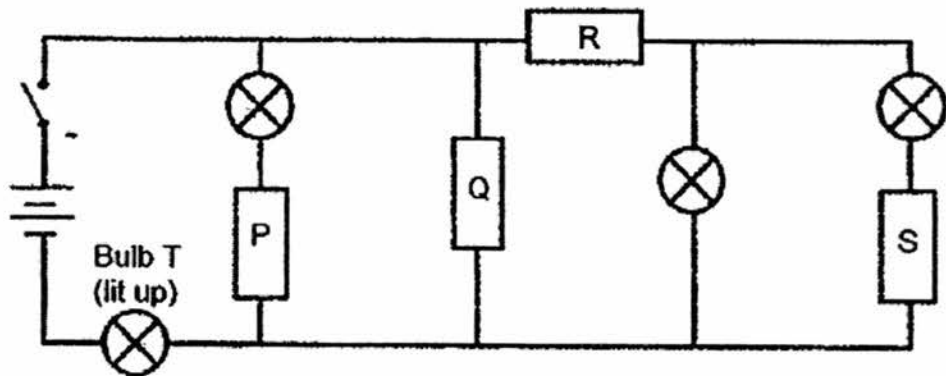

She observed that only Bulb T lit up when the circuit was closed.  
Which of the following correctly describes the electrical conductivity of the rods, P, Q, R and S?

Does it conduct electricity?				
	P	Q	R	S
(1)	No	Unable to tell	Yes	No
(2)	No	Yes	Yes	No
(3)	Yes	No	No	Unable to tell
(4)	No	Yes	No	Unable to tell

20. The diagram below shows two shapes, P and Q, made of cardboard.

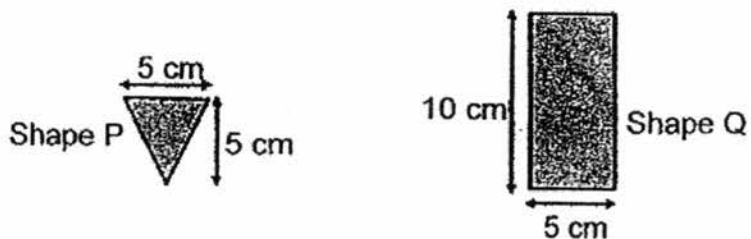

The two shapes are placed between a torch and a screen as shown below.

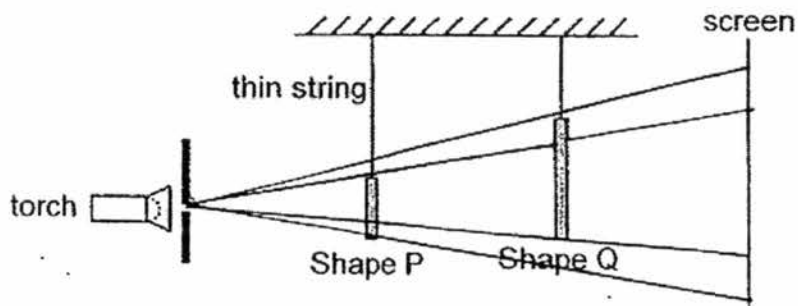

Which of the following shows the shadow formed on the screen when the torch is switched on?

(1)



(2)



(3)

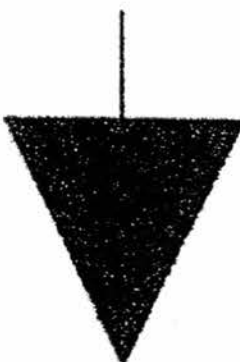

(4)



21. Caroline found four bars, W, X, Y and Z, made of different materials. She carried out a scratch test to investigate the hardness of the four bars. The table below shows the results of the test performed on the four bars.

Results of Test			
Bars	Presence of scratch marks made by the disc?		
	Iron disc	Wooden disc	Plastic disc
W	No	No	No
X	Yes	No	No
Y	Yes	Yes	Yes
Z	Yes	Yes	No

Based on the test results above, arrange the bars from the **least hard to the hardest**.

- (1) W, X, Z, Y
- (2) Z, Y, X, W
- (3) Y, Z, X, W
- (4) Y, Z, W, X

22. The diagram below shows a ball rolling down a slope from point A and stopping at point D.

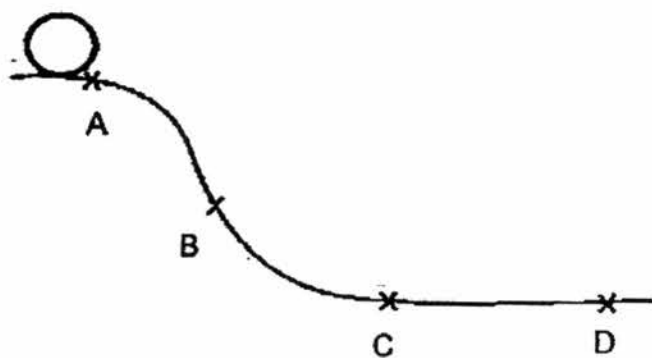

Which of the following graphs shows the change in the amount of the gravitational potential energy and kinetic energy of the ball from point A to point D?

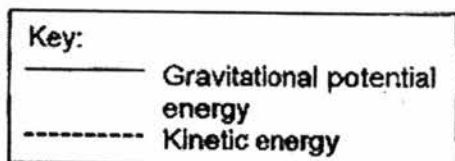

(1)

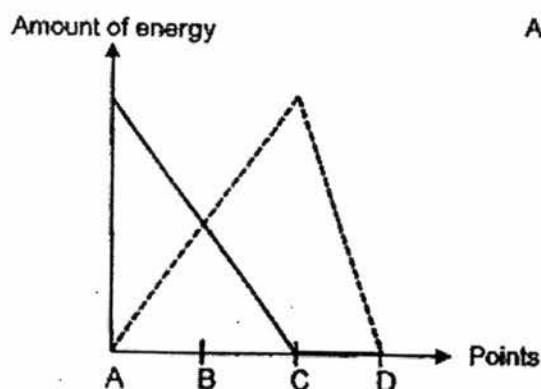

(2)

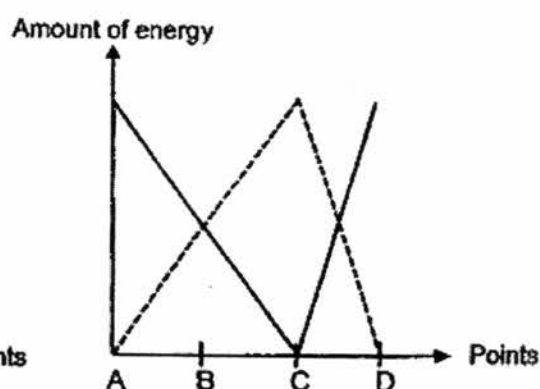

(3)

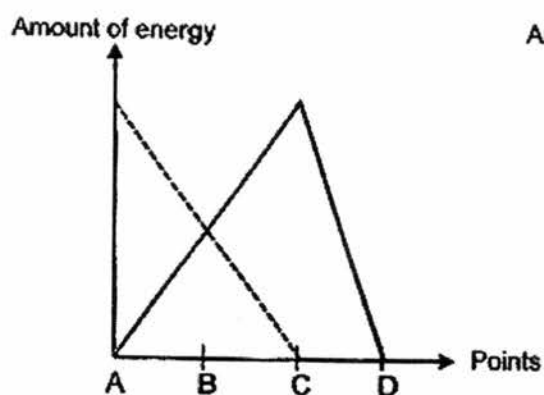

(4)

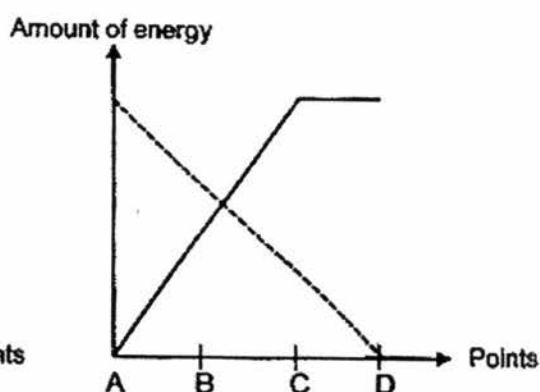

23. Three similar bottles, W, X and Y, were filled to the brim with water. The bottles were tilted at the same angle but held at different heights above an empty metal box as shown below.

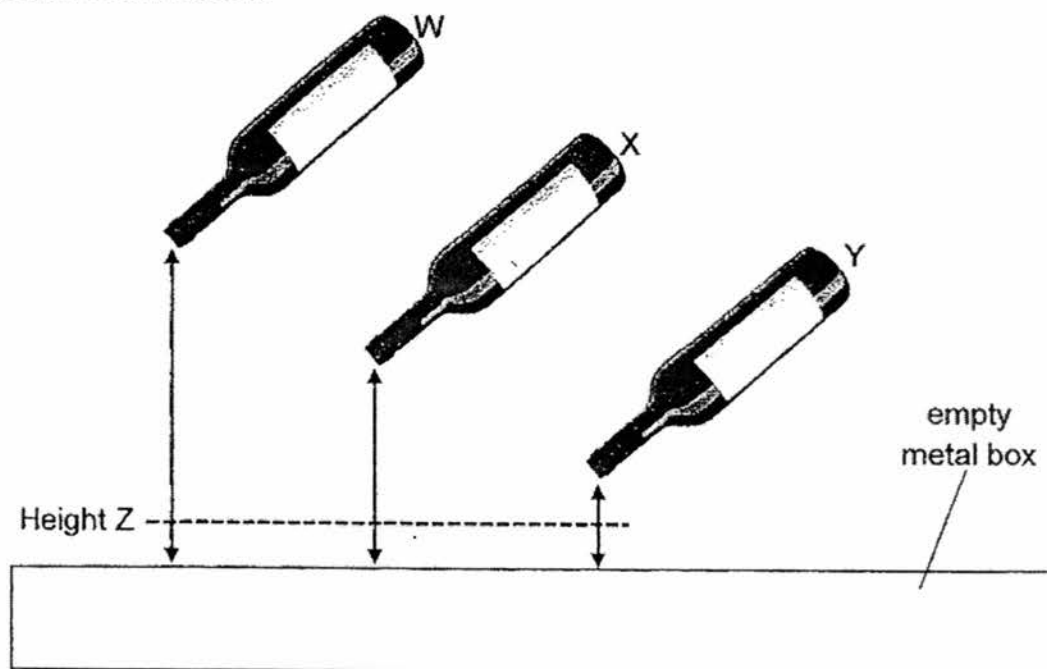

Which of the following statements are true about the above experiment?

- A: Water flowed out of the bottles, W, X and Y, at the same rate.
- B: Water from the bottle, W, produced the loudest sound upon hitting the metal box.
- C: Water from the bottles, W, X and Y, possessed the same amount of kinetic energy at height Z.
- D: Water flowing out from the bottles, W, X and Y, possessed gravitational potential energy and kinetic energy when the bottles were tilted.

- (1) A and D only
- (2) B and C only
- (3) B, C and D only
- (4) A, B and D only.

24. Yvette conducted an experiment on Spring A and Spring B. She hung various loads one at a time on the springs and recorded the resulting length of the spring. Her results are shown in the graph below.

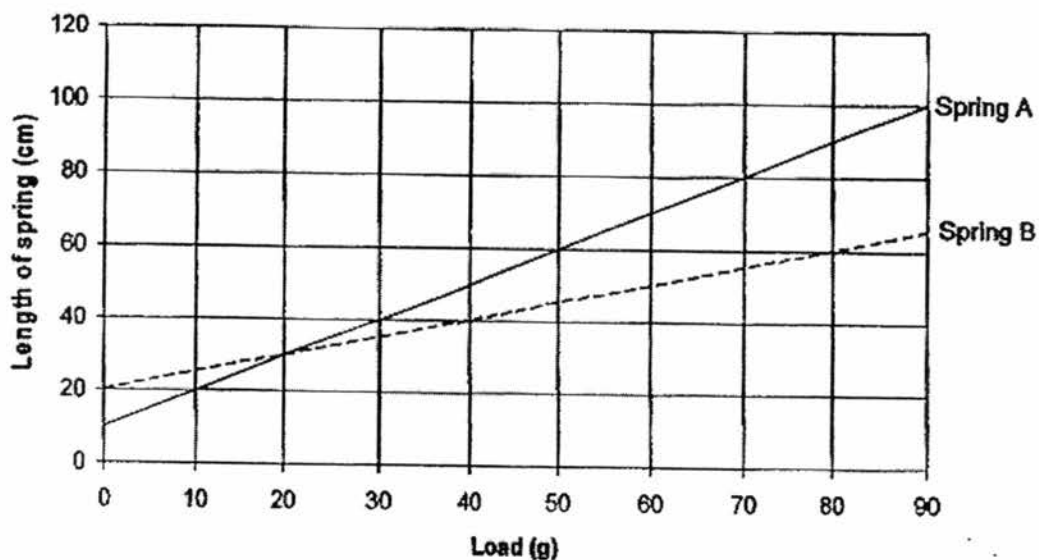

Based on the graph, what can Yvette conclude about the springs?

- A: The original length of Spring A is shorter than the original length of Spring B.
  - B: For the same load hung on the springs, Spring A extends more than Spring B.
  - C: Gravity acts on the mass hung on the springs but not on the springs.
- (1) C only  
(2) A and B only  
(3) B and C only  
(4) A, B and C

25. A toy truck, at point X, was moving down a slope as shown below.



After some time, the toy truck stopped at point Y.

Compare the kinetic energy and the potential energy of the toy truck at point X and point Y. Which of the following is correct?

	<b>Kinetic energy at Y compared to X</b>	<b>Potential energy at Y compared to X</b>
(1)	more	more
(2)	less	more
(3)	more	less
(4)	less	less

26. Three bar magnets AB, CD and EF can be arranged as shown below.

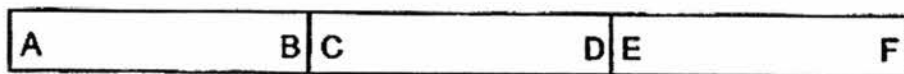

Which of the following arrangements of the magnets is possible?

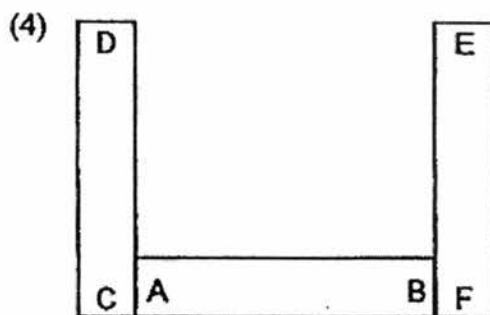
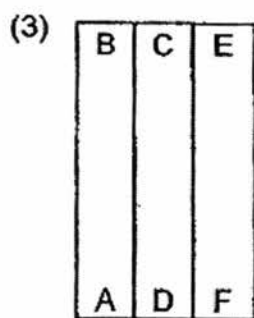
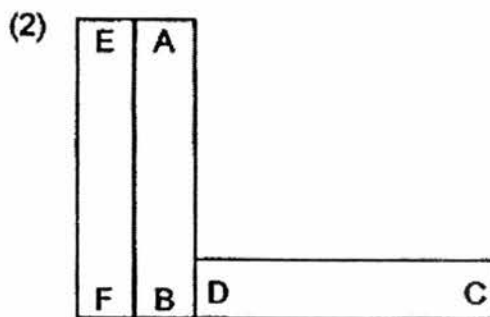
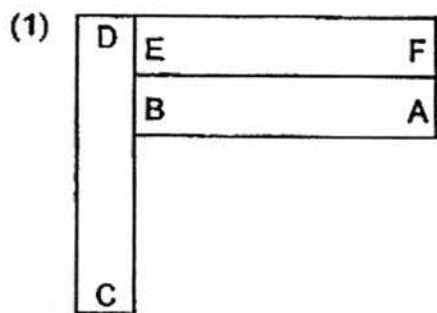



27. Block G is released from the top of a smooth slope. It moves down and hits Block K at the bottom of the slope.

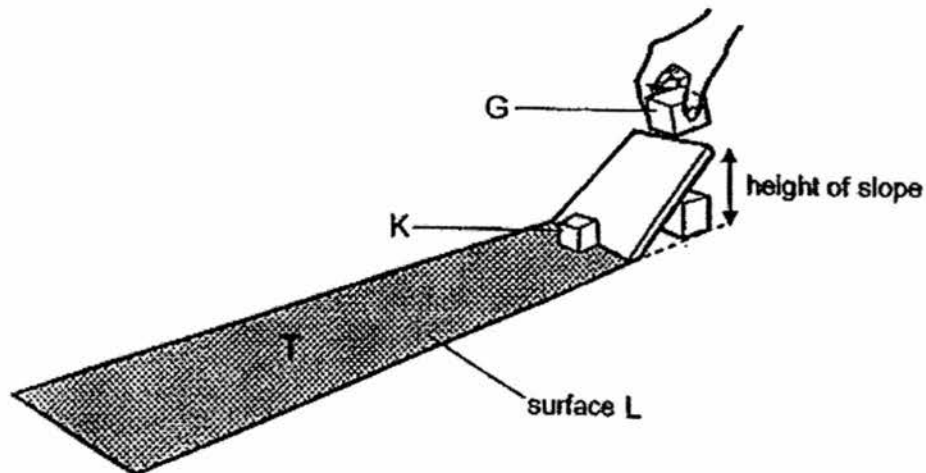

After being hit by Block G, Block K slides along Surface L, before coming to a stop at the point T.

Which of the following changes can increase the distance moved by Block K along Surface L?

- (1) increasing the width of the slope
- (2) increasing the height of the slope
- (3) increasing the length of Surface L
- (4) increasing the roughness of Surface L

28. The diagram below shows the process of obtaining sea salt from sea water. This method of producing salt is still used till this day.

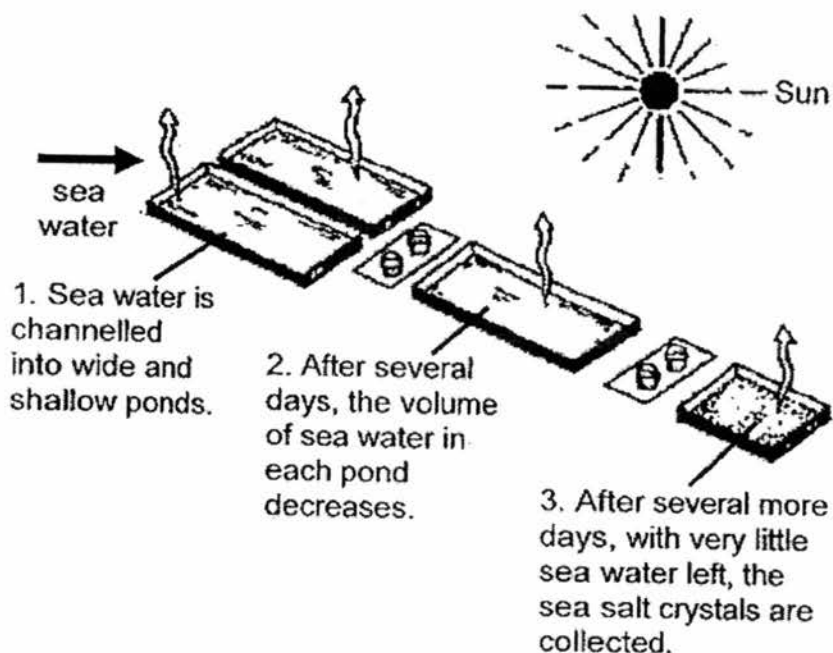

Which of the following happens during the above method of producing salt?

- (1) Heat is lost by the seawater during the evaporation process.
- (2) Heat is lost by the seawater during the condensation process.
- (3) Heat is gained by the seawater during the evaporation process.
- (4) Heat is gained by the seawater during the condensation process.

29. Gopal has four magnets, E, F, G and H, as shown below.

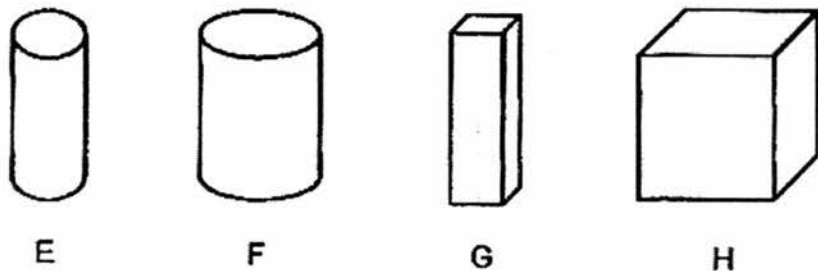

To compare the strength of the magnets, he put each of the magnets near a tray of pins. The table below shows the number of pins attracted by the magnets, E, F, G and H, from various distances.

Magnet	Distance between the magnet and the pins (cm)	Number of pins attracted
E	5	10
F	4	10
G	6	8
H	4	12

Which of the following statements is definitely correct?

- (1) H is the strongest magnet.
- (2) F is as strong a magnet as H.
- (3) E is a stronger magnet than F.
- (4) F is a stronger magnet than G.

30. Chandru was told to select the best materials for making raincoats and helmets based on the classification chart below. He was also told not to choose the same materials for making the items.

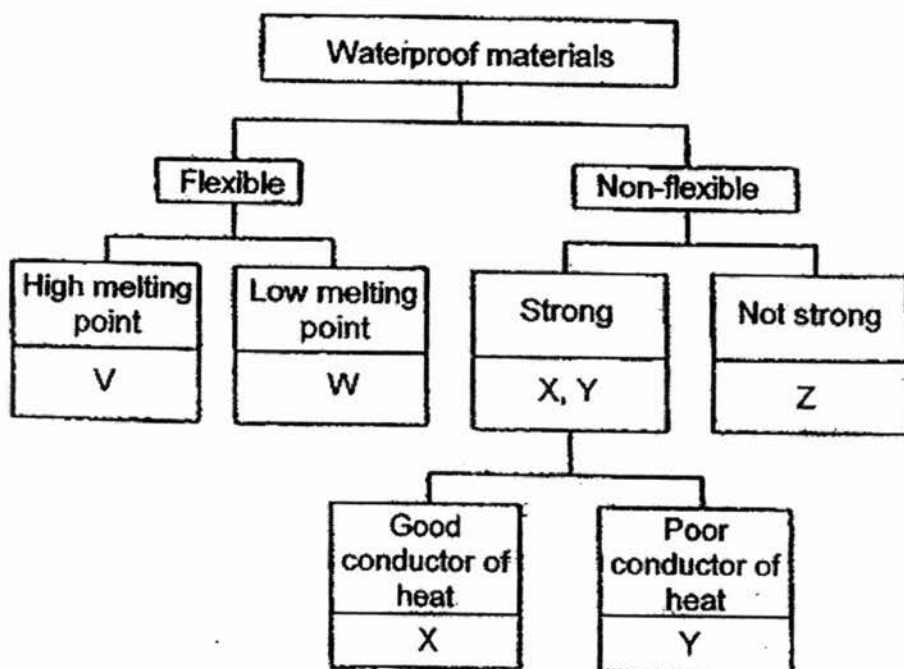

Which of the following shows the best materials for making the raincoats and helmets?

	Raincoats	Helmets
(1)	V	Z
(2)	W	Y
(3)	X	Y
(4)	V	Y

End of Booklet A



## PRIMARY 6 MID-YEAR EXAMINATION 2016

Name : \_\_\_\_\_ ( )

Date: 12 May 2016

Class : Primary 6 ( )

Duration: 1 hour 45 minutes

Parent's Signature : \_\_\_\_\_

## SCIENCE BOOKLET B

### INSTRUCTIONS TO CANDIDATES

Write your name, class and register number.

Do not turn over this page until you are told to do so.

Follow all instructions carefully.

Answer all questions.

Booklet A	60
Booklet B	40
<b>Total</b>	<b>100</b>

**Section B (40 marks)**

**Write your answers to the questions, 31 to 44, in the spaces provided.**

31. The diagrams below show two trees, A and B, with different types of roots.

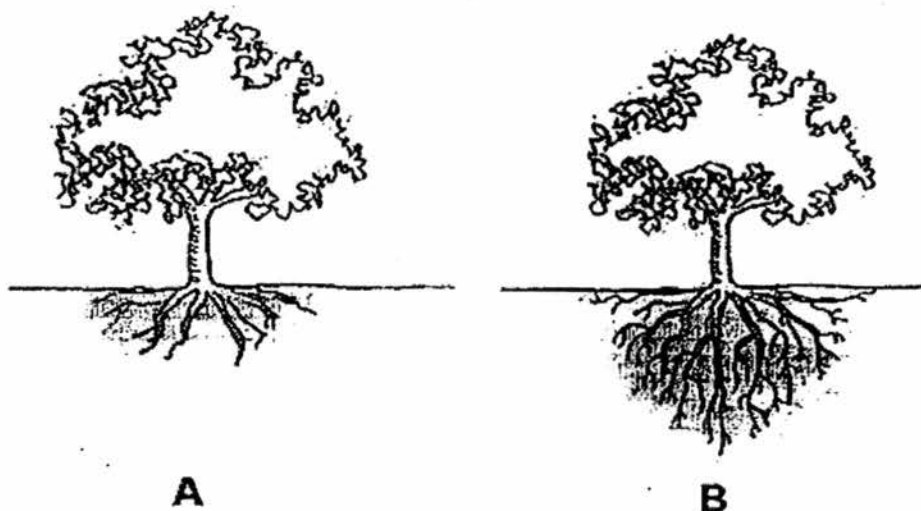

- a) Which tree is more likely to topple during a heavy storm?  
Explain your answer.

[1]

---

---

- b) State another function of the roots of the trees.

[1]

---

---

32. In the flow chart below, A, B, C and D, represent different animals.

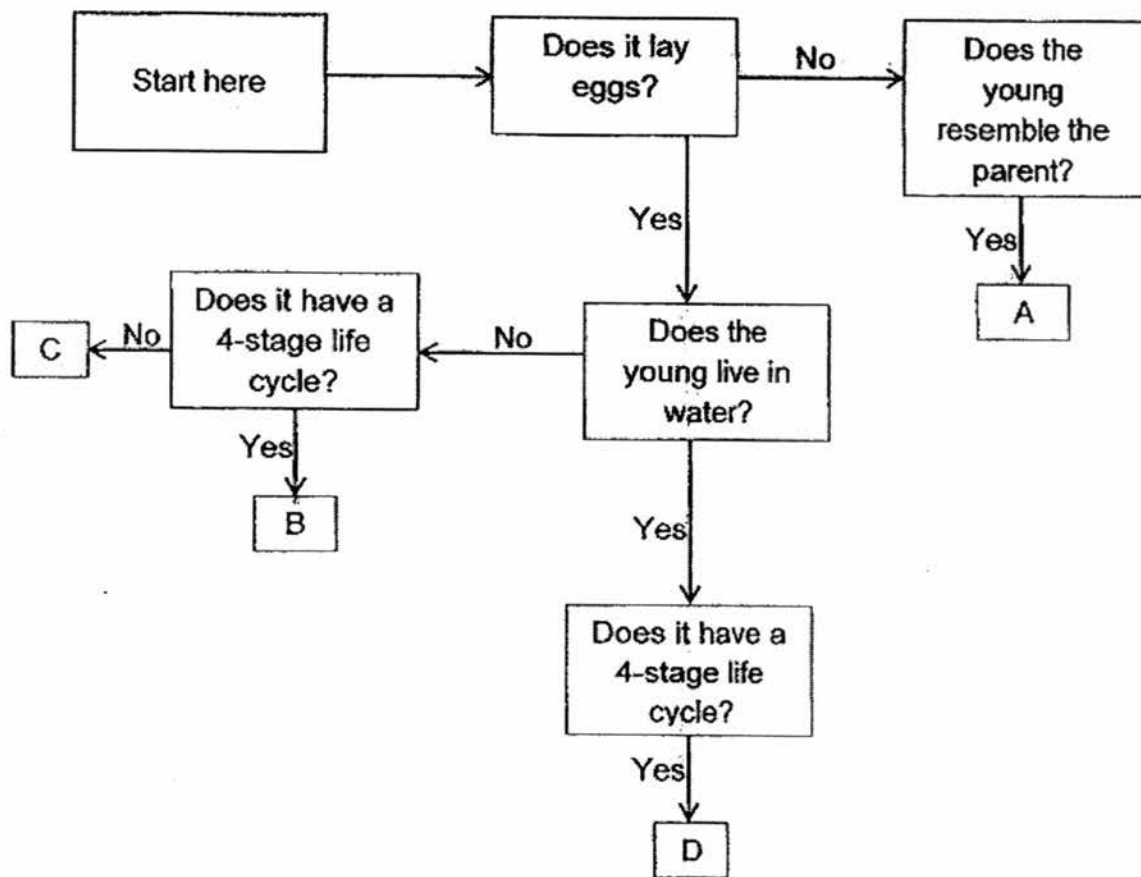

Based on the flow chart, write down the letter that represents each animal in the table below. [2]

	Animals	Letters
i)	Mosquito	
ii)	Monkey	
iii)	Housefly	
iv)	Cockroach	

33. The diagram below shows an experiment to investigate the effect of the presence of carbon dioxide on photosynthesis in a plant. The leaves of the plant were green in the centre and white around the edges. The plant had sufficient water and was placed under suitable light intensity for 48 hours.

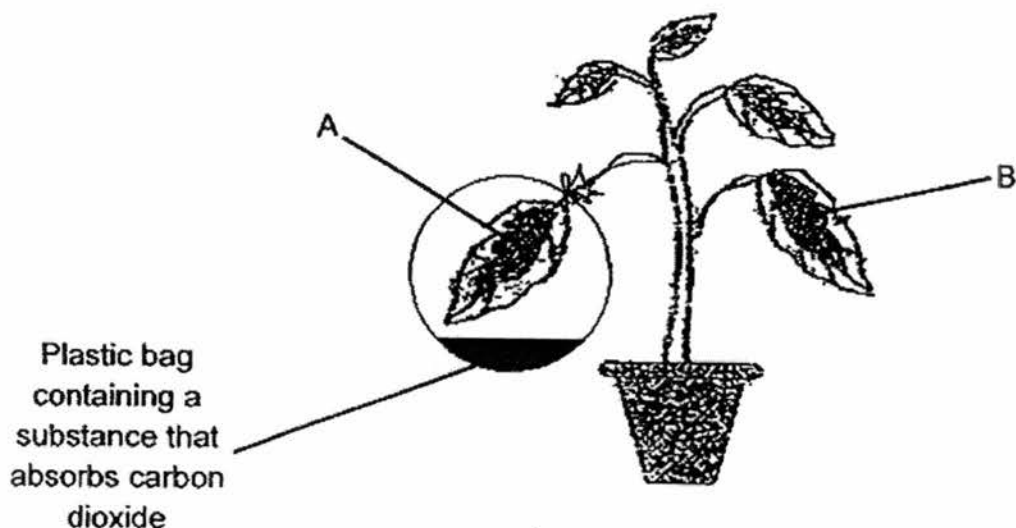

- a) The leaves, A and B, from the plant were then tested for starch with iodine solution. Complete the following table with the expected correct results for the leaves, A and B. [1]

	Leaf	Results (Colour of iodine solution on the green part of the leaf)
(i)	A	
(ii)	B	

- b) Explain your answer in part (a)(i) [2]

---



---



34. Daniel collected water from 4 different ponds to grow duckweeds. He poured 100 ml of water from each pond into four similar beakers, A, B, C and D. He then added twenty duckweeds into each beaker and left the beakers near a window.

At the end of each week, he counted the number of duckweeds in each beaker and recorded his observations in the graph below.

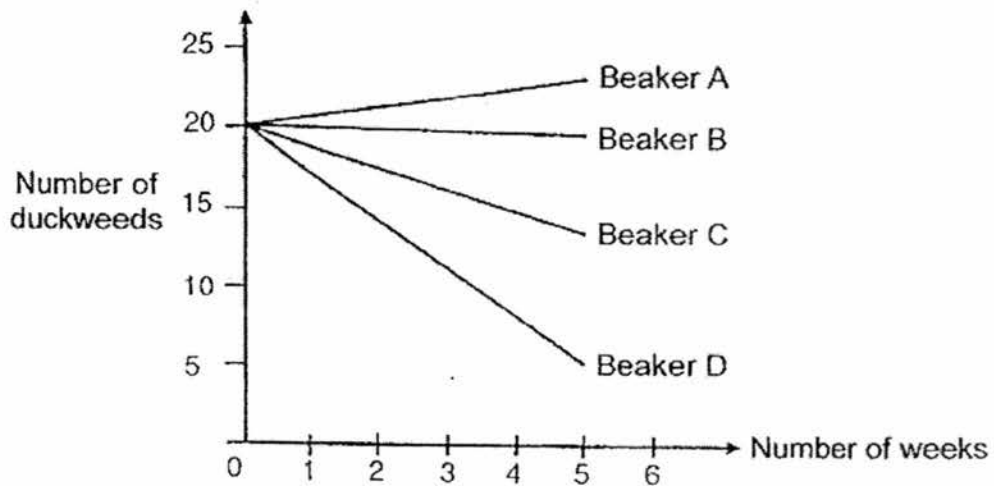

a) Which beaker of water, A, B, C or D, is the most suitable for the growth of duckweeds? Give a reason for your answer. [1]

---

---

b) After a few weeks, Daniel returned to the pond where the water in Beaker A was taken from. He observed that the duckweeds covered almost the whole surface of the pond and dead fish were floating on the pond.

Explain Daniel's observation. [2]

---

---

---

---

---

35. Below shows a food web in a field community.

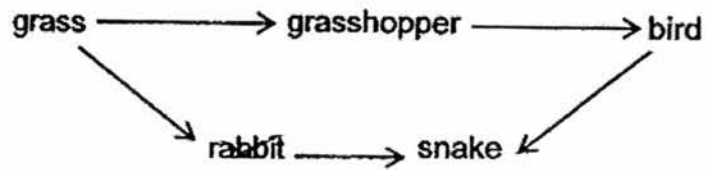

a) Which animal(s) is/ are both prey and predator? [1]

---

b) What will happen to the bird population when the entire rabbit population is killed by a disease? [2]

---

---

---

---

36. Cindy carried out an experiment on a plant. She removed a 1-cm thick outer ring from the plant at A. She also removed another ring which was 2-cm thick from the same plant at B.

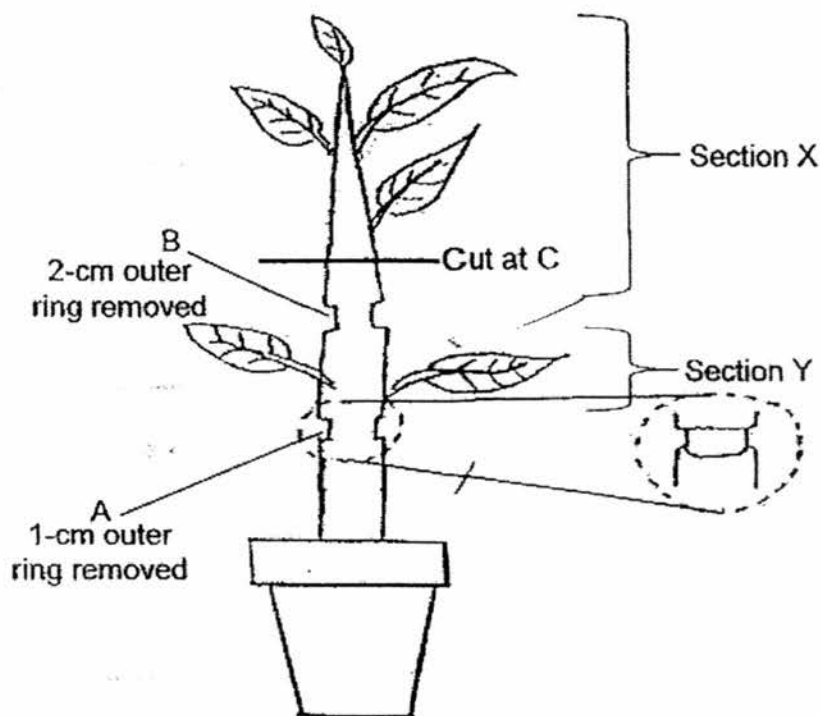

- a) After five days, Cindy noticed that Section X of the plant died while Section Y of the plant survived. Suggest the possible reasons why this happened. [2]

**Section X:**

---

---

**Section Y:**

---

---

Cindy cut the plant at C. The diagram below shows the cross-section of the stem at C.

- b) Write **'water-carrying tubes'** and **'food-carrying tubes'** in the correct boxes below to indicate the position of the tubes. [1]

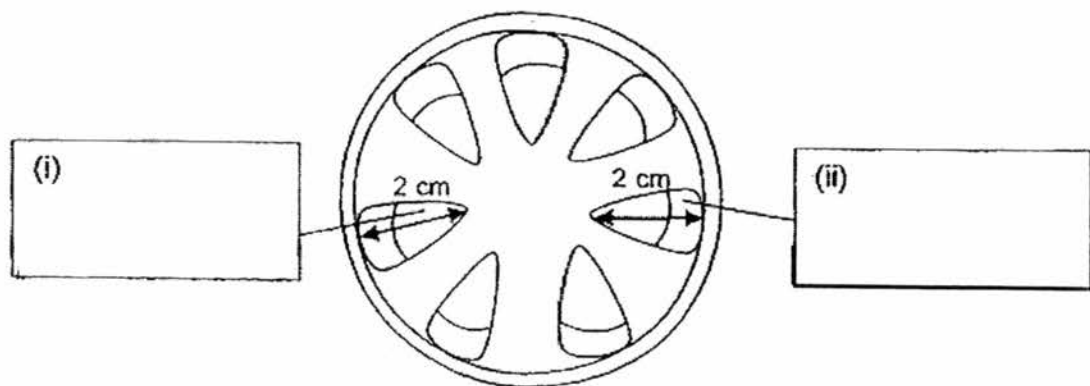

**Cross-section of stem at Part C**

37. Organism X can be found in the sea. It has a soft and flexible abdomen and no shell of its own. It will look for an abandoned shell of organism Y and will carry the shell on its back.

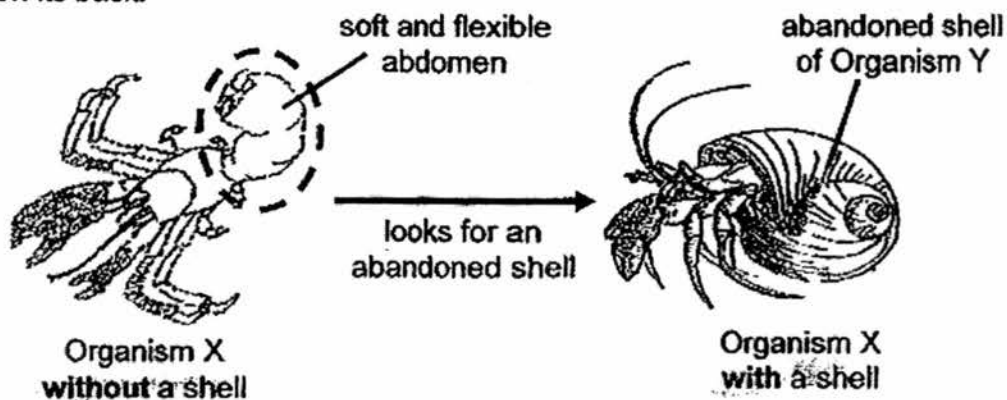

- a) Explain how the behaviour of Organism X helps in its survival. [1]

---

---

It was observed that Organism X sometimes carries other organisms such as Organism Z, on its shell. Organism Z moves very slowly from place to place on its own and its tentacles are poisonous.

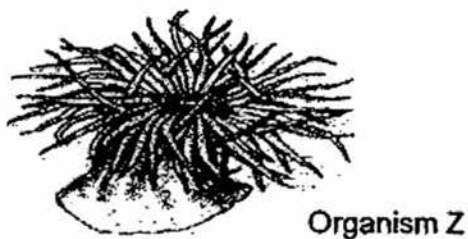

- b) Organisms X and Z are interdependent on each other for their survival. [2]

- i. How does Organism X benefit from Organism Z?

---

---

- ii. How does Organism Z benefit from Organism X?

---

---

38. Tracy carried out an experiment with three balls of different materials in the set-up shown below. The balls, A, B and C, were heated to the same temperature and then placed into three separate and identical beakers. The temperature of the water was measured regularly. The three balls were of the same shape and size.

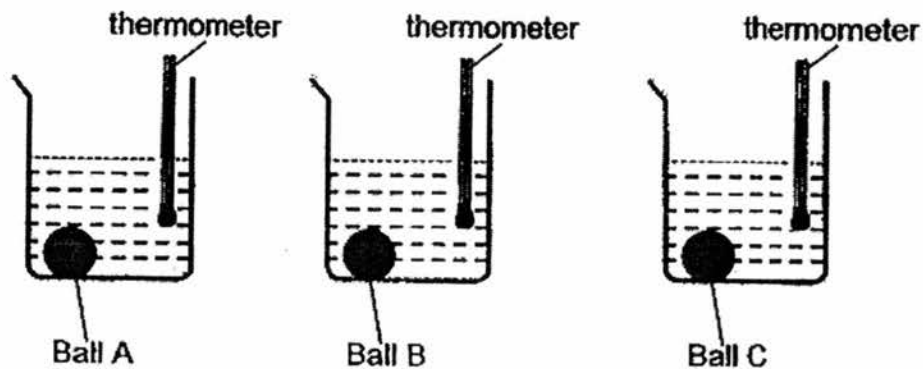

Time (min)	Temperature of water ( $^{\circ}\text{C}$ )		
	with Ball A	with Ball B	with Ball C
0	20	20	20
3	20	34	29
6	21	41	31
9	21	50	32
12	21	55	33
15	22	57	33

- a) What is the aim of the experiment? [1]
- 
- b) What other two variables must be kept constant to ensure a fair test? [2]
- 
- c) Tracy wanted to select a material to make a lunch box to keep her food warm for the **longest** time. Which material, of balls, A, B, or C, is most suitable for making this lunch box? Explain why. [1]
-

39. Michael hung a steel ball from a string at the edge of the table shown below.

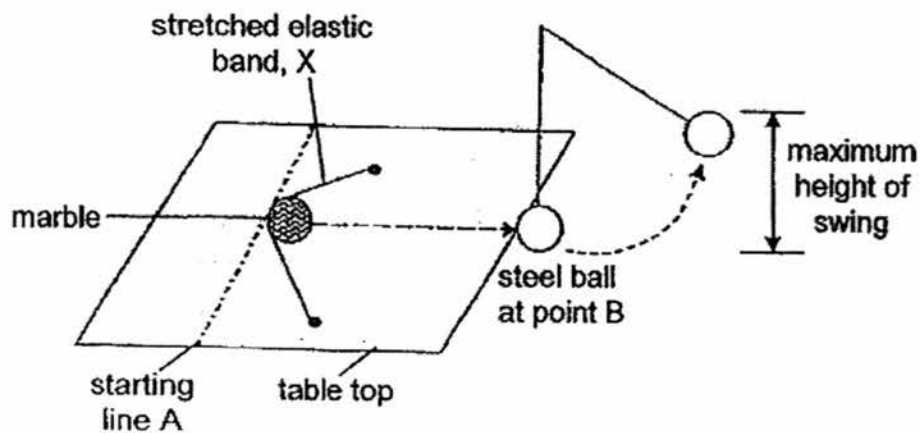

He stretched an elastic band, X, with a marble placed against it. He released the stretched elastic band. The marble hit the steel ball, causing the steel ball to swing upwards.

Michael repeated the experiment with two other types of elastic bands, Y and Z, one at a time. He recorded the maximum height of swing of the steel ball when it swung upwards away from the edge of the table. He presented his results in table below.

Elastic Band	X	Y	Z
Maximum height of swing (cm)	12	18	9

- a) Based on the results above, which elastic band has the most elastic potential energy? Give a reason for your answer. [1]

---

---

- b) When Michael stretched the elastic band further back, the maximum height of the swing of the steel ball will be higher. Explain why. [2]

---

---

40. Siva enrolled in archery as a CCA. After his first lesson of learning the technique of handling the bow and the arrow, Siva was eager to hit the centre of the target, the bull's eye.



- (a) Name the force(s) that was/were acting on the moving arrow as it moved towards the centre of the target. [1]

---

---

Siva decided to challenge his two other teammates, Paul and Kenny, in hitting the bull's eye.

The following describes how each of them aimed their arrow at the target.

**Siva:** Aimed the arrow directly at the bull's eye before releasing.

**Paul:** Aimed the arrow slightly above the bull's eye before releasing.

**Kenny:** Aimed the arrow slightly below the bull's eye before releasing.

- b) Who had the best chance of hitting the bull's eye? Give a reason for your answer. [1]

---

---



41. James placed three magnets next to one another as shown below.

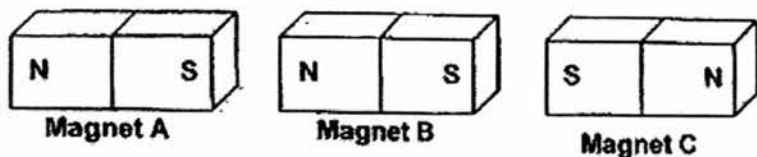

He observed what happened and wrote some statements about the magnets in the table below.

- a) Put a (✓) in the correct box to indicate whether each of the statements is 'True' 'False' or 'Not possible to tell'. [2]

	Statement	True	False	Not possible to tell
(i)	There is a pulling force between Magnet A and Magnet B.			
(ii)	A pushing force caused Magnet B and Magnet C to move apart.			
(iii)	Magnet A is made of iron.			
(iv)	Magnet B is made of copper.			

James then placed a steel thumbtack near Magnet C as shown below and observed an effect of magnetic force.

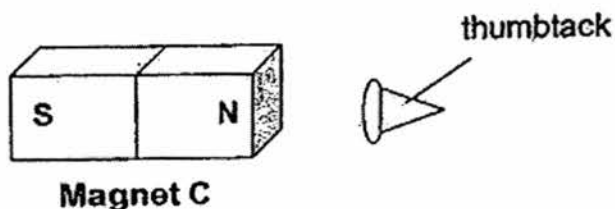

- b) What effect of magnetic force did James observe? [1]

---



---

42. As Aminah was driving to work in the morning, she turned on the air-conditioner in her car. After a while, she noticed that the windscreen and windows of her car had become misty.

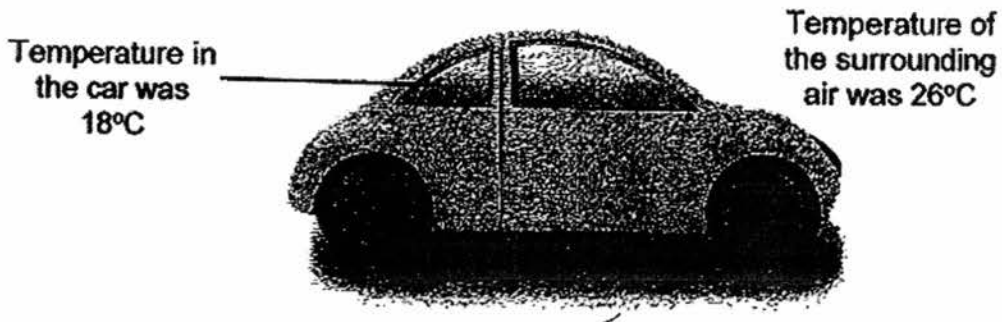

- a) On which surface (interior or exterior) of the windscreen would Aminah find the mist? Explain your answer. [2]

---

---

---

- b) Would Aminah make the same observation if the temperature in the car was  $26^{\circ}\text{C}$ ? Give a reason for your answer. [1]

---

---

43. The diagram below shows a circuit and what happens to a bulb when three bars, W, X and Y, are placed, one at a time, across AB.

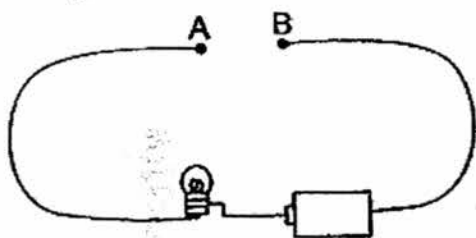

Bar across AB	Bulb lights up
W	No
X	No
Y	Yes

- a) Based on the experiment above, which bar is most likely to be a conductor of electricity? Give a reason for your answer. [1]

In another experiment, some wax was placed on the top end of the same three bars, W, X and Y. The three bars were then placed on top of a hot surface as shown below.

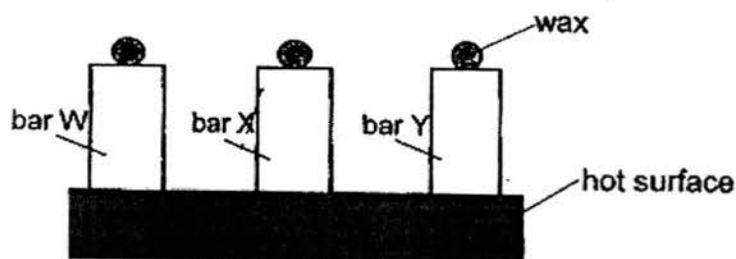

It was observed that wax on bar Y melted first, followed by that on bar X and then bar W.

- b) What conclusion can you draw about the conduction of heat of bars, W, X and Y? [1]

---



---

- c) From your answers to (a) and (b), what can you conclude about the likely relationship between a conductor of electricity and a conductor of heat? [1]

---



---

44. Dave laid some black ceramic tiles on the roof of his house as shown below. However, he found that on sunny days, the living space in his house was very warm.

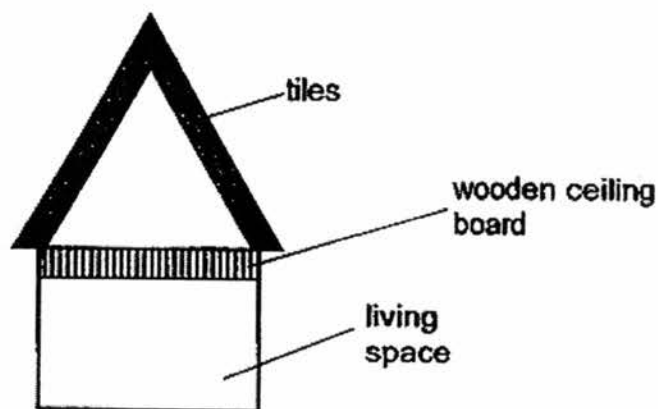

He decided to replace his original wooden ceiling board with a hollow ceiling board filled with air as shown below.

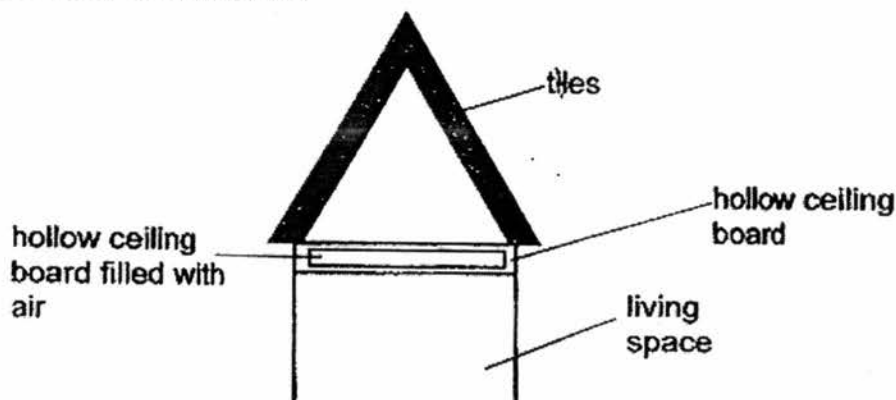

- a) How does installing the hollow ceiling board keep the living space in his house cool? [2]

---

---

---

Dave's neighbour, Tian La, told him that white tiles absorb less heat than black tiles. Dave then decided to replace the black tiles with white ones.

- b) Explain why using white tiles is a better choice for Dave. [1]

---

---

**End of Booklet B**

EXAM PAPER 2016

SCHOOL : TAONAN

SUBJECT :P6 SCIENCE

TERM : SA1

ORDER CALL :

Q1	Q2	Q3	Q4	Q5	Q6	Q7	Q8	Q9	Q10
2	1	4	2	4	2	2	1	3	4
Q11	Q12	Q13	Q14	Q15	Q16	Q17	Q18	Q19	Q20
1	3	3	2	3	1	2	1	4	4
Q21	Q22	Q23	Q24	Q25	Q26	Q27	Q28	Q29	Q30
3	1	4	2	4	1	2	3	3	4

TAO NAN SCHOOL  
MID-YEAR EXAMINATION  
PRIMARY 6 2016  
SCIENCE

Name: \_\_\_\_\_ (    )

Date: \_\_\_\_\_

Class: Pri 6/ \_\_\_\_

**Common Areas of Concerns:**

- 1) **Making general statements** instead of explaining to the context.
- 2) **Answering in terms of B**, when asked about A. (**Reverse Reasoning**)
- 3) **No comparison** shown in answer when question asked to compare or substantiate choice made
- 4) Not answering to the **context** of the question.

Question	Suggested Answer	Self-check/ What was my error?
31	<p>a It is Tree A. This is because it has <b>shorter/ less/ fewer/ less spread out/ shallower roots</b> (must show comparison), hence the Tree A is <b>anchored less firmly to the soil</b>.</p> <p>b Roots <b>take in/ absorb water (and minerals/mineral salts/ nutrients)</b> for the trees.</p>	<p><input type="checkbox"/> No comparison shown.</p> <p><input type="checkbox"/> Wrong function of roots (To transport (x) water )</p>
32	<p>(i) D</p> <p>(ii) A</p> <p>(iii) B</p> <p>(iv) C</p>	
33	<p>(a)(i) Leaf A: brown</p> <p>(a)(ii) Leaf B: dark blue/blue-black</p> <p>(b) There was <b>no carbon dioxide present for part A to photosynthesise/ to make food</b>. There was <b>no starch present</b> as the iodine solution remained brown.</p>	

Question	Suggested Answer	Self-check/ What was my error?
34	<p>(a) Beaker A was the most suitable. This is because it is the <u>only</u> beaker where the <b>number of duckweeds increased</b> or <b>there was most number of duckweeds in Beaker A at the end of experiment/at Week 5.</b> (comparison required )</p> <p>(b) As the duckweeds were covering most of the pond, they (<b>block the sunlight/ did not allow light to pass through/ prevent light from passing through</b>) from reaching the <b>submerged plants</b>. Hence, the plants <b>cannot photosynthesise, to produce oxygen</b> for the organisms in the pond and the organisms die due to a lack of dissolved oxygen.</p>	<p><input type="checkbox"/> No comparison shown</p> <p><input type="checkbox"/> Making general statements instead of explaining</p> <p><input type="checkbox"/> Explaining about leaf B instead of leaf A.</p>
35	<p>(a) The <b>bird</b> is both a prey and predator</p> <p>(b) The bird population would <b>decrease</b> because the snake population has <b>only one food source left/ less food source/ less prey</b> and will <b>feed on more birds</b>.</p>	
36	<p>(a) Section X: X's water-carrying tube (and food-carrying tube) had been cut off. <b>Water cannot reach X/ no water supply reaches X</b> and it cannot make food.  Section Y: Water-carrying tubes not removed and Section Y can still <b>receive/transport water</b> to leaves to <b>(make) food</b>.</p> <p>(b)(i) water-carrying tubes (b)(ii) food- carrying tubes</p>	
37	<p>(a) The abandoned shell that organism X carries <b>helps it to protect (itself)/ hides</b> from its <b>predators</b> to ensure its survival.</p> <p>(b)i The poison/ tentacles in organism Z keeps <b>predators</b> away from Organism X.</p> <p>(b)ii Organism Z gets to feed from the same source of food that Organism X hunts for. OR Organism X transports <b>Organism Z</b> from place to place to a <b>wider area</b> for <b>sourcing/finding food</b>. OR Organism X can help Organism Z to <b>move faster/ more quickly to eat (more) food</b>.</p>	<p><input type="checkbox"/> Not linking the adaptations/behaviours to survival ( protection from <b>predators</b>)</p> <p><input type="checkbox"/> Not linking the movement of Z to survival (<b>getting more food</b>).</p>

Question	Suggested Answer	Self-check/ What was my error?
38	<p>(a) The aim of the experiment is to find out which material/ ball is the <b>best/ poorest</b> conductor (insulator) of heat.</p> <p>(b) The amount/ volume of water. The mass/colour of the ball The location of experiment/ where the beakers are placed. The type of thermometer</p> <p>(c) Material made from Ball A is to be used. The temperature of the water is the lowest <b>at the end of experiment/ the water took the longest time to increase its temperature/ poorest conductor of heat/ best insulator of heat</b> therefore the <b>food will lose heat the slowest</b> to the surroundings.</p>	<p><input type="checkbox"/> Self-check/ What was my error?</p> <p><input type="checkbox"/> No comparison shown.</p> <p><input type="checkbox"/> Listing variables already stated kept the same in the question.</p> <p><input type="checkbox"/> Not stating <b>evidence</b> from data</p> <p><input type="checkbox"/> Not linking <b>concept</b> (material chosen reduced heat lost from heat source/food to surrounding) to the <b>context (food)</b></p>
39	<p>(a) Elastic Band Y has the most elastic potential energy. This is because it caused the <b>steel ball to swing the highest</b>.</p> <p>(b) When the elastic band is stretched further, it will have <b>more elastic potential energy, to be converted into (more) kinetic energy of the elastic band</b> to be transferred to the marble thus <b>hitting the steel ball with a greater impact for it to swing higher</b>.</p> <p>OR</p> <p>When the elastic band is stretched further, it will have <b>more elastic potential energy, to be converted into (more) kinetic energy of the elastic band</b> to be transferred to the marble thus <b>Transferring more kinetic energy to the steel ball (so that it can be converted into more gravitational potential energy), hence swinging to a higher height</b>.</p>	<p><input type="checkbox"/> Not using <b>evidence</b> from data to support selection.</p> <p><input type="checkbox"/> Not being clear which <b>object</b> (elastic band /marbles/steel ball) possess which energy at each point.</p> <p><input type="checkbox"/> Confused between energy conversion and energy transfer.</p>
40	<p>(a) The two forces are <b>gravitational force (gravity)</b> and <b>frictional force (friction)</b>.</p> <p>(b) <b>Paul</b> has the best chance of hitting a bull's eye. This is because <b>gravity will pull the arrow downwards</b>. Hence, if the arrow is aimed slightly above the bull's eye, the chance of hitting the bull's eye is highest, compared to the other two arrows.</p>	<p><input type="checkbox"/> Confused between <b>energy</b> and <b>forces</b>.</p>



Question	Suggested Answer		Self-check/ What was my error?
41	(a)i True (a)ii True (a)iii Not Possible To Tell (a)iv False  (b) The thumbtack was <b>attracted to/moved towards/pulled towards</b> to Magnet C		
42	(a) Amirah would find mist on the <b>exterior</b> of the windscreen. The <b>warmer water vapour in the surroundings</b> came into contact with the <b>cooler windscreen</b> . This caused the water vapour to <b>condense</b> on the exterior of the windscreen, to form tiny water droplets/mist.  (b) No she will not. This is because <b>the temperature of the air in the car and temperature of the air in the surroundings are nearly the same</b> . As such, <b>minimum condensation/ no condensation/ no heat transfer</b> takes place on the surface on the windscreen.		<ul style="list-style-type: none"> <li>❑ Wrong concept of <u>air</u> condensing</li> <li>❑ Not clear about the windscreen being <u>cooler</u> than the water vapour ( no comparison)</li> </ul>
43	(a) Bar Y is most likely the conductor of electricity. <b>Bar Y was the only bar that caused the bulb to light up</b> when it was placed across AB.  (b) Bar Y is the <b>best conductor of heat</b> followed by Bar X and then Bar W.  (c) A (good) conductor of electricity is also a (good) conductor of heat.		
44	(a) As <u>air</u> is a <b>poor conductor of heat</b> , the air in the gap <b>slows down/ reduces the heat gain</b> from the roof to the living space in the house.  (b) White ceramic gains less heat, hence help to keep the living space cooler.		<ul style="list-style-type: none"> <li>❑ Did not use science concept to explain how the air reduces heat gain/transfer from roof to living space. (heat source or direction of movement of heat not clear)</li> <li>❑ No <u>comparison</u> of the effect of white tiles on Dave's living space.</li> </ul>