

METHODIST GIRLS' SCHOOL (PRIMARY)

Founded in 1887



MID-YEAR EXAMINATION 2011 PRIMARY 6 SCIENCE

BOOKLET A

Total Time for Booklets A and B: 1 hour 45 minutes

INSTRUCTIONS TO CANDIDATES

Do not turn over this page until you are told to do so.
Follow all instructions carefully.

Answer all questions.

Shade your answers in the Optical Answer Sheet (OAS)
provided.

Name: _____ ()

Class: Primary 6. _____

Date: 10 May 2011

This booklet consists of 16 printed pages including this page.

For each question from 1 to 30, four options are given. One of them is the correct answer. Make your choice (1, 2, 3 or 4). Shade the correct oval (1, 2, 3 or 4) on the Optical Answer Sheet provided. (60 marks)

1 Which of the following best fits the descriptions given below?

- They live in land and water
- They have moist skin
- They breathe through the lungs and skin
- Their eggs do not have shells

- (1) Reptiles
- (2) Birds
- (3) Amphibians
- (4) Mammals

2 Study the classification table below.

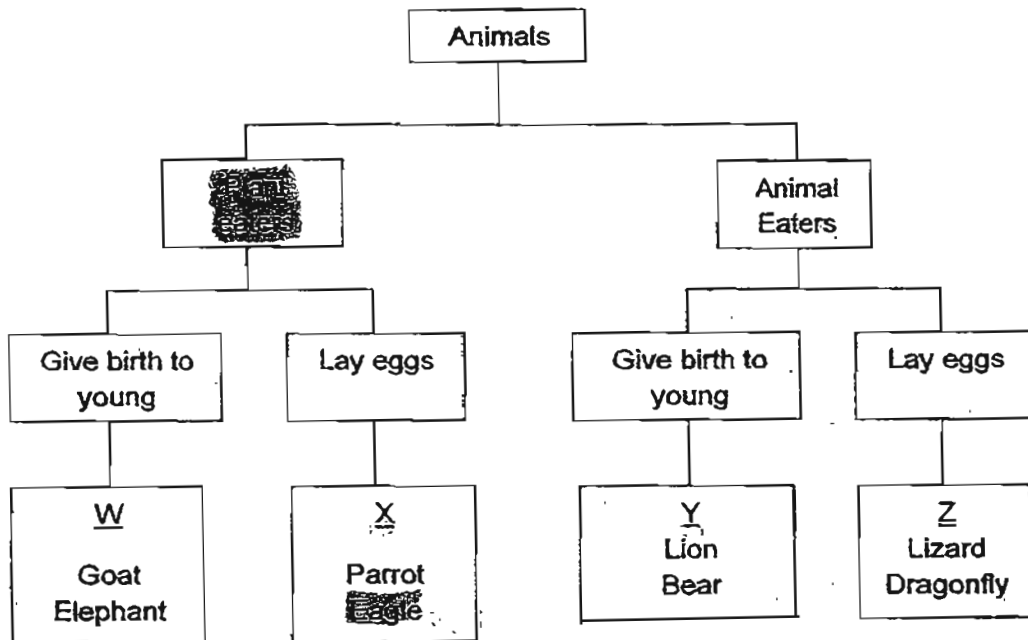

Which group of animals is wrongly grouped?

- (1) W
- (2) X
- (3) Y
- (4) Z

(Go on to the next page)

- 3 Study the table below. Which fruit/s is/are likely to be dispersed by animals?

Fruit	Observations
X	Brown coloured, small, light and has hooks
Y	Fleshy, juicy and is brightly coloured
Z	Grey coloured, flat, thin and light

- (1) Y only
 (2) X, Y and Z
 (3) X and Y only
 (4) None of the above
- 4 Mei Ling conducted an experiment with the flowering plants in her garden. She wanted to find out whether a fruit can be produced if a certain part of the flower is removed. She used the same type of flowers for her experiment.

Flower X	Petals removed
Flower Y	Anther removed
Flower Z	Style removed

Mei Ling then dusted some pollen grains from the same type of flowers on Flower X, Y and Z. She observed them for 2 weeks. Which of the above flowers will most likely produce fruits after 2 weeks?

- (1) Flowers X and Y only
 (2) Flowers Y and Z only
 (3) Flowers X and Z only
 (4) Flowers X, Y and Z

(Go on to the next page)

5 Photosynthesis is a very important process because it

- A: takes place all the time
 B: removes carbon dioxide from the air
 C: allows plants to make the food they need
 D: produces oxygen which is used by animals and man for respiration

- (1) A and D only
 (2) B and C only
 (3) A, B and D only
 (4) B, C and D only

6 Which of the following statements below correctly describes the difference between inhaled and exhaled air?

- (1) Inhaled air is warmer than exhaled air
 (2) Inhaled air has more oxygen than exhaled air
 (3) Exhaled air has more nitrogen than in inhaled air
 (4) Exhaled air has less carbon dioxide than in inhaled air

7 The table below shows the processes and actions involved during respiration. Which explanation is incorrect?

	Processes and Actions	Explanation
(1)	Breathing	The taking in of oxygen
(2)	Respiration	The release of energy from food
(3)	Exhalation	The breathing out of air from lungs
(4)	Inhalation	The breathing in of air into the lungs

(Go on to the next page)

- 8 The table below lists some parts of the human digestive system and their respective functions. Which one of the parts and its function is matched **incorrectly**?

	Parts	Function
(1)	Anus	Faeces are passed out of the body through the anus.
(2)	Stomach	Breakdown of fats begins here with gastric juices.
(3)	Large intestine	Water and mineral salts are absorbed here.
(4)	Salivary glands	Produces an enzyme that breaks down starch.

- 9 Mike placed a thick liquid called glycerine, a tennis ball and some red beans into a plastic bag. He then tied the mouth of the bag to make a ~~model of an animal cell~~. The ~~red beans~~ ~~are~~ ~~small~~ ~~particles~~. What do the three things listed in the table below represent in the cell?

	Glycerine	Tennis ball	Plastic bag
(1)	Chromosomes	Nucleus	Cell wall
(2)	Cytoplasm	Genes	Cell membrane
(3)	Nucleus	Chloroplasts	Cell wall
(4)	Cytoplasm	Nucleus	Cell membrane

- 10 It requires more than one body system to work together to perform an activity. Which of the following body systems work together to ~~supply oxygen to all parts of the human body~~?

- A: Skeletal system
 B: Respiratory system
 C: Circulatory system
 D: Muscular system

- (1) A and B only
 (2) A and C only
 (3) B and C only
 (4) B and D only

(Go on to the next page)

- 11 The diagram below shows a food web. What do you think will happen immediately after a great increase in the number of caterpillars?

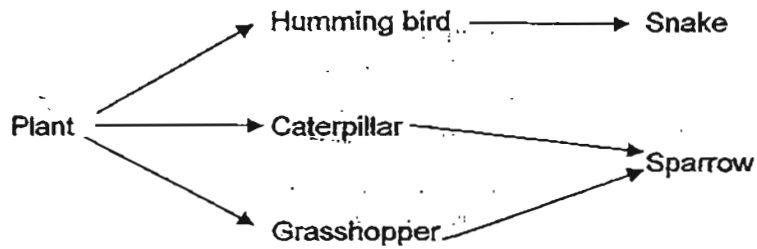

- A: Many sparrows will have no food to eat.
 B: There will not be enough food for the other herbivores.
 C: The population of snakes will decrease.
- (1) A and B only
 (2) B and C only
 (3) A and C only
 (4) A, B and C
- 12 Which of the following animal cells pass genetic information from parent to offspring?
- (1) Ovum and sperm
 (2) Brain cell and ovum
 (3) Sperm and blood cell
 (4) Blood cell and brain cell

(Go on to the next page)

13 Study the food web of a community shown below.

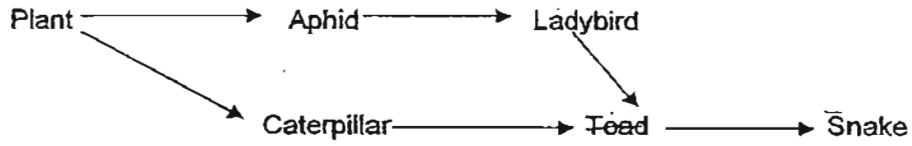

Which of the following graphs shows how the population of aphids (A), ladybirds (L), Caterpillars (C) and snakes (S) are likely to be affected if all the toads were removed from the above community?

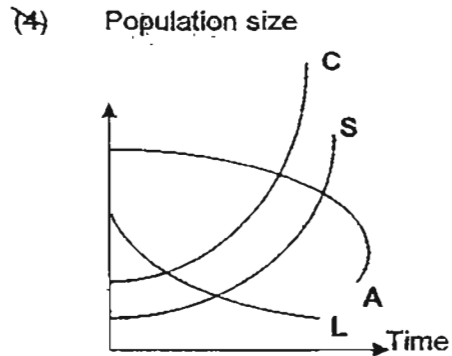
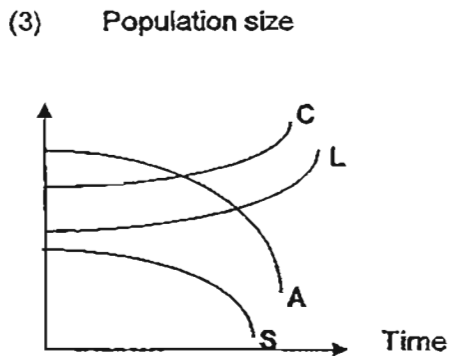
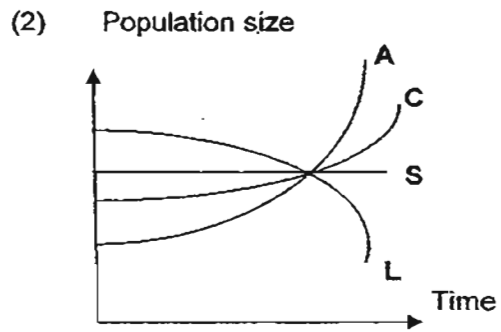
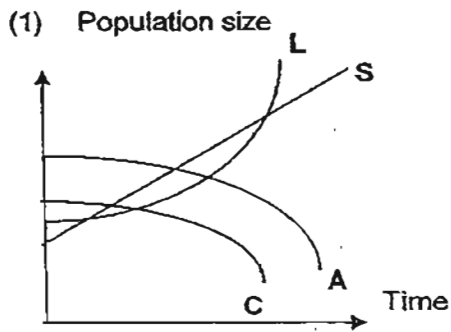

(Go on to the next page)

- 14 Look at the food web below.

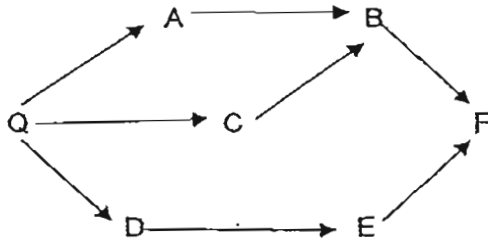

Which of the following is true about the living things depicted in the food web?

- A: C is a plant
 B: A, C and D are herbivores
 C: E and B are both prey and predator
 D: F is a carnivore

- (1) A and B only
 (2) B and C only
 (3) A, B and D only
 (4) B, C and D only
- 15 Study the graph below carefully. It shows a number of guppies in an aquarium. A few angelfish were introduced and then taken out after a few days. When were the angelfish introduced and taken out respectively?

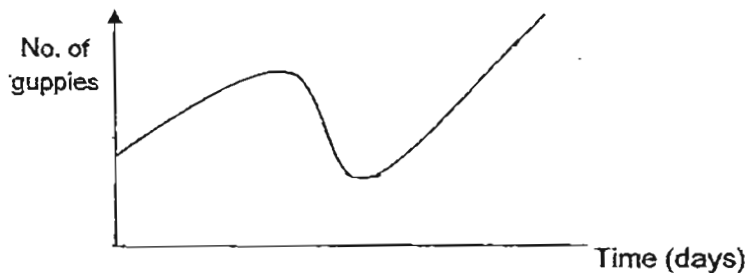

- (1) A and C
 (2) A and D
 (3) B and C
 (4) C and D

(Go on to the next page)

- 16 Esther was given a beaker containing a mixture of iron filing, sugar and sand. She jotted down the possible properties of these substances as shown below:

Property A: It can float on water
Property B: It is a magnetic material
Property C: It can dissolve in the water
Property D: It is a good conductor of heat

Which property/properties should Esther make use of in order to separate the three substances?

- (1) A and B
 (2) B and C
 (3) C and D
 (4) A and D
- 17 Wati filled up a syringe with a substance and set up the experiment as shown.

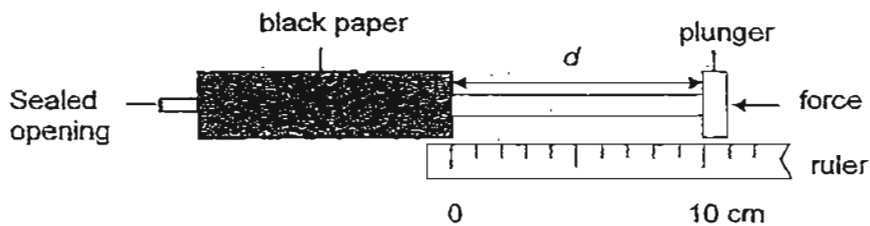

She pushed the plunger as hard as possible and measured the distance, d . She repeated the experiment twice with different substances. The distances for substances X, Y and Z are recorded in the table below.

Substance	X	Y	Z
d (cm)	6	1	10

Which one of the following shows the correct states of matter for each substance?

Substance	X	Y	Z
(1)	Solid	Liquid	Gas
(2)	Gas	Liquid	Solid
(3)	Liquid	Gas	Solid
(4)	Gas	Solid	Liquid

(Go on to the next page)

18 Sam heated a beaker of ice till it turned into water and started to boil. After boiling for some time, he switched off the heater and let the water cool. Which one of the following graphs shows the changes in the temperature of the water correctly?

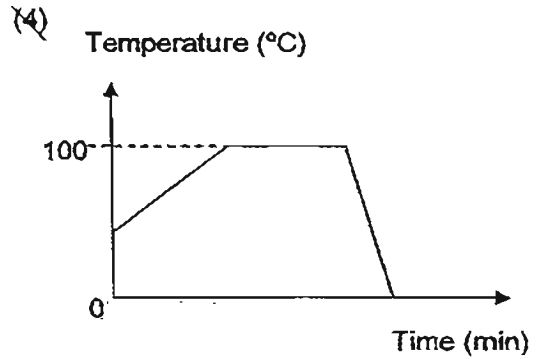
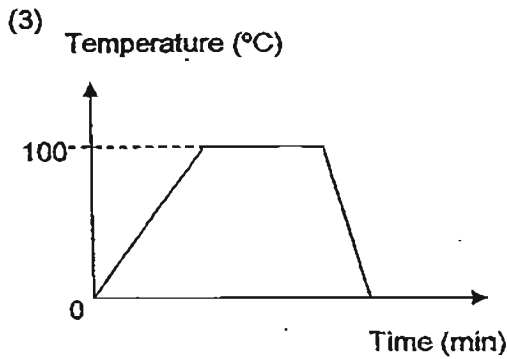
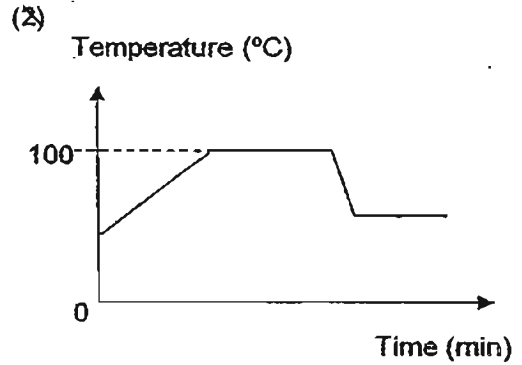
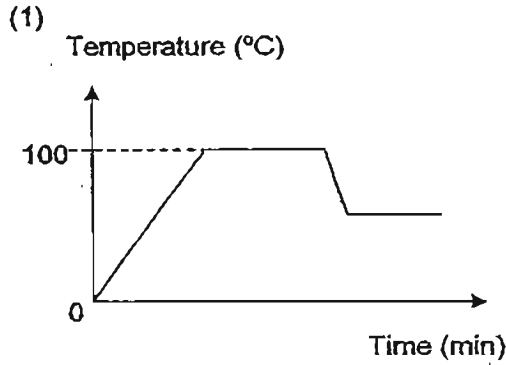

19 Study the three circuits P, Q and R as shown below.

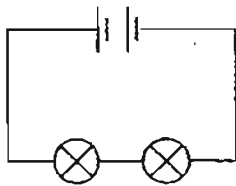

Circuit P

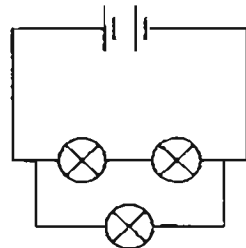

Circuit Q

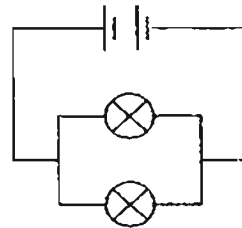

Circuit R

The bulbs and the batteries in the three circuits are identical. All the bulbs are lit up. Which one of the following statements about the brightness of the bulbs is correct?

- (1) The bulbs in circuit R are the brightest.
- (2) All the three bulbs in circuit Q have the same brightness.
- (3) The bulbs in circuit P are as bright as the bulbs in circuit R.
- (4) The bulbs in circuit P are brighter than the bulbs in circuit Q.

(Go on to the next page)

- 20 The diagram below shows a horseshoe magnet dropped flat into a container of iron filings.

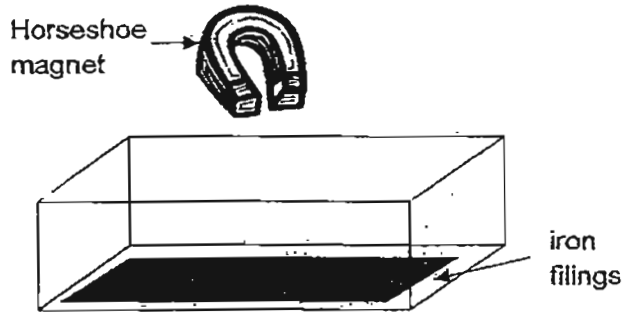

Which one of the following diagrams best shows how much iron filings were attracted at the different parts of the horseshoe magnet?

(2)



Iron filings covered the whole horseshoe magnet

(2)



More iron filings covered the two poles of the horseshoe magnet

(2)



More iron filings covered the centre portion of the horseshoe magnet

(4)

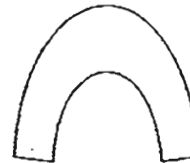

No iron filings covering the horseshoe magnet

(Go on to the next page)

- 21 Xiu Xiu conducted an experiment on two elastic Ropes K and L. She hung various loads one at a time and recorded the length of the rope. She then plotted a graph to show the results.

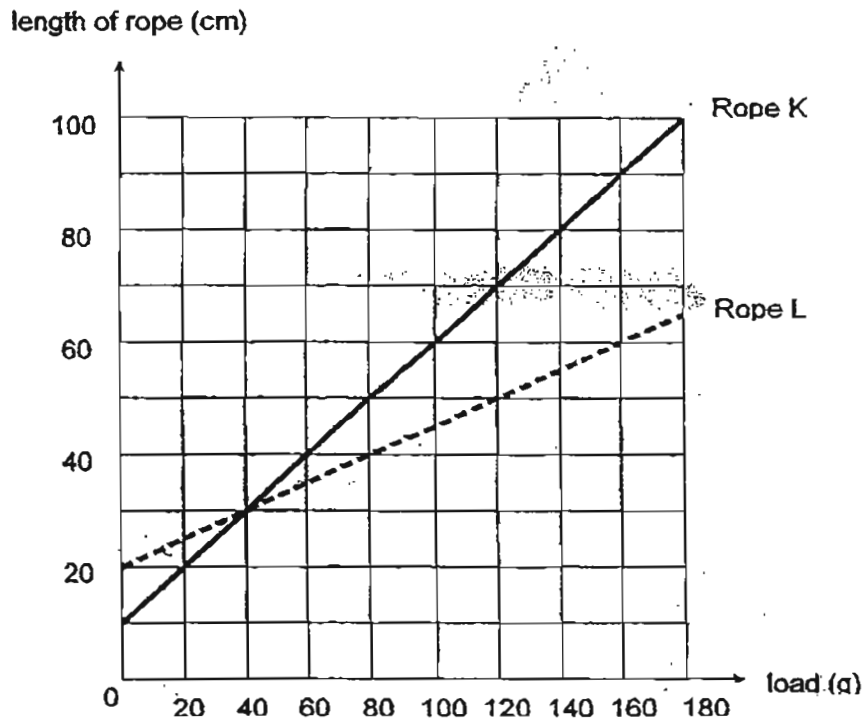

What can Xiu Xiu conclude from this graph?

- (1) Rope K is as elastic as Rope L.
- (2) Rope K is more elastic than Rope L.
- (3) Rope L is more elastic than Rope K.
- (4) The elasticity of the ropes depends on the loads.

(Go on to the next page)

- 22 Darlene set up an experiment as shown below.

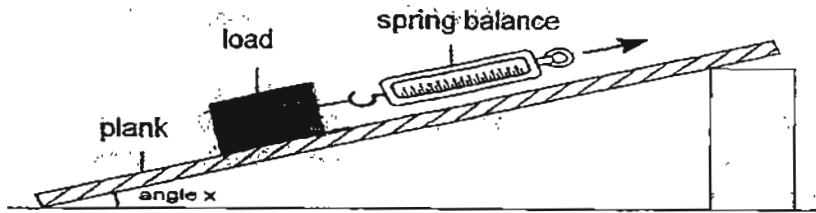

The spring balance measures the force needed to overcome _____.

- (1) friction
 - (2) gravity
 - (3) gravity and friction
 - (4) the elastic spring force
- 23 Fann conducted an experiment using the set-up shown below.

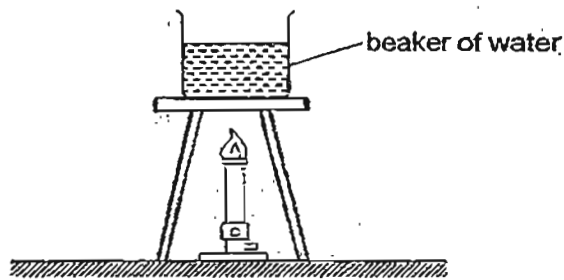

She recorded the time taken for the water to boil and repeated the same experiment for another two liquids, U and V. The table below shows the results.

Liquid	Time taken for the liquid to start boiling (min)
Water	10
U	20
V	6

Which of the following statements is true about the liquids?

- (1) Liquid U conducts heat better than water.
- (2) Liquid V conducts heat better than Liquid U.
- (3) Liquid U conducts heat better than Liquid V.
- (4) Water conducts heat better than Liquid U and V.

(Go on to the next page)

24 An architect wanted to design a special house in Singapore. He wanted to use glass for the roof of the house. He was told that this was not suitable in Singapore. Why is this so?

- (1) Glass is a poor conductor of heat, thus it does not allow heat to enter easily.
- (2) Glass is a poor conductor of heat, thus it does not allow trapped heat to escape easily.
- (3) Glass is a good conductor of heat, thus it allows trapped heat to escape easily.
- (4) Glass is a good conductor of heat, thus it allows heat to enter easily.

25 Kangxi saw a shadow on the screen as shown below.

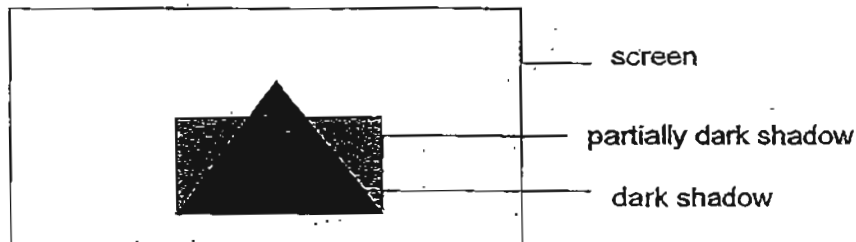

Which one of the following objects do you think could have cast the shadow above?

- (1) A translucent triangle and an opaque rectangle
- (2) A transparent triangle and an opaque rectangle
- (3) An opaque triangle and a translucent rectangle
- (4) An opaque triangle and a transparent rectangle

26 A boy was blowing soap bubbles out in the field on a sunny day.

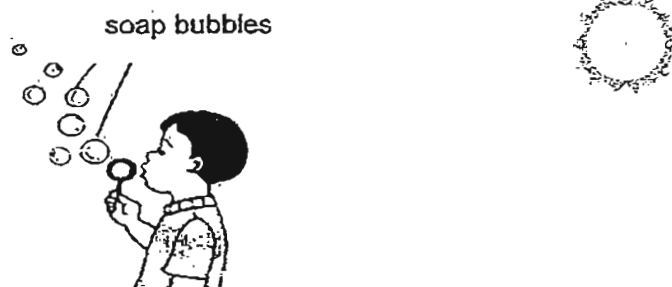

Which one of the following statements correctly explains the path of light that enables the boy to see the soap bubbles?

- (1) From soap bubbles to boy to sun
- (2) From sun to boy to soap bubbles
- (3) From boy to sun to soap bubbles
- (4) From sun to soap bubbles to boy

(Go on to the next page)

- 27 Many countries use a hydroelectric dam to generate electricity. Which one of the following shows the energy changes from the water in the reservoir to the generator?

(1)	heat energy of water in the reservoir	→	gravitational potential energy of moving water	→	electrical energy in generator
(2)	heat energy of water in the reservoir	→	kinetic energy of moving water	→	electrical energy in generator
(3)	gravitational potential energy of water in the reservoir	→	kinetic energy of moving water	→	electrical energy in generator
(4)	kinetic energy of water in the reservoir	→	kinetic energy of moving water	→	electrical energy in generator

- 28 Ali created a toy with a thick wooden stick and some paper as shown below. He would release the toy by sliding his right hand forward and his left hand backwards. Upon release, the toy would fly to a certain height.

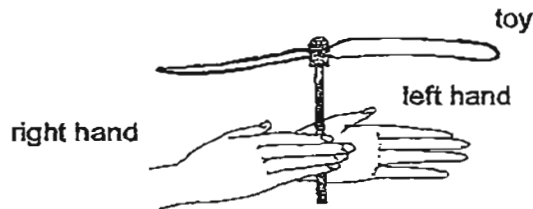

What causes the toy to be able to fly to a certain height?

- (1) The heat energy from the hand
- (2) The kinetic energy from the hand
- (3) The chemical potential energy of the toy
- (4) The gravitational potential energy of the toy

(Go on to the next page)

29 The Singapore Government wants to make Singapore an environmentally friendly nation. They install solar panels on the street lamps along the parks. What is one of the possible reasons for the government to do that?

- (1) Solar energy is free and reliable.
- (2) Solar energy is in abundance throughout the year in Singapore.
- (3) It is cheaper to install the solar panels than the normal light bulbs.
- (4) Singaporeans seldom stroll at night, thus they do not need the street lamps.

30 Study the classification table below.

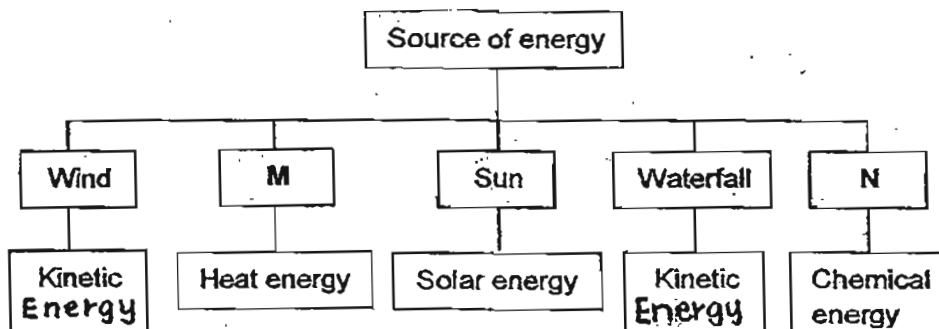

Which one of the following options will best represent M and N?

	M	N
(1)	Biomass	Geothermal
(2)	Oil	Natural Gas
(3)	Geothermal	Coal
(4)	Oil	Biomass

METHODIST GIRLS' SCHOOL (PRIMARY)

Founded in 1887



MID-YEAR EXAMINATION 2011 PRIMARY 6 SCIENCE

BOOKLET B

Total Time for Booklets A and B: 1 hour 45 minutes

INSTRUCTIONS TO CANDIDATES

Do not turn over this page until you are told to do so.

Follow all instructions carefully.

Answer all questions.

Write your answers in this booklet.

Name: _____ ()

Class: Primary 6. _____

Date: 10 May 2011

Booklet A	/ 60
Booklet B	/ 40
TOTAL	/ 100

This booklet consists of 15 printed pages including this page.

For questions 31 to 44, write your answers in this booklet.

The number of marks available is shown in brackets () at the end of each question or part question. (40 marks)

- 31 Sam, Peter and Kevin drew up the following classification chart for their project. Mrs Tan, their Science teacher told the boys that one of them has been incorrectly grouped.

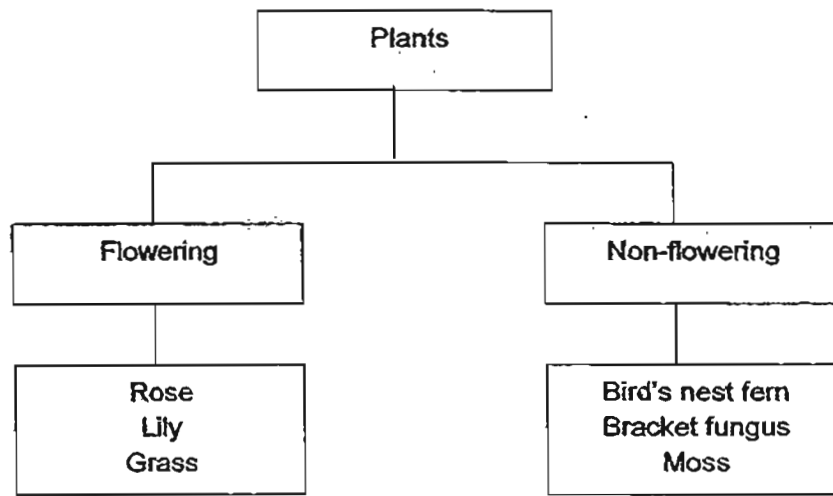

- (a) Which one of the following organism is grouped wrongly? Give a reason for your answer. (1 m)
- _____
- _____
- (b) Which group of living things should the organism in (a) be classified? (1 m)
- _____

(Go on to the next page)

SCORE	2
-------	---

32 The diagram below shows Jenny's family tree.

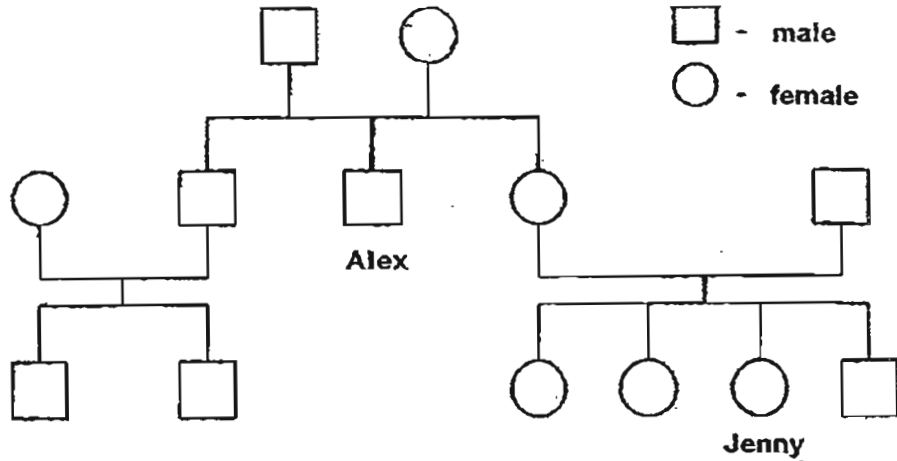

- (a) Shade the shape that represents Jenny's grandmother. (1 m)
- (b) How is Alex related to Jenny? (1 m)
-

33 Water is being ~~carried by tubes in plants~~ and ~~by blood in humans~~.

(a) Name ~~the system~~ found in

(i) Plants: _____ (1 m)

(ii) Animals: _____ (1 m)

(b) How are these systems in (a) similar in plants and animals? (1 m)

(Go on to the next page)

SCORE	5
-------	---

34 Study the food web shown below and answer the following questions.

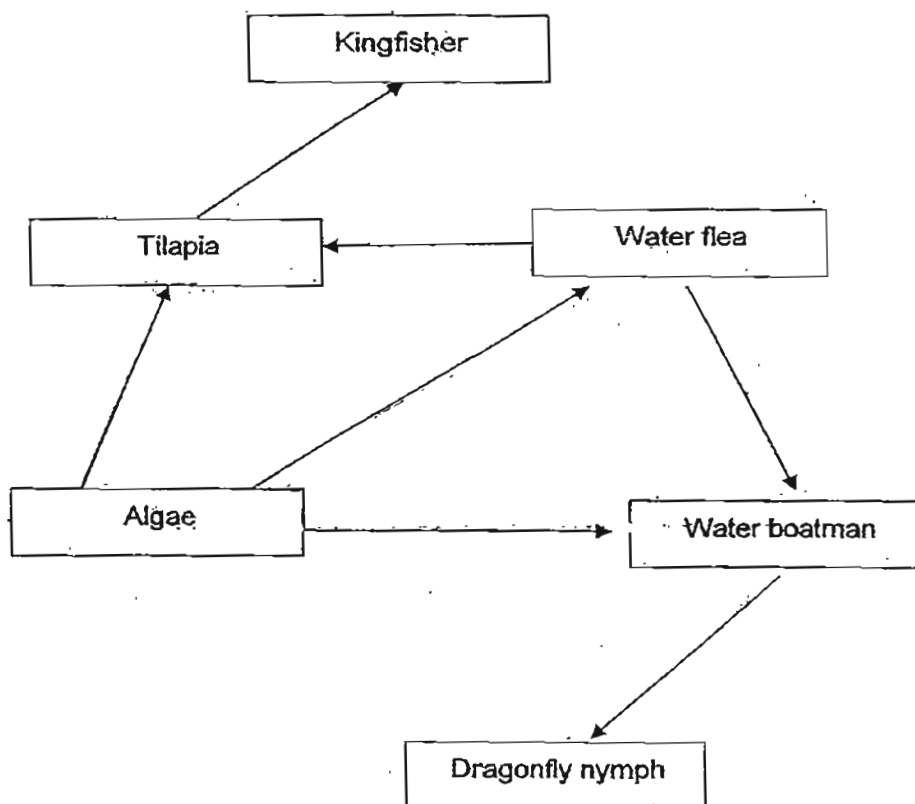

(a) Name the food producer in this food web. (1 m)

(b) How many consumers are there in this food web? (1 m)

(c) What is the role of the food producer in this food web? (1 m)

(Go on to the next page)

SCORE	3
-------	---

- 35 Mei Mei sets up an experiment. The conditions used for the experiment are shown in the table below.

Conditions	Pot W	Pot Z
Number of seeds	5	15
Amount of water	50 ml	50 ml
Location of pot	In the garden	In the garden
Type of soil	Garden soil	Garden soil

- (a) Based on the table above, what do you think Mei Mei was trying to find out? (1 m)

- (b) Which pot of plants do you think will grow well? (1 m)

- (c) Explain your answer in (b). (1 m)

(Go on to the next page)

SCORE	3
-------	---

- 36 Study the observations as recorded in the table below.

Cell specimen	P	Q	R
Presence of cell wall?	Yes	No	No
Presence of a nucleus?	Yes	Yes	No
Presence of chlorophyll?	Yes	No	No

- (a) Based on the table above, which cell specimen is ~~likely to be taken from a dead ant?~~
~~likely to be taken from a dead ant?~~ Explain your answer. (1 m)

- (b) Which cell specimen is likely to be taken from a dead ant? Explain your answer. (1 m)

(Go on to the next page)

SCORE	2
-------	---

37 Study the statements below.

- Q feeds on P.
- Q is the prey to S.
- R is the predator of Q.
- S is a ~~prey to R~~

(a) Based on the given information, draw a simple food web to show the relationships among the organisms.

(3 m)

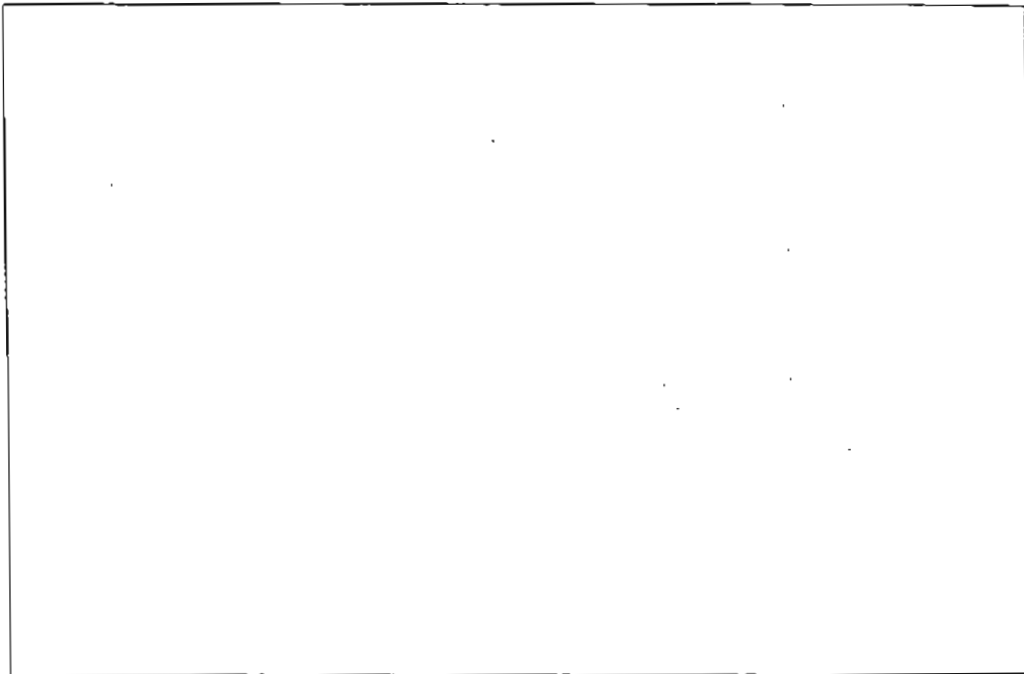

(b) Identify the plant eater.

(1 m)

(Go on to the next page)

SCORE	4
-------	---

38 Study the flow chart carefully.

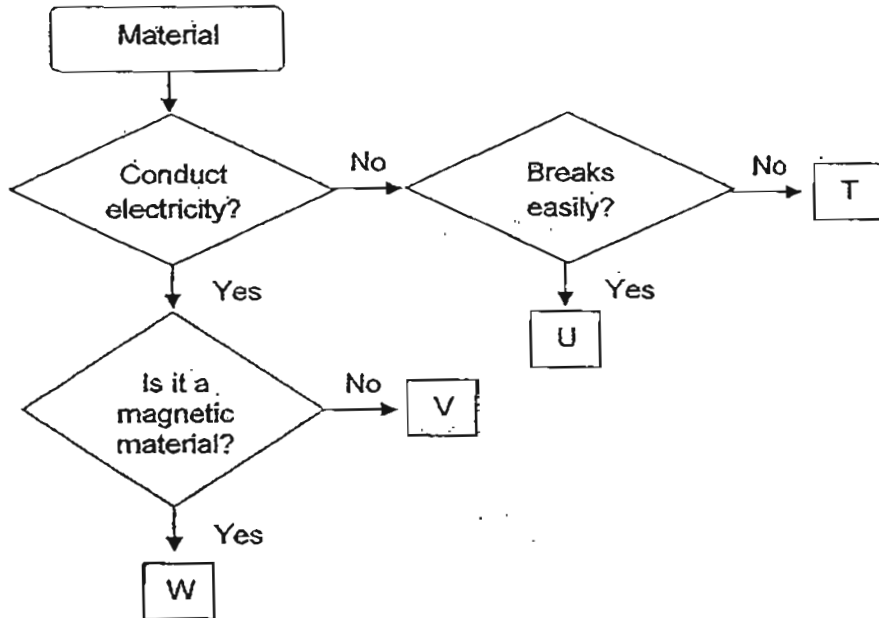

Write the letters T, U, V and W that best match the materials below:

(a) Glass : _____

(b) ^{copper}~~Nickel~~ : _____

(c) Steel : _____

(d) Rock : _____

(2 m)

(Go on to the next page)

SCORE	2
-------	---

- 39 Aram filled two identical beakers with an equal amount of water and sealed them with a thin sheet of cellophane plastic. He placed Beaker C under the sun and Beaker D in a windy and cool room.

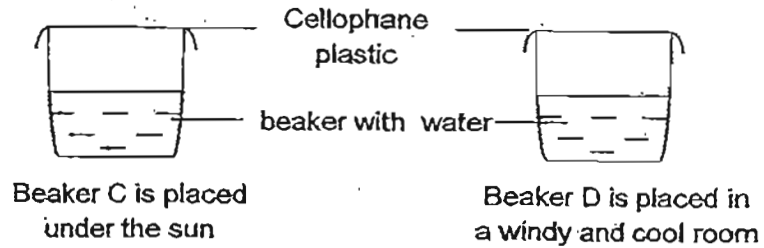

- (a) What would he observe about the two cellophane plastic after 6 hours? (1 m)

- (b) Explain the above observation. (1 m)

(Go on to the next page)

SCORE	<hr/>
	2

- 40 Jen has set up the circuit as shown below in the diagram. The bulb will light up when the switch arm is connected to X.

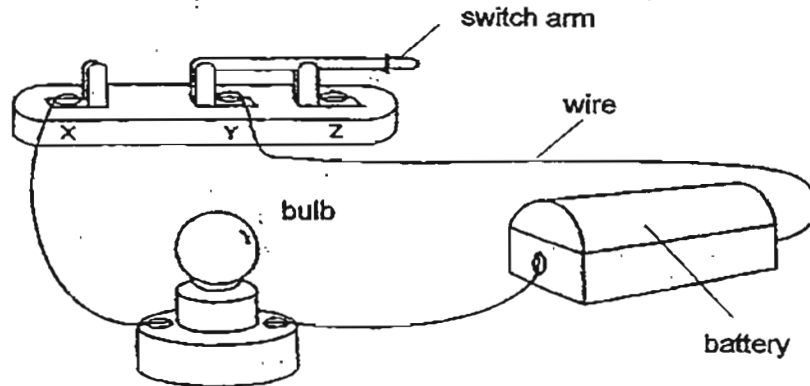

- (a) Name the form(s) of energy in the bulb. (1 m)

- (b) If Jen would like to light up another bulb of the same brightness in the above circuit, how should she arrange the bulb? (1 m)

- (c) After half an hour, it was observed that the bulb in the above circuit did not light up. State one possible reason for this observation. (1 m)

- (d) State one safety measure when using electricity. (1 m)

(Go on to the next page)

SCORE	4
-------	---

- 41 Durian is a tropical fruit in Singapore. This fruit drops from the tree when it is ripe.

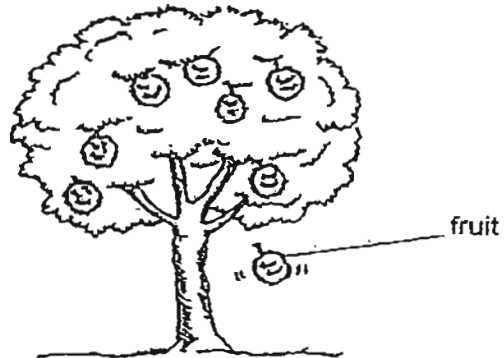

- (a) What causes the fruit to fall towards the ground? (1 m)

- (b) One day, Savia went to Pulau Ubin Island and saw a few durians fall to the ground. He observed that they fell with various degrees of loudness. Explain the observation. (2 m)

(Go on to the next page)

SCORE	3
-------	---

- 42 Tim was skating down a slope of two different surfaces, G and H. The two graphs below show the amount of energy produced.

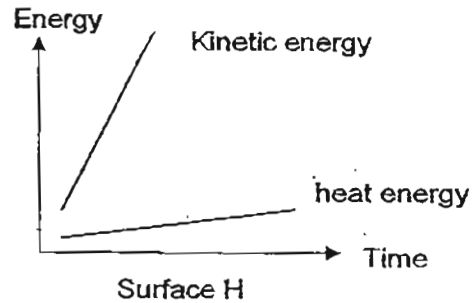
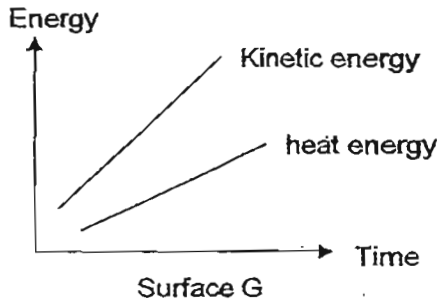

- (a) Interpret the graph for Surface G. (1 m)

- (b) Which surface would Tim skate faster on? Explain why. (2 m)

(Go on to the next page)

SCORE	3
-------	---

- 43 Look at the diagram of the metal cooking pot.

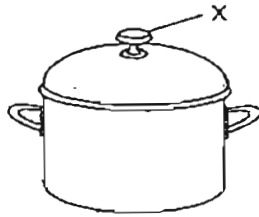

- (a) Name a material that is suitable for making the part labelled X. (1 m)

- (b) After cooking a pot of hot soup using the above cooking pot, the pot is usually placed on a mat rather than directly on the table.

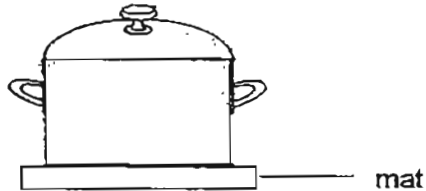

- State 2 advantages of using the above mat. (2 m)

Advantage 1 : _____

Advantage 2 : _____

(Go on to the next page)

SCORE	3
-------	---

44 The diagrams below show the energy conversion in different scenarios. Fill in the blanks with the correct forms of energy.

(a) In a power station, oil is burnt to generate electricity. (1 m)

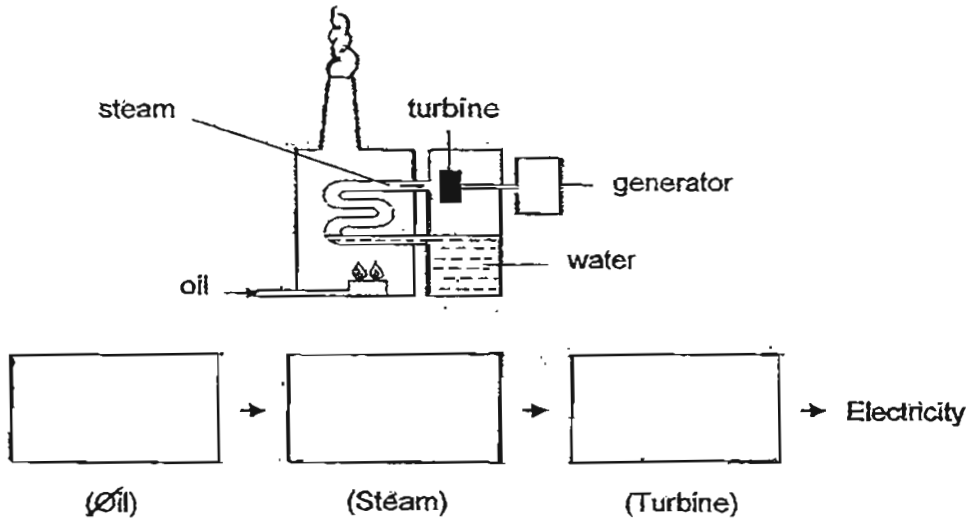

(b) After Mr Tam pedals the bicycle for a short while, the dynamo fixed at the tyre will cause the headlamp to light up. Once he stops pedalling, the headlamp will not light up. (1 m)

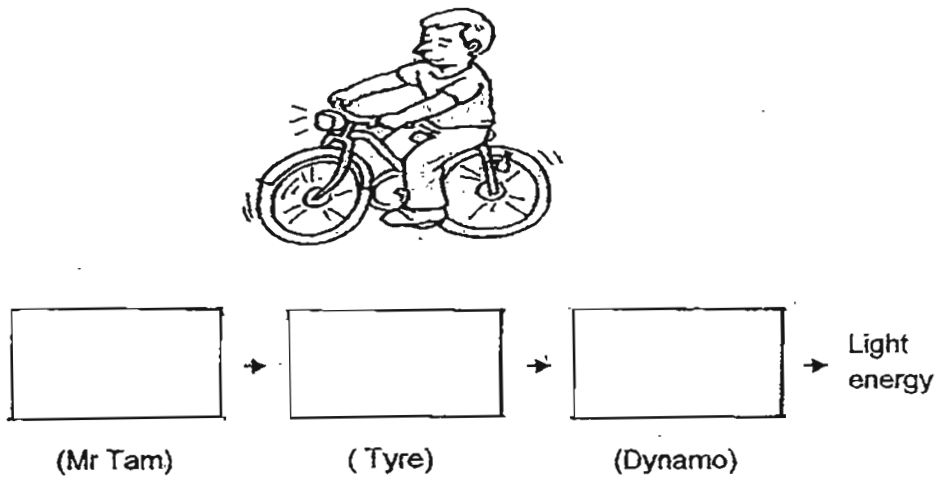

(Go on to the next page)

SCORE	2
-------	---

- (c) Edward stuck a copper wire at one end of a lemon and another copper wire at the opposite end. Then he connected the free ends of the wire to a small beeping device. The beeping device provided a small beeping sound. (1 m)

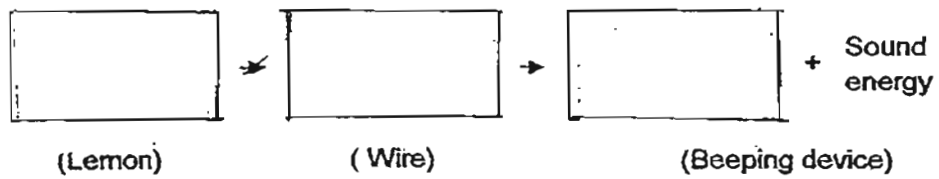
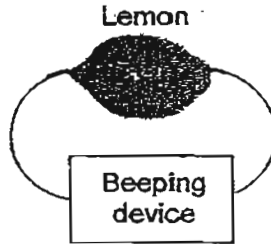

SCORE	1
-------	---



ANSWER SHEET

EXAM PAPER 2011

**SCHOOL : MGS PRIMARY
SUBJECT : PRIMARY 6 SCIENCE**

TERM : SA1

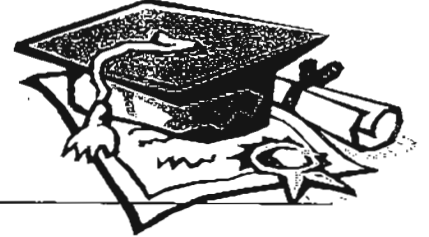

Q1	Q2	Q3	Q4	Q5	Q6	Q7	Q8	Q9	Q10	Q11	Q12	Q13	Q14	Q15	Q16	Q17
3	2	3	1	4	2	1	2	4	3	2	1	3	4	3	2	3

Q18	Q19	Q20	Q21	Q22	Q23	Q24	Q25	Q26	Q27	Q28	Q29	Q30
1	1	2	2	3	2	2	3	4	3	2	2	3

31)a) Bracket fungus. Bracket fungus does not contain chloroplasts thus they cannot photosynthesis, as all plants photosynthesis, bracket fungus is not a plant.

b) Fungus.

32)a)

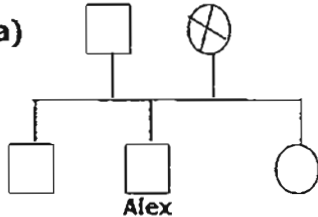

b) Alex is Jenny's uncle.

33)a) i) Plant transport system. ii) Circulatory system.

b) They transport food, water and nutrients in plants and animals.

34)a) Algae.

b) 5.

c) It makes use of the energy from the sun to make food and this energy is passed down the food web when plant eaters eat plants and where animal eaters eat plant eaters.

35)a) She was trying to find out if overcrowding affects the growth of plants.

b) Pot W.

c) There are only 5 plants growing in pot W, thus they do not need to compete for water and sunlight, unlike the plants in pot Z.

- 36)a) Cell P. All plant cells contain a cell wall and they need chlorophyll to photosynthesize, cell P contains these features so it can be considered as a plant cell.
 b) Cell Q. As a dead ant is an animal, the ant's cells would contain a nucleus, cell membrane and cytoplasm, cell Q is a suitable cell as apart from not containing a cell wall and chlorophyll, it contains a nucleus.

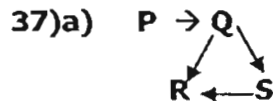

b) Q

- 38)a) U b) V c) W d) T

- 39)a) There were more water droplets under the cellophane sheet of Beaker C than D.
 b) The rate of evaporation is faster under the sun than in the room.

- 40)a) Light and heat energy.
 b) She should arrange the bulb in parallel.
 c) The bulb had been overheated and the bulb had blown, causing an open circuit.
 d) We should ensure that there is a circuit breaker or fuse connected to the circuit.

- 41)a) Gravity.
 b) The durians grew at different height on the tree so, if the durian grew at one of the higher branches, it would have more gravitational potential energy and when the durian drops and hits the ground, it would have more sound energy, thus it will produce a louder sound.

- 42)a) There was more kinetic energy than heat energy at any moment of time.
 b) Tim experienced more kinetic energy than heat energy on surface H than G causing him to skate faster.

- 43)a) Plastic.
 b) 1) The mat keeps the soup warmer for a longer period.
 2) You will not burn the surface of the table that you place the pot on.

- 44)a) Chemical potential Energy → Kinetic + Heat energy → kinetic energy
 b) Chemical potential energy → kinetic energy → Electrical energy
 c) Chemical potential energy → Electrical energy → Heat energy