

Name : _____ ()

Class : Primary 6 _____

CHIJ ST NICHOLAS GIRLS' SCHOOL



Primary 6

Semestral Assessment 1 – 2009

SCIENCE

BOOKLET A

14th May 2009

Total Time for Booklets A and B: 1 hour 45 minutes
This Booklet consists of 25 printed pages.

30 questions
60 marks

Do not open this booklet until you are told to do so.
Follow all instructions carefully.
Answer all questions.

Section A : (30 x 2 marks)

For each question from 1 to 30, four options are given. One of them is the correct answer. Make your choice (1, 2, 3 or 4). Shade the correct oval (1, 2, 3 or 4) on the Optical Answer Sheet provided.

1. The plants in the diagram below have been classified according to the plant parts they reproduce from.

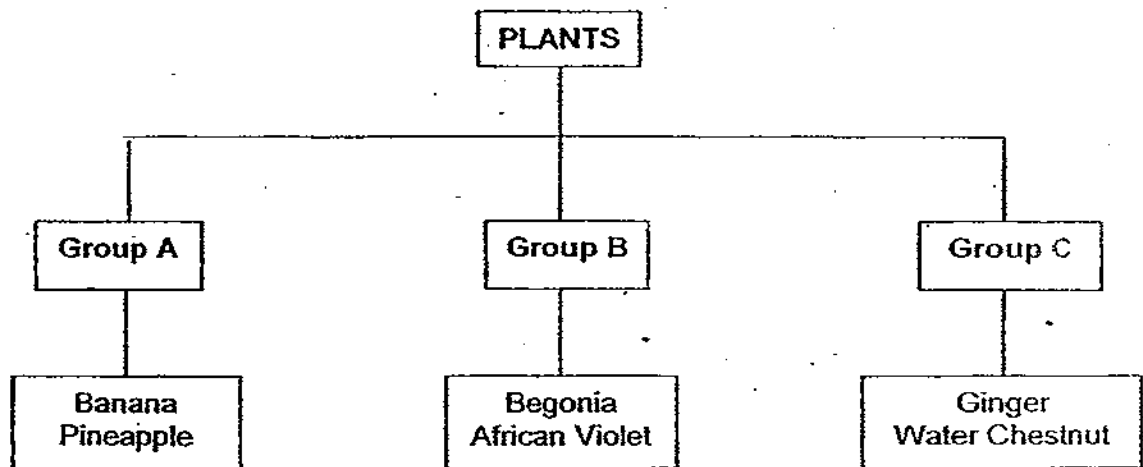

Which one of the following lists shows the correct headings for Groups A, B and C?

	Group A	Group B	Group C
(1)	Seeds	Underground stems	Roots
(2)	Leaves	Spores	Suckers
(3)	Suckers	Leaves	Underground stems
(4)	Suckers	Leaves	Roots

2. Study the flow chart below carefully.

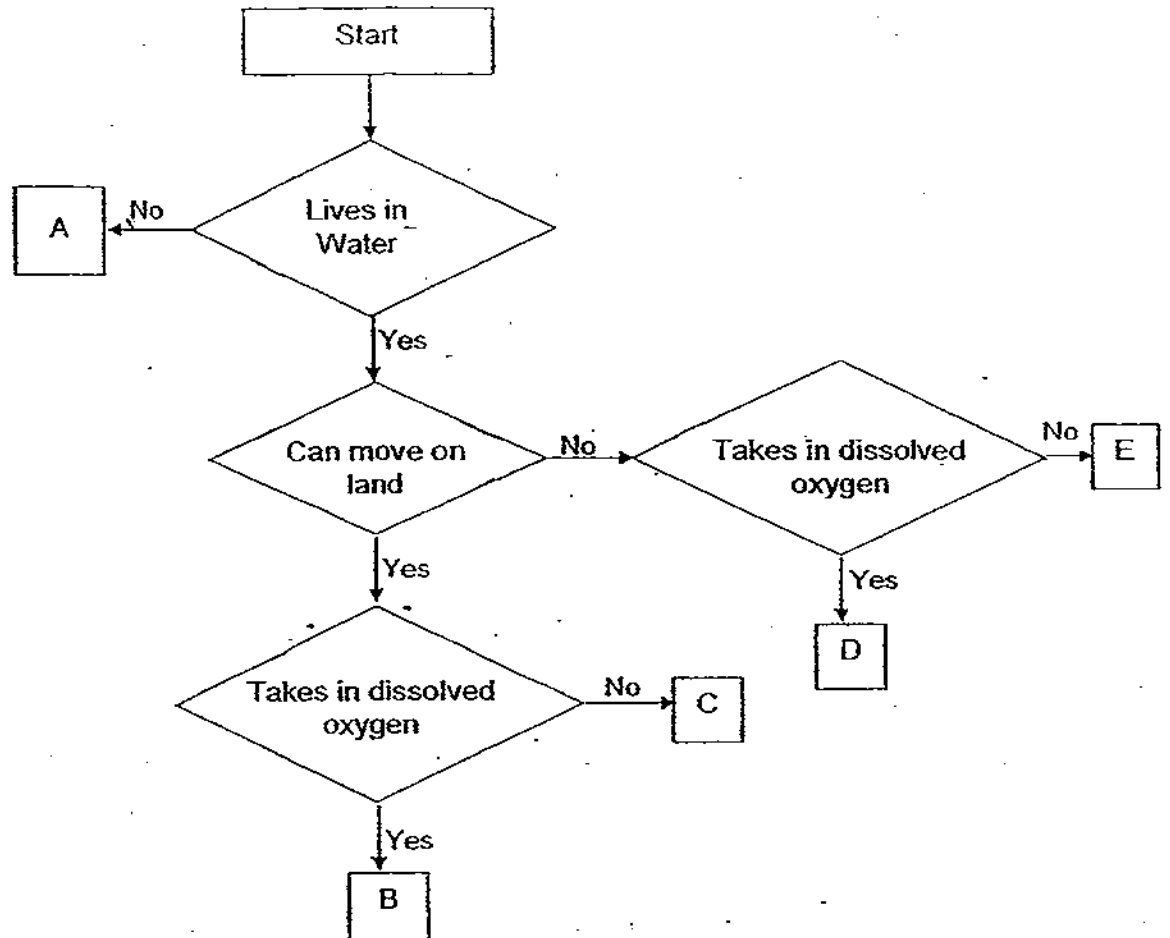

Which set of animals correctly matches the exit points A, B, C, D and E?

	Elephant	Crocodile	Tadpole	Crab	Whale
(1)	D	B	E	A	C
(2)	A	E	B	C	D
(3)	A	C	D	B	E
(4)	E	B	C	A	D

3. Alice releases a pendulum at point Q as shown in the diagram below.

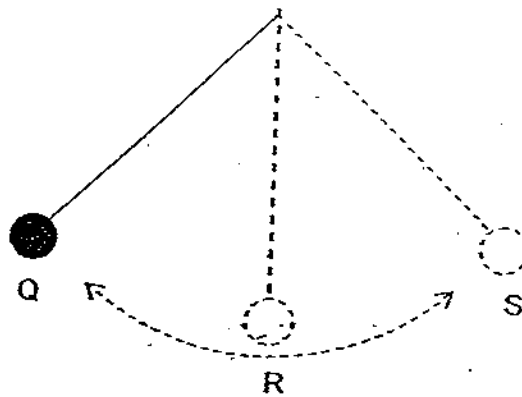

As the pendulum swung from point Q to S, she recorded its kinetic energy and plotted the graph below.

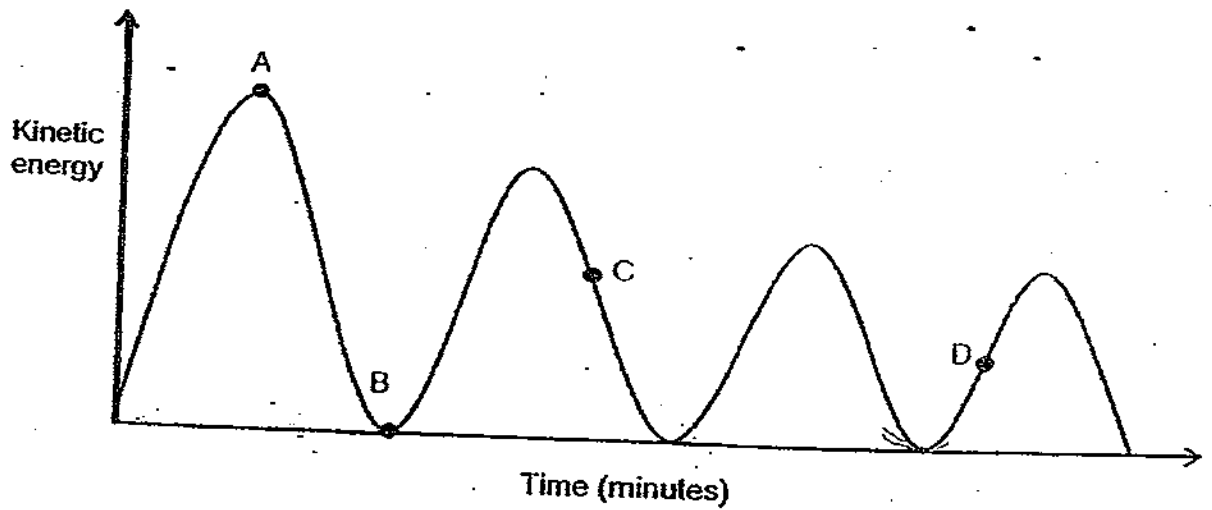

Based on the graph, which point A, B, C or D best represents the kinetic energy of the pendulum when it was at point R?

- (1) A
- (2) B
- (3) C
- (4) D

4. The diagram below shows an athlete doing high jump.

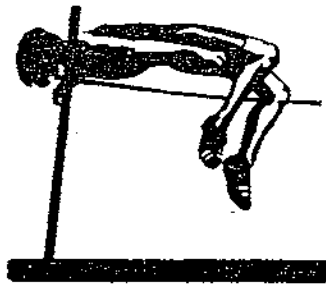

Which one of the following shows the correct energy conversion from the point the athlete was preparing for the jump until the point when she had just crossed the bar?

- (1)

Chemical Potential Energy	→	Kinetic Energy
---------------------------	---	----------------
- (2)

Gravitational Potential Energy	→	Kinetic Energy
--------------------------------	---	----------------
- (3)

Chemical Potential Energy	→	Kinetic Energy	→	Gravitational Potential Energy
---------------------------	---	----------------	---	--------------------------------
- (4)

Gravitational Potential Energy	→	Kinetic Energy	→	Chemical Potential Energy
--------------------------------	---	----------------	---	---------------------------

5. Sharifah held a magnet close to the surface of Material X. She observed that some nails immediately attached themselves onto the other side of the surface of Material X as shown in the diagram below.

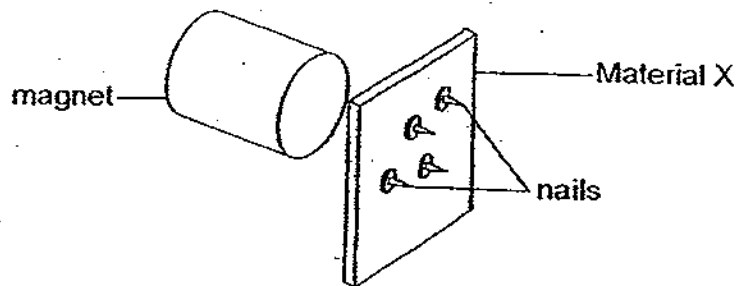

Which of the following could Material X most likely be made of?

- (1) Iron
 - (2) Steel
 - (3) Nickel
 - (4) Copper
6. Study the diagram below carefully.

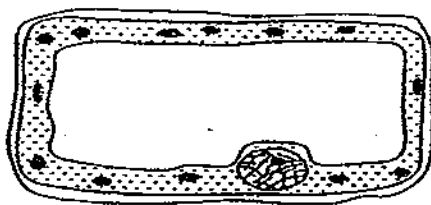

Cell A

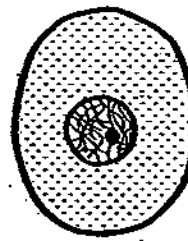

Cell B

Which of the following statements are true about the two cells above?

- A Both cells carry hereditary traits.
 - B Both cells go through cell division.
 - C Both cells have cytoplasm and cell membrane
 - ~~D Both cells have cell membrane, cell wall and chloroplasts.~~
- (1) A and B only
 - (2) C and D only
 - (3) A, B and C only
 - (4) A, B, C and D

7. The diagram below shows a battery operated musical box. When the lid is opened, a ballerina doll in the musical box would twirl.

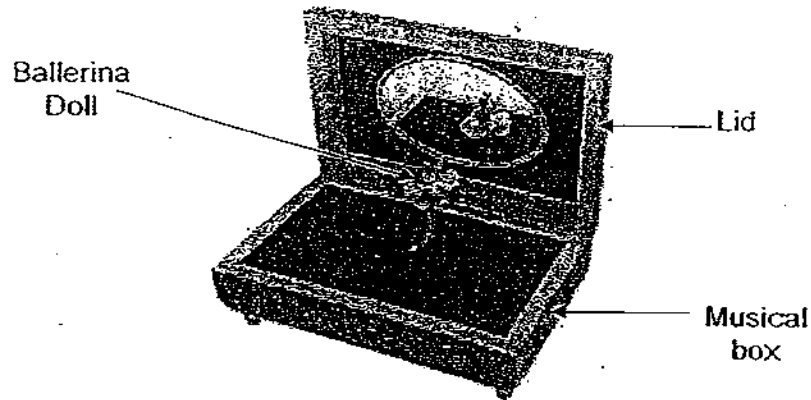

Which one of the following best describes the energy conversion when the box is opened?

- (1) Potential Energy \longrightarrow Sound Energy
 - (2) Potential Energy \longrightarrow Kinetic Energy
 - (3) Potential Energy \longrightarrow Kinetic Energy + Sound Energy
 - (4) Potential Energy \longrightarrow Kinetic Energy + Sound Energy + Potential Energy
8. The energy conversion shown below is most likely to be found in a/an

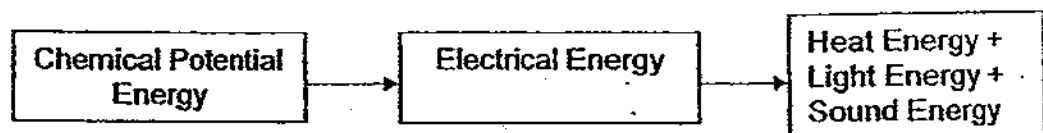

- (1) dynamo
- (2) calculator
- (3) electric iron
- (4) laptop computer

9. Study the flower below carefully.

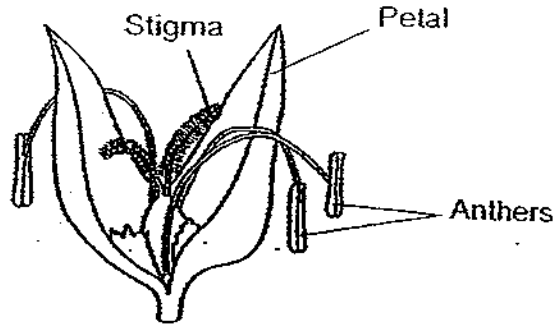

Which one of the following statements can you infer about the flower above?

- (1) The flower has brightly coloured petals.
- (2) The flower bears a fruit with many seeds.
- (3) The pollen grains of the flower are carried by wind.
- (4) The pollen grains of the flower are carried by animals.

10. The following predator-prey relationships were observed among four living things W, X, Y and Z.

W is eaten by Z
 W feeds on Y
 Z feeds on Y but not X
 Y gets its food from X

Which one of the following is the correct classification of the living things?

	Food producer	Prey	Prey/Predator	Predator
(1)	Y	X	Z	W
(2)	X	Y	W	Z
(3)	Z	Y	W	X
(4)	X	Z	Y	W

11. The graph below shows the effect of temperature on the populations of 4 different organisms; A, B, C and D.

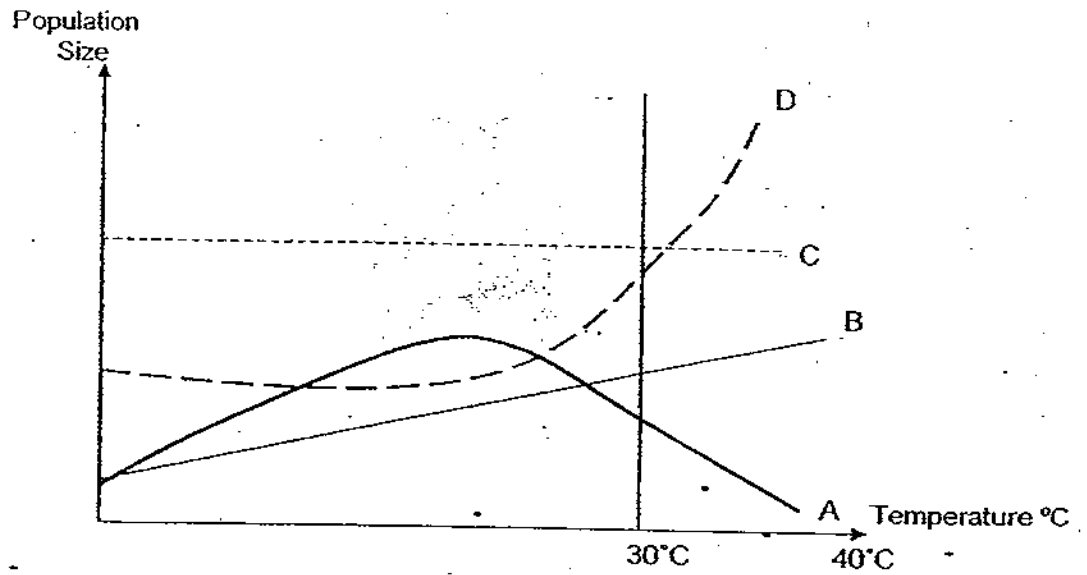

Which organism(s) will not thrive if the temperature of the environment is around 38°C?

- (1) A only
- (2) C only
- (3) C and D only
- (4) A, B and C only

12. Organism W is very sensitive to air pollution. The graph shows how the distance from a factory affects the number of organism W.

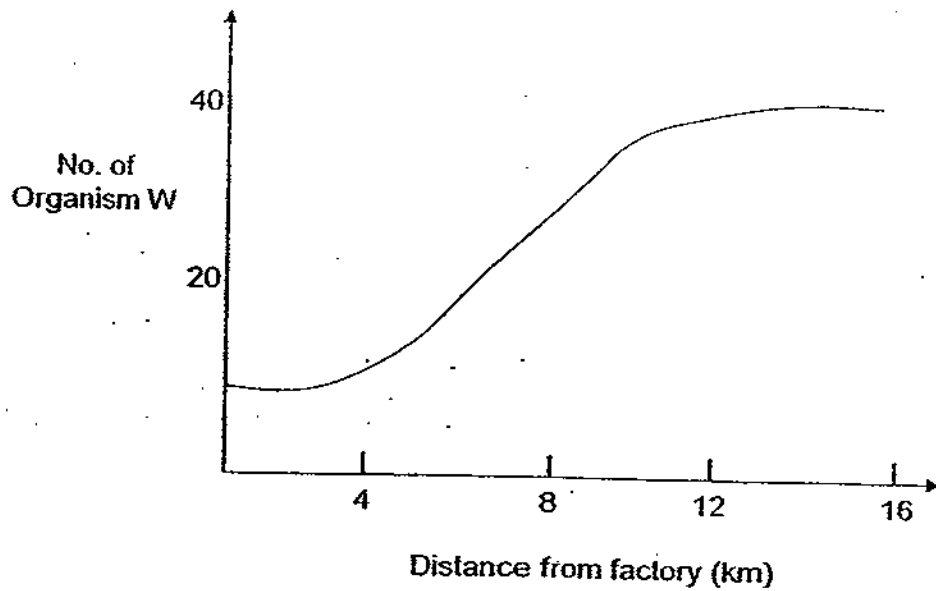

Which one of the following conclusions can be drawn from the graph?

- (1) Organism W grows more quickly near the factory.
- (2) The number of organism W increases as the distance from the factory decreases.
- (3) The number of organism W decreases as the distance from the factory increases.
- (4) The number of organism W increases as the distance from the factory increases.

13. An experiment was carried out to find out if the surface area of a wooden block in contact with the table affects the amount of effort needed to move it. The experiment was performed with apparatus as shown in set-ups X and Y.

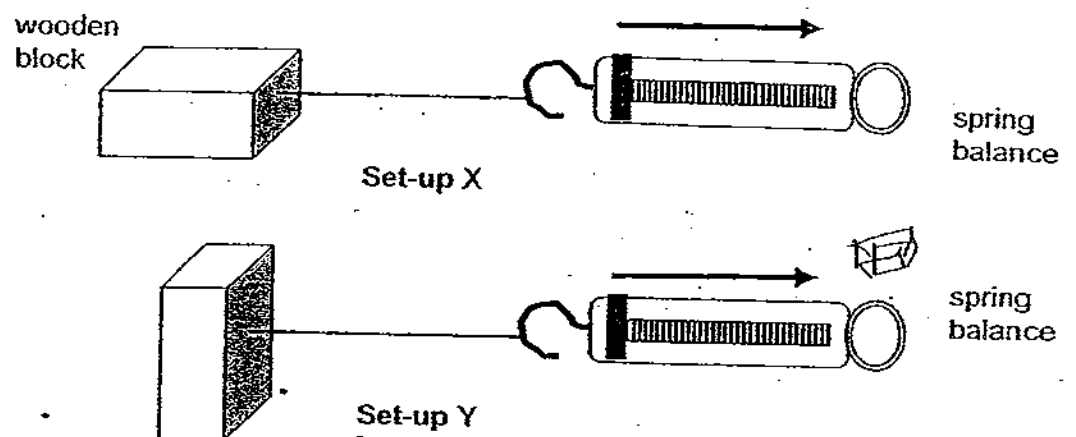

The amount of effort (N) used to move the same wooden block in both set-ups are shown in the table.

	1 st Try (N)	2 nd Try (N)	3 rd Try (N)	Average (N)
Setup X	0.63	0.64	0.66	0.643
Setup Y	0.63	0.64	0.65	0.64

Based on the results, what conclusion could be drawn?

- (1) The heavier the wooden block is, the greater the friction produced.
- (2) There was less friction produced with a smaller surface area in contact with the table.
- (3) There was more friction produced with a larger surface area in contact with the table.
- (4) The size of the surface area in contact with the table had no or insignificant effect on the amount of friction produced.

14. Jayan carried out an experiment to determine the effects of objects of different masses on a spring. A line graph was plotted as shown below after the experiment.

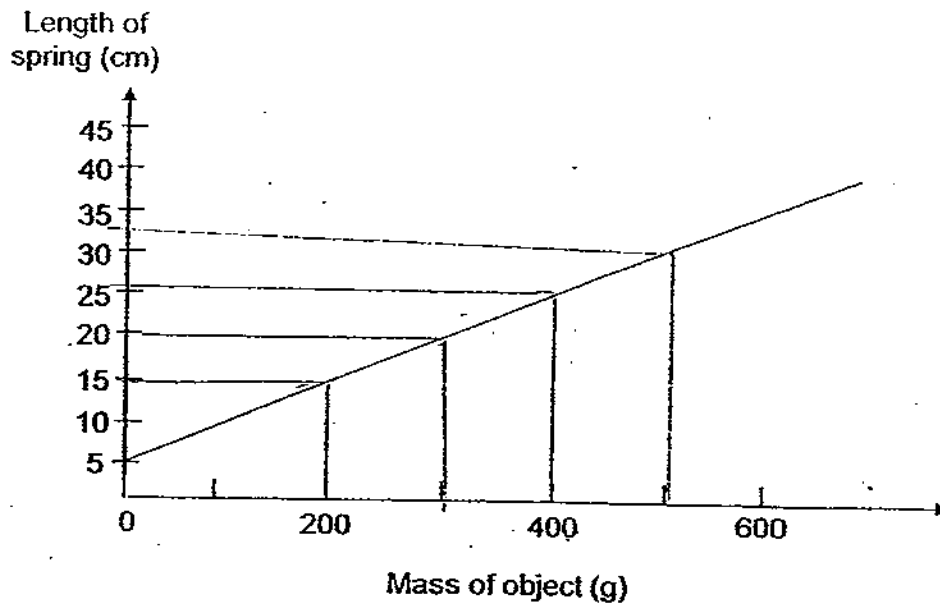

What can Jayan conclude from the line graph above?

- A The length of the spring increases as more mass is hung on the spring.
- B When the mass increases by twice, the length of the spring will also increase by twice.
- C When a 500g object is hung on the spring, the length of the spring is 40cm.
- D The extension of the spring is 15cm when a 300g object is hung on it.

- (1) A only
- (2) A and D only
- (3) B and C only
- (4) A, B, C and D

15. Study the food web below.

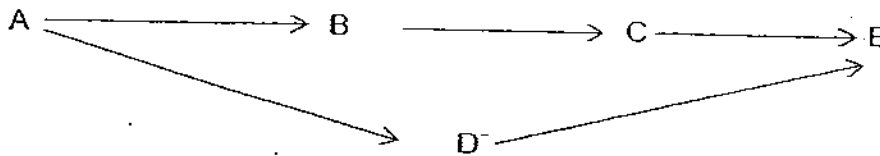

Which one of the following shows the changes in the populations of organisms B, C and D if the population of E decreases?

	Population of B	Population of C	Population of D
(1)	Increases	Decreases	Decreases
(2)	Decreases	Increases	Remains the same
(3)	Increases	Increases	Decreases
(4)	Decreases	Increases	Increases

16. The food web below shows the inter-relationships among some organisms.

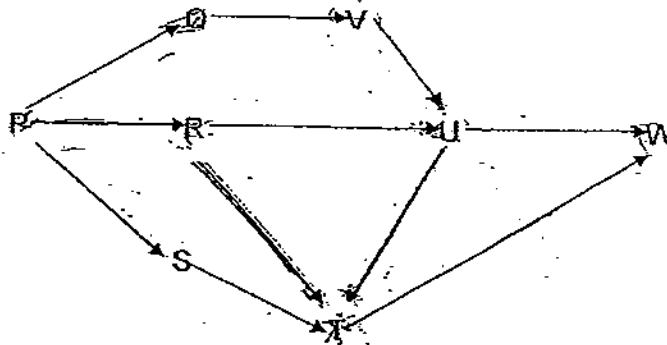

Based on the food web above, which of the following statements are true?

- A Q is an omnivore.
- B There are four predators
- C There are three herbivores.
- D More than four food chains can be formed.

- ~~(1) A, B and C only~~
- ~~(2) A, C and D only~~
- ~~(3) B, C and D only~~
- ~~(4) A, B, C and D~~

17. The table below shows the boiling point and freezing point of some substances.

Substance	Boiling point ($^{\circ}\text{C}$)	Freezing point ($^{\circ}\text{C}$)
P	55	-2
Q	62	-10
R	75	-15
S	90	-30

Based on the table above, which of the following statements are true about the substances?

- A Substance P is in solid state at 10°C .
- B Substance S is in liquid state at 85°C .
- C Both substances Q and R are in gaseous state at 62°C .
- D All the four substances will be in liquid state at room temperature.

- (1) ~~A and B only~~
- (2) ~~A and C only~~
- (3) ~~B and D only~~
- (4) C and D only

18. The diagram below shows a top view of an underground tunnel.

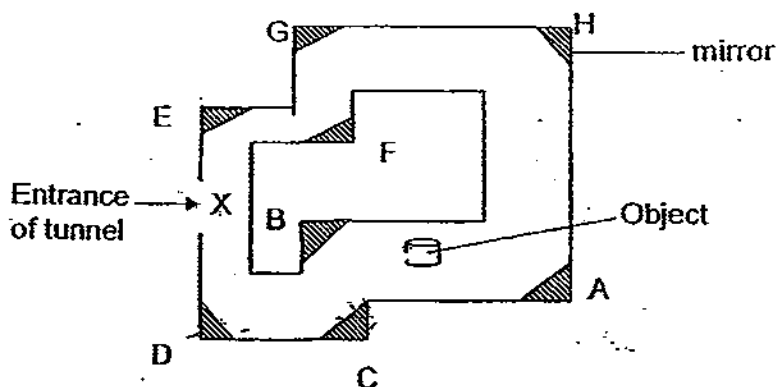

There were mirrors at the corners of the tunnel. Which mirror(s) would enable a person standing at point X to see the object in the tunnel?

- (1) A, B and C only
- (2) B, C and D only
- (3) D, E and G only
- (4) E, F, G and H only

19. Three different types of plants, X, Y and Z were identified on some empty plot of land as shown in Figure 1. All of them bore fruits. A few years later, as a result of dispersal, more of the plants were found as shown in figure 2.

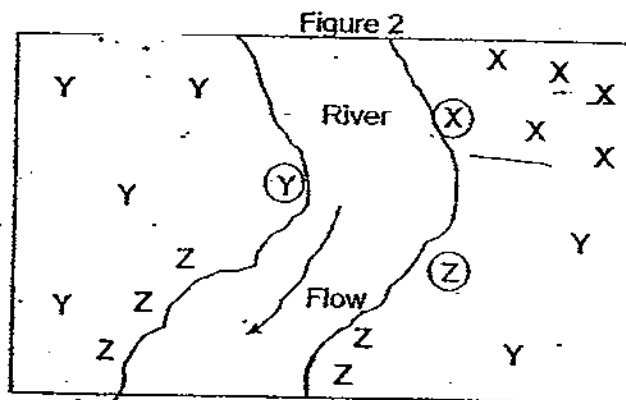
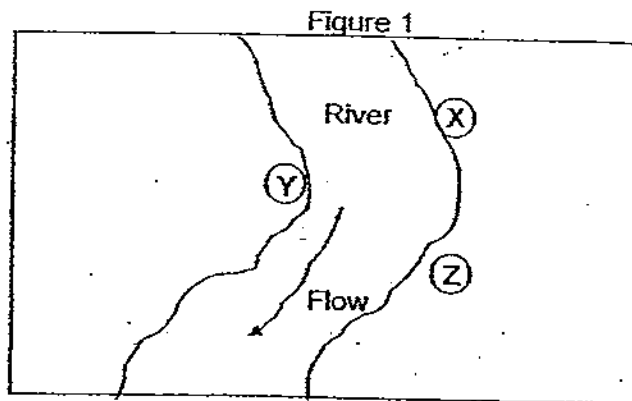

Based on the observation from figure 2, what are the likely characteristics of the fruits of plants X, Y and Z, which helped them to disperse their seeds?

	Plant X	Plant Y	Plant Z
(1)	Has a water-proof outer covering	Has air spaces	Has thorns
(2)	Splits open when dry	Is hairy and light	Has a fibrous husk
(3)	Has wing-like structures	Is fleshy and edible	Has a water-proof outer covering
(4)	Is fleshy and edible	Splits open when dry	Has hook-like structure

20. Rosalie used a gear system which consisted of Gear Y and Gear Z to determine the relationship between the number of turns of the two gears. She recorded her observations in the table shown below

	No. of turns		
Gear Y	1	2	3
Gear Z	1.5	3	4.5

Which one of the following observations is true?

- (1) There are 10 teeth in Gear Y and 10 teeth in Gear Z.
- (2) There are 20 teeth in Gear Y and 30 teeth in Gear Z.
- (3) There are 30 teeth in Gear Y and 20 teeth in Gear Z.
- (4) There are 30 teeth in Gear Y and 45 teeth in Gear Z.

21. The diagram below shows how an amoeba reproduces by dividing itself into two.

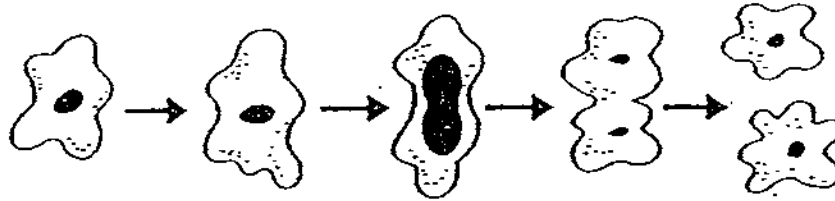

The table below shows the number of amoebae produced after each division.

Division	Number of amoebae
1 st	2
2 nd	4
3 rd	8
?	128

At which division would a total of 128 amoebae be produced?

- (1) 5th
- (2) 6th
- (3) 7th
- (4) 8th

22. The diagram below shows parts of our digestive system.

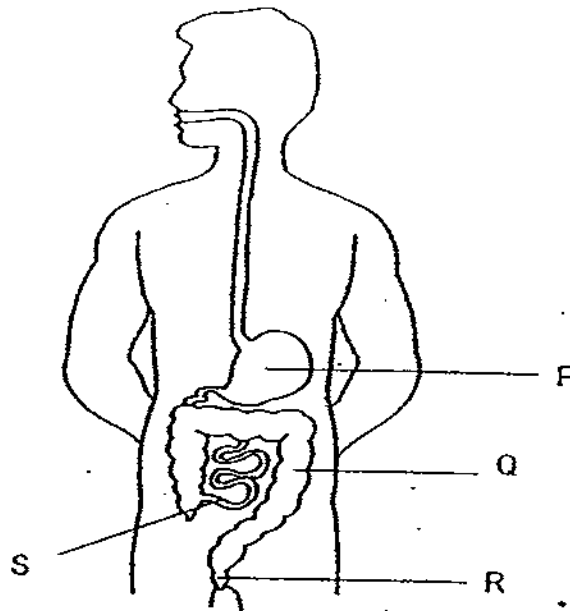

The following statements A, B, C and D, describe the activities that take place at the various parts of our digestive system:

- A Solid waste can be passed out here.
- B Digested food enters the blood from here.
- C A mixture of water and undigested matter is found here.
- D The swallowed food and liquid can remain here for about two to three hours.

Which one of the following sets correctly matches the activities to the parts of the digestive system, P, Q, R and S?

	Part P	Part Q	Part R	Part S
(1)	C	A	D	B
(2)	D	C	A	B
(3)	D	B	A	C
(4)	C	D	A	B

23. The table below provides information to identify Organism S and Organism T.

Description	Organism S	Organism T
Lays eggs	Yes	Yes
Its young resembles its parents	No	No
Number of stages in a life-cycle	4	3
Method of fertilization	Internal	External

Which of the following animals in the table below best identify organisms S and T?

	Organism S	Organism T
(1)	Butterfly	Peacock
(2)	Dragonfly	Cow
(3)	Cockroach	Crow
(4)	Mosquito	Frog

24. Two identical containers with equal amount of water at different temperatures are left in the room as shown below. The room temperature is 27°C .

Room temperature: 27°C

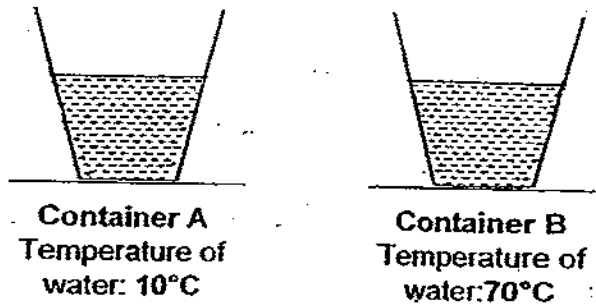

Which one of the following statements describes what would happen to both containers after they are left in the room for 20 minutes?

- (1) Both containers will gain heat.
- (2) Both containers will lose heat.
- (3) Container A will gain heat while Container B will lose heat until both reach the room temperature.
- (4) Container A will lose heat while Container B will gain heat until both reach the room temperature.

25. Edward set up an experiment as shown below. He placed a test tube containing some water into a beaker of mixture of ice and salt. After five minutes, the water in the test tube froze and turned into ice.

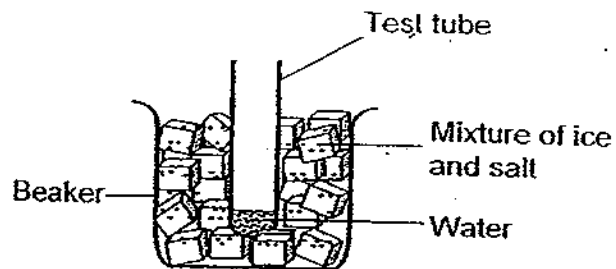

Which one of the following statements best explains what has happened to the water in the test tube?

- (1) The water in the test tube evaporated and turned into ice.
- (2) Heat travelled from the water to the mixture of salt and ice.
- (3) Heat travelled from the mixture of ice and salt to the water in the test tube.
- (4) The water in the test tube gained heat from its surrounding and turned into ice.

26. Study the circuit given below carefully.

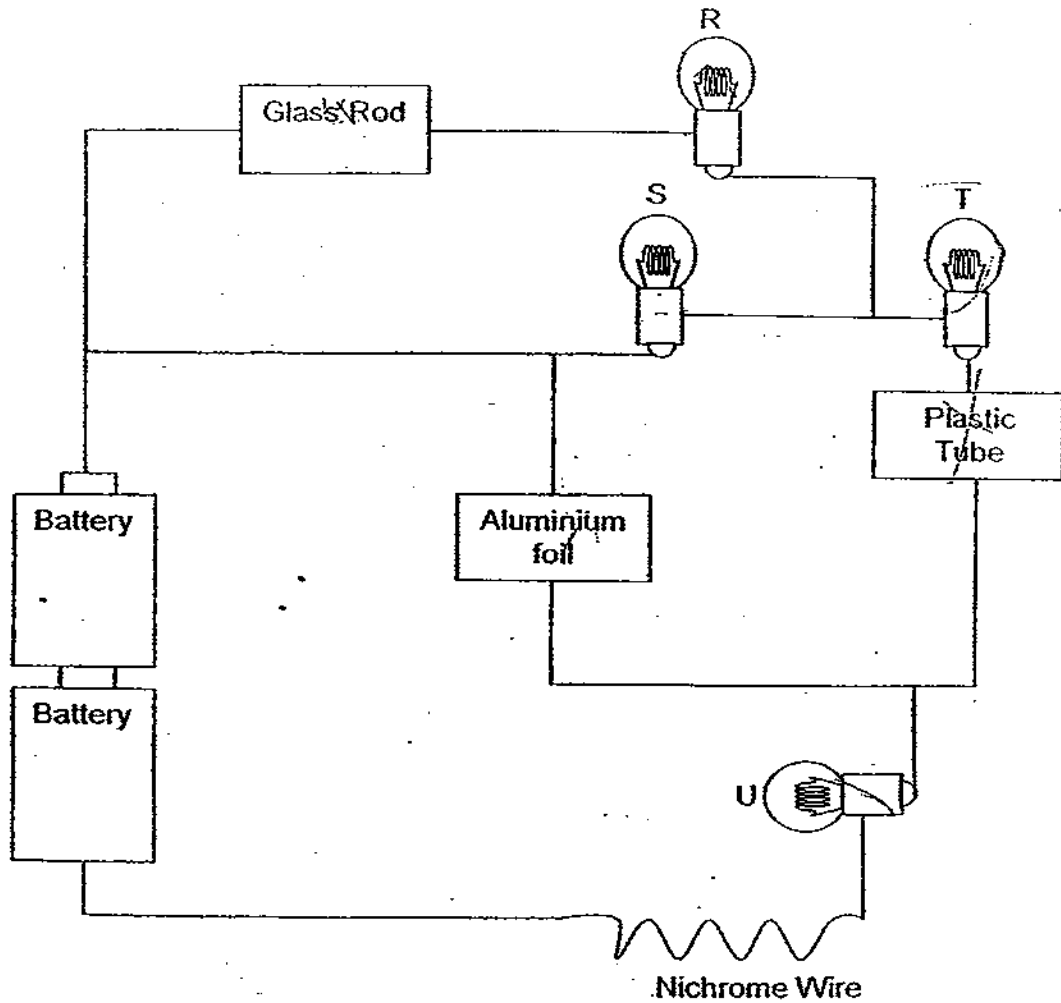

Which bulb(s) will light up?

- (1) Bulb U only
- (2) Bulbs S and U only
- (3) Bulbs R, S and T only
- (4) Bulbs R, S, T and U

27. Kamal set up an electrical circuit shown below.

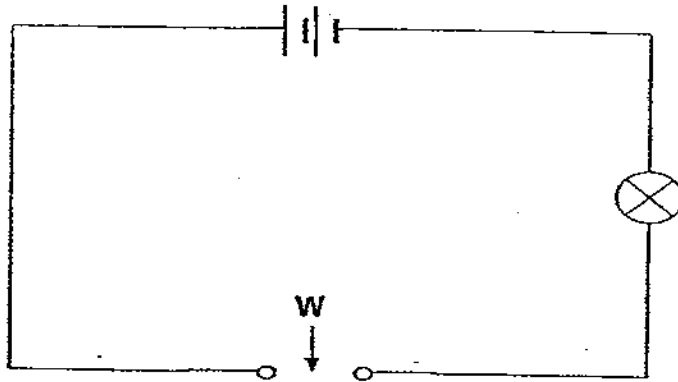

In the circuit above, objects A, B, C and D are connected to the circuit one at a time at W.

The observations made are recorded in the table below.

Object	Is the bulb lighted?
A	Yes
B	No
C	Yes
D	No

Which one of the following could objects A, B, C and D be?

	A	B	C	D
(1)	Copper	Gold	Fabric	Carbon
(2)	Fabric	Copper	Gold	Rubber
(3)	Gold	Rubber	Glass	Carbon
(4)	Carbon	Fabric	Copper	Glass

28. Sulin conducted an investigation on 3 types of simple machines and the results were recorded in the table below.

Simple machine	Load (g)	Effort (g)	Distance travelled by the load (cm)	Distance travelled by the effort (cm)
E	80	110	20	15
F	100	50	10	20
G	110	140	18	12

Which of the simple machine(s) E, F or G use(s) the same principle as a steering wheel?

- (1) E only
 (2) F only
 (3) E and F only
 (4) E and G only

29. The diagram below shows the picture of a platypus and an eagle.



Which of the following statements are true about both animals?

- A: Both have three-stage lifecycle.
 B: Both animals go through internal fertilisation.
 C: Platypus gives birth to young while the eagle lays egg.
 D: Platypus provides the young with milk while the eagle does not.

- (1) ~~A and B only~~
 (2) ~~B and C only~~
 (3) ~~A, B and D only~~
 (4) ~~B, C and D only~~

30. The diagrams below show a straightened arm and a flexed arm.

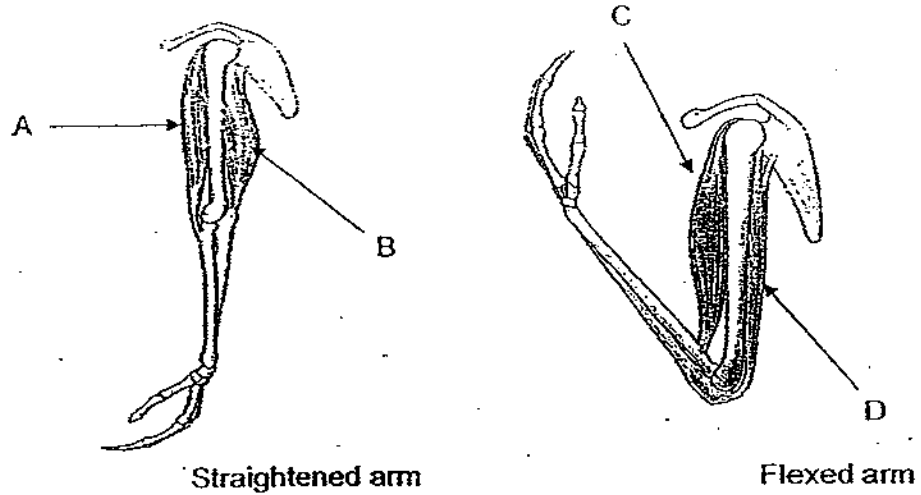

Which one of the following correctly shows the contraction and relaxation of the muscles, A, B, C and D?

	A	B	C	D
(1)	Contract	Relax	Relax	Contract
(2)	Relax	Contract	Contract	Relax
(3)	Contract	Contract	Relax	Relax
(4)	Relax	Relax	Contract	Contract

***** END OF SECTION A *****

Name : _____ ()

Class : Primary 6 _____

CHIJ ST NICHOLAS GIRLS' SCHOOL



Primary 6
Semestral Assessment 1 – 2009
SCIENCE
BOOKLET B
14th May 2009

Total Time for Booklets A and B: 1 hour 45 minutes
This Booklet consists of 17 printed pages.

16 questions
40 marks

Booklet A	60
Booklet B	40
Total	100

Parent's Signature/Date

Do not open this booklet until you are told to do so.
Follow all instructions carefully.

Section B: 40 marks

For questions 31 to 46, write your answers in this booklet.

The number of marks available is shown in the brackets [] at the end of each question or part question.

31. The diagram below shows a simplified hydro-electric power station.

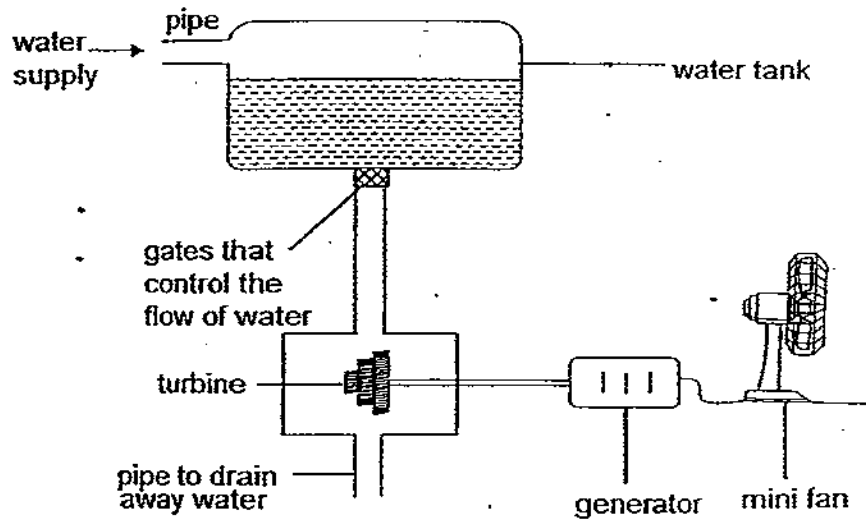

(a) What happens when the gates are opened? [1]

(b) Complete the energy conversion that took place in order for the fan blades to turn. [2]

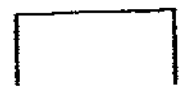
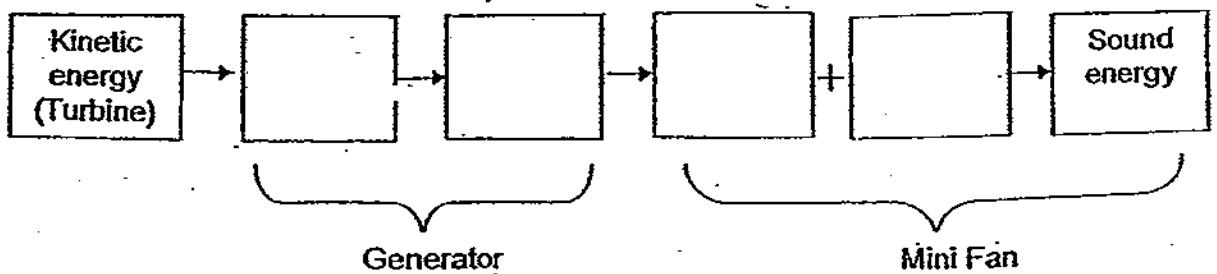

32. In a Carrom competition, Laurent flicked his striker disc at Point A to hit the carrom disc. The path taken by the carrom disc was illustrated in the diagram below.

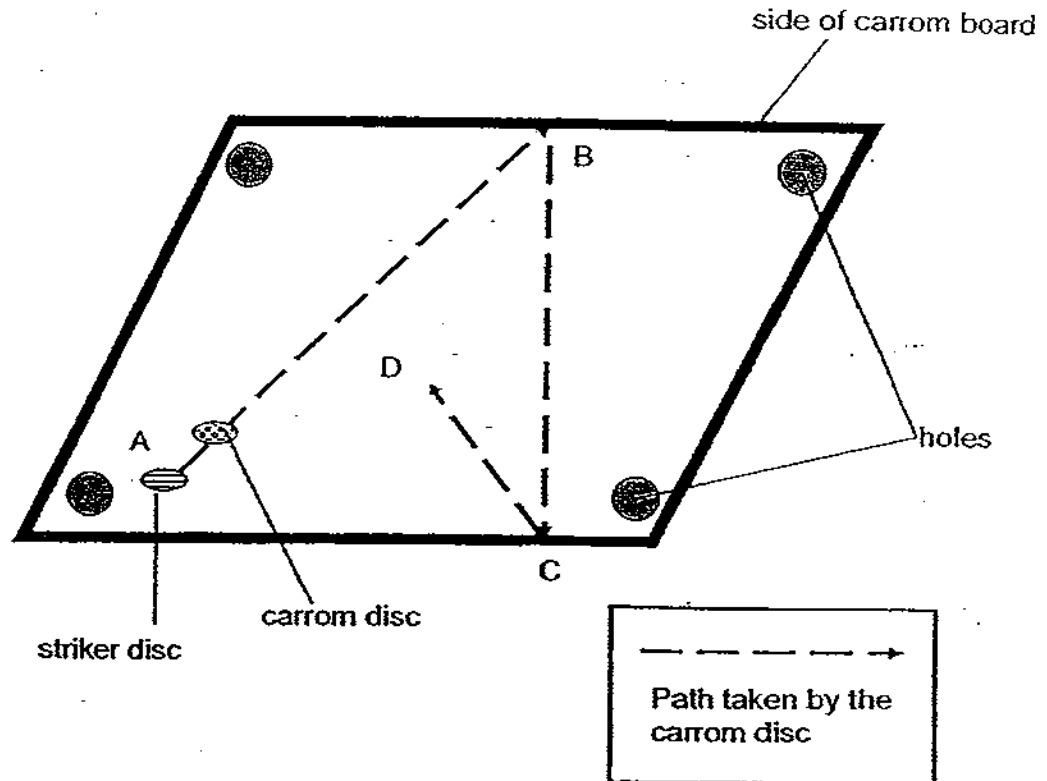

- (a) State the form(s) of energy the carrom disc possessed as it was travelling from B to C. [1]

- (b) How would the energy of the carrom disc be affected if Laurent sprinkled some baby powder on the carrom board? [1]

- (c) Explain your answer in (b). [1]

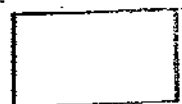

33. The classification table below shows a table of animal groupings.

Animals			
Group W	Group X	Group Y	Group Z
Lion Whale Seal	Ladybird Butterfly Spider	Crocodile Lizard Snake	Seahorse Guppy Goldfish

- (a) Identify the animal that has been classified wrongly in the classification table above. [½]

- (b) Explain why the animal in (a) is classified wrongly. [1]

- (c) Write an appropriate heading for animals in Group W. [½]

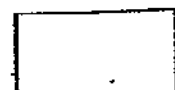

34. The table below shows some objects.

feather duster	woolen sweater	leather belt
eraser	rattan chair	cotton wool

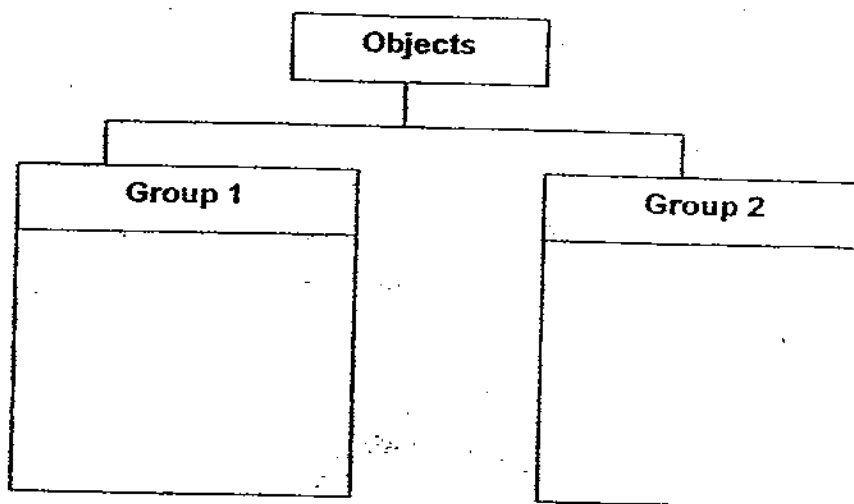

- (a) Classify the objects into two groups such that there are three objects in each group. [3]
- (b) Give a heading for each group. [1]

Group 1: _____

Group 2: _____

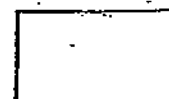

35. Esme set up an experiment as shown below to test how much water each soil samples could hold. She poured equal amount of water into each funnel of soil.

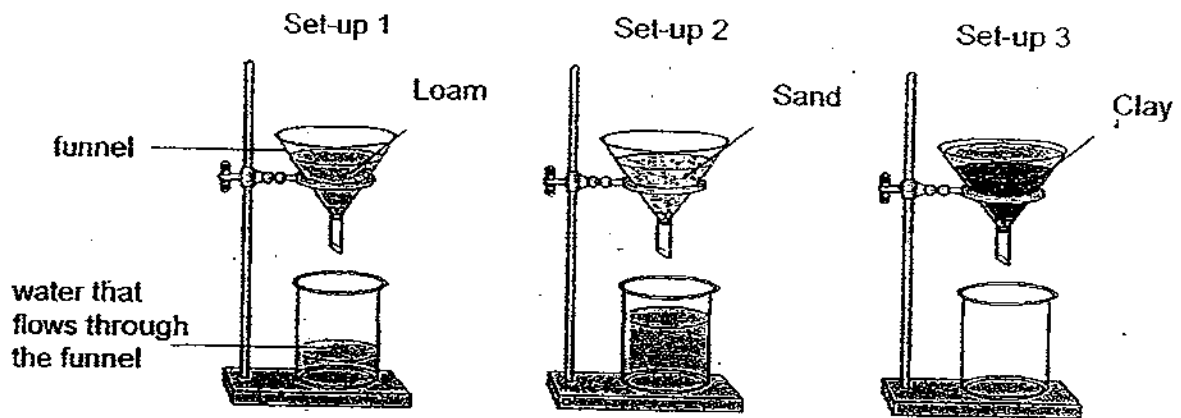

- (a) Based on the set-ups above, which type of soil would a cactus not grow well in? [1]

- (b) Explain your answer in (a). [2]



36. Some chestnuts were placed on two metal woks and cooked under a strong flame as shown in the diagram below.

In set-up B, the chestnuts are cooked with some sand.

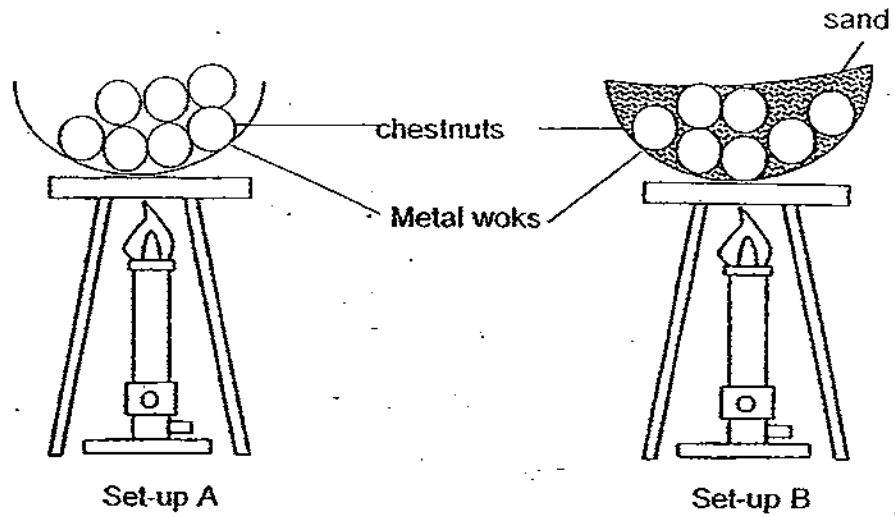

- (a) In which of the above set-ups would the chestnuts be cooked in a shorter period of time? [1]

- (b) Explain your answer in (a). [1]

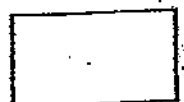

37. Garret wrapped identical ice blocks with different types of materials to test which material would prevent the ice blocks from melting quickly. He recorded the time taken for each ice block to melt.

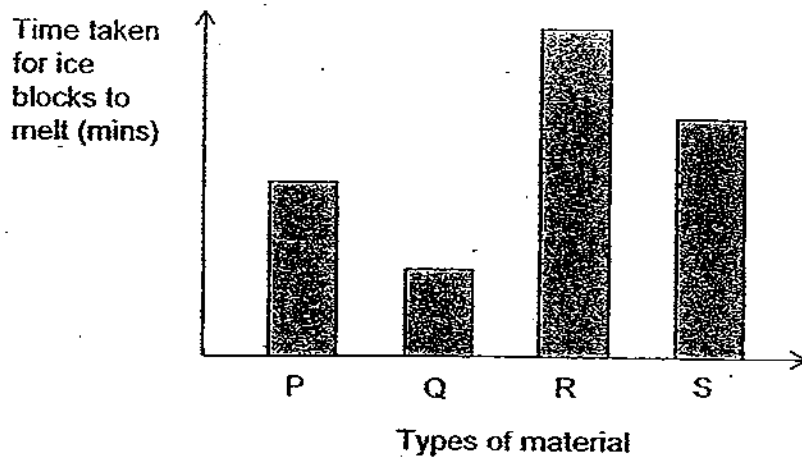

- (a) Based on the above graph, which material is most suitable for making a container that allows him to transport the ice from his home to the beach on a hot day? [½]

- (b) Explain your answer in (a). [1]

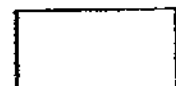

38. Vanessa dropped an Angsana Fruit X from a certain height and recorded the time it took to land on the ground.

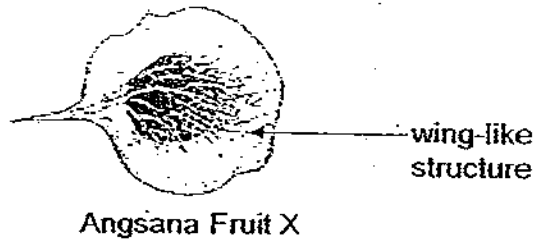

She then took another Angsana Fruit Y and cut the wing-like structure off. She repeated the same experiment with the 'wing-less' angsana fruit.

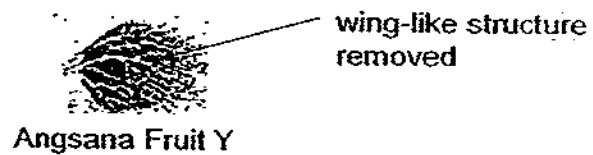

She recorded her readings in the table below.

Results	Time taken for the fruit to land (sec)		
	1 st Try	2 nd Try	3 rd Try
A	5.2	5.4	5.3
B	3.6	3.4	3.5

- (a) Which set of the results, A or B, was recorded when the fruit with the wing-like structure was used? [1]

- (b) Explain your answer in (a). [1]



39. The diagram below shows the greatest distance at which the magnets will attract paper clips A and B. Paper clip A is twice as heavy as paper clip B.

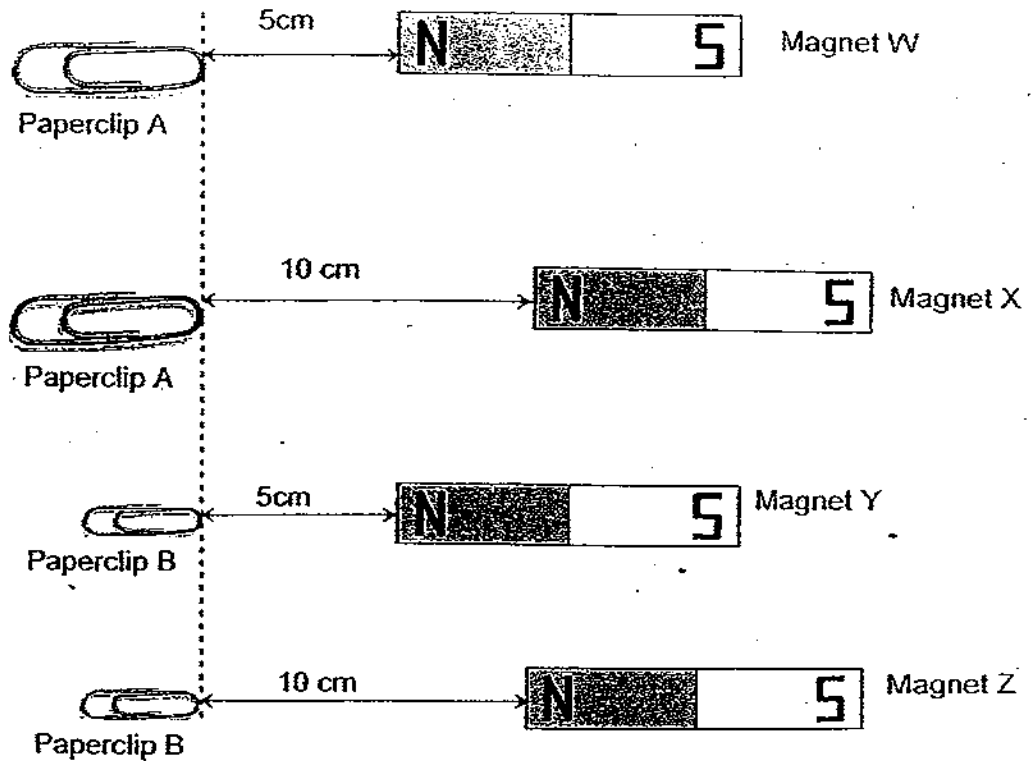

- (a) Based on the results above, which magnet, W, X, Y or Z is the strongest? [1]

- (b) Explain your answer in part (a). [1]

- (c) Based on the set up, why is it unfair to compare the strengths of magnets W and Z? [1]

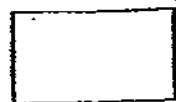

40. Sulaiman tries to drill two different screws, X and Y into a wooden slab using the same screwdriver. The numbers in the brackets show the number of treads the screwdriver has.

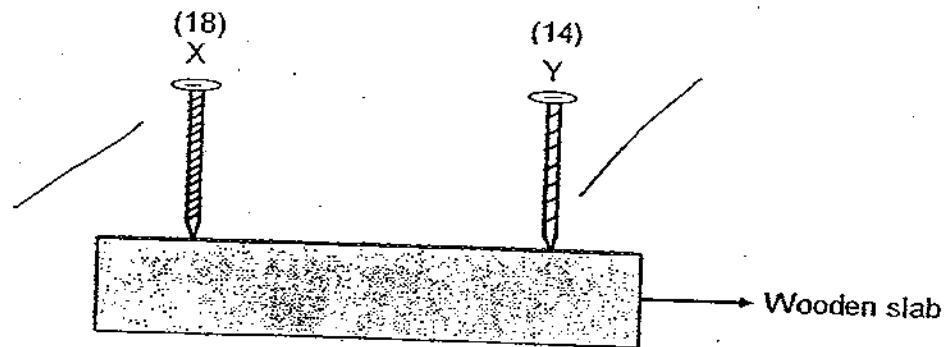

- (a) Which nail, X or Y, will it be easier for Sulaiman to drill into the wooden slab? [½]

- (b) Explain your answer in (a). [1]

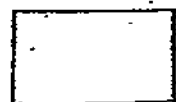

41. The rose plants in Mrs Loo's garden are infested with a type of aphids. She was advised to grow some Plant Q in her garden as this will keep the aphids away. Before she does so, Mrs Loo wants to find out if this is true.

(a) In the space below, draw two set-ups that Mrs Loo can set up in order to conduct a fair test. In your diagram, use the symbols shown below.

[2]

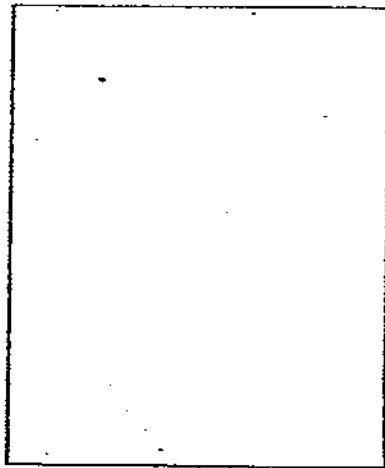
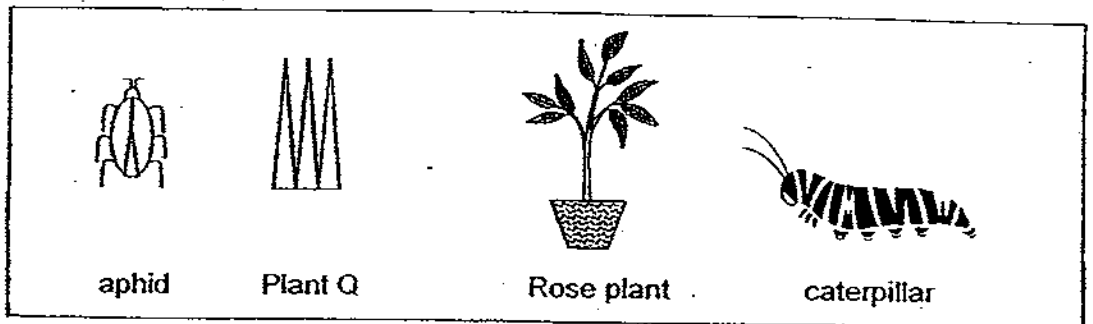

Set-up 1

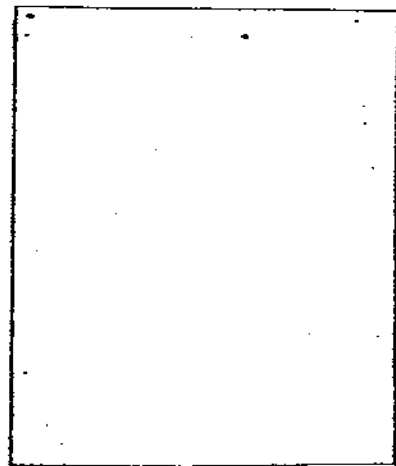

Set-up 2

(b) What should Mrs Loo be observing in the experiment?

[1]

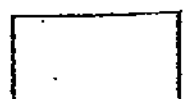

42. Study the diagram below.

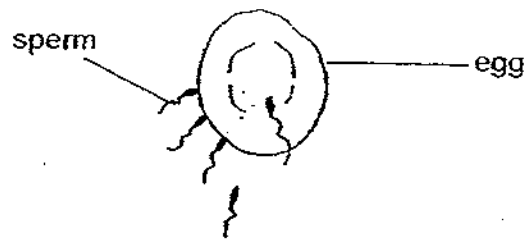

(a) Name the process shown above. [½]

(b) Explain what happens when the process takes place. [1]

(c) Label in the diagram below where this process will occur [½]

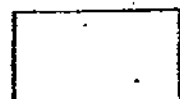

43. Elina sets up two different circuits and plots the amount of light the bulb produces in the graphs below. The graphs show the relationship between the number of batteries and the brightness of the bulb in Circuit A and Circuit B respectively.

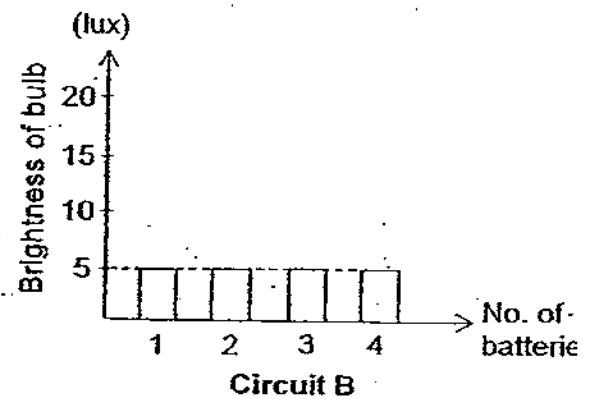
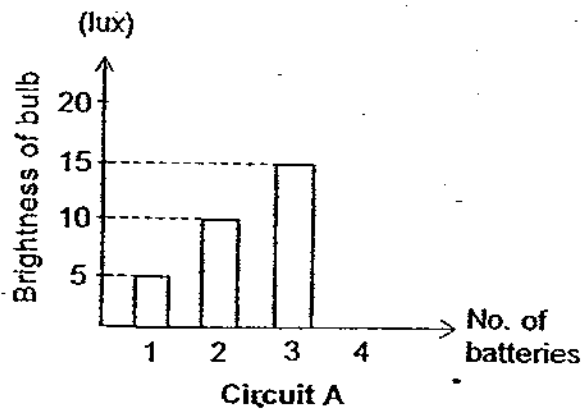

- (a) Based on the above graphs, what is the arrangement of the batteries in each of the circuits? [1]

(i) Circuit A: _____

(ii) Circuit B: _____

- (b) Explain your answer in (a) in relation to the number of batteries and the brightness of the bulb for both circuits. [2]

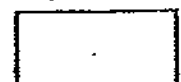

44. Study the phases of the moon below.

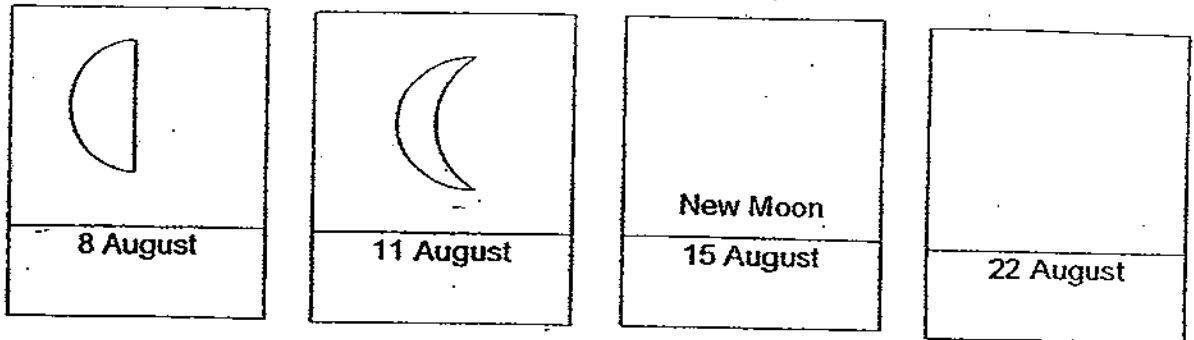

(a) Draw the phase of the moon that you will see on 22nd August. [1]

(b) On what date will you be able to see the full moon? [1]

45. Study the flow chart below carefully.

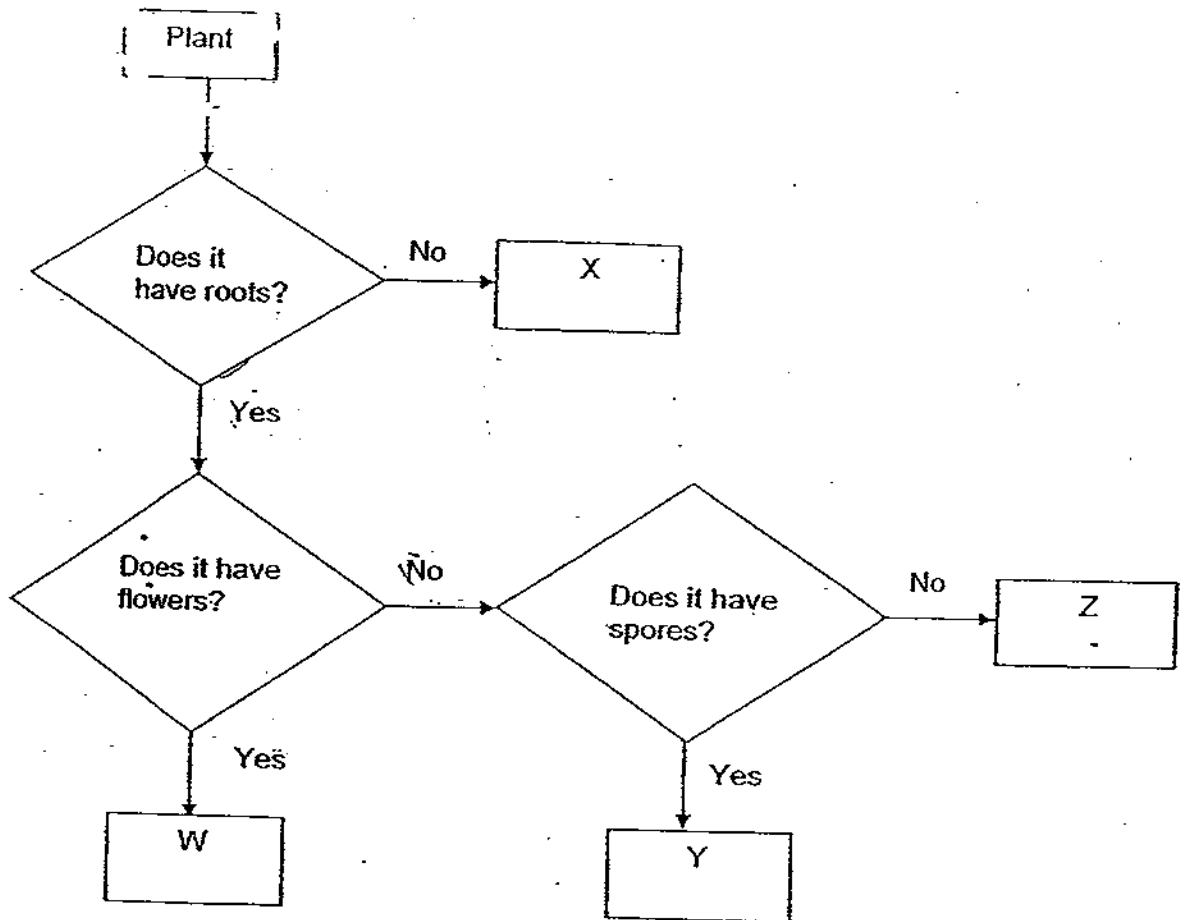

(a) What are the similarities between Y and Z? [1]

(b) Which exit point W, X, Y or Z would you place 'Casuarina'? [1]

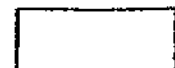

46. Sophia wanted to find out if the rate of photosynthesis of Elodea would be affected by the intensity of light. She put the same type of plant into three containers and placed each of them at different distances from three similar table lamps in a dark room for an hour.

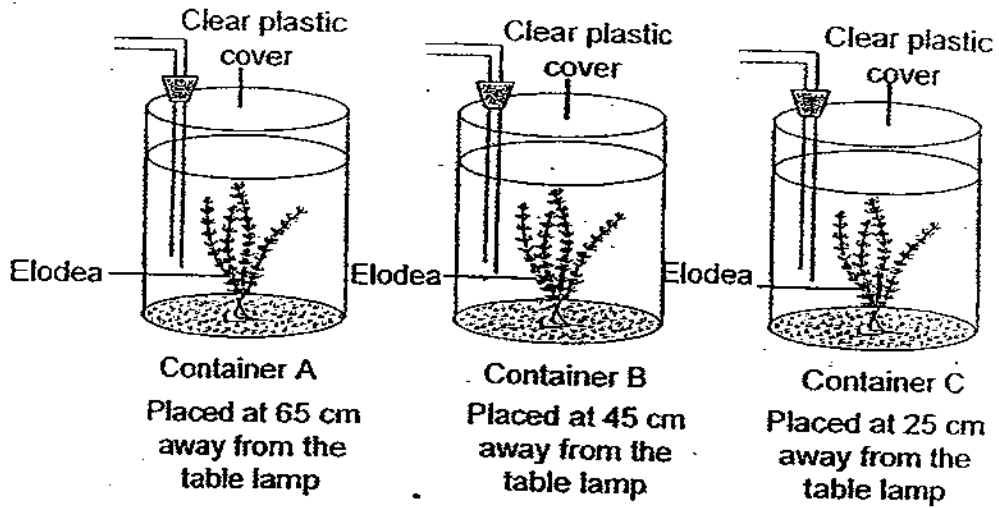

She recorded the number of air bubbles produced at 5 minutes intervals for 1 hour and plotted the graph below to show the results for the elodea in container B.

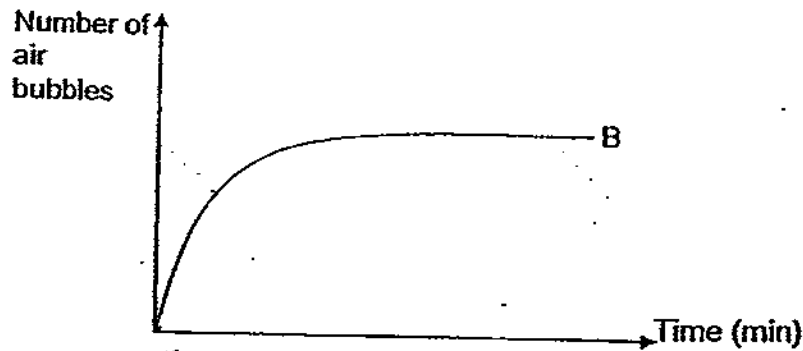

- (a) Using the same graph above, complete the graph above to show the results for the plants in containers A and C respectively. (You must label your graph.) [2]
- (b) Based on the results in (a), what is the relationship between the distance of the lamp from the plants and the rate of photosynthesis? [1]

End of Paper

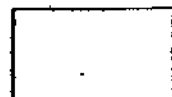

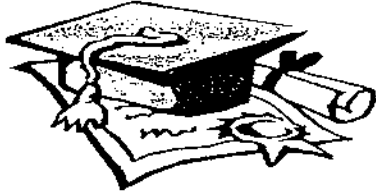

ANSWER SHEET

EXAM PAPER 2009

SCHOOL : CHIJ PRIMARY

SUBJECT : PRIMARY 6 SCIENCE

TERM : SA1

Q1	Q2	Q3	Q4	Q5	Q6	Q7	Q8	Q9	Q10	Q11	Q12	Q13	Q14	Q15	Q16	Q17
3	3	1	3	4	3	3	4	3	2	1	4	4	2	4	3	3

Q18	Q19	Q20	Q21	Q22	Q23	Q24	Q25	Q26	Q27	Q28	Q29	Q30
2	3	3	3	2	4	3	2	1	4	2	3	2

31)a)The water will flow and turn the turbines.

b)Kinetic energy→Electrical energy→Kinetic energy + Heat energy

32)a)Kinetic energy.

b)The energy of the carrom disc would be greater.

c)The baby powder acts as a lubricant and reduces friction and allows the carrom disc to travel faster.

33)a)spider.

b)Spider has eight legs and therefore is not classified with insects which only has six legs.

c)Mammals.

34)a)1)eraser, rattan chair, cotton wool

2)feather duster, woolen sweater, leather belt

b)1)Made from plants.

2)Made from animals.

35)a)Clay.

b)Clay does not allow water to drip into the beaker which indicates that it does not allow water drip to sip through easily.

36)a)Set-up B.

b)In set-up B, the sand would also gain heat from the flame and heat up the chestnuts too, thus causing it to heat up faster than set-up A.

37)a)R.

b)The ice wrapper with material R melts the slowest as it is the poorest conductor of heat.

38)a)A.

b)The wing-like structure allows the fruit to glide in the air and therefore the time taken for the fruit to land would be longer.

39)a)Magnet X.

b)It can attract paperclip A which is heavier than Paperclip B from the longest distance.

c)The paperclips used are different and Paperclip A is heavier than Paperclip B and more force would be needed to attract Paperclip A than B.

40)a)X.

b)If screws X and Y are unrolled, it will be observed that screw X has a less steeply inclined plane than Y and therefore, X would be easier for Sulaiman to drill into the wooden slab.

41)a)

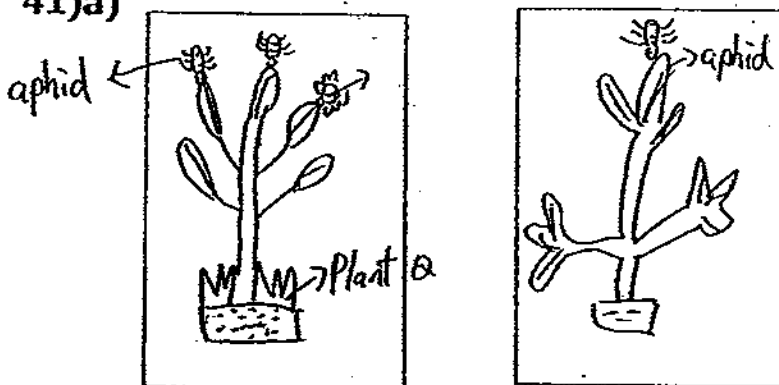

b)The rose plant should have less number of aphids in the set-up that has plant Q.

42)a)Fertilisation.

b)The nucleus of the sperm fuses with the nucleus of the female egg.

c)

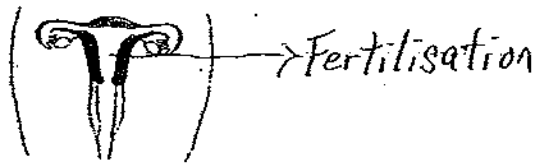

43)a)i)Series arrangement.

ii)Parallel arrangement.

b)In Circuit A, the more batteries there are, the brighter the bulb, until the fourth battery is placed, it does not light up anymore. In Circuit B, the brightness of the bulb remains constant although the number of batteries increases.

44)a) D

b)29th August.

45)a)They are plants, has roots, and do not have flowers.

b)Z.



b)The further the distance between the lamp plants the slower the rate of photosynthesis of the plants.

