



## AI TONG SCHOOL

### 2006 SEMESTRAL ASSESSMENT (1) PRIMARY SIX SCIENCE

**DURATION : 1h 45 min**

**DATE: 11 May 2006**

#### INSTRUCTIONS

**Do not open the booklet until you are told to do so.**

**Follow all instructions.**

**Answer all questions.**

Name : \_\_\_\_\_ ( )

Class : Primary 6 \_\_\_\_\_

Parent's Signature : \_\_\_\_\_

Date : \_\_\_\_\_

Marks :

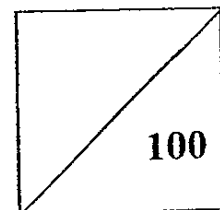

29-30

**Section A ( 30 x 2 marks)**

For each question from 1 to 30, four options are given. One of them is the correct answer. Make your choice (1, 2, 3 or 4). **Shade the correct oval (1, 2, 3 or 4) on the Optical Answer Sheet.**

1. The following chart shows how plants can be classified.

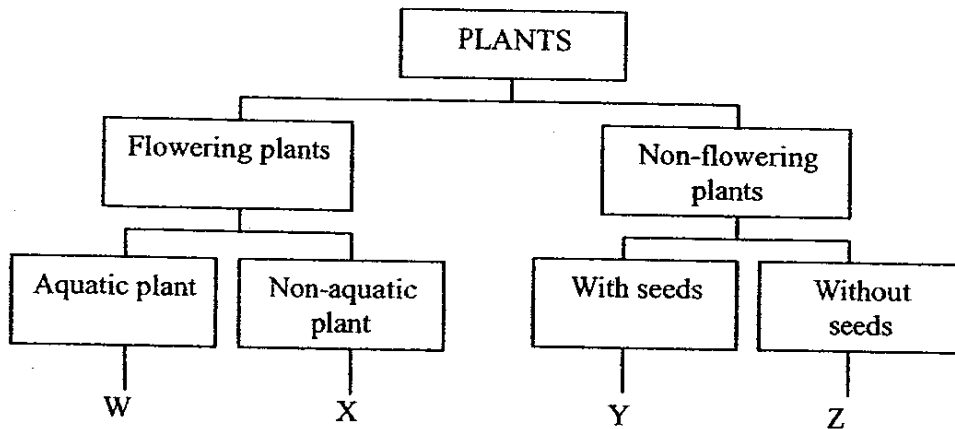

Which one of the following plants is Z?

- (1) Water lily
  - (2) Hibiscus
  - (3) Bird's nest fern
  - (4) Pine
2. Which one of the groups below is classified correctly based on the characteristic 'eat meat only'?
- (1) man, fox and cow.
  - (2) snail, cow and caterpillar.
  - (3) chicken, cat and rabbit.
  - (4) python, shark and tiger

3. The classification chart below shows the properties of four different materials.

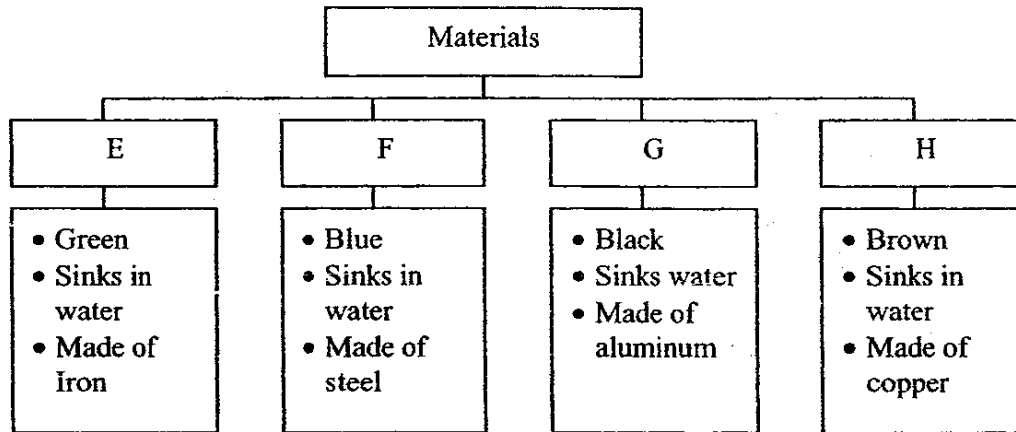

Choose the two materials that can be separated from each other by using a magnet.

- A Materials E and F
- B Materials E and G
- C Materials F and H
- D Materials G and H

- (1) A and B only
- (2) A and C only
- (3) B and C only
- (4) B and D only

4. Four examples of how forces are used are shown below.



Peter drilling on the ground



Mr. Lee writing on the blackboard



Jane climbing up a wall



Mr. Tan painting a wall

How many of the above examples show that friction is useful?

- (1) one
- (2) two
- (3) three
- (4) four

5. The classification chart below shows the different ways to reduce friction.

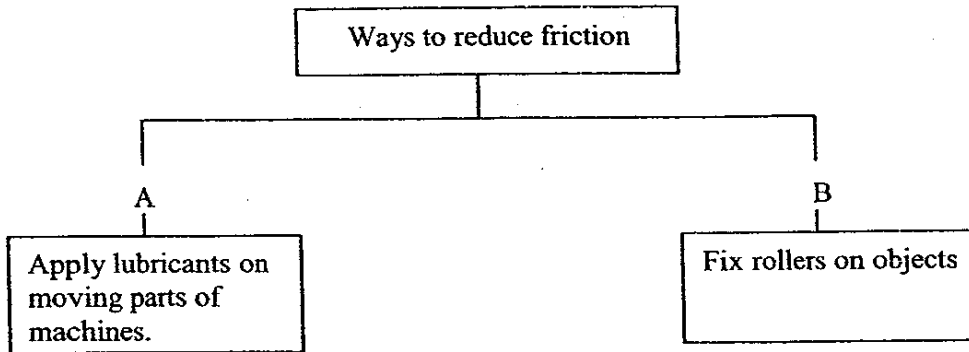

Which of the objects in the table below use the above ways to reduce friction?

	A	B
1.	Skateboard	Track shoes
2.	Sewing machine	Trolley
3.	Cars	Electric drill
4.	Telephone	Spring balance

6. At the Bird Park, a great number of plants are grown. How do the plant and bird populations depend on each other?

- A Plants provide nesting places for some birds.
- B Plants provide shade and shelter for some birds.
- C Birds' droppings provide nutrients for plants.
- D Some birds feed on the plants.

- (1) A, B and C only
- (2) A, C and D only
- (3) B, C and D only
- (4) A, B, C and D

7. Study the information on Plant Y.

- the roots can absorb a lot of water
- the fruit is fibrous
- it requires a lot of sunshine to grow well

Which one of the following habitat is Plant Y most likely to be found?

- (1) seashore
- (2) desert
- (3) leaf litter
- (4) rotting log

8. Which one of the following is a community?

- (1) Tadpoles and toads in a pond.
- (2) Cockroaches, nymphs and eggs in a drawer.
- (3) Butterflies, caterpillars and eggs on a plant.
- (4) Grasshoppers, butterflies and earthworms in a garden.

9. Mei Mei measured the temperature in six different locations in a garden with a datalogger. She also counted the number of plants grown at each of the location. She was trying to find out if the temperature affects the \_\_\_\_\_.

- (1) height of the plants
- (2) rate of the photosynthesis
- (3) survival of plants
- (4) the amount of oxygen in the surroundings

10. Kelvin divided a tray of soil into four parts M, N, O and P. He watered parts M and N and covered parts O and M. He then put two groups of animals at the centre of the tray and left the tray in direct sunlight. After two hours, he counted the number of animals in each group in M, N, O and P and recorded the results in the following table.

Part	Group S	Group T
M	0	12
N	0	0
O	0	0
P	3	0

What can you infer from the results obtained?

- A The animals in Group S prefer bright light.
- B The animals in Group T prefer bright light
- C The animals in Group S prefer a damp place.
- D The animals in Group T prefer a damp place.

- (1) A and D only
- (2) B and C only
- (3) A, B and D only
- (4) A, B, C and D

11. Which one of the following insects will seriously damage plants by spreading plant diseases?

- (1) Centipede
- (2) Earthworm
- (3) Aphid
- (4) Grasshopper

12. During a period of drought, the water in a pond dries up. What would happen to the population of dragonflies near the pond?

- A There will be an increase in population size.
- B There will be a decrease in their population size.
- C The population may move out of the pond area.

- (1) A only
- (2) A and B only
- (3) B and C only
- (4) A, B and C

13. Which of the following statements are true about angsana seeds?

- A It is dispersed by wind.
- B The seed has a wing-like structure.
- C The seed has a waterproof husk.

- (1) A and B only
- (2) B and C only
- (3) A and C only
- (4) A, B and C only

14. The chart below shows the adaptations that some birds have.

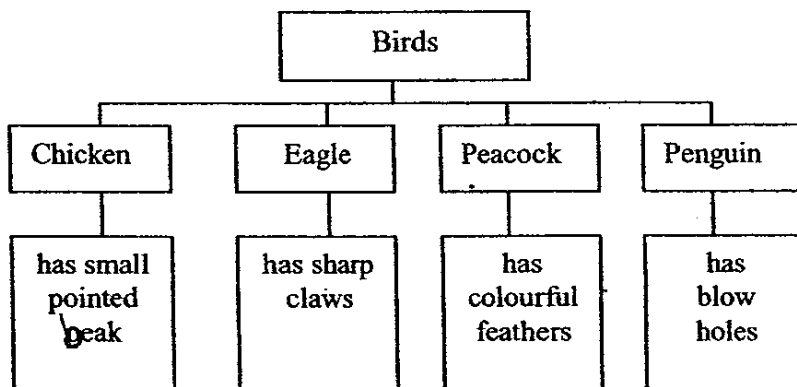

Which bird does **not** use the adaptation mentioned?

- (1) Chicken
- (2) Eagle
- (3) Peacock
- (4) Penguin



15. The following table shows how 4 animals are adapted for breathing in water. Which one is incorrect?

Adaptations for breathing in water	Animals
A. Skin	Tubifex worms
B. Breathing tube	Water spider
C. Nostrils      blowhole	Dolphin
D. Gills	Tadpole

- (1) A
- (2) B
- (3) C
- (4) D

16. Which of the following are adaptations that help plants to **reduce water loss** in a desert?

- A Clasping roots
- B No flowers
- C Needle-like leaves
- D Waxy stems

- (1) A and B only
- (2) B and C only
- (3) C and D only
- (4) B, C and D

17. Philip used a magnifying glass to carry out an experiment on a sunny day as shown below. He managed to get a burn mark on his paper.

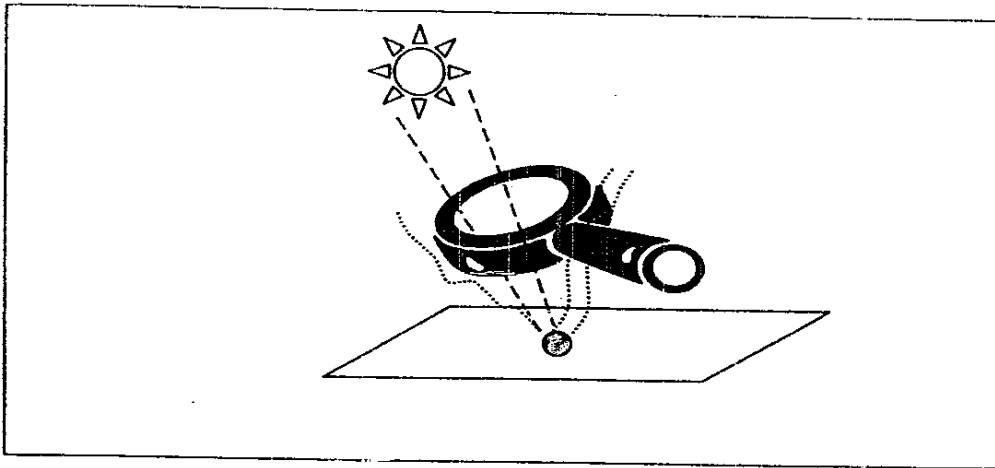

What energy changes took place?

- (1) Solar energy was changed to heat energy.
  - (2) Solar energy was changed to heat and chemical energy.
  - (3) Solar energy was changed to light and heat energy.
  - (4) Solar energy was changed to light and chemical energy.
18. Ben threw a ball into the air, then caught it. Which of the following correctly identifies the energy changes that take place after he has thrown the ball?

	<b>Ball is moving up</b>	<b>At the highest point</b>	<b>Ball is moving downwards</b>
(1)	Kinetic energy is changing to potential energy.	Kinetic energy is zero.	Potential energy is changing to kinetic energy.
(2)	Kinetic energy is maximum.	Kinetic energy is changing to potential energy.	Potential energy is zero.
(3)	Potential energy is changing to kinetic energy.	Potential energy is zero.	Kinetic energy is changing to potential energy.
(4)	Potential energy is maximum.	Potential energy is changing to kinetic energy.	Kinetic energy is zero.

19. It was a windy day. Junyang dropped two shorea fruit, A and B, from the same height as shown in the diagram below:

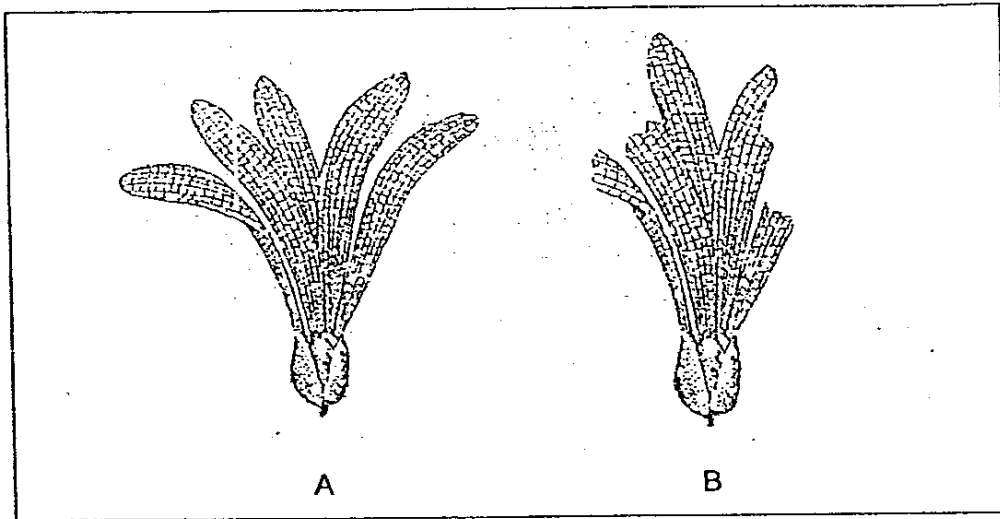

He recorded the time taken by each fruit to reach the ground. Which one is most likely to be the correct set of records?

	A	B
(1)	3.3 s	4.6 s
(2)	4.6 s	4.6 s
(3)	4.6 s	3.3 s
(4)	4.6 s	10.2 s

20. Four drops of liquids, A, B, C and D, of equal size are put on a piece of paper so that each left a mark. A hair-dryer is used to dry them. The observations are recorded in the table below:

A	The mark dries up the fastest.
B	The mark dries up after some time.
C	The mark dries up but leaves behind some white solid.
D	The mark remains.

If the four types of liquid were alcohol, oil, pure water and salt solution, which one of the following shows that the liquids have been correctly identified?

	A	B	C	D
(1)	alcohol	pure water	oil	salt solution
(2)	alcohol	pure water	salt solution	oil
(3)	pure water	salt solution	oil	alcohol
(4)	pure water	salt solution	alcohol	oil

21. Huili carried out an experiment to find out how she could balance 2 loads on rods of different lengths. The diagrams below show the results of 2 of her experiments.

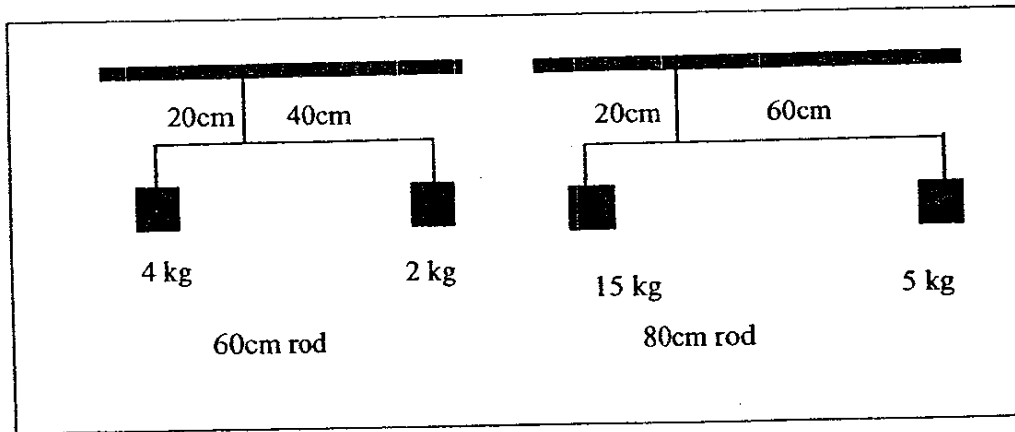

Her third experiment is shown below.

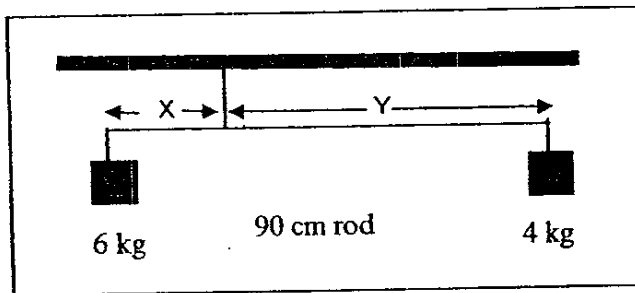

In order for the set of scales to be balanced, the value of X must be \_\_\_\_\_.

- (1) 24 cm
- (2) 36 cm
- (3) 45 cm
- (4) 54 cm

22. Joshua carried out 3 investigations using selected equipment from the list shown below.





Plastic bottle	Notebook and pen	Wooden blocks
Jug with water	Tape measure	Wooden board

Which investigation cannot be carried out?

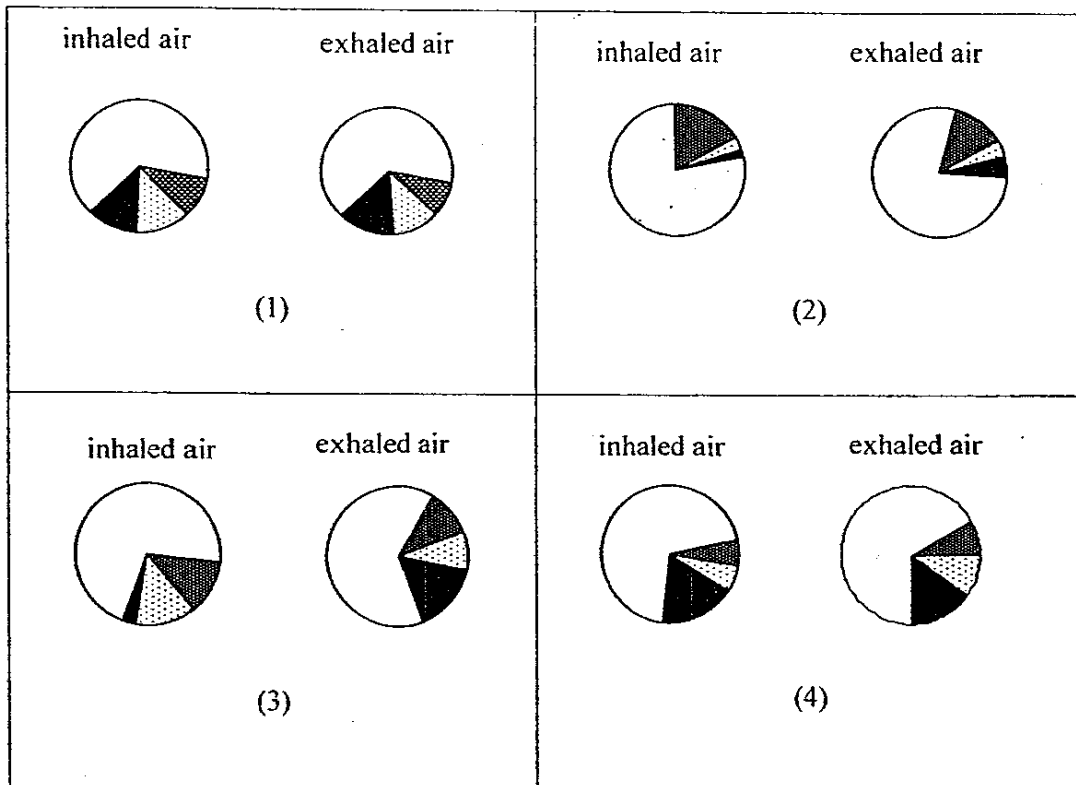
- (1) Does the type of bottle affect how far it will roll?
- (2) Does the amount of water in the bottle affect how far it will roll?
- (3) Does the steepness of the ramp affect how far the bottle will roll?
- (4) Does the wooden board break when supporting a full bottle of water?

23. Which one of the following pairs of charts correctly represents the air we breathe in and out?



			
nitrogen	oxygen	water vapour	carbon dioxide

43

24. An owl slows down as it nears a mouse on the ground, grabs it and then flies up onto a branch to eat it. Ten minutes later, it flies off the branch and returns to its speed before the slow-down. Which graph below best shows how the owl's speed changes with time?

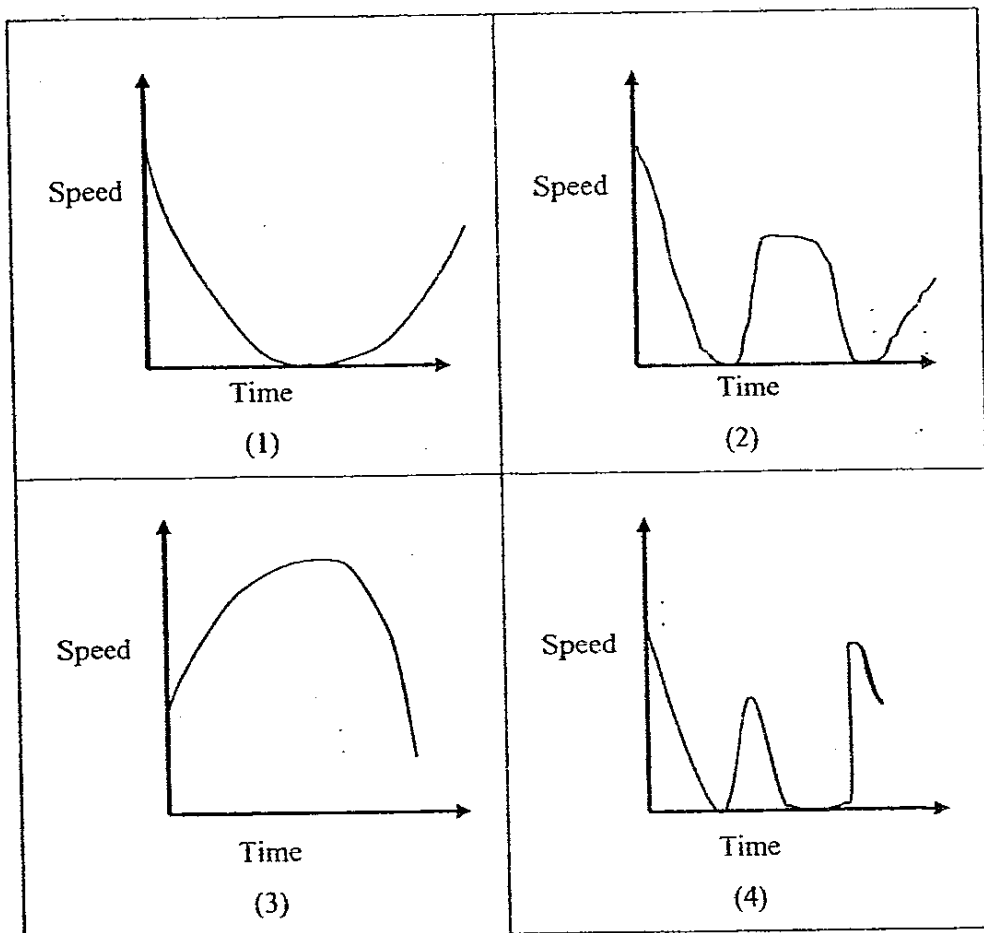

25. An experiment is set up as shown in the diagram.

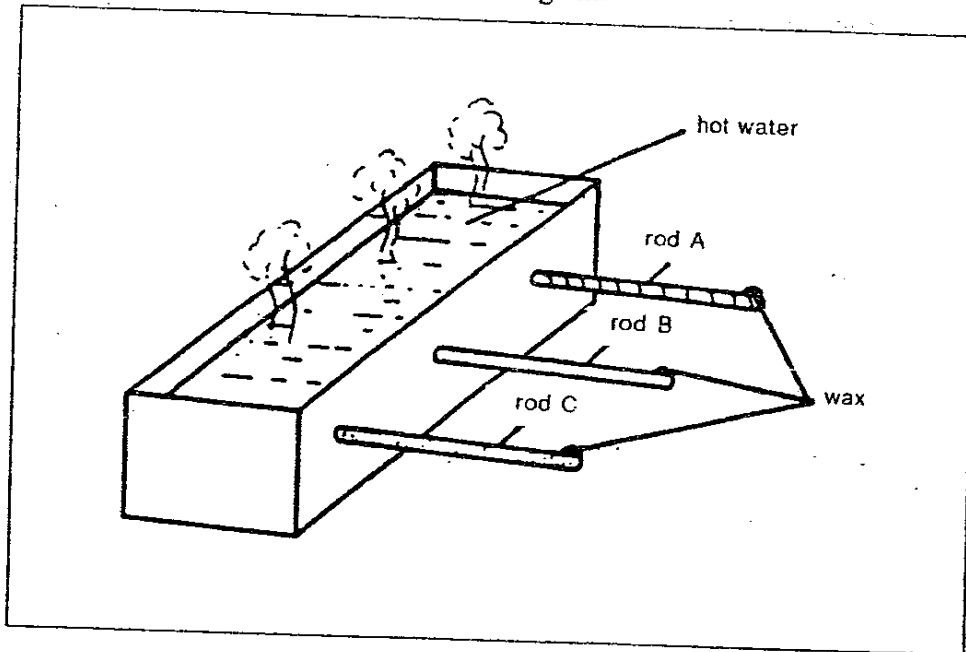

Rods A, B, and C are of the same length but of different materials. Three pieces of wax from a candle are placed at the tip of each rod. It is observed that the wax on A melts first followed by that on B and then C.

Which one of the following statements explains the observation?

- (1) Some materials give off heat more easily than others.
- (2) Some materials conduct heat more easily than others
- (3) Some pieces of wax melt more easily than other pieces.
- (4) Some parts of the water gain heat more easily than other parts.

26. Jack wanted to know which coloured drink was most popular. He sold drinks during a sports carnival and recorded his results as shown.

Type of drink	Number of cups sold
Water	20
Water with red cordial	60
Water with green cordial	55
Water with orange cordial	50

What does **not** have to be kept the same for this experiment to be a fair test?

- (1) The cost of each drink.
- (2) The number of cups sold.
- (3) The flavour of each cordial used.
- (4) The type and size of each cup used.



27. Which of the following graphs shows correctly the predator-prey relationship between the bird and caterpillar populations in the food chain :

leaves  $\longrightarrow$  caterpillar  $\longrightarrow$  bird

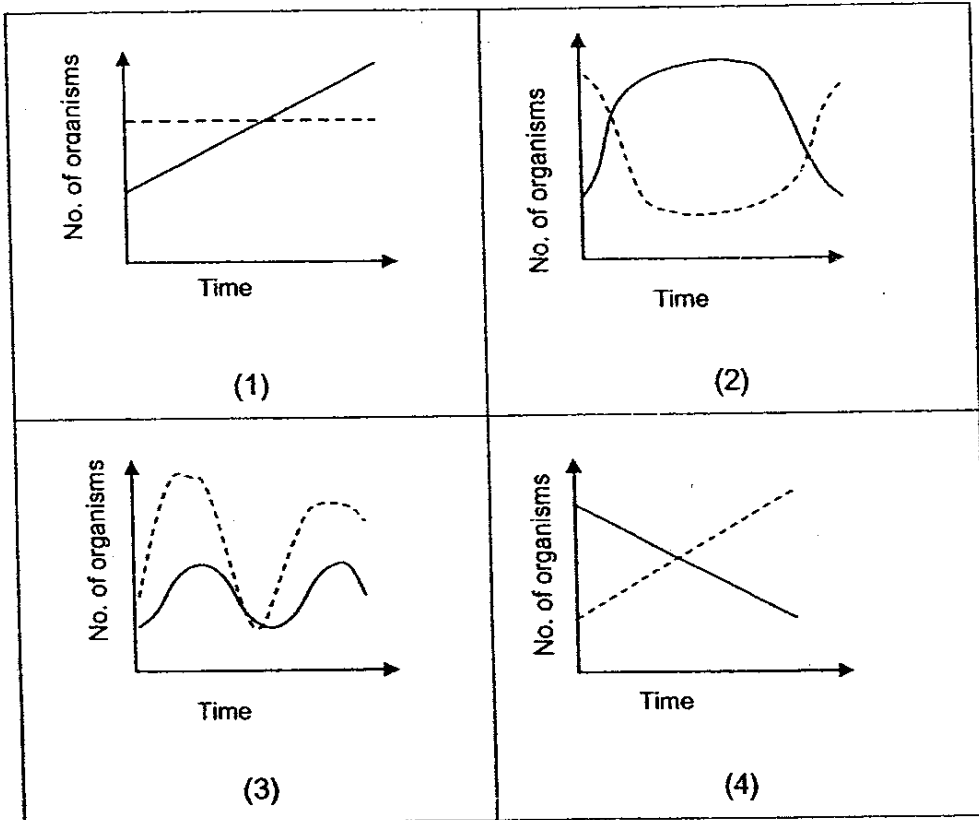

Key : \_\_\_\_\_ bird population

----- caterpillar population

28. Justin tested the switches of four circuits. He recorded one set of the results in a table.

Switch A	Switch B	Number of bulbs lighted up
OFF	OFF	0
ON	OFF	1
OFF	ON	1
ON	ON	2

Which one of these electrical circuits will produce the results recorded in the table above?

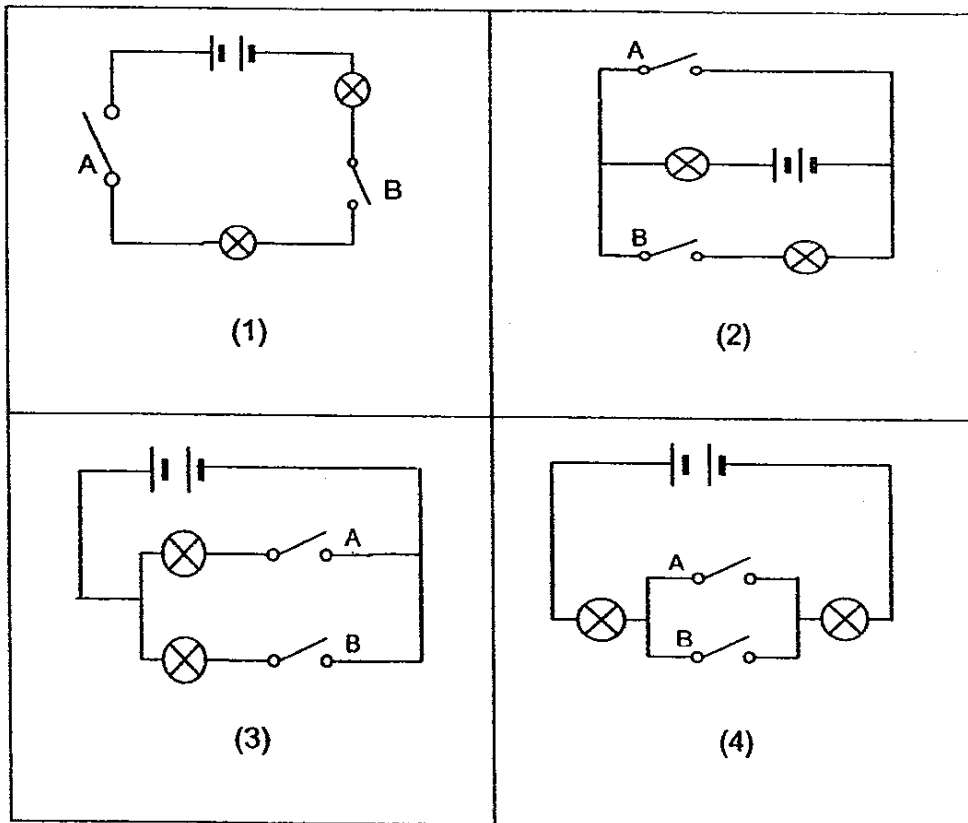

29. The diagram below shows a food web.

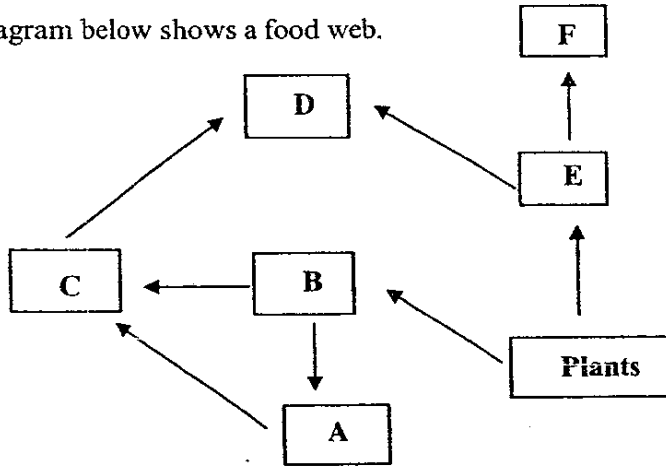

The letters A to F represent food consumers. Which of these food consumers are both predators and preys?

- (1) A and C
- (2) A and F
- (3) B and E
- (4) D and E

30. Minghui found some eggs and set up the following experiment to find out what they need in order to hatch. What was his hypothesis?

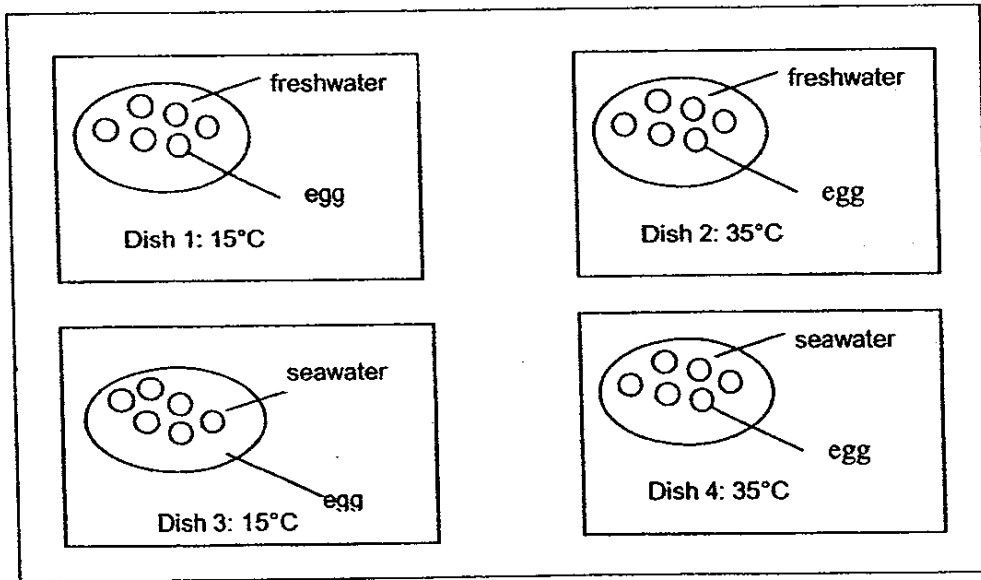

- (1) Eggs need water to hatch.
- (2) Eggs have to be fresh in order to hatch.
- (3) Eggs have to be fertilised in order to hatch.
- (4) Eggs need warmth and fresh water to hatch.

Name: \_\_\_\_\_ ( )

Class: P 6 \_\_\_\_\_

**Section B: 40 marks**

**Read the questions carefully and write your answers in the spaces provided.**

31. Some materials are classified according to one of their properties.

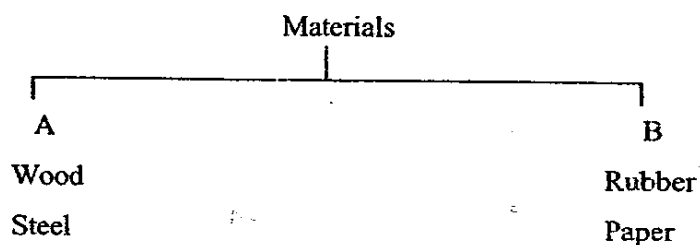

(a) What property is used to classify the two groups of materials?

Group A \_\_\_\_\_ [1]

Group B \_\_\_\_\_ [1]

(b) State a property that is common to all the materials in Group A and B. [1]

\_\_\_\_\_

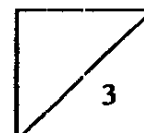

32. A group of pupils were given the following apparatus to make 2 electro-magnets.

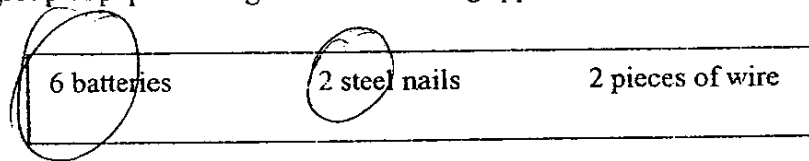

They wanted to investigate if the number of batteries affect the strength of the electro-magnets.

(a) Draw a diagram in each box to show the 2 set-ups needed for the investigation. [2]

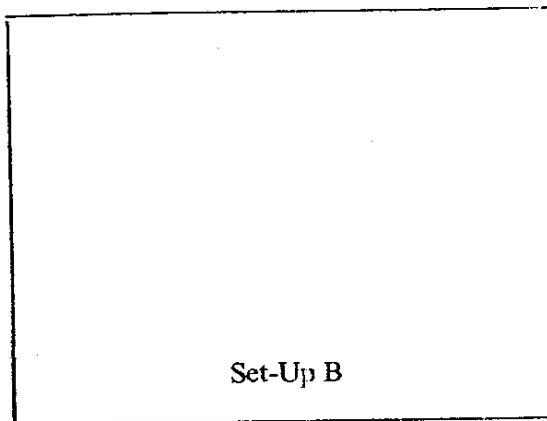
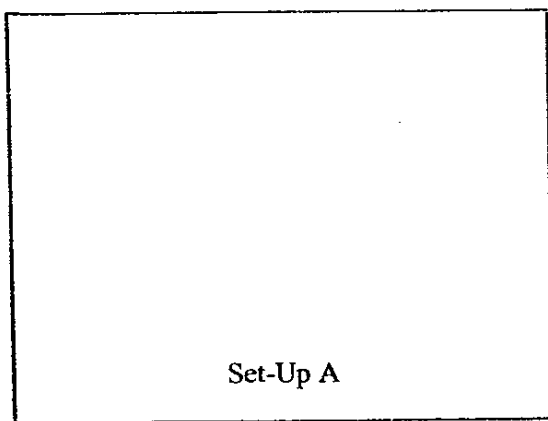

(b) How would he test the strength of the magnets? [1]

---

---

(c) What do you think is the conclusion? [1]

---

---

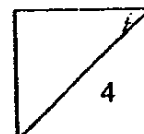

33. The picture below shows <sup>an</sup>angsana tree community in a reservoir. park .



(a) There are \_\_\_\_\_ populations of organisms in the tree. [1]

(b) How are the monkeys dependent on the angona tree? [1]

---

---

(c) How is the angona tree dependent on the animals living in it? [1]

---

---

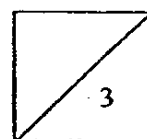

34. Peter collected three soil samples. X, Y and Z. Each sample was put in a funnel which had been plugged with some cotton wool. A beaker was placed under each funnel before he poured 100 ml of water into each soil sample. The amount of water that was collected in each beaker was recorded as shown in the table below.

Soil Sample	Amount of water collected (ml)
X	80
Y	95
Z	45

- (a) What is the aim of the experiment? [1]

---

---

- (b) What type of soil is Sample Y? [1]

---

- (c) Why is Sample Y not suitable for growing most plants? [1]

---

---

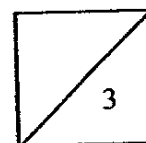

35. A school pond was found to have many mosquito eggs. To prevent the mosquitoes from breeding, the school gardener sprayed a thick layer of oil over the surface of the pond

(a) How would the gardener's action affect the aquatic plants in the school pond? Why? [1]

---



---

(b) How can the gardener get rid of mosquitoes without polluting the pond? [1]

---



---

36. The table below shows how two plants adapt themselves.

(a) Complete the table by writing the correct answers in boxes X and Y. [1]

Plant	Feature/characteristics	The adaptation helps the organism to
Water hyacinth	Spongy leaf filled with air	(X)
Money plant	(Y)	Climb a support

(b) Why does the money plant need to climb a support? [1]

---



---

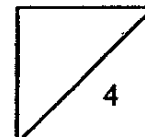



37. An ostrich has wings but it cannot fly.

(a) What are the two possible reasons an ostrich cannot fly?

(i) \_\_\_\_\_  $[\frac{1}{2}]$

(ii) \_\_\_\_\_  $[\frac{1}{2}]$

(b) How can an ostrich escape from its enemies?  $[1]$

\_\_\_\_\_  
\_\_\_\_\_

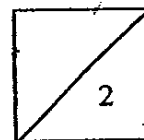

38. The diagram shows 4 fishes.



A

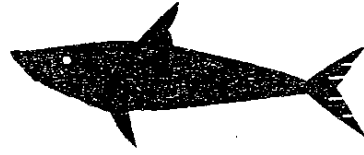

B



C

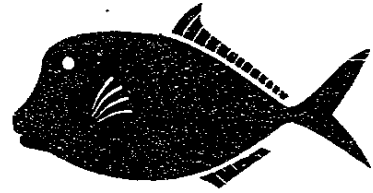

D

(a) Put the fish into two groups by writing A, B C, and D in the boxes. [2]

Group X

Group Y

(b) Why have the fishes been classified this way? [1]

---

---

---

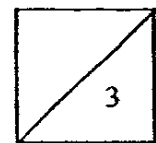

39. Jason is asked to show that sunlight is needed for photosynthesis to occur. Complete the following table to show the steps he would take in carrying out the experiment and the reasons for each step so that he can test whether the plant has photosynthesized. [2]

	Steps	Reasons
1	Take two pots of plants. Keep Pot A in the dark for a few days.	
2	Expose Pot B to sunlight for 5 to 6 hours.	
3		

40. (a) Susan left a piece of bread (Brand X) on the table. It became mouldy after some time. Where did the mould come from? [1]

---



---



---

- (b) Alice also left a piece of bread (Brand Y) on the same table. She did not observe any mould on it after some time. Give a reason to explain her observation. [1]

---



---



---

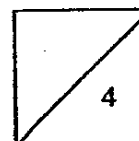

41. An experiment was set up as shown in the diagram below.

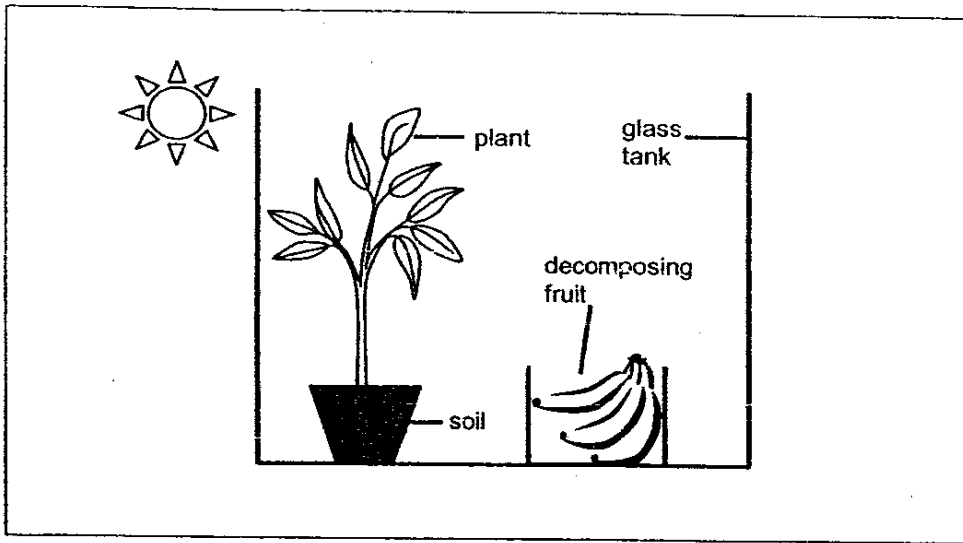

(a) How is the decomposing fruit useful to the plant? [1]

---

---

---

(b) Name 2 conditions which are necessary for decomposition to take place. [1]

(i) \_\_\_\_\_

(ii) \_\_\_\_\_

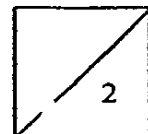

42. Mindy set up a circuit using the same type of batteries and bulbs.

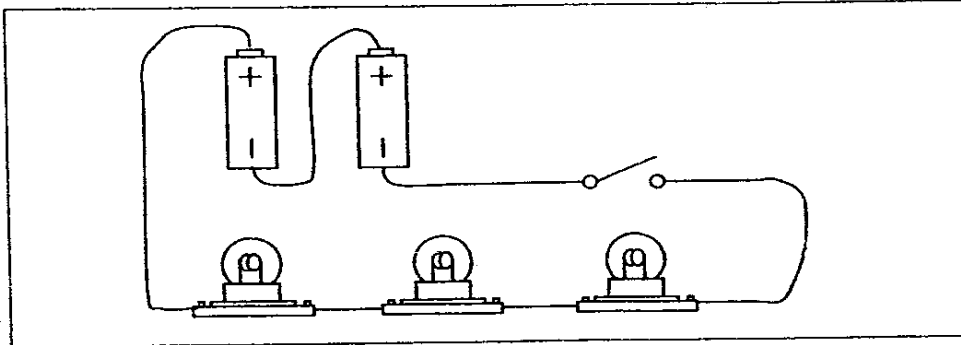

(a) Fill in each blank with a correct word. [1]

When an electric current flows through the \_\_\_\_\_ in a bulb, some of the electrical energy is changed into \_\_\_\_\_ energy, which is useful.

(b) Mindy decided to make some changes to the circuit to produce a brighter light in each bulb. Put a tick beside each statement that describes what she would probably do. [1]

1	Remove one or two bulbs.	
2	Lengthen the wire.	
3	Reconnect the bulbs in a parallel arrangement.	
4	Reconnect the batteries in a parallel arrangement.	
5	Add more batteries.	

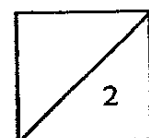

43. The diagrams below show Set-ups A, B and C.  
 In each arrangement, an effort is applied to lift the same load.  
 The statements in the table below describe what happens when the pulleys are used.  
 Complete the table by writing the correct set-ups beside each statement. [3]

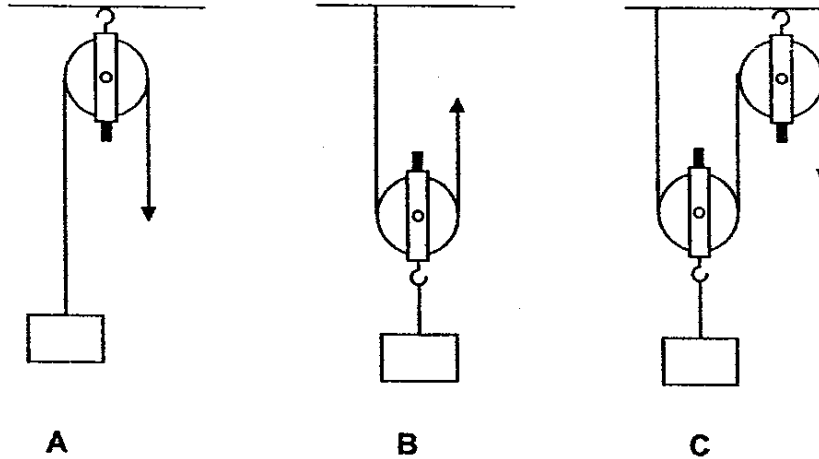

	Statements	Pulley Arrangements
(a)	It changes the direction of the force.	
(b)	The effort needed is smaller than the load.	
(c)	The distance moved by the effort is greater than that of the load.	

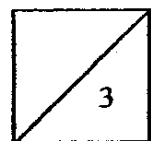

44. Nick set up 5 pots, each containing 10 small cabbage plants. Each plant was 4-5 cm tall, and each pot had the same amount of soil in it. On the day after the cabbages were planted, Nick added different amounts of liquid fertiliser to each pot. From then on, he watered the plants with the same amount each day. He observed the growth of the plants over 10 days. His results are shown below.

Pot	Amount of liquid fertiliser added	Observations after 10 days	
		Leaves	Average Height
1	None	Pale green leaves	8 cm
2	5 ml	Green leaves	12 cm
3	10 ml	Green leaves	15 cm
4	15 ml	Green leaves	16 cm
5	20 ml	Yellow leaves	8 cm

- (a) What was the aim of Nick's investigation? [1]

---

---

---

- (b) What conclusion can you draw from his results? [1]

---

---

---

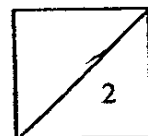

60

45. Solution X changes colour when the amount of carbon dioxide dissolved in it changes. This is shown in the table.

Colour of Solution X	Amount of dissolved carbon dioxide
Reddish orange	Same amount of carbon dioxide as in the air
Yellow	More carbon dioxide than in the air
Purple	Less carbon dioxide than in the air

Three test tubes filled with water were set up. The diagrams below show what was put inside the test tubes.

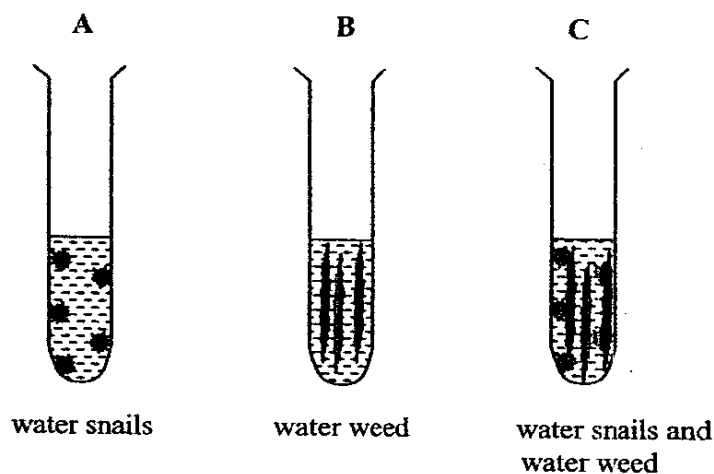

Solution X was then poured into each test tube. The test tubes were left in the sunlight for 2 hours.

- (a) What would be the colour of the Solution X in test tube A? [1/2]

---

- (b) Name the process taking place in the cells of the water snails which causes this colour change. [1/2]

---

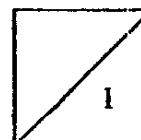



(c) What would be the colour of the Solution X in test tube B? [1/2]

---

(d) Name the process taking place in the cells of the water weed which causes this colour change. [1/2]

---

(e) Assuming that the colour of Solution X in test tube C did not change, explain why. [1]

---

---

---

46. Tammy keeps lots of plants in her room. She read somewhere that plants grow better if you play music near them. She decided to construct a suitable idea that she can test with an experiment. Rearrange the following sentences, using numbers 1 to 7 to show the correct order of steps Tammy should take. Step (1) has been done for you. [2]

Steps	Order
State the hypothesis.	
Make a plan.	
Construct an idea.	
Carry out the plan.	
Check the hypothesis.	
Design the experiment.	
Draw a conclusion	

~ End of Paper ~  
~Please check your work carefully~

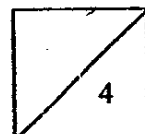

b2  
End

# Ai Tong Primary School

## Primary 6 Science SA1 Exams (2006)

### (ANSWER KEY)

#### SECTION A : (60 MARKS)



Qn no.	Ans
1	3
2	4
3	3
4	4
5	2
6	4
7	1
8	4
9	3
10	1

Qn no.	Ans
11	3
12	3
13	1
14	4
15	2
16	3
17	3
18	1
19	3
20	2

Qn no.	Ans
21	2
22	1
23	2
24	4
25	2
26	2
27	3
28	3
29	1
30	4

#### SECTION B (40 MARKS)

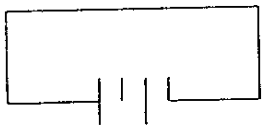
Qn No.	Answers
31a	A : hard                      B : soft
31b	They are opaque.

32a	<div style="display: flex; justify-content: space-around;"> <div style="text-align: center;"> <p>Set-Up A</p>  </div> <div style="text-align: center;"> <p>Set-Up B</p>  </div> </div>
32b	Place some paper clips and test the number of clips that is picked up the electro magnet in the 2 set-ups. The electro magnet that picks up more paper clips is the stronger magnet.
32c	The more batteries he used, the stronger is the electro magnet.

33a	6
33b	They take shelter in it.
33c	The angšana tree needs the waste of the animals to nutrient itself.

Qn No.	Answers
34a	He wanted to find out the amount of water the soil samples could retain.
34b	Sandy
34c	Plants will wilt and die from lack of water as sand does not retain enough water.

35a	The aquatic plants would die. The layer of oil prevents oxygen from reaching the aquatic plants, so the aquatic plants would not get any oxygen and they would die.
35b	He can put some frog into the pond to let the frog eat the mosquito eggs.

36a	X : float on the water                      Y : clasping roots.
36b	It has weak stem so it needs to climb a support to get sunlight.

37a (i)	It is very heavy.
(ii)	It has undeveloped flight muscles.
37b	An ostrich runs very fast so when it sees its enemies, it can quickly run away.

38a	X : A , D                      Y : B , C
38b	Group X do not have streamlined body shape but Group Y has streamlined body shape.

39	1) To destarch the leave.
	2) To allow photosynthesis to take place.
	3) Remove one leaf from each pot and test it with iodine. To test for the presence of starch.

40a	They were mould spores floating in the air.
40b	It was dry.

41a	It gives out carbon dioxide for the plant to photosynthesis so the plant will not die.
41b (i)	Air
41 (ii)	warmth

42a	Filament, light
42b	1, 3, 5

43a	A, C
43b	B , C
43c	B , C

44a	The effect of liquid fertilizer on the growth of plants.
44b	When 15ml of liquid fertilizer was added the average height of the plants is the highest.
45a	Yellow
45b	Respiration
45c	Purple
45d	Photosynthesis
45e	Carbon dioxide was being used up and produced at the same rate as water snails produced carbon dioxide and water weeds used it up.
46	3, 4, 1, 5, 7, 2, 6