

SA2



# RED SWASTIKA SCHOOL

## SCIENCE 2021 PRELIMINARY EXAMINATION PRIMARY 6

Name : \_\_\_\_\_ ( )

Class : Primary 6/ \_\_\_\_\_

Date : 24 August 2021

### BOOKLET A

Total time for Booklets A & B: 1h 45 min

Booklet A: 28 questions (56 marks)

Note:

1. Do not open the booklet until you are told to do so.
2. Read carefully the instructions given at the beginning of each part of the booklet.
3. Do not waste time. If the question is too difficult for you, go on to the next question.
4. Check your answers thoroughly and make sure you attempt every question.
5. In this booklet, you should have the following:
  - a. Page 1 to Page 21
  - b. Questions 1 to 28



**Section A**

For Questions 1 to 28, choose the most suitable answer and shade its number in the OAS provided.

1. The diagrams below show two animals.

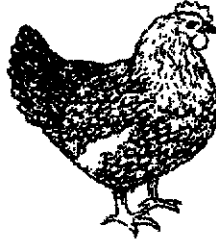

How are the animals similar?

They \_\_\_\_\_

- (1) have feathers
  - (2) reproduce by laying eggs
  - (3) have a three-stage life cycle
  - (4) reproduce by giving birth to young alive
2. Which of the following about the fern and the mushroom is correct?
- (1) They have chlorophyll.
  - (2) They are non-flowering plants.
  - (3) They do not reproduce by seeds.
  - (4) They do not make their own food.

3. Cong Min learnt that grasshoppers get water through the leaves that they eat. He wanted to find out how long a grasshopper can survive without food and water. He prepared two similar glass jars, A and B, as shown below.

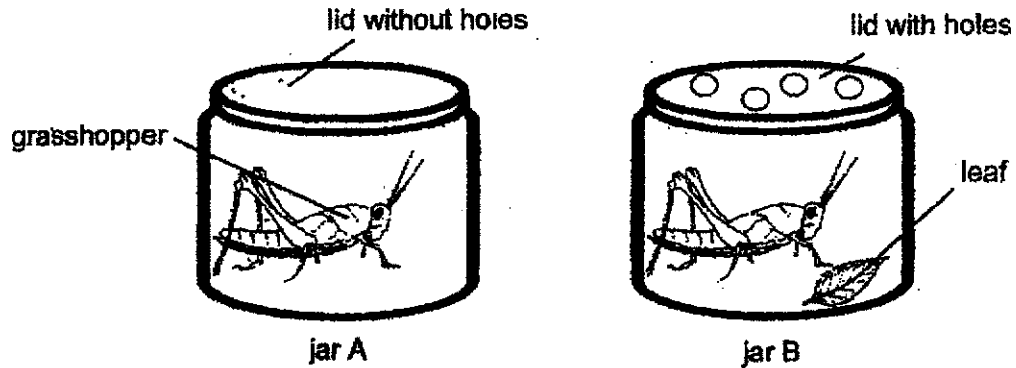

What must Cong Min do to ensure that his investigation is fair?

- (1) Add one leaf into jar A.
  - (2) Remove one leaf from jar B.
  - (3) Use a lid with four holes to close jar A.
  - (4) Use a lid without holes to close jar B.
4. Diagrams 1 and 2 below show the reproductive parts of a flower and a human respectively.

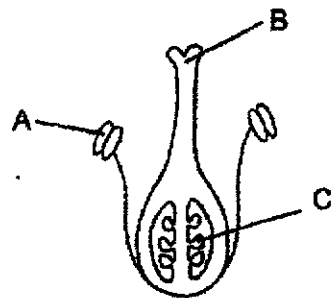

diagram 1

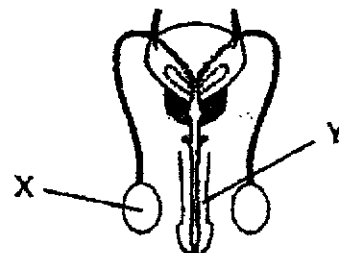
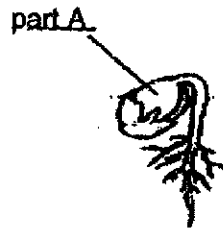

diagram 2

Which of the following pairs have a similar function?

- (1) A and Y
- (2) C and Y
- (3) B and X
- (4) A and X

5. Chun Ling observed the growth of a seedling over a period of time. She measured the mass of part A every day and presented her data in a line graph.



Which one of the following graphs is correct?

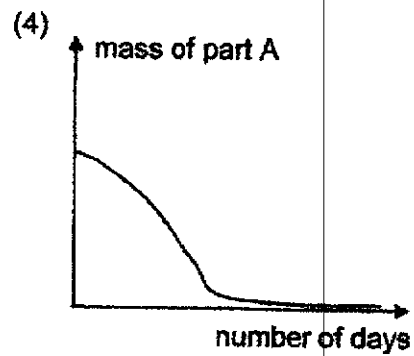
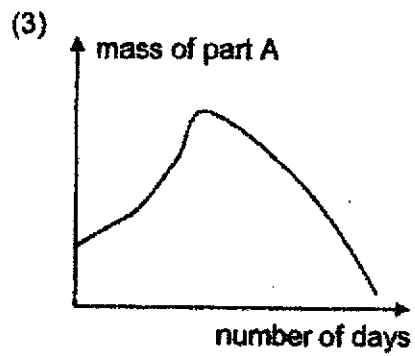
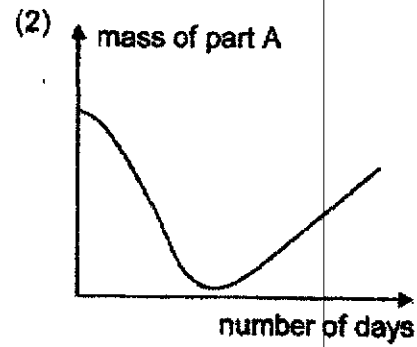
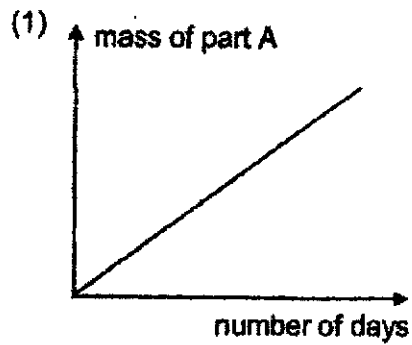

6. Germaine performed an experiment using two similar flowers, X and Y, from the same plant. One of the flowers is shown below.

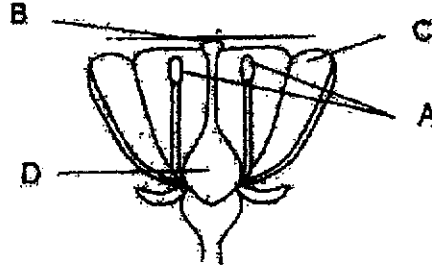

She removed one part from flower X and another part from flower Y. After some time, she recorded which flower could turn into a fruit.

Flower	Presence of a fruit
X	no
Y	yes

Which of the following correctly shows the part of each flower that has been removed?

	Part removed from the flower	
	Flower X	Flower Y
(1)	A	B
(2)	B	D
(3)	D	C
(4)	A	C

7. Study the flow chart.

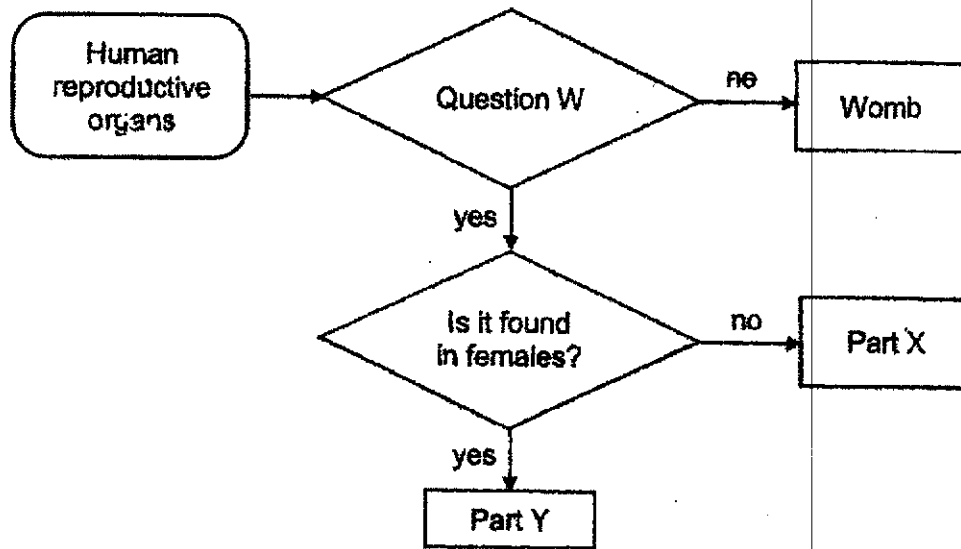

Which one of the following is correct?

	<b>Question W</b>	<b>Part X</b>	<b>Part Y</b>
(1)	Does a fertilised egg develop here?	Penis	Testis
(2)	Does it produce reproductive cells?	Testis	Ovary
(3)	Does it produce reproductive cells?	Ovary	Testis
(4)	Does a fertilised egg develop here?	Penis	Ovary

8. Which one of the following cell parts allows oxygen to enter the cell for its survival?

- (1) Nucleus
- (2) Cell wall
- (3) Cytoplasm
- (4) Cell membrane

9. The diagrams below show the exchange of gases in a human and a plant.

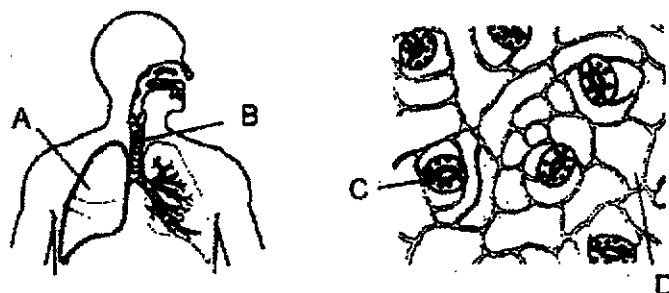

In which parts of these organisms do the exchange of gases take place?

	Human	Plant
(1)	A	D
(2)	B	C
(3)	B	D
(4)	A	C

10. On a cool evening, Xiao Ming wore a face mask when he walked around a park. He did not remove his face mask or talk while walking. When he returned home, he noticed that the underside of the face mask was wet.



Xiao Ming learnt the following points about exhaled air.

- A Exhaled air is warmer than inhaled air.
- B Exhaled air has less oxygen than inhaled air.
- C Exhaled air has more water vapour than inhaled air.

Which of the point(s) can be used to explain why the underside of the face mask was wet?

- (1) C only
- (2) A and B only
- (3) A and C only
- (4) A, B and C



11. Devi wanted to find out if the number of leaves on a plant affect the amount of water absorbed by it.

She prepared one of the set-ups as shown below.

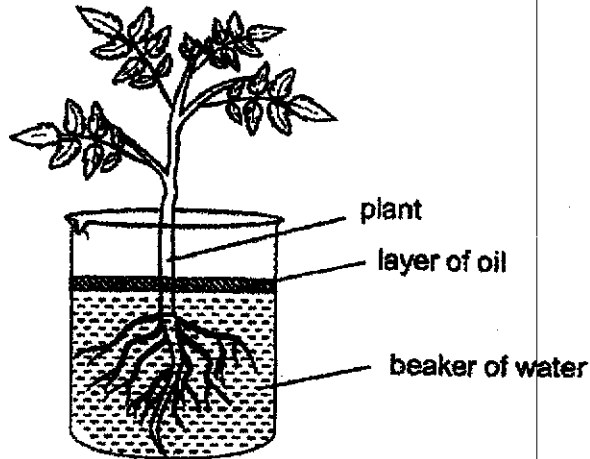

Which of the following variables should Devi keep constant and which variable should she measure at the end of her experiment?

- A type of plant
- B number of roots
- C number of leaves
- D amount of water in the beaker

	Variable(s)	
	to be kept constant	to be measured
(1)	B and C only	D
(2)	A and B only	D
(3)	A and D only	C
(4)	C and D only	B

12. Which of the following about green plants is not correct?

- (1) They are made of cells that have cell walls.
- (2) They take in carbon dioxide when they make food.
- (3) They do not need energy to carry out life processes.
- (4) They do not move freely from place to place on their own.

13. Junxiong carried out an experiment to investigate how the change in light intensity affects the rate of photosynthesis of a water plant.

Which of the following graphs shows the result he is likely to obtain at the end of the experiment?

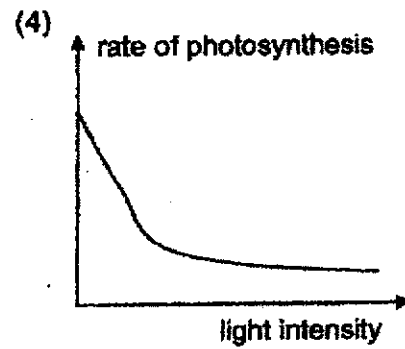
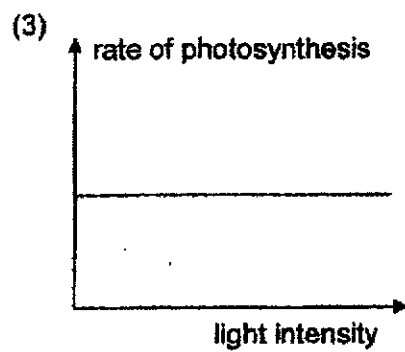
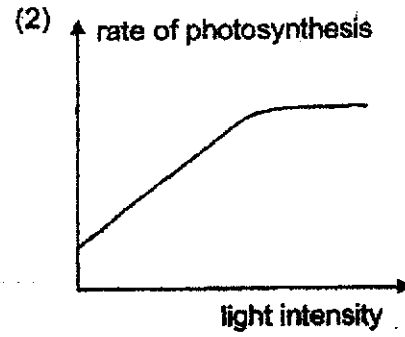
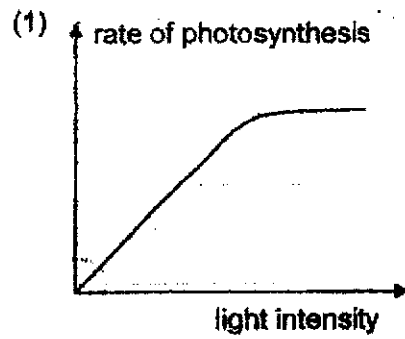

14. Pei Xuan measured the amount of carbon dioxide in containers A and B at various times of the day. Both containers were placed at the garden and it was cloudless the whole day.

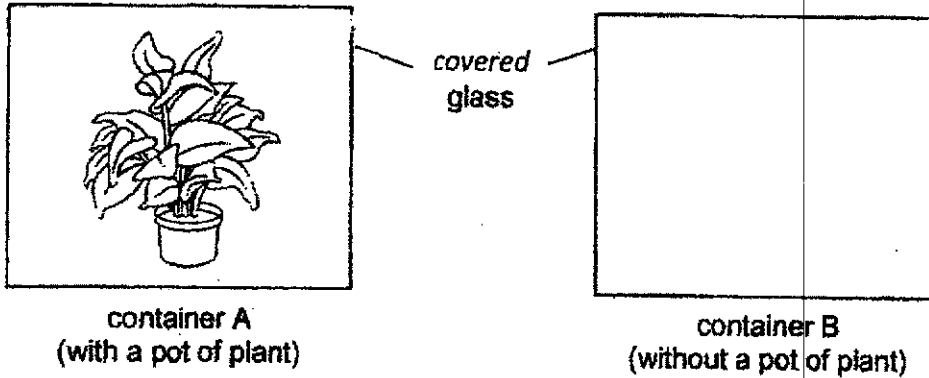

She recorded her findings in the table below.

Time of the day	Amount of carbon dioxide in container A (units)	Amount of carbon dioxide in container B (units)
3 am	X	3
9 am	2.5	3
12 pm	Y	3
3 pm	2.5	3
9 pm	3.5	Z

Which of the following is the most possible?

	X	Y	Z
(1)	4	2	3
(2)	3	2	4
(3)	2	3	4
(4)	4	3	3

15. Zac observed four materials, A, B, C and D. He classified them as shown.

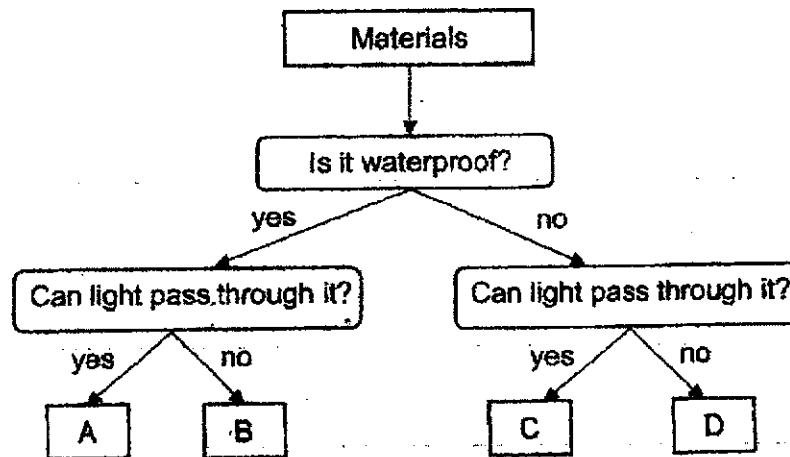

Based on the information above, which material, A, B, C or D, is most suitable to be used for part X of a thermometer?

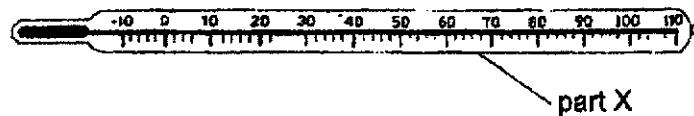

- (1) A
- (2) B
- (3) C
- (4) D

16. A beaker containing 100 ml of liquid L was placed on a table.

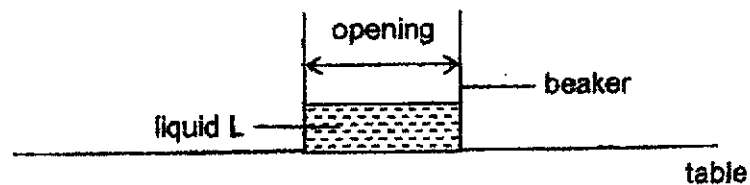

The volume of liquid L remaining in the beaker after a day was measured.

Which of the following could have been done so that more liquid L can remain in the beaker after a day?

- (1) Use a beaker with a wider opening.
- (2) Use a beaker with a narrower opening.
- (3) Place the beaker at a more windy location.
- (4) Place the beaker at a more sunny location.

17. Yasmin sets up an experiment with a pump and a sealed container as shown below. The container has a capacity of  $200 \text{ cm}^3$  and contains  $80 \text{ cm}^3$  of water at the start of the experiment. As she pushes the pump, more air is pumped into the container.

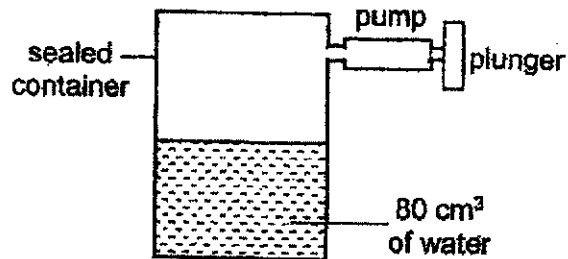

Which of the following graphs shows the volume of air in the container as she pushes the plunger?

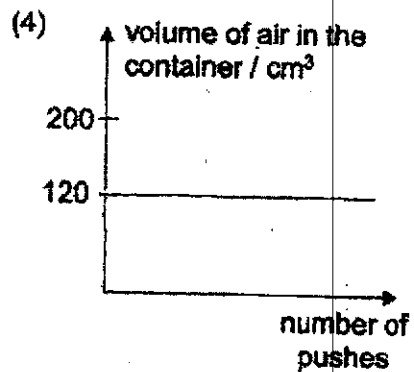
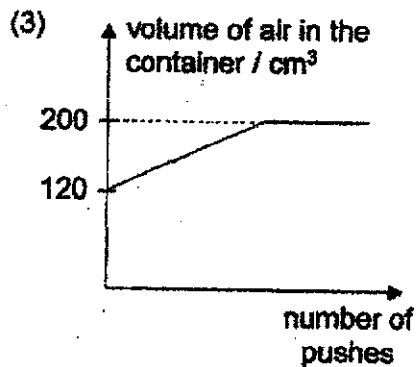
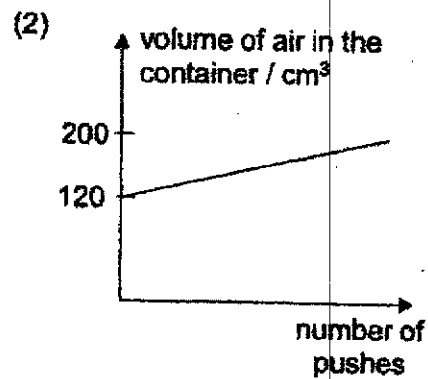
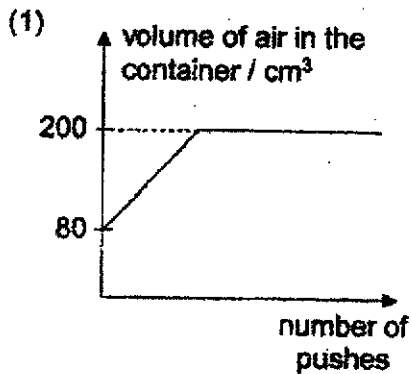

18. The table shows the melting and boiling points of substances P and Q.

Substance	P	Q
Melting point ( $^{\circ}\text{C}$ )	120	180
Boiling point ( $^{\circ}\text{C}$ )	450	400

Which of the following statements are correct?

- A P and Q are in different states of matter at  $420^{\circ}\text{C}$ .  
 B P turns into a gas at a higher temperature than Q.  
 C P turns into a solid at a higher temperature than Q.  
 D Both P and Q are in the same state of matter at  $100^{\circ}\text{C}$ .

- (1) A and B only  
 (2) C and D only  
 (3) A, B and D only  
 (4) A, B, C and D

19. Winnie set up four different circuits using identical bulbs and batteries as shown below.

In which circuit would bulb P be the brightest?

(1)

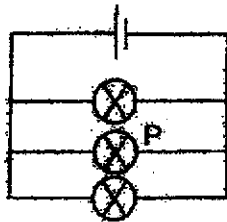

(2)

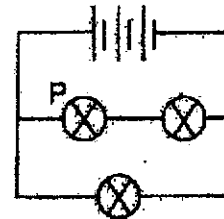

(3)

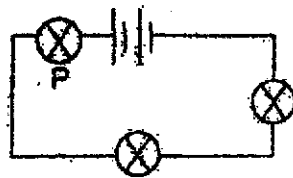

(4)

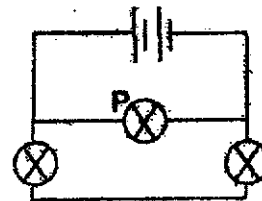

20. Three circuits were set up as shown below. The bulbs, batteries and wires are in working condition. W, X, Y and Z are objects used in the circuits. Bulbs B1 and B2 lit up but bulb B3 did not light up.

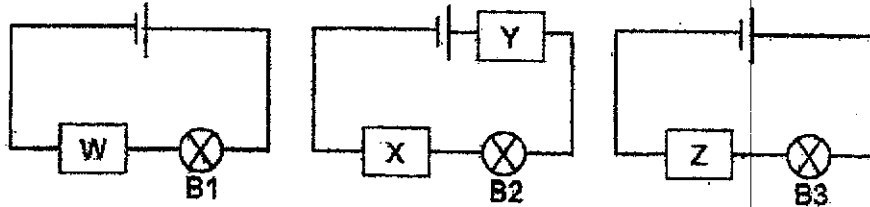

All the objects and bulbs are re-arranged to form another circuit shown below. Bulb B3 did not light up but bulbs B1 and B2 lit up.

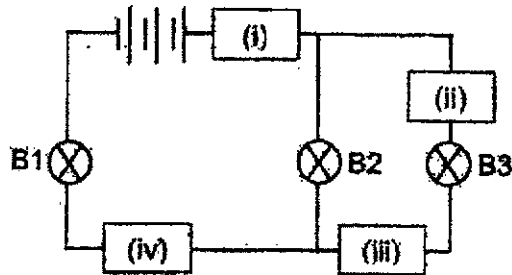

Based on the information above, which of the following correctly shows the positions of W, X, Y and Z?

Position of object				
	(i)	(ii)	(iii)	(iv)
(1)	W	X	Y	Z
(2)	X	W	Z	Y
(3)	Y	W	X	Z
(4)	Z	Y	W	X

21. Four identical bulbs, B1, B2, B3 and B4, were connected in a circuit as shown below. When the switch was closed, all four bulbs lit up.

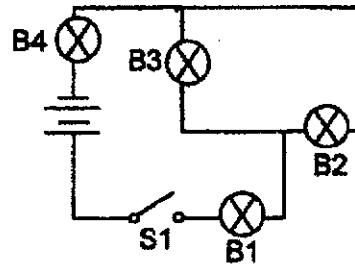

Which of the following is likely to be observed when only one of the bulbs in the circuit is fused at one time?

	Bulb that was fused	Smallest number of bulbs that remains lit	Largest number of bulbs that remains lit
(1)	B1 or B3	1	2
(2)	B2 or B4	0	3
(3)	B3 or B2	2	3
(4)	B4 or B1	0	3



22. The same end of bar A was brought close to two magnets and an iron bar as shown below.

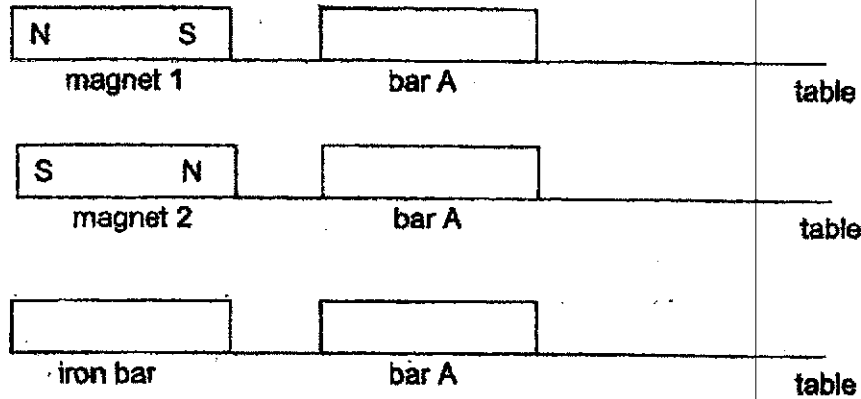

The same procedure was repeated for bar B. The results are shown in the table below.

Bar	magnet 1	magnet 2	iron bar
A	attracted	repelled	attracted
B	attracted	attracted	not attracted

Which of the following are most likely to be bars A and B?

	Bar A	Bar B
(1)	S N	iron bar
(2)	iron bar	S N
(3)	N S	S N
(4)	N S	iron bar

23. The diagram shows how forces are used.

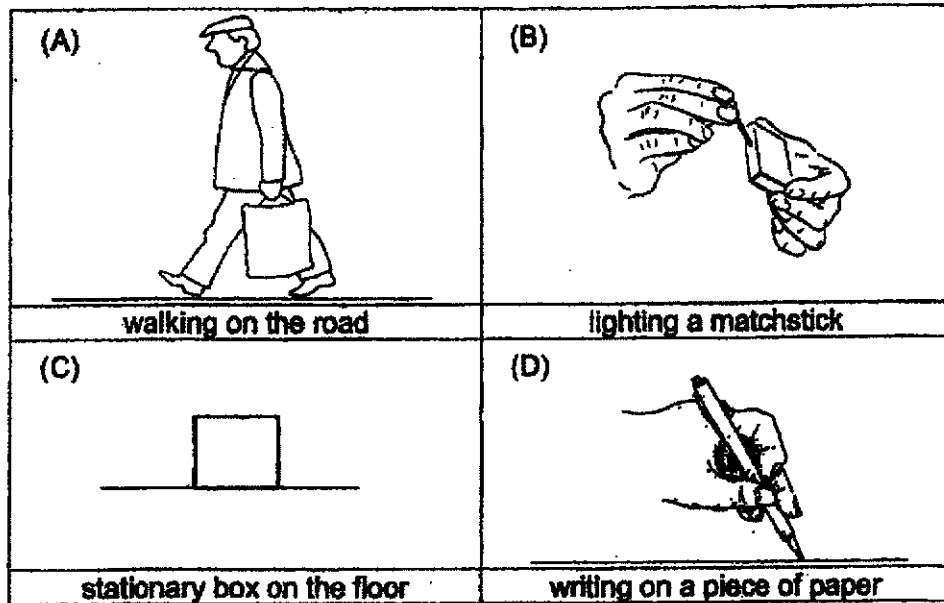

Which of the following diagrams involve friction?

- (1) A and C only
- (2) B and D only
- (3) A, B and D only
- (4) A, B, C and D

24. In the set-up below, the bar magnet is attached to a spring and hung above an electromagnet.

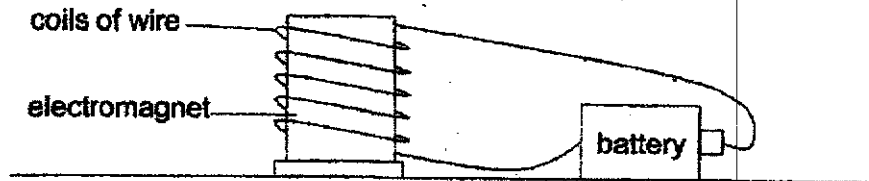
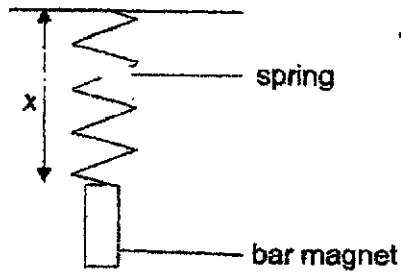

The table below shows the readings of  $x$  as the number of batteries and number of coils of wire around the electromagnet are changed.

Number of batteries used	Number of coils of wire	$x$ (cm)
1	10	5
1	5	A
2	10	9
2	B	11

What are the possible values of A and B?

	A	B
(1)	4	5
(2)	4	20
(3)	10	5
(4)	10	20

25. In an experiment, two identical springs have the same length. When two blocks of different masses, X and Y, were attached to a table top using the springs, the springs were compressed as shown below.

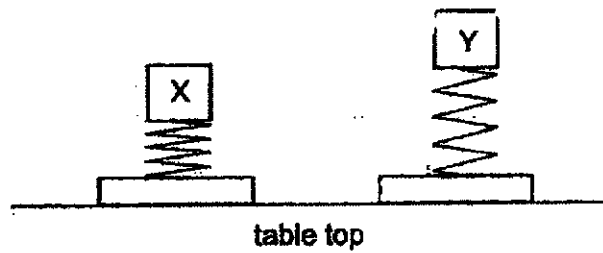

Which of the following is possible?

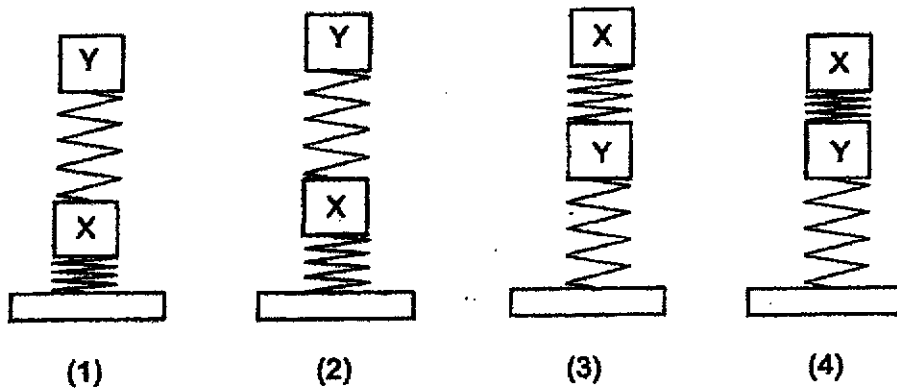

26. The diagram below shows the layout of the stage during a shadow performance.

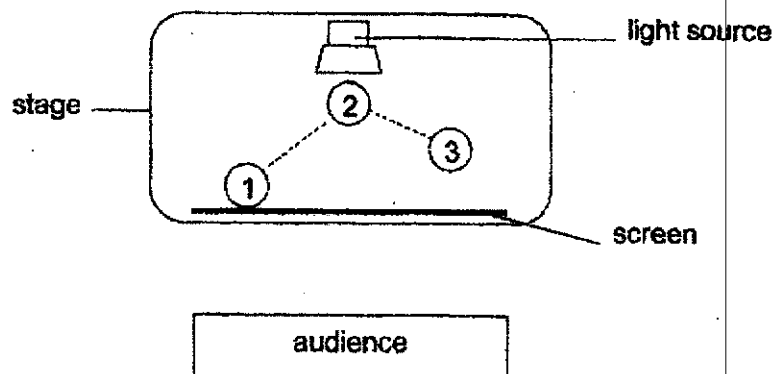

The actor was at position 1 when the show started. He then moved to position 2 and then to position 3. The light cast the shadow of the actor on the screen as shown.

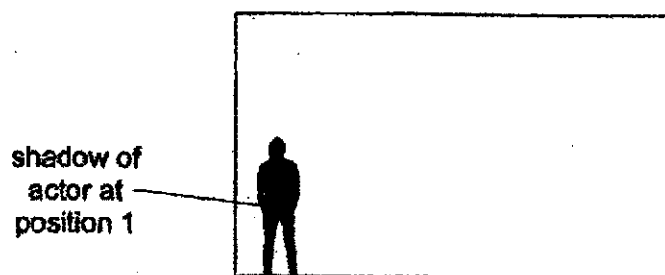

Which of the following statements about the height of his shadow are correct?

- A The height of his shadow is the shortest when he is at position 1.
- B The height of his shadow is the shortest when he is at position 2.
- C The height of his shadow increases when he moves from position 1 to 2.
- D The height of his shadow decreases when he moves from position 2 to 3.

- (1) A and C only
- (2) B and C only
- (3) B and D only
- (4) A, C and D only

27. Four containers made of different materials, A, B, C and D, of the same size were filled with equal amounts of hot water and allowed to cool to room temperature.

The graph shows the changes in temperatures of the water in the four containers

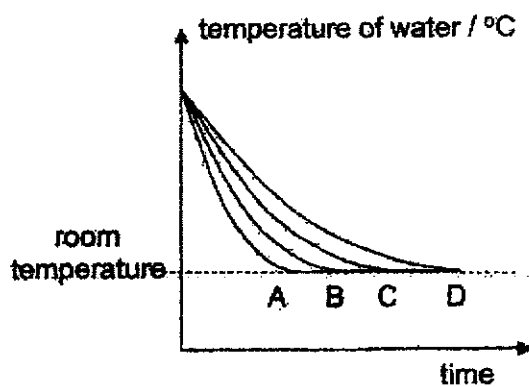

Based on the information above, which material, A, B, C or D, is the most suitable to be used to make the base of a cooking pan?



- (1) A
- (2) B
- (3) C
- (4) D

28. A ball, at rest, is released from position 1 as shown below. It rolled past position 2 and stopped moving when it reached position 3.

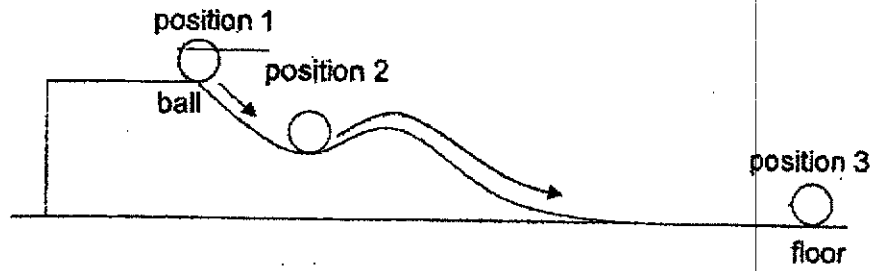

The graph shows the amount of different types of energy of the ball at position-1.

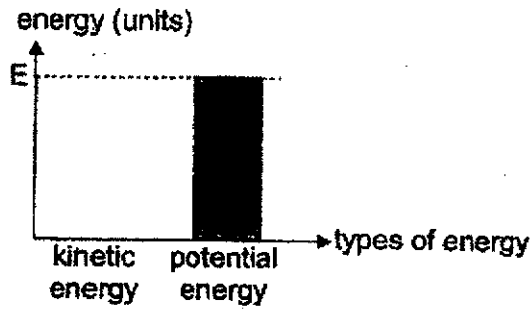

Which of the following graphs shows the amounts of different types of energy at position 2?

(1)

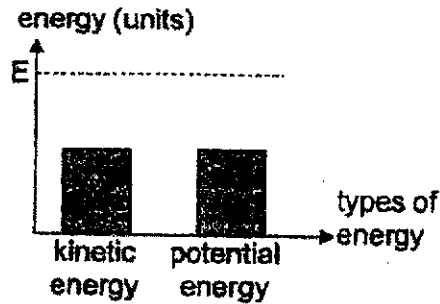

(2)

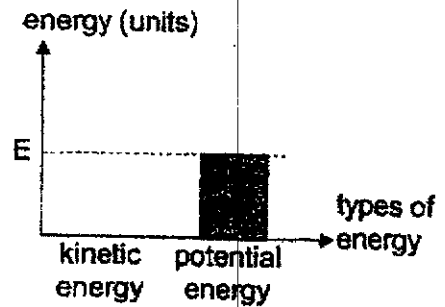

(3)

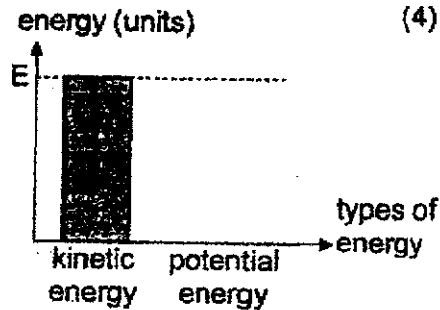

(4)

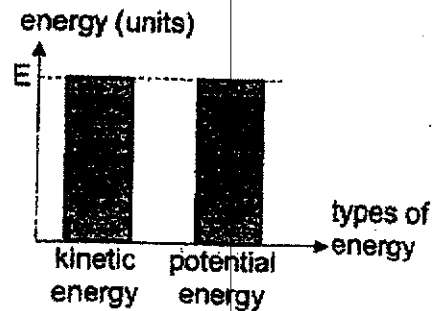

End of Section A







# RED SWASTIKA SCHOOL

## SCIENCE 2021 PRELIMINARY EXAMINATION PRIMARY 6

Name : \_\_\_\_\_ ( )

Class : Primary 6/ \_\_\_\_\_

Date : 24 August 2021

### BOOKLET B

12 Questions  
44 Marks

In this booklet, you should have the following:

- Page 22 to Page 35
- Questions 29 to 40

### MARKS

	OBTAINED	POSSIBLE
BOOKLET A		56
BOOKLET B		44
TOTAL		100

Parent's Signature : \_\_\_\_\_

**SECTION B**

Answer all the questions in the spaces provided.

29. Bacteria B can be found on cooked food and can cause food to spoil when it is present in large numbers. Roger conducted an experiment to find out how quickly bacteria B can reproduce on cooked rice when it is kept at different temperatures. His results are shown below.

Temperature at which bacteria B is kept (°C)	Average amount of bacteria B (unit)	
	At the start of experiment	Six hours later
4	1	1
10	1	32
20	1	256
30	1	4096

- (a) Based on Roger's results, what do bacteria need to reproduce? (1m)
- 
- (b) Based on Roger's results, explain why it is not suitable for cooked food to be kept at 30°C. (2m)
- 
- (c) Suggest why Roger had to use the same amount of cooked rice and the same type of cooked rice for his experiment. (1m)
- 

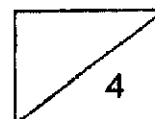

30. A group of scientists visited island X. While they were there, they spotted a neighbouring island, Y. Island X had plants and animals, but there were no plants and animals on island Y.

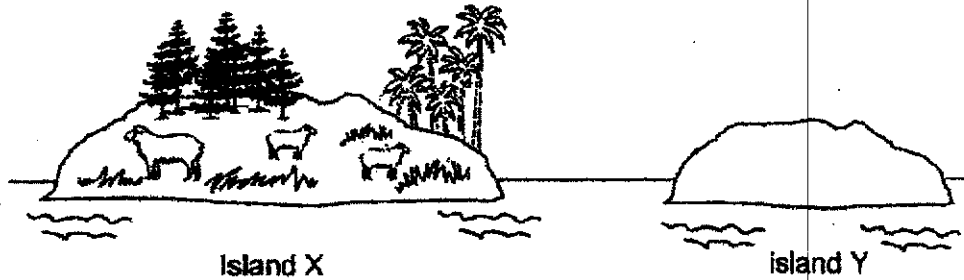

A few years later, the group of scientists went back to the two islands. They observed some plants and animals on island Y.

(a) Suggest one way how plants could have started to grow on island Y. (1m)

---

---

(b) Explain why animal P could be found living on island Y only after plants were found growing there. (1m)

---

---

(c) After some time, one scientist observed that the number of animals on island X remained the same but the number of animal P on island Y increased rapidly.

Explain how the number of animal P on island Y increased. (1m)

---

---

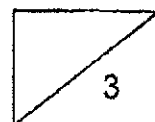

31. Lester used the set-up shown below to investigate if seeds give out carbon dioxide when they germinate.

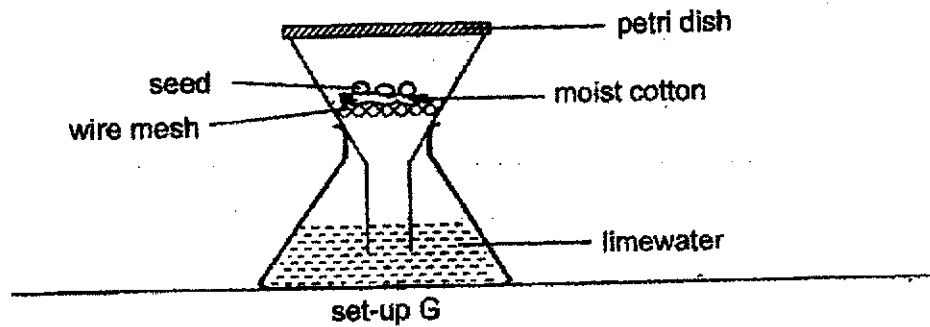

- (a) What are the conditions needed for seeds to germinate? (1m)

\_\_\_\_\_

- (b) What result should Lester observe for his investigation and what conclusion can he make from that observation? (2m)

Observation : \_\_\_\_\_

\_\_\_\_\_

Conclusion : \_\_\_\_\_

\_\_\_\_\_

- (c) Lester's brother advised him to have a control set-up next to set-up G. Tick the items that should be included in the control set-up. (1m)

Item	Tick (✓) to include item into the control set-up
petri dish	
seeds	
moist cotton	
wire mesh	
limewater	

- (d) What is the purpose of the control set-up? (1m)

\_\_\_\_\_

\_\_\_\_\_

32. Diagrams 1 and 2 show the circulatory system of a fish and a human respectively. The arrows, C, D, E, P, Q, R and S, represent how blood flows in the fish and the human.

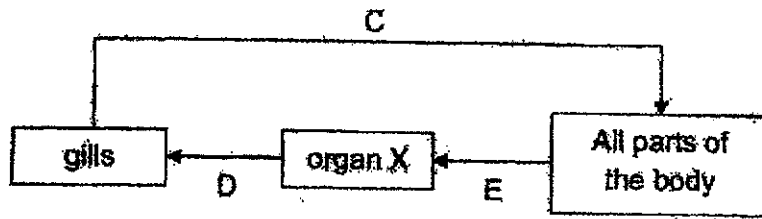

Diagram 1 (fish)

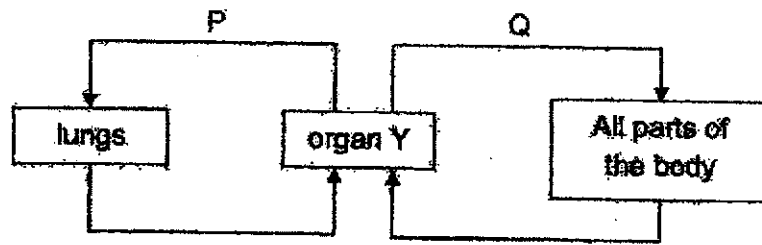

Diagram 2 (human)

(a) Complete the table with information from diagrams 1 and 2. (2m)

Diagram	Arrow(s) representing the movement of blood with the most amount of oxygen	Arrow(s) representing the movement of blood with the most amount of carbon dioxide
1		
2		

(b) Explain how the function of organs X and Y is similar. (1m)

---



---

(c) What is one difference between the movements of blood in a fish as compared to that of a human? (1m)

---



---

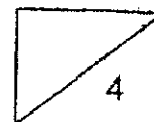

33. Siva conducted an experiment using similar plants in the two set-ups below. He placed them in different corners of a dark room.

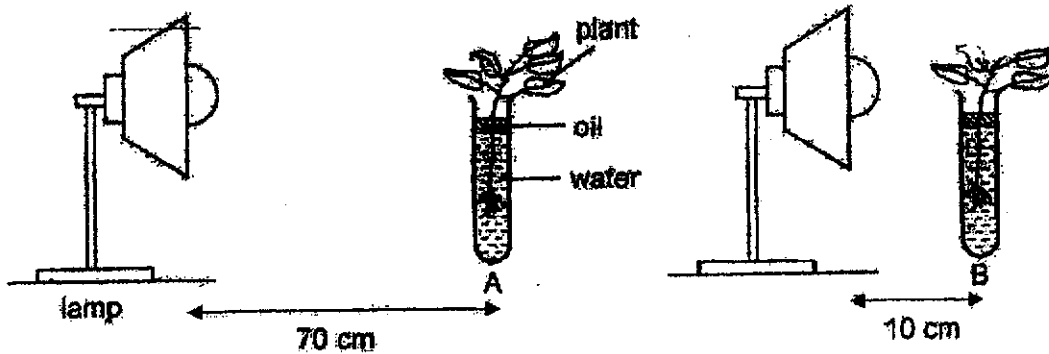

The graph shows the amount of water in test tubes A and B over a period of time.

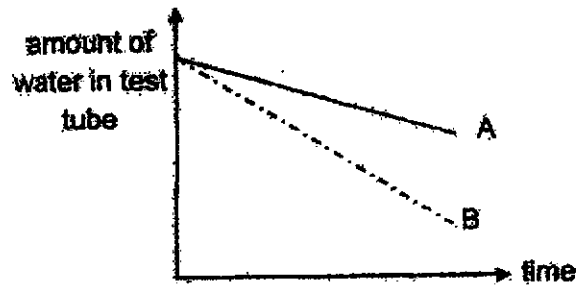

- (a) Based on the graph, what is the relationship between the amount of light and the amount of water in the test tube over time? (1m)

---



---

- (b) Siva observed that the same type of plant growing in a shady area has larger leaves than that growing in a sunny area.



leaf of plant in shady area



leaf of plant in sunny area

Based on Siva's experiment, explain why the leaves of plant growing in a shady area is larger in size. (1m)

---



---

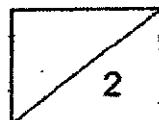

34. Alex wanted to investigate the conditions required for photosynthesis. He selected two similar well-watered potted plants and left them in a dark cupboard for 48 hours. Then, he took the potted plants from the cupboard and placed them in the set-ups shown below.

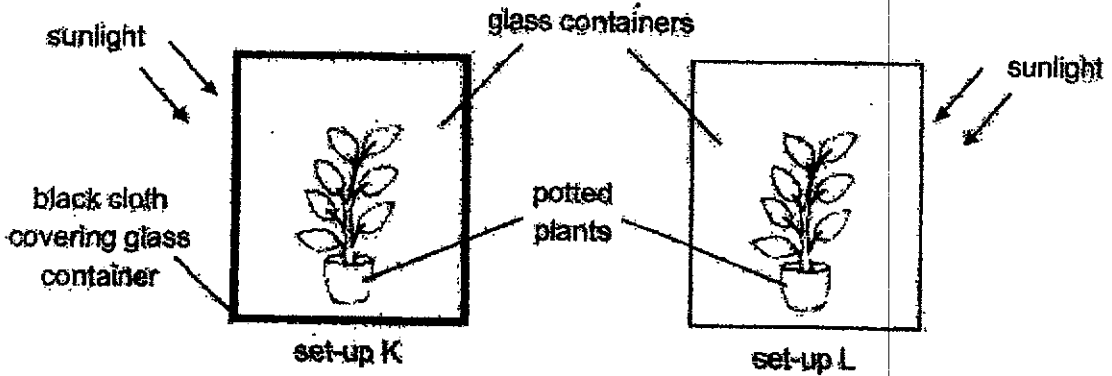

Alex learnt the following points from his Science teacher:

1. Excess sugar produced by leaves is stored as starch.
2. Starch causes iodine solution to change from yellowish brown to dark blue.

After 12 hours, Alex prepared one leaf from each set-up and tested each leaf using iodine solution. He recorded the results of his investigation in the table below.

Set-up	Colour of iodine solution on the leaf
K	yellowish brown
L	dark blue

(a) Describe the process of photosynthesis. (2m)

---



---

(b) Based on the results in the table, what conclusion about photosynthesis can Alex make? (1m)

---



---

(c) Why did Alex leave his potted plant in the dark cupboard for 48 hours before starting his experiment? (1m)

---



---

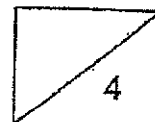

35. Emily switched on the air-conditioner in her bedroom on a warm night. After some time, she noticed that water droplets began to form on the surface of her glass window.

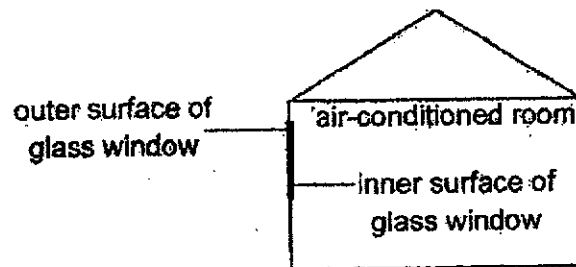

- (a) On which surface of the glass window did the water droplets appear? (1m)
- 
- (b) Explain how the water droplets were formed. (2m)
- 
- 
- 
- (c) Will the water droplets form faster or slower if the glass windows were replaced with a metal sheet? Explain your answer. (1m)
- 
- 
- (d) When she turned off the air-conditioner, the water droplets on the glass window soon disappeared. Explain why. (1m)
- 
- 

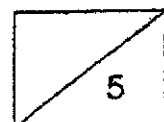



36. Diagram 1 shows the side view of Ravi's toy car. He sets up an electric circuit in the toy car using bulb Q, a switch and some batteries as shown in Diagram 2. All the circuit components are working.

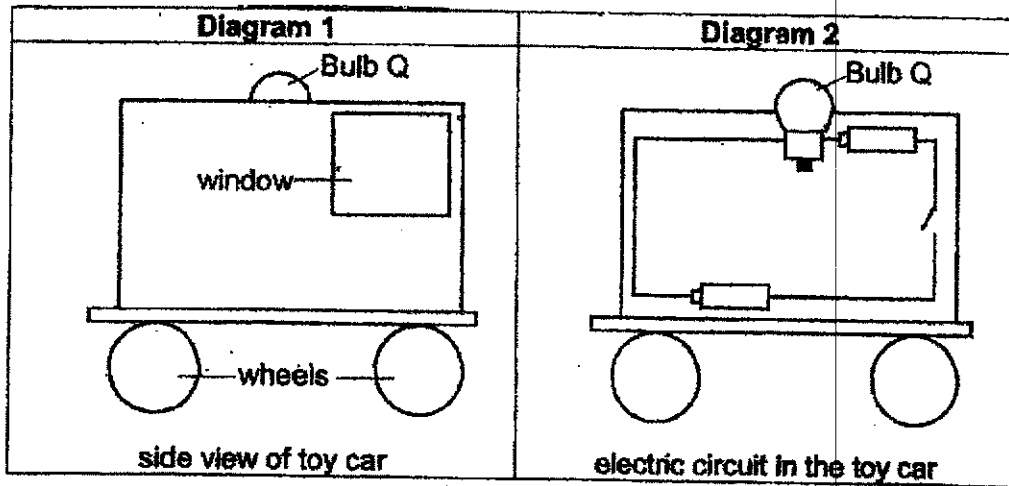

When he closes the switch, the bulb does not light up.

- (a) Draw a circuit inside the toy car below to correct the mistake(s) such that the bulb can light up. (2m)

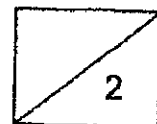
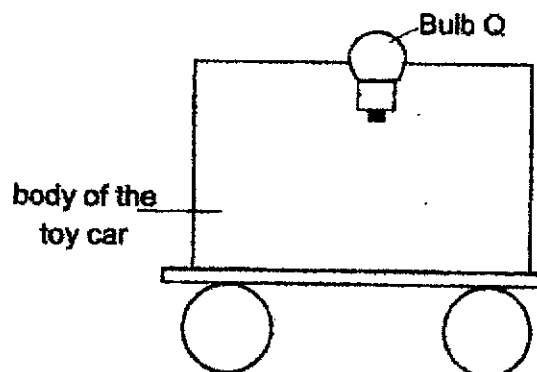

36. Ravi wants to change the design of his car. He re-positions bulb Q and adds three more bulbs, R, T, U, and another switch S2. The front view of his car is shown below.

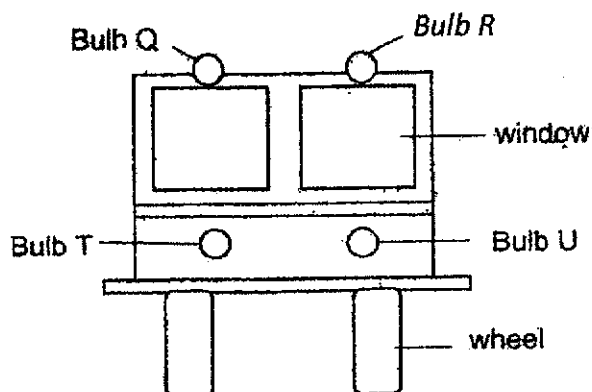

- (b) The bulbs in the toy car will light up as shown in the table below. When all four bulbs are lit, they are equally bright.

	Bulb Q	Bulb R	Bulb T	Bulb U
S1: closed S2: open	yes	yes	no	no
S1: closed S2: closed	yes	yes	yes	yes
S1: open S2: closed	no	no	no	no

The diagram below shows the new circuit in the toy car. In the new circuit,

- (i) mark, with crosses (X), the positions of S1 and S2, (1m) and
- (ii) label the switches correctly with S1 and S2, such that the toy car will work as described in the table. (1m)

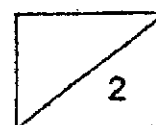
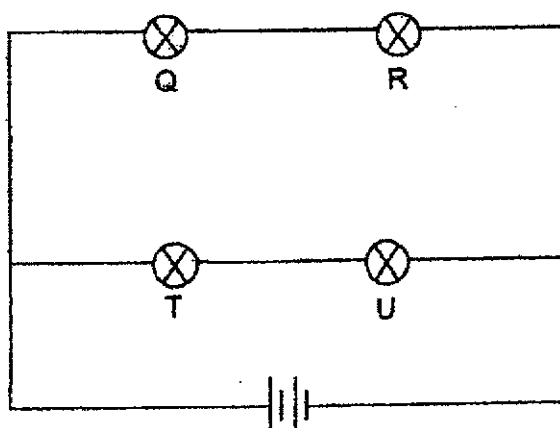

37. Blocks G and H are made of the same material but block G has a bigger mass than block H. After block G was released from the plank, it hit block H at the bottom of the slope. Block H moved a distance of  $d$  cm before it came to a stop.

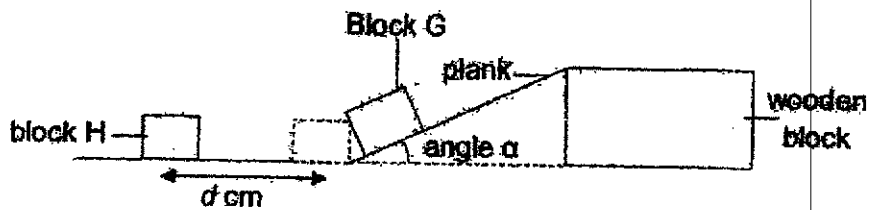
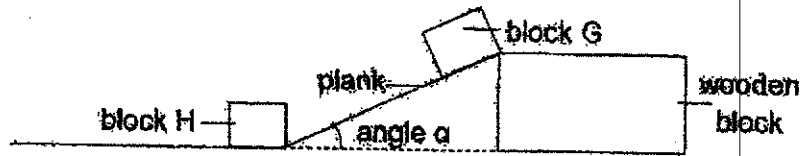

- (a) Name the two forces acting on block G when it was sliding down the plank. (1m)
- 
- (b) Without adding or removing any apparatus, suggest one way to increase distance  $d$ . (1m)
- 

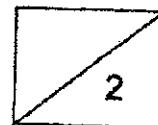

38. Ahmad built a model of a bread toaster as shown below.  
When the switch is closed, the metal tray moves downwards and the Material X gets heated up.

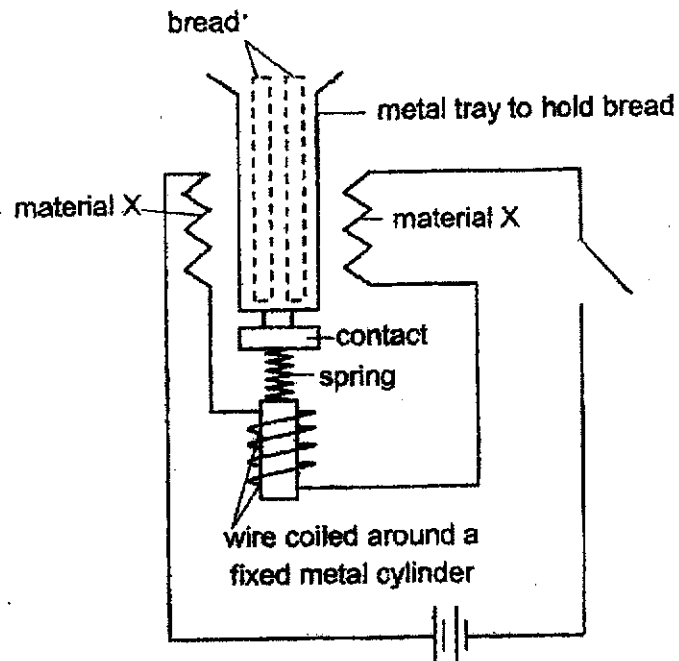

- (a) State a possible material that could be used to make the contact. (1m)
- \_\_\_\_\_
- (b) State a property of the material needed to make Material X. (1m)
- \_\_\_\_\_
- (c) Explain why the metal tray moves downwards when the switch is closed. (2m)
- \_\_\_\_\_
- \_\_\_\_\_
- \_\_\_\_\_

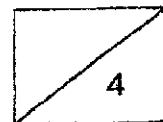

39. Felicia set up an experiment as shown below. A container with a ball is placed at different positions on the retort stand. When the ball is released from the container, it falls onto a plank and rolls downwards before hitting a wooden block, causing it to topple

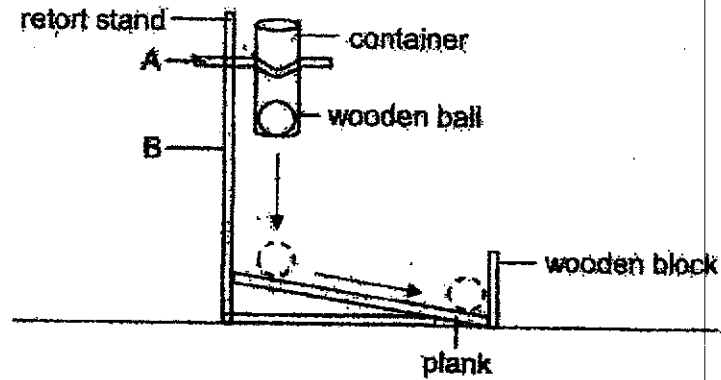

- (a) Fill in the blanks below to show the energy conversion. (1m)

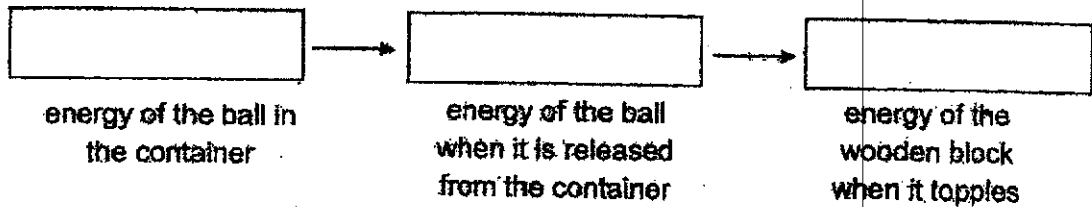

- (b) The container is lowered from position A to B. Will the sound produced by the wooden block be louder or softer when it topples and hits the ground? Explain in terms of energy conversion. (2m)

---



---



---

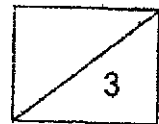

40. Patricia carried out an experiment with the two set-ups as shown below. She used identical containers and burners in both set-ups.

A piece of wax of the same size was placed 5 cm and 20 cm above the base of the container in set-ups X and Y respectively.

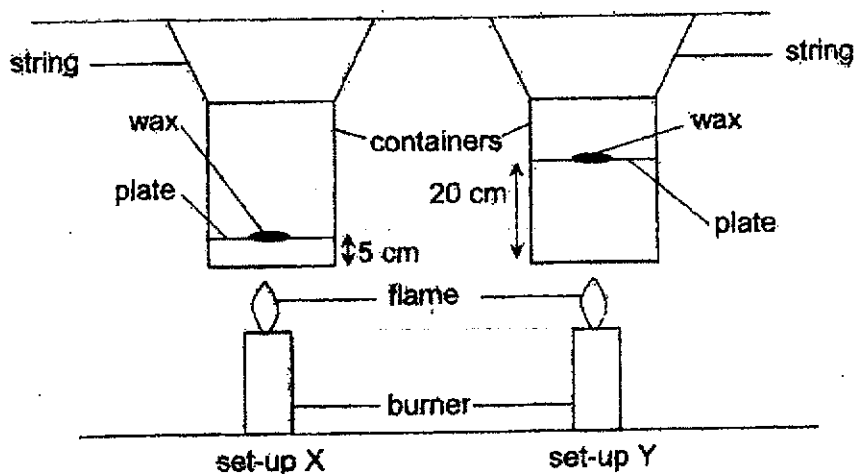

She recorded the time taken for the wax to melt in the table below.

	set-up X	set-up Y
Thickness of the layer of air between the wax and base of container (cm)	5	20
Time taken for the wax to melt (s)	25	96

- (a) What is the relationship between the thickness of the layer of air and the time taken for the wax to melt? (1m)

---



---

- (b) What is the property of air that explains (a)? (1m)

---

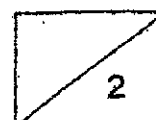

40. Patricia attempted to prepare fried ice cream which is a dessert made from ice cream being coated with a layer of crispy shell made of flour. The coating of the flour helps to prevent the ice cream from melting quickly during the frying process.

She coated two similar ice cream bars with different amounts of flour and fried both ice cream bars using the same amount of heat for 15 seconds. Air bubbles are produced in the flour coating during the frying as shown below.

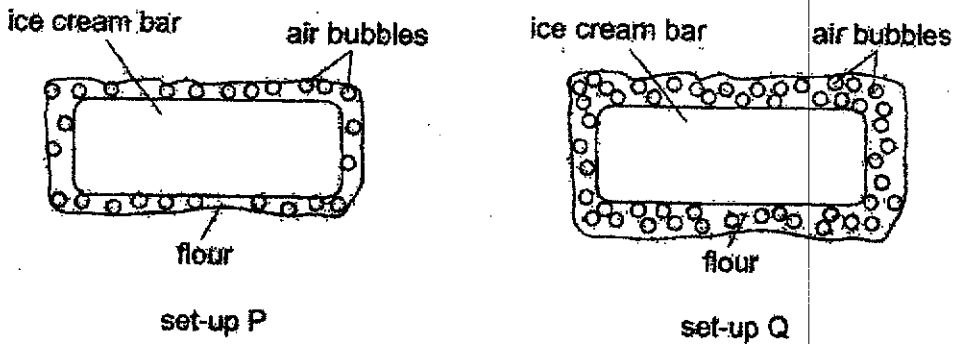

- (c) Should she use set-up P or Q to prevent the ice cream from melting quickly? Why? (2m)

---



---



---

**End of Section B**  
Please check your work.

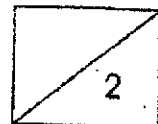





**SCHOOL :** RED SWASTIKA PRIMARY SCHOOL  
**LEVEL :** PRIMARY 6  
**SUBJECT :** SCIENCE  
**TERM :** 2021 PRELIM

**CONTACT :** CALL

**SECTION A**

<b>Q 1</b>	<b>Q2</b>	<b>Q3</b>	<b>Q4</b>	<b>Q5</b>	<b>Q6</b>	<b>Q7</b>	<b>Q8</b>	<b>Q9</b>	<b>Q10</b>
1	3	3	4	4	3	2	4	4	3
<b>Q 11</b>	<b>Q12</b>	<b>Q13</b>	<b>Q14</b>	<b>Q15</b>	<b>Q16</b>	<b>Q17</b>	<b>Q18</b>	<b>Q19</b>	<b>Q20</b>
2	4	1	1	1	2	4	3	4	2
<b>Q 21</b>	<b>Q22</b>	<b>Q23</b>	<b>Q24</b>	<b>Q25</b>	<b>Q26</b>	<b>Q27</b>	<b>Q28</b>		
2	4	3	2	1	4	1	1		

**SECTION B**

<b>Q29)</b>	<p>a) Warmth</p> <p>b) When the rice is kept at 30°C, bacteria B reproduce the quickest and would have the most number of bacteria B, which would not be suitable for people to eat.</p> <p>c) To ensure that the experiment is fair and that only one variable, the temperature at which the bacteria is kept is changed.</p>
<b>Q30)</b>	<p>a) The plant was dispersed by wind and the seed was blown to island Y, and the seed would start to grow on island Y.</p> <p>b) Animal P cannot make its own food so it needs to depend on plants for food.</p> <p>c) Animal P on island Y reproduce and the number of animal P on island increased.</p>

Q31)	<p>a) Warmth, Oxygen and water.</p> <p>b) Observation : The limewater turned cloudy.</p> <p>Conclusion : The seeds take in oxygen and produce carbon dioxide during germination.</p> <p>c) Petri dish, moist cotton, wire mesh, limewater.</p> <p>d) To compare and confirm ensure that the limewater turned cloudy was caused by the seeds giving out carbon dioxide during germination and not by any other variables in the experiment.</p>
Q32)	<p>a) 1) C / D 2) S / P</p> <p>b) They pump blood around the body of the fish and human.</p> <p>c) The blood in a fish transports blood to all parts of the body before reaching organ X while blood in a human transports blood to organ Y before transporting the blood to all parts of the body.</p>
Q33)	<p>a) The greater the amount of light, the less the amount of water in the test tube.</p> <p>b) There is less sunlight and the leaves have to be gigger to take in more sunlight for photosynthesis.</p>
Q34)	<p>a) Photosynthesis is when the leaves trap sunlight with its chlorophyll to convert carbon dioxide and water to produce oxygen and food.</p> <p>b) Photosynthesis requires light.</p> <p>c) The plant will not photosynthesis and the starch in the leaves will be used up by the plants during the 48 hours.</p>
Q35)	<p>a) Outer surface of the glass window.</p> <p>b) The warmer water vapour come into contact with the cooler inner surface of the glass window, lost heat and condensed to form water droplets.</p> <p>c) The water droplets would be formed faster. Metal is a better conductor of heat.</p>

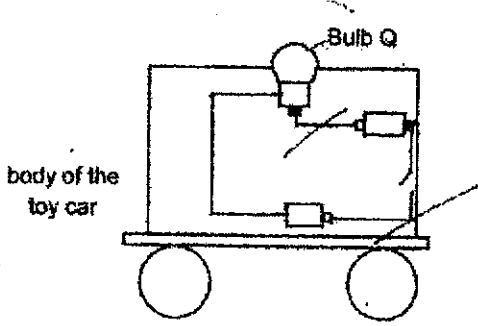
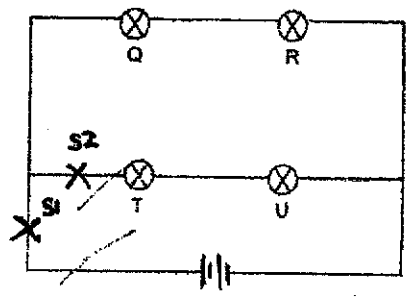
	<p>d) The cooler water droplets gained heat from the warmer surroundings and evaporated to form water vapour.</p>
Q36)	<p>a)</p>  <p>body of the toy car</p> <p>Bulb Q</p> <p>b)</p> 
Q37)	<p>a) Gravitational and frictional forces.</p> <p>b) Make angle <math>a</math> steeper by increasing angle <math>a</math>.</p>
Q38)	<p>a) Iron / Steel / Nickel / Cobalt.</p> <p>b) Good conductor of electricity.</p> <p>c) When the switch is closed a closed circuit is formed and electricity can flow, the fixed metal cylinder would be magnetised and become an electromagnet. The contact would be attracted to the electromagnet, making the spring compressed, thus resulting in the metal tray moving downwards.</p>

Q39)	<p>a) Potential → Kinetic → Kinetic</p> <p>b) The sound produced by the wooden block would be softer. There would be lesser potential energy of the ball in the container converted to lesser kinetic energy of the ball when it is released from the container, causing to hit the wooden block and less kinetic energy is transferred to the wooden block and converted lesser sound energy of the wooden block when it topples.</p>
Q40)	<p>a) As the thickness of the layer of air increases, the time taken for the wax to melt increases.</p> <p>b) Air is a poor conductor of heat</p> <p>c) Set-up Q Having a thick layer of flour creates more air bubbles. Since air is a poor conductor of heat, having more air bubbles reduces the rate of heat gained by the ice-cream from the surroundings and melting quickly.</p>

END