



南洋小學
NANYANG PRIMARY SCHOOL

PRIMARY FIVE SCIENCE
SEMESTRAL ASSESSMENT 2

2007

BOOKLET A

Date : 26 October 2007

Duration : 1 h 45 min

Name : _____ ()

Class: Primary 5 ()

Marks Scored:

Booklet A:		60
Booklet B :		40
Total :		100

Parent's signature:

DO NOT OPEN THIS BOOKLET UNTIL YOU ARE TOLD TO DO SO.
FOLLOW ALL INSTRUCTIONS CAREFULLY.

Booklet A consists of 20 printed pages including this cover page.

Section A (30 x 2 marks = 60 marks)

For each question from 1 to 30, four options are given. One of them is the correct answer. Make your choice (1, 2, 3 or 4). **Shade the correct oval (1, 2, 3 or 4) on the Optical Answer Sheet provided.**

1. The diagrams below show 2 phases of the Moon, M and N, which were observed from the same location on Earth.

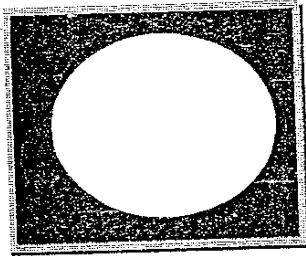

Phase M

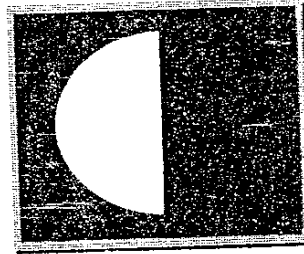

Phase N

Which of the following statement(s) is/are true about the 2 phases?

- A Phase M would always be observed on the same day of each calendar month.
- B Light from the Sun was reflected by the Moon to the Earth during both phases.
- C The positions of the Earth, Sun and Moon during Phase M were different from that in Phase N.

- (1) B only
- (2) A and B only
- (3) B and C only
- (4) A, B and C

2. Which one of the following cell structures is **not** matched correctly to its function?

	Cell Structure	Function
(1)	Nucleus	Controls all activities that take place within a cell
(2)	Cytoplasm	Jelly-like substance where most activities take place
(3)	Chloroplast	Performs the function of photosynthesis within plant cells
(4)	Cell Membrane	Gives the cell a fixed shape and supports the cell

93

3. Asexual reproduction occurs when only one parent is required for reproduction. Which one of the following does not undergo asexual reproduction?

- | | |
|------------|----------------|
| (1) yeast | (2) sperm |
| (3) amoeba | (4) paramecium |

4. The diagrams below show the male and female reproductive systems.

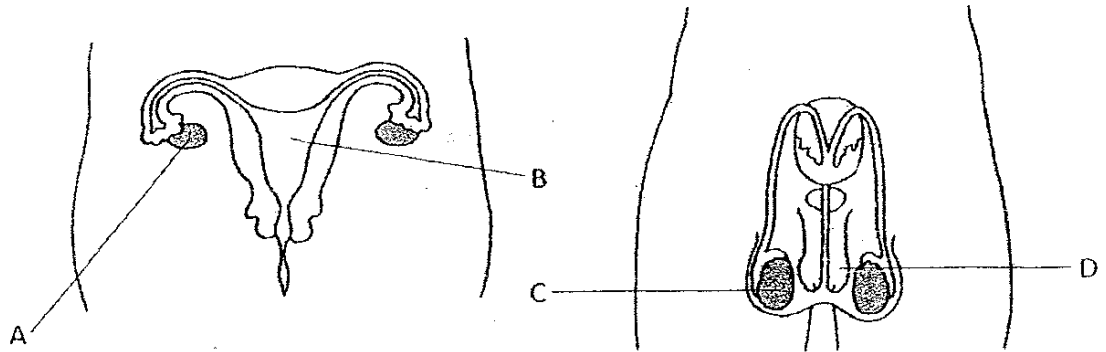

Which of the above parts will produce the cells that are necessary for reproduction to take place?

- | | |
|------------------|------------------|
| (1) A and C only | (2) A and D only |
| (3) B and C only | (4) B and D only |

5. Study the flowers of plants A and B as shown in the diagram below.

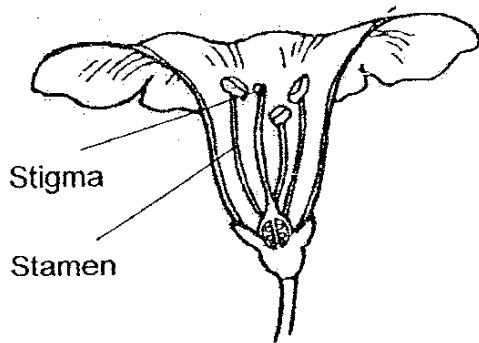

Flower of plant A

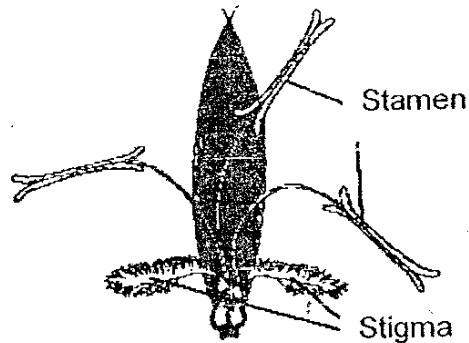

Flower of plant B

Based on the above diagrams, which of the following statements about the two species of flowers are true?

- A The flower of plant A possesses nectar or fragrance to attract insects.
- B The pollen grains in plant B has to be in large quantities so as to increase the chance of pollination.
- C The flower of plant B is most likely to have brightly-coloured petals as compared to the flower of plant A.
- D The stigma found in the flower of plant A is sticky and the stigma of the flower in plant B has a large surface area to catch the pollen grains.

- | | |
|---------------------|---------------------|
| (1) A and C only | (2) B and D only |
| (3) A, B and D only | (4) A, C and D only |

6. The diagram below shows the cross-section of a papaya.

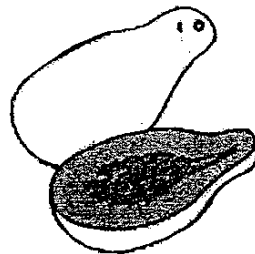

Which one of the following statements is most likely to be true about the flower from which this fruit has developed from?

- (1) The flower has many ovaries.
- (2) There are many ovules inside an ovary.
- (3) The fruit developed from a flower with male parts.
- (4) The flower did not go through pollination before the fruit was formed.

7. Yin Ling set up an aquarium as shown in the diagram below.

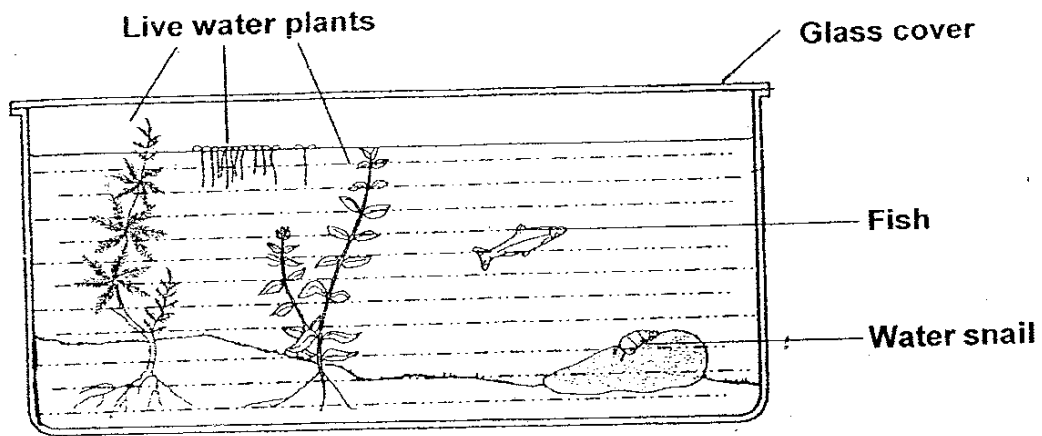

Other than food for the fish and water snail, which one of the following conditions must be present so that all the organisms living in the aquarium will live for the longest possible time?

- | | |
|--------------------|------------------------------|
| (1) Light | (2) Oxygen |
| (3) Carbon Dioxide | (4) Nutrients for the plants |

8. Raphaël conducted an experiment on photosynthesis and plotted his results as shown in the graph below.

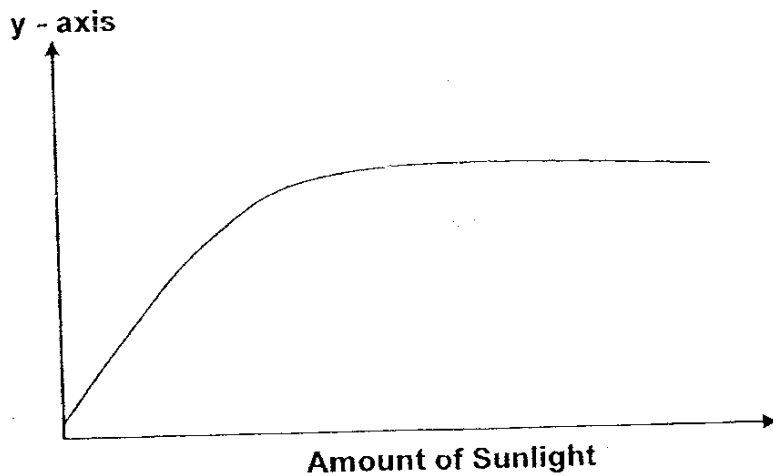

The y-axis of the graph is not labelled. Which one of the following would be a suitable label for the y-axis?

- (1) Rate of water absorption
- (2) Rate of production of oxygen
- (3) Rate of absorption of mineral salts
- (4) Rate of production of carbon dioxide

96

9. The diagram below shows the path of a ball after a boy has kicked it. Points P, Q and R are different positions along the path of the ball.

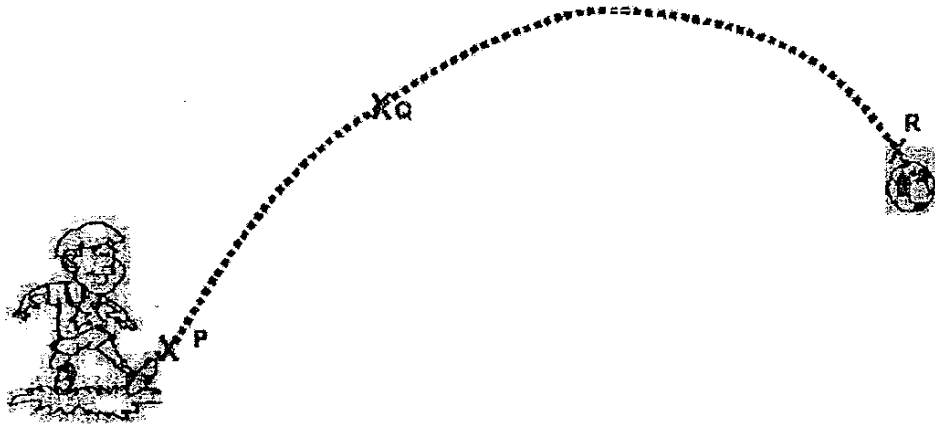

Which of the following statement(s) is/are true about the forces acting on the ball during its movement from P to R?

- A The kicking force at P is a push.
- B At point R, frictional force is acting upwards.
- C Gravitational pull did not act on the ball at point Q.
- D The forces acting on the ball caused it to change directions along the path.

- (1) A only
- (2) B and C only
- (3) A, B and D only
- (4) A, B, C and D

41

91

10. The flow chart below is used to classify forces A, B, C and D.

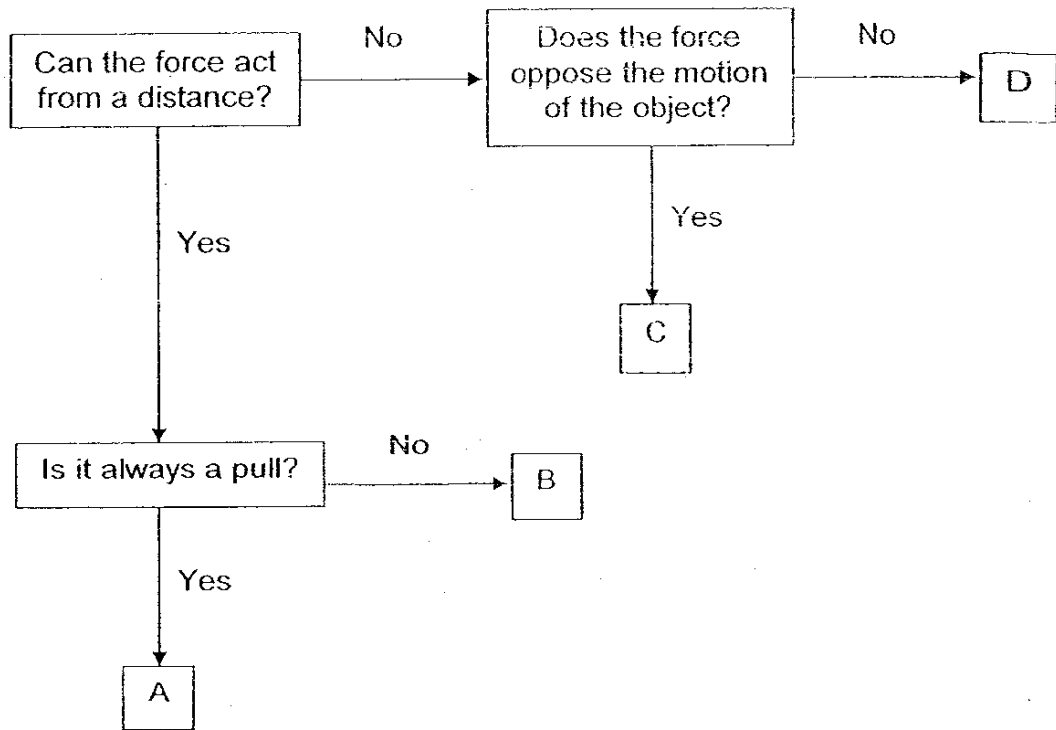

In which one of the following options are the 4 forces identified correctly?

	A	B	C	D
(1)	Gravity	Magnetic force	Push	Friction
(2)	Gravity	Magnetic force	Friction	Push
(3)	Magnetic force	Gravity	Friction	Push
(4)	Magnetic force	Gravity	Push	Friction

Handwritten marks: a star and the number 98.

11. The diagram below shows a claw hammer with a nail at position A.

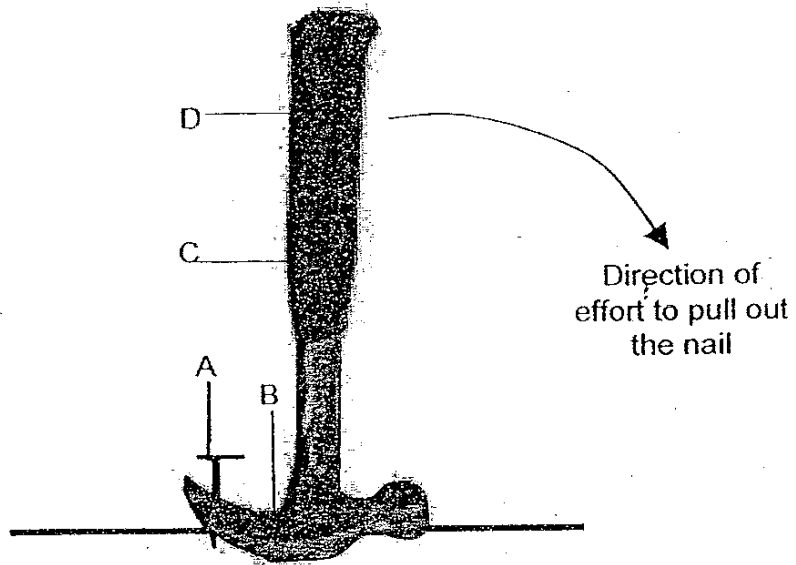

In which of the following situations will the least effort be required to pull out the nail?

	Nail is at Position	Effort is applied at Position
(1)	A	C
(2)	A	D
(3)	B	C
(4)	B	D

89

12. Joan carried out an investigation with 4 similar blocks, A, B, C and D, made from different materials. She lifted block A vertically upwards and pulled blocks B, C and D over pieces of plank with similar texture.

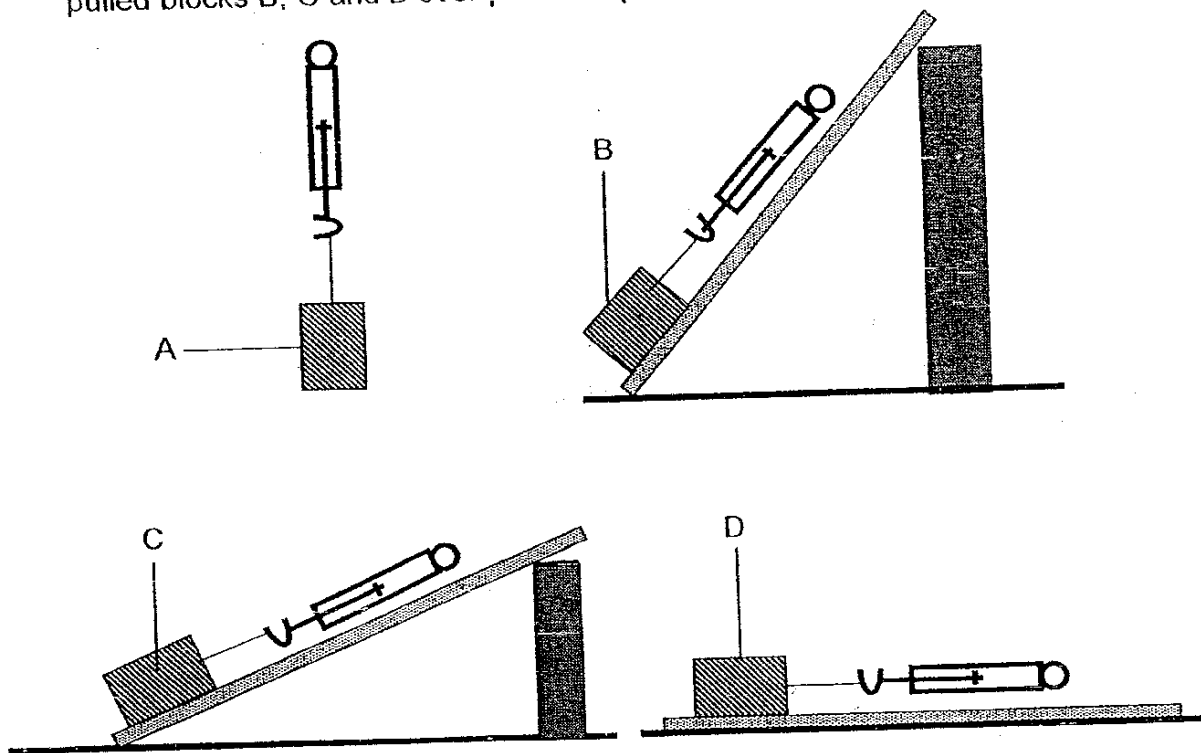

If all the spring balances recorded the same reading, which block is the heaviest?

- | | | | |
|-----|---|-----|---|
| (1) | A | (2) | B |
| (3) | C | (4) | D |

100

13. In which of the following set-up(s) would an effort of 8N be sufficient to lift the load?

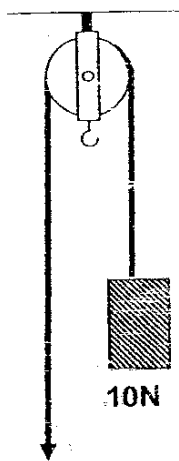

Set-up A

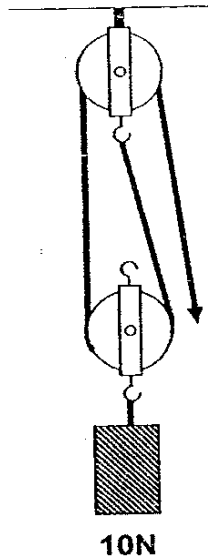

Set-up B

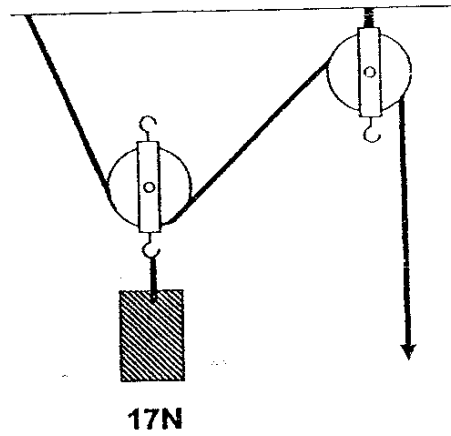

Set-up C

- (1) B only
 (2) A and C only
 (3) B and C only
 (4) A, B and C

14. In which one of the following gear systems would Gear C turn faster than, and in the same direction as Gear A?

(1)

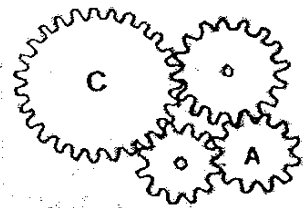

(2)

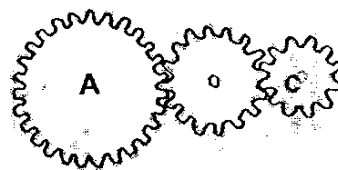

(3)

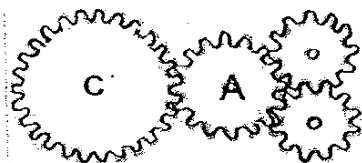

(4)

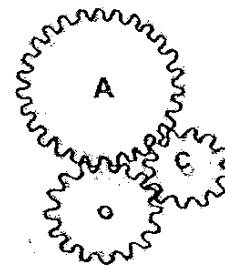

101

15. The diagrams below show a rolling pin and a screw driver.

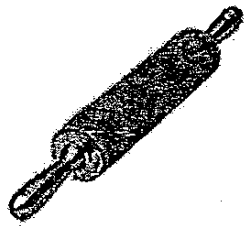

Which of the following statement(s) is/are **true** about both simple machines?

- A They change the direction of force(s).
- B They are examples of wheel and axle.
- C They reduce friction to make work easier.
- D They allow less effort to overcome the load.

- (1) B only
- (2) D only
- (3) A and D only
- (4) B and C only

16. Which of the following simple machine(s) help(s) us to do work easier by using a small movement of the effort to cause a large movement of the load?

(A) Ice tong

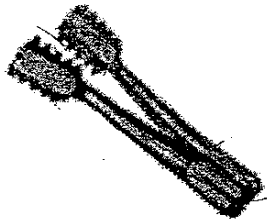

(B) Block and tackle

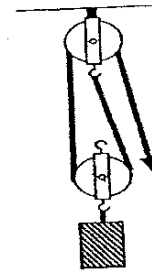

(C) Staircase

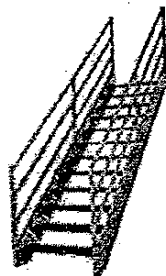

(D) Ceiling Fan

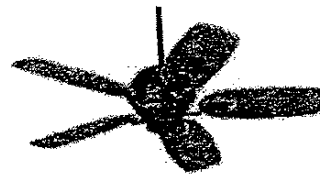

- (1) A only
- (2) A and D only
- (3) B and C only
- (4) B, C and D only

102

17. Peter has 3 rods, P, Q and R, made of different materials. He placed them in various positions, A, B and C, of the circuit shown below.

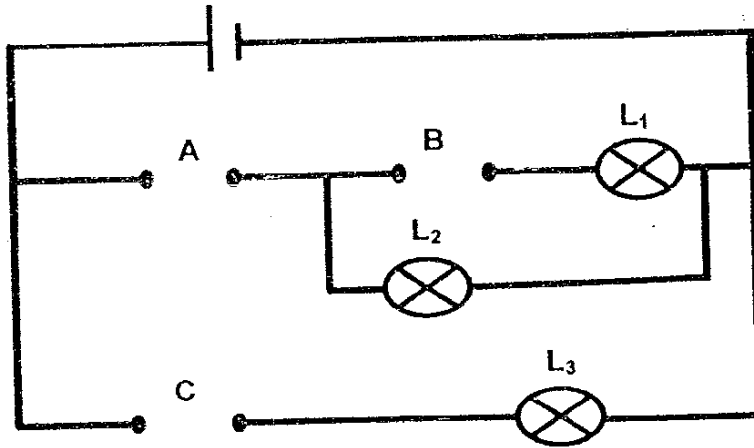

The results of the experiment were shown in the table below. When any of the lamps, L_1 , L_2 , or L_3 , lit up during the experiment, a tick (✓) was placed in the box.

Position where rods were placed			Lamp		
A	B	C	L_1	L_2	L_3
P	Q	R	✗	✓	✓
Q	R	P	✗	✗	✓

Based on the above results, which one of the following classifications of the materials, P, Q and R, according to their electrical conductivity is correct?

	Conductor(s) of electricity	Insulator(s) of electricity
(1)	R	P, Q
(2)	Q	P, R
(3)	P, Q	R
(4)	P, R	Q

18. In which of the following circuits would **only** 2 bulbs light up?

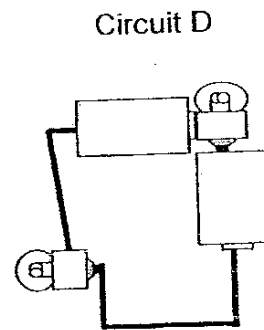
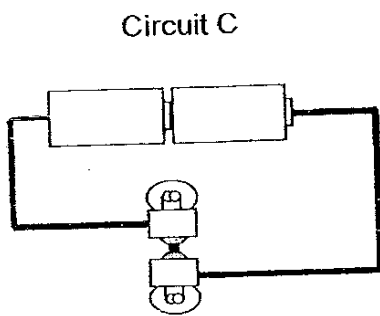
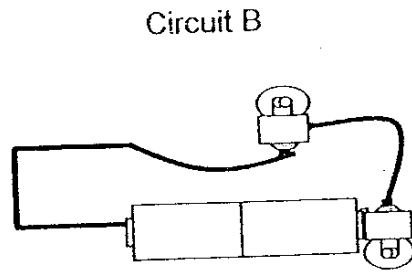
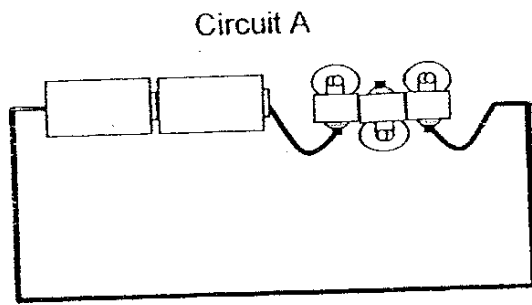

- | | |
|---------------------|---------------------|
| (1) A and D only | (2) B and D only |
| (3) A, B and D only | (4) A, C and D only |

19. Which of the following is/are source(s) of electricity?



A : Two-pin plug



B : Electric eel



C : Lightning

- | | |
|------------------|----------------|
| (1) A only | (2) B only |
| (3) B and C only | (4) A, B and C |

104

22. Peter used some new batteries, wires and 3 similar iron nails to make 3 electromagnets as shown below. The number of turns of the wire around the nails is stated in each set-up.

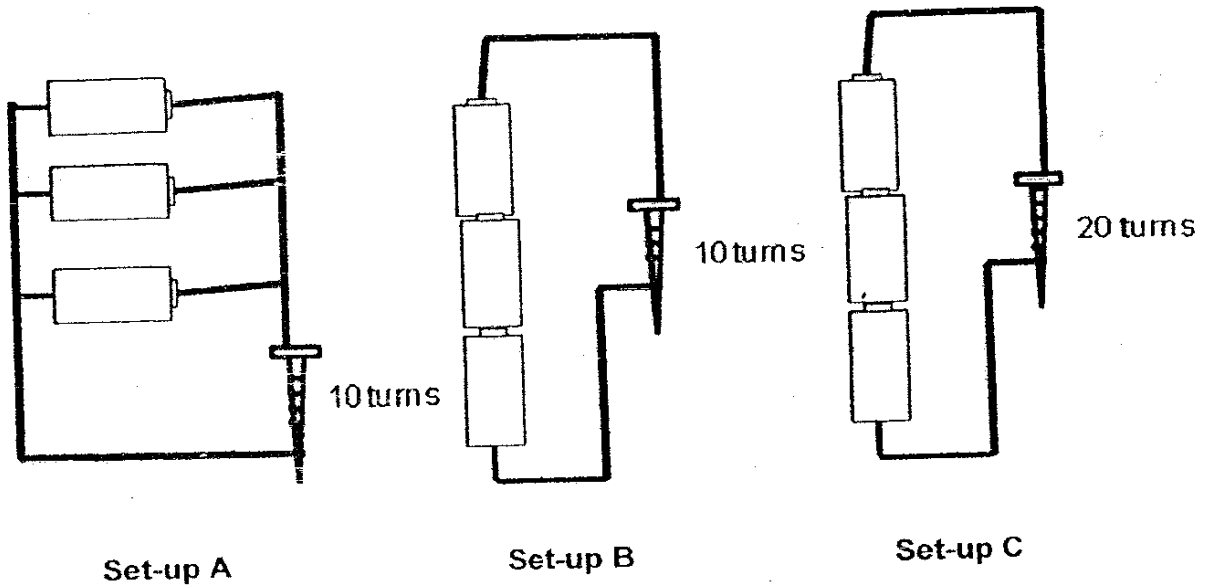

If Peter wished to study how the arrangement of the batteries and the number of turns of wire around the nail affect the strength of the electromagnet, which set-ups should he use?

	To study how the arrangement of batteries affect the strength of electromagnet	To study how the number of turns of wire around nail affect the strength of electromagnet
(1)	Set-ups A and B	Set-ups A and C
(2)	Set-ups A and C	Set-ups B and C
(3)	Set-ups A and B	Set-ups B and C
(4)	Set-ups B and C	Set-ups A and B

106

23. Mary used new batteries and bulbs of similar voltage to set up 4 circuits as shown below.

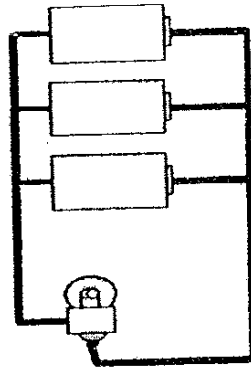

Set-up A

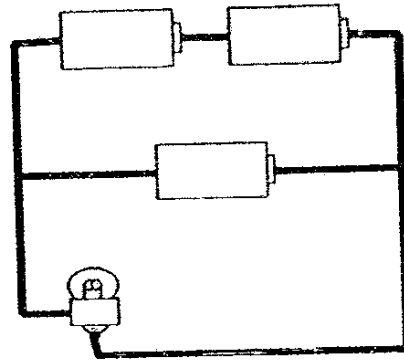

Set-up B

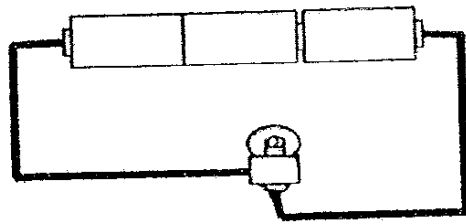

Set-up C

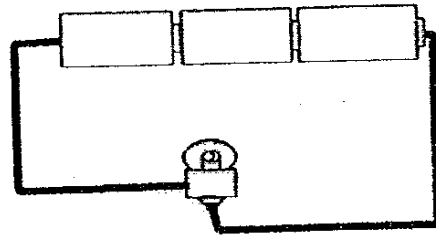

Set-up D

In which set-up would the bulb be the brightest?

- (1) A
- (3) C

- (2) B
- (4) D

107

24. The diagram below shows a circuit set up by Bala. The sides of the wooden box were marked P and R, and there was an object inside the box.

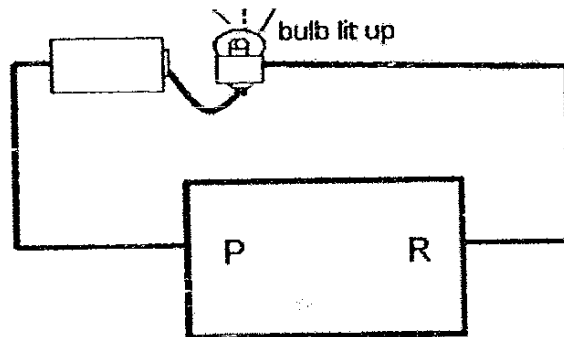

Which of the following show the objects in the box that would light up the bulb?

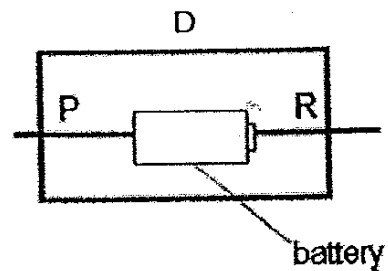
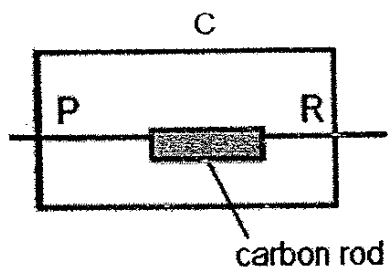
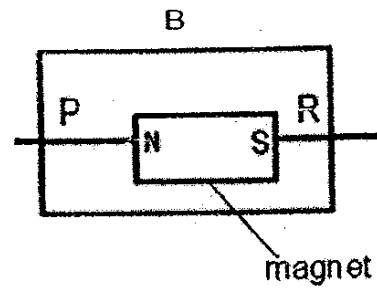
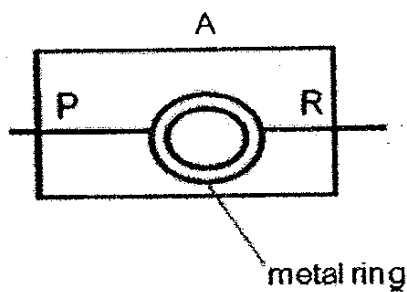

- (1) A and B only
 (2) C and D only
 (3) A, B and C only
 (4) A, B, C and D

108

25. The diagram below shows part of the human lungs.

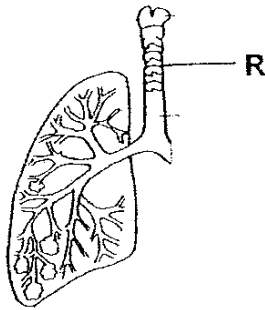

The inner part of tube R is lined with tiny hairs called the cilia. These tiny hairs are especially important if the air that you breathed in is polluted as they _____.

- (1) widen the size of the tube
 - (2) moisten the air leaving and entering the lungs
 - (3) assist in gaseous exchange that will take place in the lungs
 - (4) trap dust and other particles that entered the nose with the air taken in
26. The table below shows the composition of four samples of air. Which one of the following samples could **most likely** have been breathed out by a person who was doing vigorous exercises?

Sample	Composition of Air (%)		
	Carbon Dioxide	Oxygen	Water Vapour
(1)	4	21	0.005
(2)	4	16	0.5
(3)	0.03	21	0.5
(4)	0.03	16	0.005

109

27. A group of pupils wanted to find out if balsam plants can absorb water without the roots. The diagram below shows the control for this experiment.

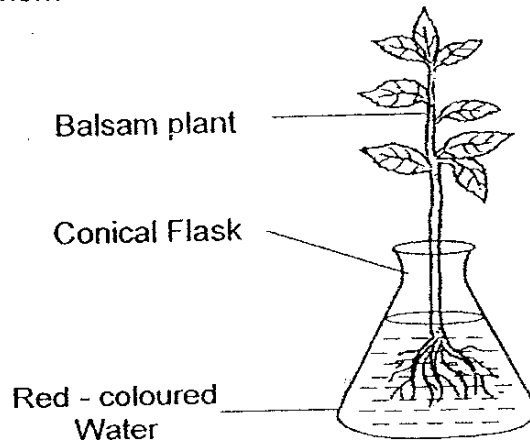

What are the variables that they should keep constant for their experimental set-up?

- A Type of plant
- B Number of leaves
- C Presence of roots
- D Amount of coloured water

- (1) A, B and C only
- (3) B, C and D only

- (2) A, B and D only
- (4) A, B, C and D

28. In which of the following part(s) of the body can the ball-and-socket joint be found?

- A Hips
- B Knees
- C Elbows
- D Shoulders

- (1) A only
- (3) A and D only

- (2) C only
- (4) B and C only

29. Which one of the following parts of the skeletal system is **not** correctly matched to its intended function?

	Part of the Skeletal System	Function
(1)	Skull	Protects the brain
(2)	Backbone	Protects the spinal cord
(3)	Rib cage	Protects the heart and lungs
(4)	Hip bone	Protects the muscles in the lower part of the body

30. The following diagram shows the state of muscles, A and B, when the arm is bent.

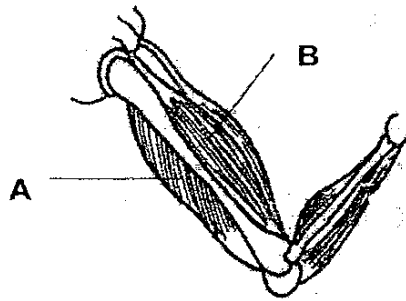

Based on the above diagram, which one of the following options describes correctly the muscles when the arm is **straightened**?

	Muscle A	Muscle B
(1)	Contract	Relax
(2)	Contract	Contract
(3)	Relax	Relax
(4)	Relax	Contract



南洋小學

NANYANG PRIMARY SCHOOL

PRIMARY FIVE SCIENCE

SEMESTRAL ASSESSMENT 2

2007

BOOKLET B

Date : 26 October 2007

Duration : 1 h 45 min

Name : _____ ()

Class: Primary 5 ()

Marks Scored:

Booklet A:		60
Booklet B :		40
Total :		100

Parent's signature:

DO NOT OPEN THIS BOOKLET UNTIL YOU ARE TOLD TO DO SO.
FOLLOW ALL INSTRUCTIONS CAREFULLY.

Booklet B consists of 17 printed pages including this cover page.

112

Section B (40 marks)

Write your answers to questions 31 to 46 in the spaces provided.
Marks will be deducted for misspelt key words.

31. The pictures below show some animal and plant cells.

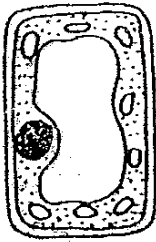

Cell A



Cell B

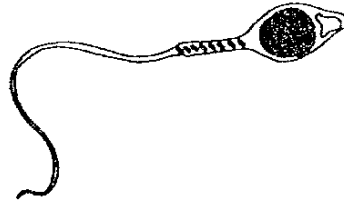

Cell C

- (a) Which one of the above cells is needed for fertilization to take place? (1 mark)

-
- (b) Which one of the above cells could most likely make food for the plant? Give a reason for your answer. (2 marks)

32. Study the following cells carefully.

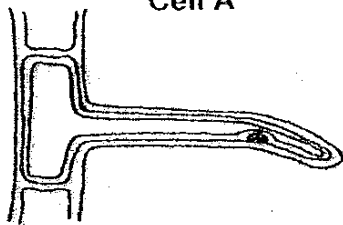

Cell A

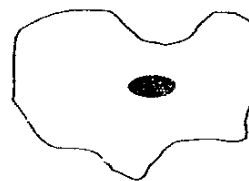

Cell B

Based on the above diagrams, give a difference and a similarity between the 2 cells above. (Do not compare the size and colour.) (2 marks)

Similarity -

Difference -

33. The diagram below shows a process that the human cell undergoes.

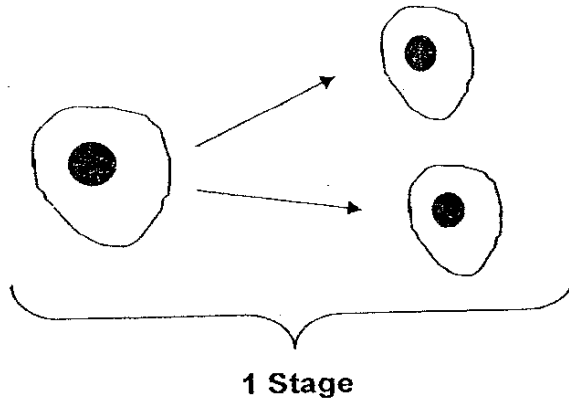

- (a) Name the above process. (1 mark)

- (b) How many stages must the cells undergo so that there will be 64 cells after some time? (1 mark)

34. Study the following diagram.

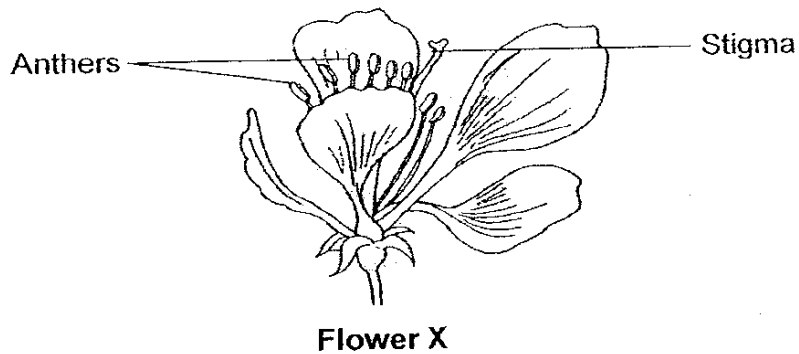

- (a) How is flower X most likely to be pollinated? (1 mark)

- (b) Based on the diagram, how is the chance of self-pollination reduced in this plant? (1 mark)

35. The diagrams below show 2 fruits, X and Y (not drawn to scale).

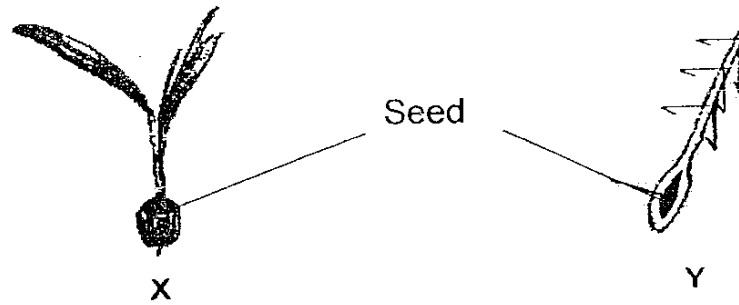

In the table below, suggest how the two fruits are likely to be dispersed and state the structures that help them in their dispersal. (2 marks)

Fruit	Method of Dispersal	Structures
X		
Y		

115

36. Rafi was given the following set-ups to find out if oxygen is required for respiration to take place in the peas.

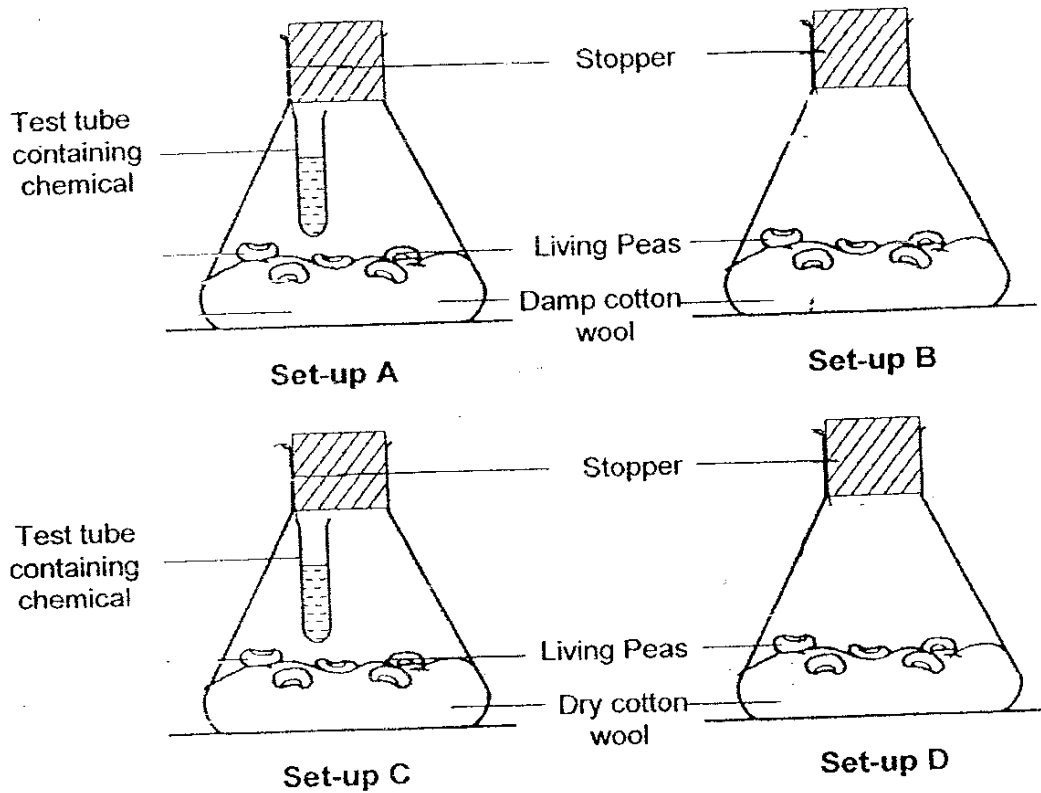

The chemicals in Set-ups A and C are used to remove oxygen.

- a) He chose to use Set-ups A and C for his experiment. His teacher told him that he had made the wrong choices. Give a reason why his choices were wrong. (1 mark)

- b) Which of the above set-ups should he use instead to verify the aim of the experiment? (1 mark)

- c) If he were to use Set-ups B and D to conduct another experiment, what would be the aim of his new experiment? (1 mark)

37. The following diagram shows a representation of a particular food web in a habitat. Organisms A to I represent the organisms in this food web.

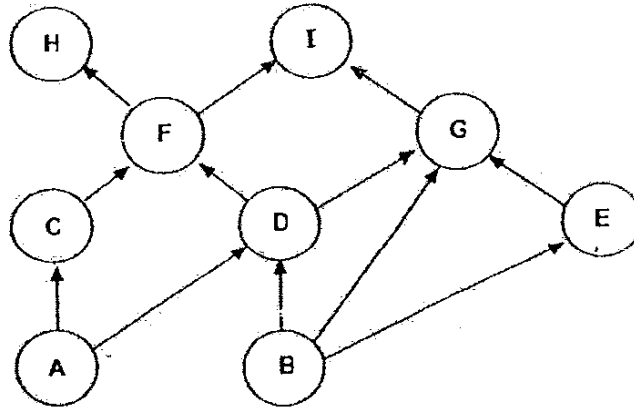

- (a) Based on the above diagram, organism A is a food producer. Which other organism is also a food producer? (1 mark)
- _____
- (b) Organism C feeds on plants. What is the diet of organism G? (1 mark)
- _____
- (c) If the population of organism F was wiped out due to a disease, which **population(s)** will decrease greatly first? (1 mark)
- _____
- (d) Based on the above diagram, write down a complete food chain that involves **only 3** organisms. (1 mark)
- _____

38. Jack placed some sand into a plastic container. He measured the temperature of the sand before covering the container. Then he shook the container for 5 minutes and measured the temperature of the sand immediately after.

(a) Explain why the temperature of the sand was higher after shaking. (1 mark)

(b) What is the effect on the temperature of the sand if some oil was added to it before it was shaken for 5 minutes? (1 mark)

118

39. The diagram below shows a toy which Siti had made with a block and a balloon. 50 cm³ of air was pumped into the balloon and it was then released. The distance, *d*, moved by the toy was measured.

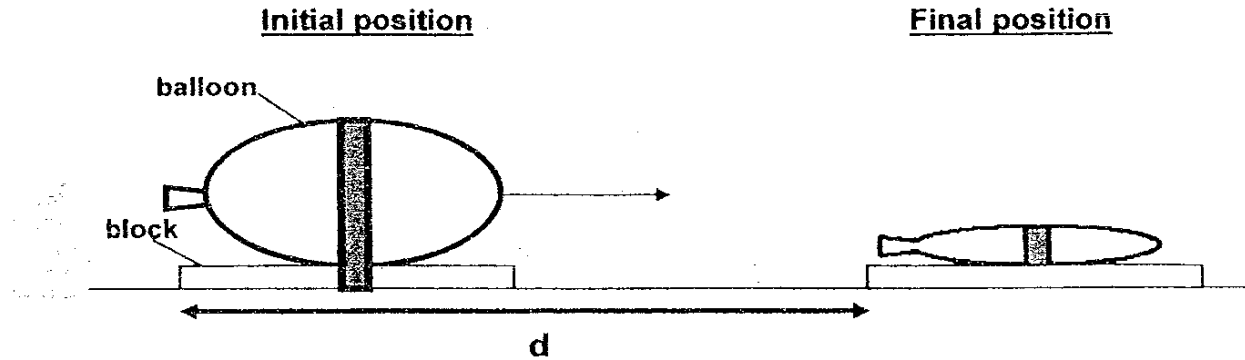

The table below shows the data collected for different amounts of air pumped into the balloon. The distance, *d*, was not measured when 150 cm³ of air was pumped into the balloon.

Amount of air (cm ³)	Distance, <i>d</i> (cm)
50	20
100	34
150	?
200	86

- (a) Explain why Siti should have taken 3 readings of '*d*' for each volume of air pumped into the balloon. (1 mark)

- (b) What would the distance, *d*, most likely be when 150 cm³ of air was pumped into the balloon? (1 mark)

(Turn over to the next page for part (c) of the question)

119

The experiment was repeated with the toy moving up a ramp. The distance, e , moved by the toy was measured.

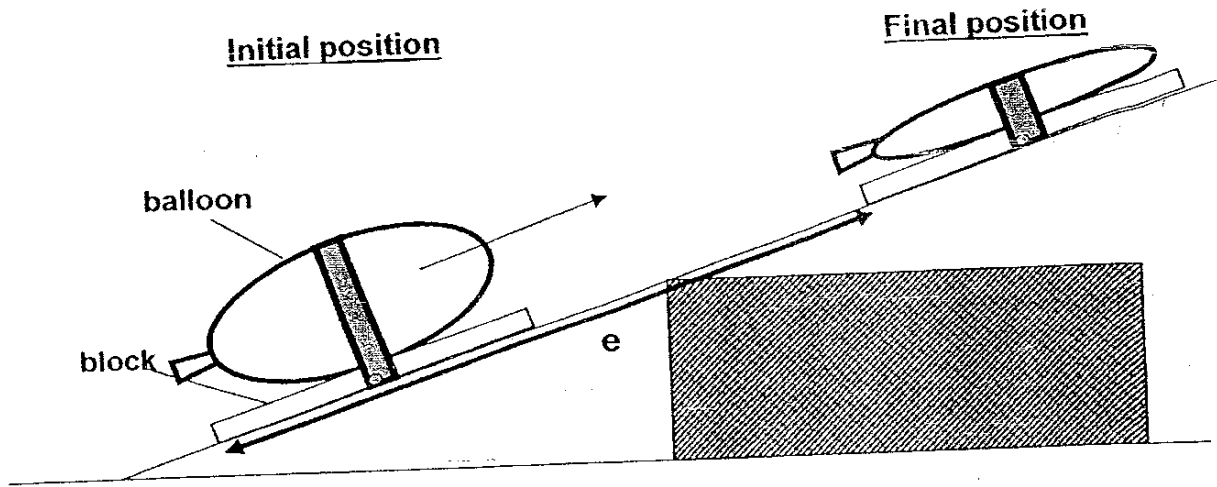

- (c) When 100 cm^3 of air was pumped into the balloon and released, the distance, e , was lesser than 34 cm. Give a reason why this is so. (1 mark)

120

40. The diagram below shows the side-view of a wheel and axle.

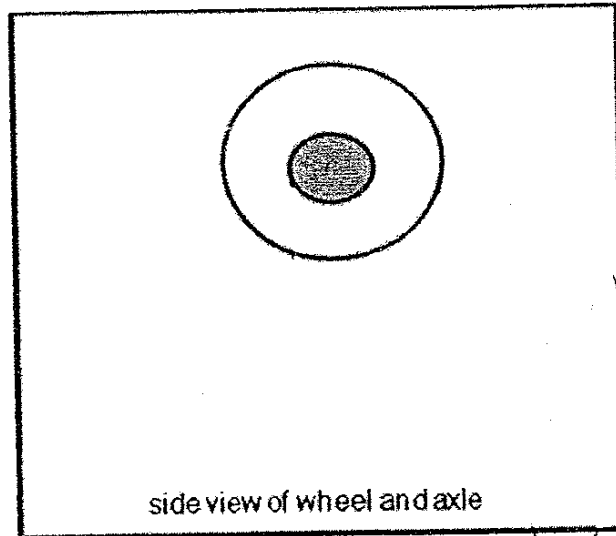

- (a) Use the 2 symbols below to **complete** the diagram of the wheel and axle above, to show how **less** effort is used to overcome the load. (1 mark)

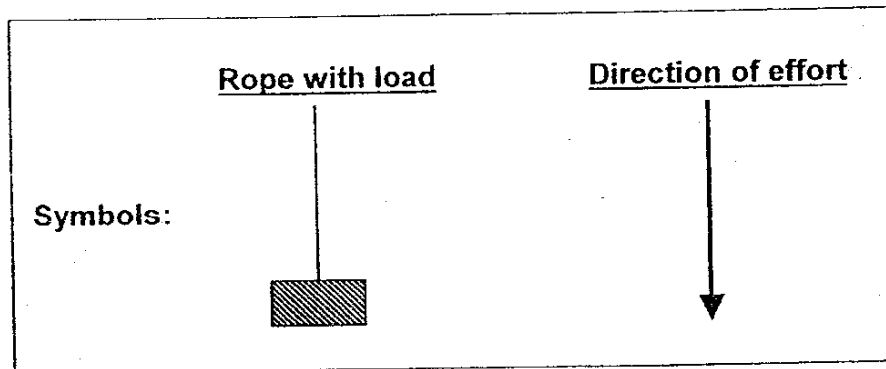

- (b) Based on your answer in part (a), state one **disadvantage** of using such a wheel and axle. (1 mark)

121

41. The set-up below was used by Jill to investigate how the weight hung at the end would affect the length of the spring, T.

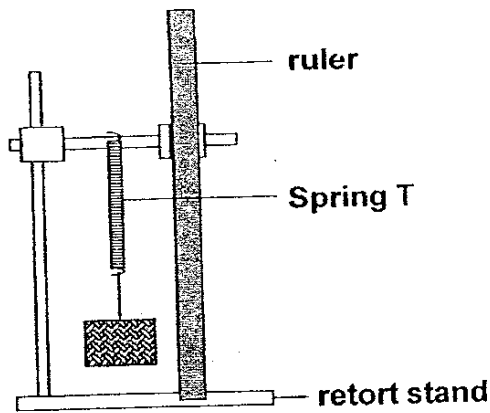

Jill hung different weights at the end of the spring and measured the length of the spring.

After she had collected her data, she plotted a graph as shown below.

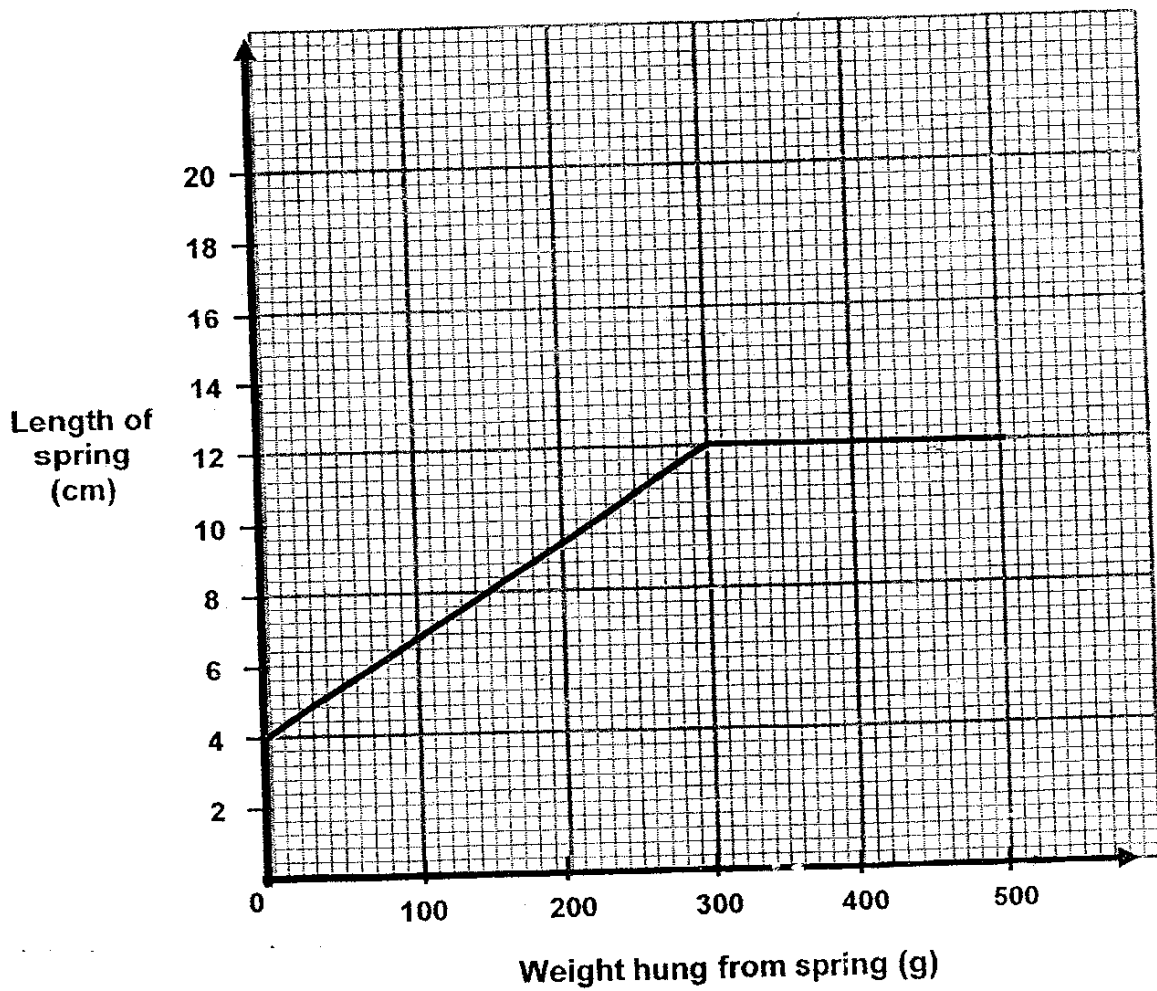

- (a) Based on the graph, what was the length of spring T before any weight was hung from it? (1 mark)

- (b) Jill repeated the experiment using the same set-up but with a different spring, U.

The original length of spring U was 6 cm and it became permanently stretched when a 400 g weight was hung from it.

Spring U had also stretched more than spring T when the same weights were hung from both springs.

On the graph below, draw a line graph to show the results that Jill would obtain for spring U. (2 marks)

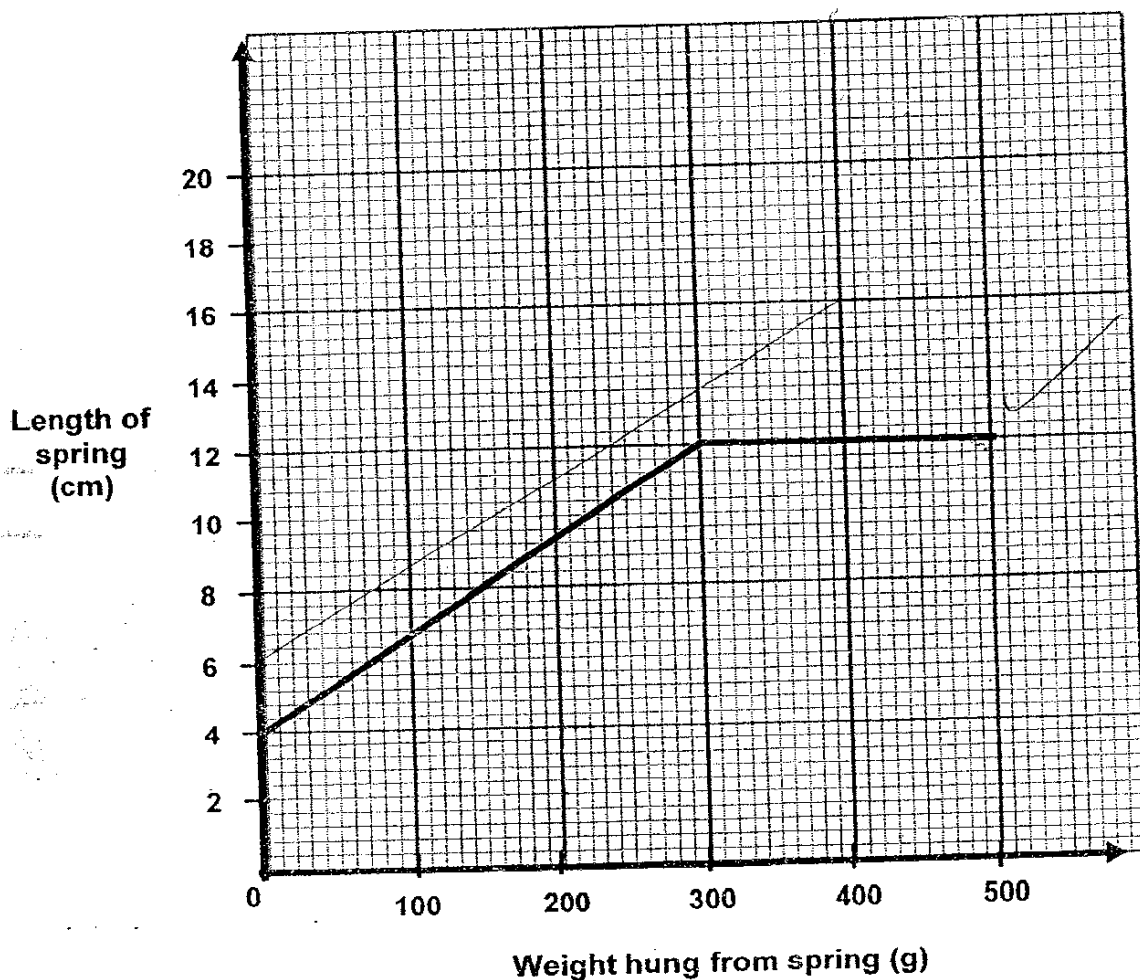

42. Leela was told that the thread of a screw is an inclined plane. She carried out an investigation to find out the relationship between the number of turns of the thread and the steepness of the inclined plane wrapped round the screw.

She wrapped 2 different pieces of triangular paper around a pencil and counted the number of turns as shown in the diagrams below.

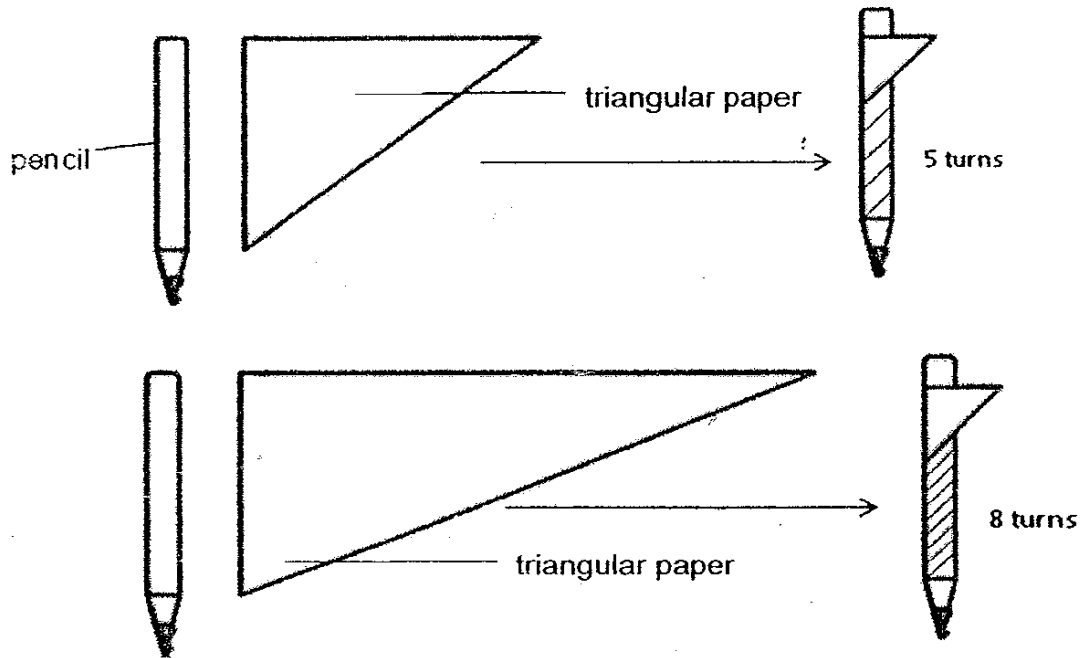

- (a) From her investigation, what could she conclude about the number of turns of the thread on a screw and the steepness of the inclined plane of the screw? (1 mark)

(Turn over to the next page for parts (b) and (c) of the question)

124

Leela was given the three screws A, B and C as shown below to conduct a second experiment.

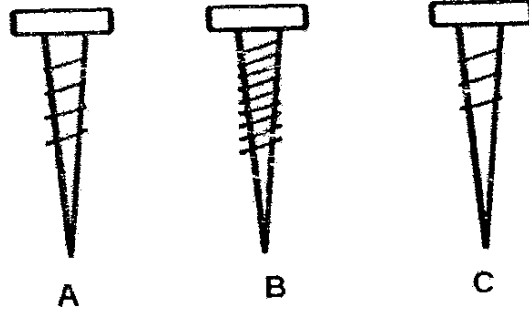

- (b) Which screw would require the least effort when Leela used the same screwdriver to screw them into a block of wood? Give a reason for your answer. (2 marks)

- (c) Inclined plane is one of the two simple machines used in a screw. What is the other simple machine? (1 mark)

125

43. Study the circuit tester and circuit card below.

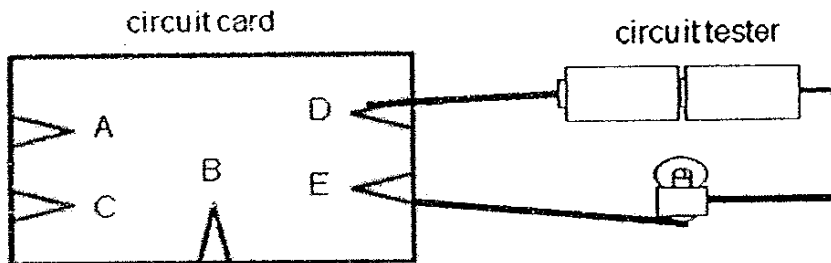

A, B, C, D and E are 5 contact points on the circuit card. The wires underneath the circuit card are not shown. When the ends of the 2 wires of the circuit tester are connected to contact points, the bulb is either lit or unlit.

The table below shows the results obtained when different pairs of contact points were connected to the circuit tester.

Points connected to circuit tester	Observation
D and E	bulb unlit
C and A	bulb lit
B and E	bulb unlit
A and D	bulb lit
A and B	bulb unlit

- (a) In the diagram below, draw **only 2** lines to represent the wires that connect the contact points for the above observations. (1 mark)

Circuit card

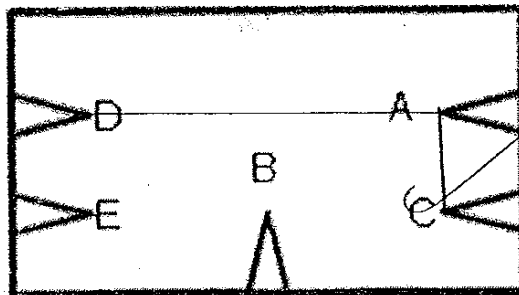

- (b) Explain why the circuit card is not made of metal. (1 mark)

44. Jimmy wanted to find out which liquids conduct electricity. He set up the apparatus as shown below. He replaced the batteries and metal plates for each time a new liquid was tested.

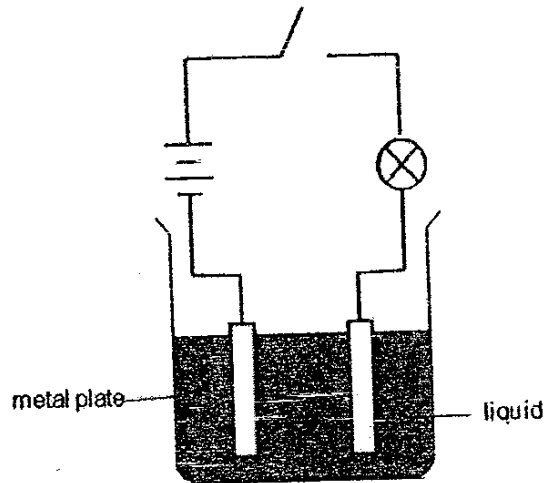

The following observations were obtained.

Bulb lit up	Bulb did not light up
Seawater Vinegar	Pure water Cooking oil

- (a) State 1 variable that must be kept constant for a fair experiment. (1 mark)

- (b) Jimmy inferred that seawater is a better conductor of electricity than vinegar. What could he have observed to make this inference? (1 mark)

127

45. The table below shows a simple comparison between an artery and a vein in a human body.

	Types of Blood Vessels	
	Artery	Vein
Thickness of muscle in vessel	Thick	Thin
Composition of dissolved gases	Rich in oxygen	Rich in carbon dioxide

Based on the above table, the muscular tissue found in the artery is thick as compared to the vein. Explain why the layer of muscle in the artery must be thick. (2 marks)

46. What is the difference in the composition of dissolved gases in the blood leaving the lungs as compared to the blood that is entering the lungs? (2 marks)

(i) Blood leaving the lungs - _____

(ii) Blood entering the lungs - _____

-----END OF PAPER-----

Setters: Mr Pang Kia Keng
Mrs Rachel Tan

128

Nanyang Primary School
Primary 5 Science SA2 Exams (2007)

Answer Keys

SECTION A : (60 MARKS)

Qn no.	Ans
1	3
2	4
3	2
4	1
5	3
6	2
7	1
8	2
9	3
10	2

Qn no.	Ans
11	4
12	4
13	1
14	2
15	1
16	2
17	4
18	4
19	3
20	4

Qn no.	Ans
21	4
22	3
23	4
24	3
25	4
26	2
27	2
28	3
29	4
30	1

SECTION B (40 MARKS)

- 31a. Cell C.
 31b. Cell A, there are chloroplast in cell A.
32. Similarity: They have nucleus.
 Difference: Cell A has a fixed shape but cell B does not have a fixed shape.
- 33a. Cell division is taking place.
 33b. 6 stages.
- 34a. By animals
 34b. The stigma is higher than the anthers.
35. X: By wind, Wing-like structure
 Y: By animals, hooks on the fruit.
- 36a. There is no control experiment comparison of results since there was no oxygen in both setups.
 36b. He wanted to find out if the peas need water to germinate.
- 37a. Organism B
 37b. Both plants and animals
 37c. Organism H
 37d. Organism B → Organism G → Organism I

- 38a. Shaking the sand caused friction between the sand thus heat was produced.
 38b. The temperature will be higher than before shaking.

- 39a. So that it is more accurate.
 39b. 52 cm
 39c. The balloon goes up wards the ramp but the gravitational force pulls it down, therefore, lesser distance is moved by the balloon.

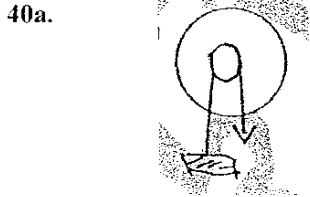

- 40b. The effort moves a longer distance than the load.

- 41a. 4 cm.
 41b.

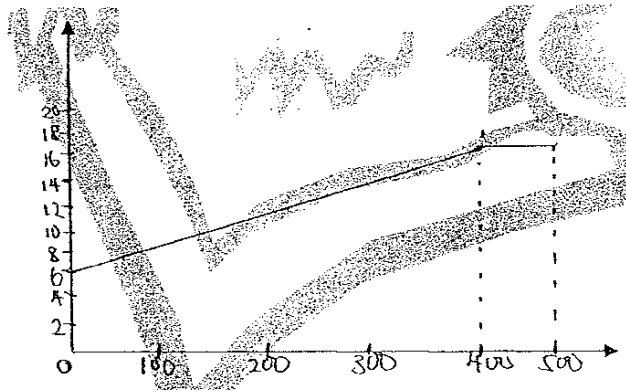

- 42a. The lesser the thread, the steeper it is.
 42b. The lesser the number of threads on a screw the steeper the slope.
 42c. Wheel and axle

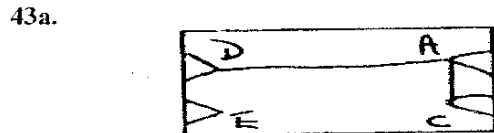

- 43b. So that it does not conduct electricity. If it a metal and conduct electricity, wherever the wire touches on the circuit card, the bulb would lit up.

- 44a. Number of batteries.
- 44b. The bulb lit up brighter when testing in sea water than in vinegar.
45. The Artery is thick so that more energy can be carried to all parts of our body.
46. (i) Rich in oxygen.
(ii) Rich in carbon dioxide.