

# Anglo-Chinese School (Junior)



## SEMESTRAL ASSESSMENT 1 (2016)

PRIMARY 5

SCIENCE

BOOKLET A

Tuesday

10 May 2016

1 hr 30 min

Name: \_\_\_\_\_ ( ) Class: 5.( )

### INSTRUCTIONS TO PUPILS

- 1 Do not turn over the pages until you are told to do so.
- 2 Follow all instructions carefully.
- 3 There are 25 questions in this booklet.
- 4 Answer ALL questions.
- 5 Shade your answers in the Optical Answer Sheet (OAS) provided.

---

This question paper consists of 17 printed pages (inclusive of cover page).

**Booklet A (50 marks)**

For each question from 1 to 25, four options are given. One of them is the correct answer. Choose the correct option (1, 2, 3 or 4) and shade the correct oval on the Optical Answer Sheet (OAS). (25 x 2 marks)

1 Study the flowchart below.

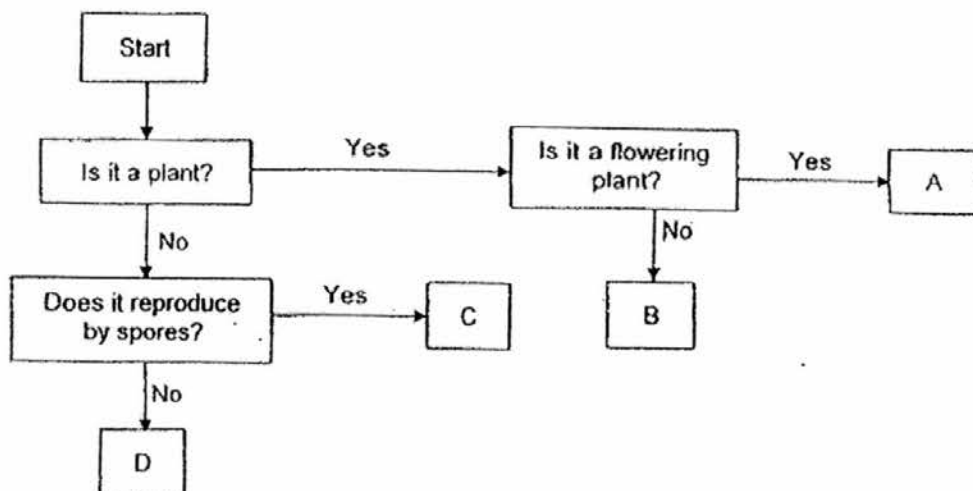

Which of the following can be organisms, A, B, C and D?

	A	B	C	D
(1)	Mould	Balsam	Bacteria	Hibiscus
(2)	Balsam plant	Mould	Bracket Fungi	Bacteria
(3)	Hibiscus plant	Bird's nest fern	Bacteria	Toadstool
(4)	Hibiscus plant	Moss	Bracket Fungi	Bacteria

- 2 A mimosa plant, as shown below, will fold its leaves when touched or exposed to heat.

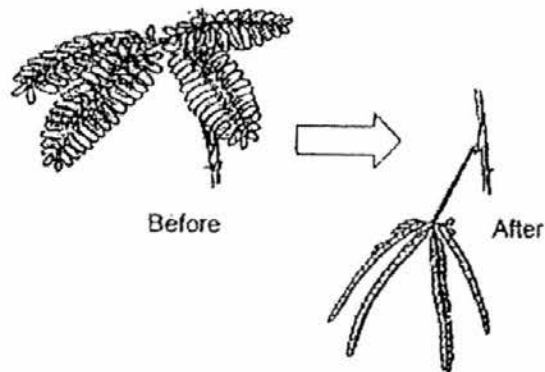

This shows that the mimosa plant is a living thing because it can \_\_\_\_\_.

- (1) grow
  - (2) reproduce
  - (3) respond to changes
  - (4) move freely from place to place.
- 3 Aaron, Ben, Caleb and Donovan were each given an identical piece of clay. They each conducted a simple experiment to show that the clay has volume.

Name	Experiment
Aaron	Molded and shaped it into many different shapes.
Ben	Placed it on a weighing scale and measured its mass.
Caleb	Placed it in a sunny spot in the garden and let it dry up.
Donavan	Placed it in a beaker of water and observed the change in the water level in the beaker.

Whose experiment best shows that the clay has volume?

- (1) Aaron
- (2) Ben
- (3) Caleb
- (4) Donovan

- 4 The diagrams below show the growth of a bean plant.

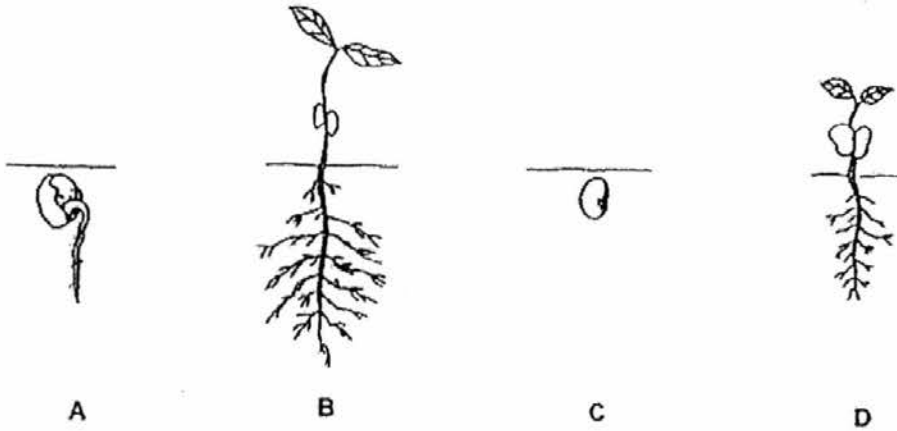

Which of the following shows the correct order of the growth of the bean plant?

- (1) C → B → D → A  
 (2) C → D → B → A  
 (3) C → B → A → B  
 (4) C → A → D → B
- 5 The table below shows the properties of 3 types of matter.

Property	X	Y	Z
Does it have a definite shape?	No	No	Yes
Can it be compressed?	No	Yes	No
Can it be seen?	Yes	No	Yes

Which of the following correctly identifies X, Y and Z?

	X	Y	Z
(1)	oxygen	water	glass marble
(2)	water	glass marble	oxygen
(3)	water	oxygen	glass marble
(4)	glass marble	oxygen	water

- 6 Calvin placed two objects, X and Y, which were made of different materials, on a balance. He observed that the balance tilted towards its left, as shown in the diagram below.

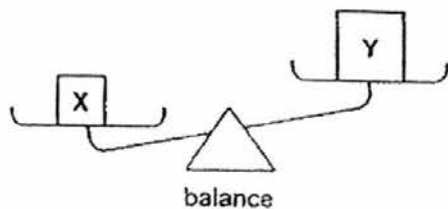

Based on his observation, which of the following conclusions can Calvin make?

- A X has a greater mass than Y.
- B Y occupies more space than X.
- C Both do not have definite shape.
- D X is lighter than Y because it is smaller.

- (1) A and B only
- (2) B and C only
- (3) C and D only
- (4) A and D only

- 7 Mark had four magnets, P, Q, R and S, suspended on strings. He brought the magnets close to a box of thumbtacks as shown in the diagram below. All the magnets were placed an equal distance away from the thumbtacks.

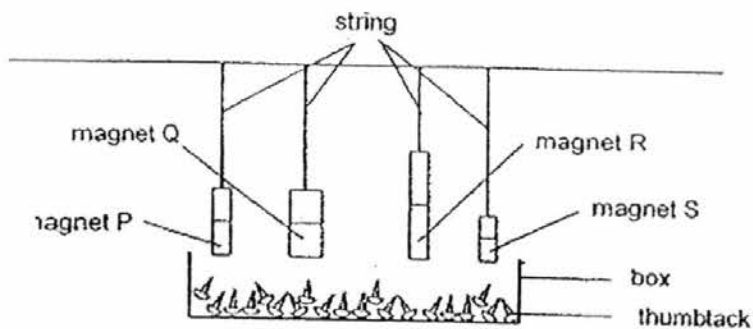

He observed the number of thumbtacks that each magnet was able to attract and recorded his findings in the table below.

Magnet	P	Q	R	S
Number of thumbtacks attracted	2	5	3	7

Based on the results in the table, which of the following is the best / most likely conclusion Mark can make?

- (1) Small magnets are weaker than big magnets.
- (2) Shorter magnets are weaker than longer magnets.
- (3) The strength of a magnet is dependent on its length.
- (4) The strength of a magnet is not dependent on its size.

- 8 Tom carried out an experiment involving an iron bar, an aluminium sheet and a magnet as shown in the diagram below.

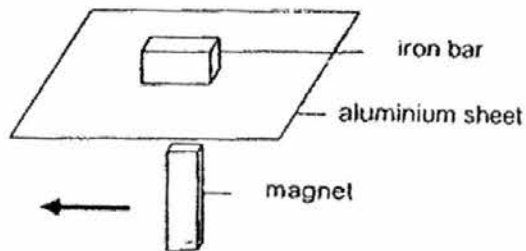

When Tom held the magnet a distance below the aluminium sheet and moved it in the direction of the arrow, the iron bar moved in the same direction as the magnet.

Based on his observations, which of the following conclusions can Tom make?

- A Iron is a magnetic material.
- B Like poles of two magnets repel.
- C Magnetic attraction can act from a distance.
- D Magnetic attraction can pass through magnetic material.

- (1) A and C only
- (2) B and C only
- (3) B and D only
- (4) A and D only

- 9 Which of the following shows the correct way of making an iron nail into a temporary magnet?

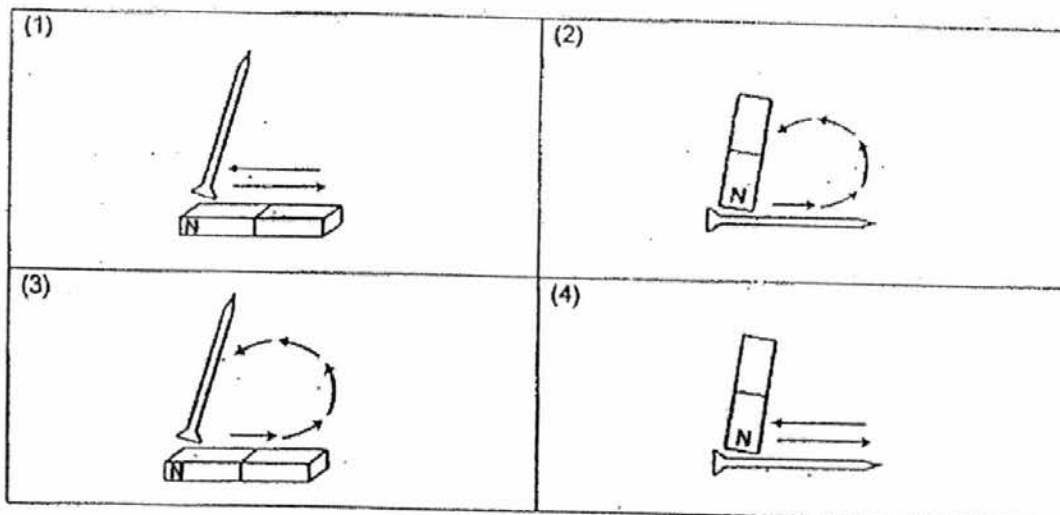

- 10 Three bar magnets PQ, RS and XY are arranged as shown below.



Which one of the following arrangement of magnets is not possible?

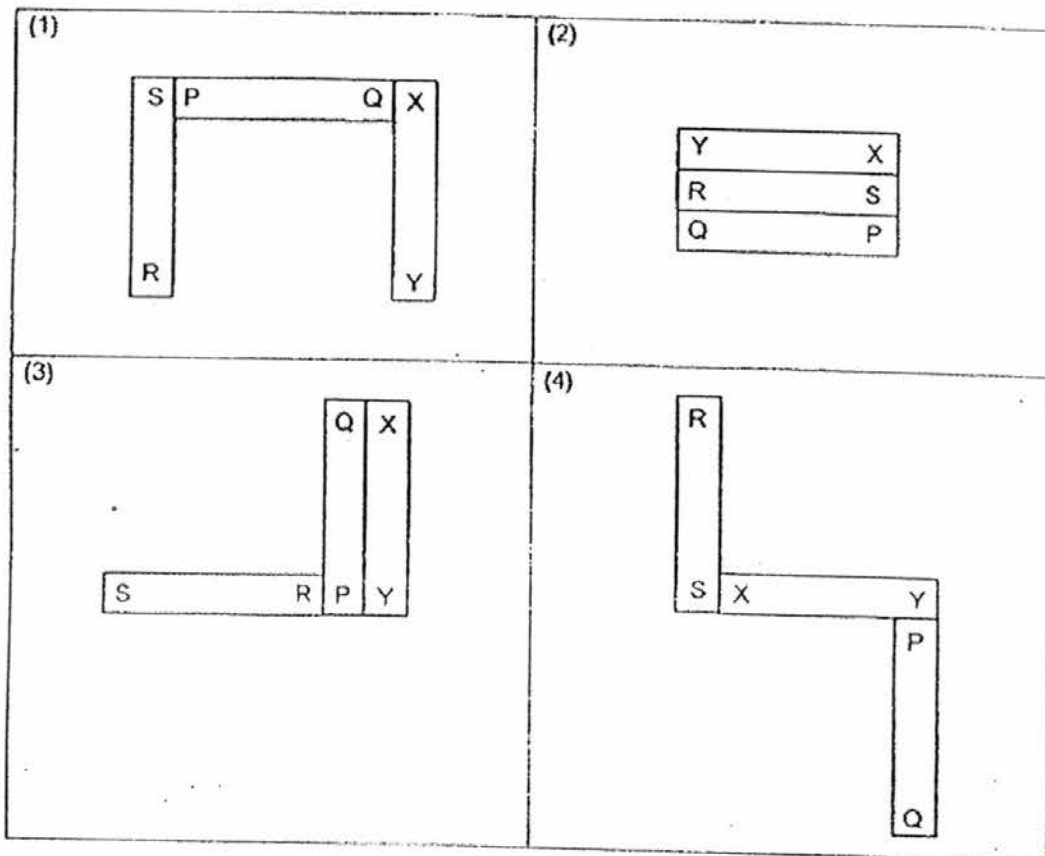

- 11 The diagram below shows the human digestive system.

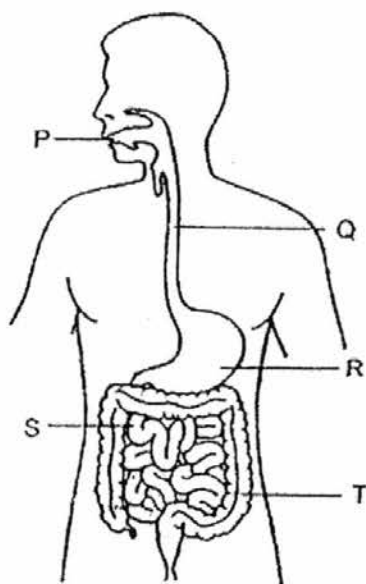

In which parts of the digestive system are digestive juices present to help with the breaking down of food into simpler substances?

- (1) P and R only  
 (2) Q, R and T only  
 (3) P, R and S only  
 (4) P, Q, S and T only
- 12 Dillon coated the underside of a few leaves from a potted plant with a thick layer of oil. He placed the plant in a sunny spot in the garden and continued to water it daily.
- After a week, he noticed that all the leaves that were coated with oil turned yellow while the leaves that were not coated with oil remained green and healthy.
- What could be the reason for the leaves that were coated with oil to turn yellow?
- (1) They absorbed the sunlight and turned yellow.  
 (2) They were not able to absorb the water vapour in the air.  
 (3) They were not able to exchange gases with the surrounding air.  
 (4) They were not able to distribute food made to other parts of the plant.



- 13 Cayden conducted an experiment using 4 identical flowering plants. He covered a particular part of each plant with a plastic bag before placing them into a container of red-coloured water.

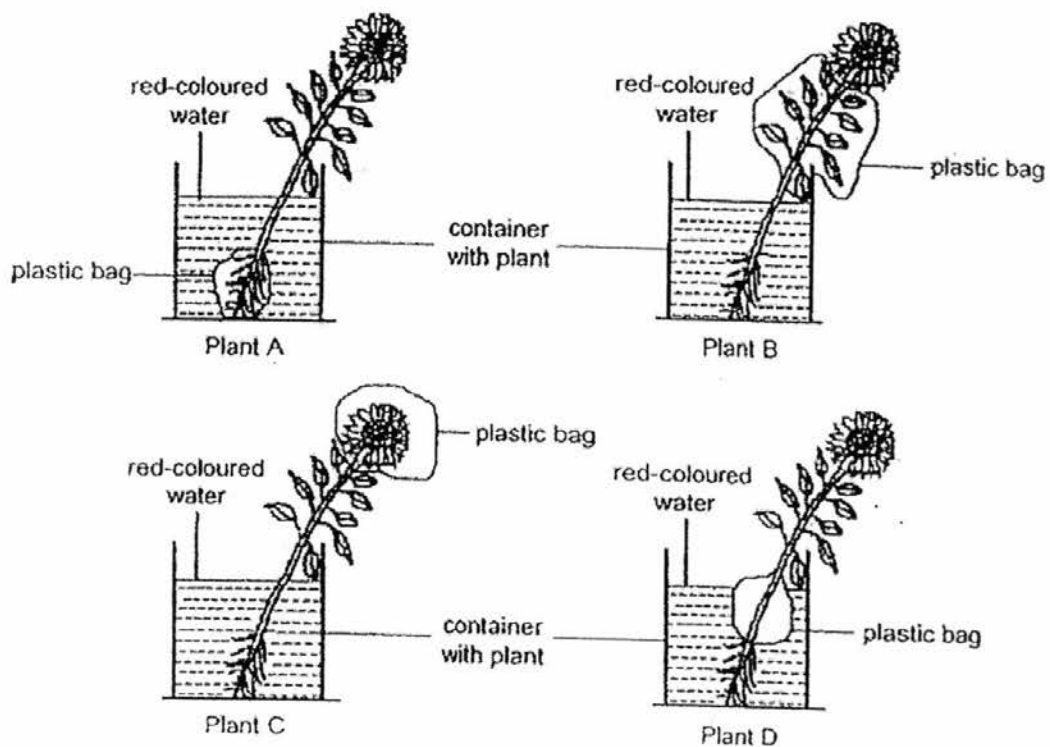

After 2 days, he noticed that more than 1 flower had red stains.

Which of the following plants most likely had red-stained flowers?

- (1) Plant A and D only
- (2) Plant B and C only
- (3) Plant A, B and D only
- (4) Plant B, C and D only

- 14 Ten people were trapped in an elevator for 20 minutes due to a power failure. The lights and ventilation fans in the elevator were not working as well. Which of the following correctly show the changes in the amount of gases in the elevator after 15 minutes?

	Amount of oxygen	Amount of carbon dioxide	Amount of water vapour
(1)	increases	decreases	increases
(2)	decreases	increases	increases
(3)	increases	decreases	decreases
(4)	decreases	increases	decreases

- 15 The diagram below shows the blood flow in blood vessels W, X, Y and Z in a human circulatory system.

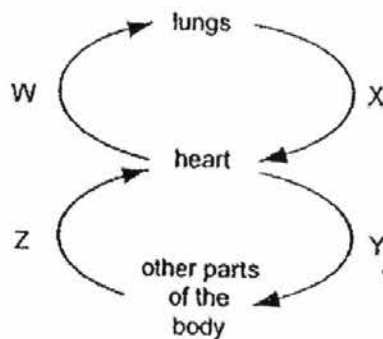

The graph below shows the composition of carbon dioxide for each of the blood sample taken from W, X, Y and Z.

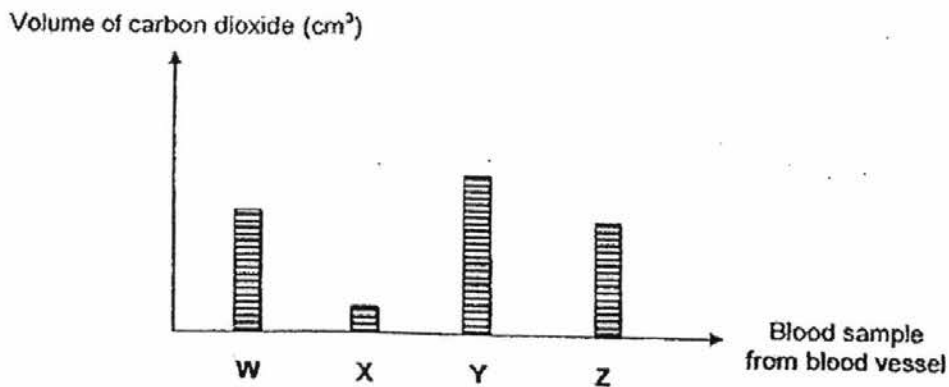

Which one of the bars shows the incorrect composition of carbon dioxide in the blood sample?

- (1) W  
 (2) X  
 (3) Y  
 (4) Z

- 16 Marcus listed some information about three different cells, P, Q and R.

Parts of a cell	Cell P	Cell Q	Cell R
Cell wall	No	Yes	Yes
Nucleus	Yes	Yes	Yes
Chloroplast	No	No	Yes

Based on the information given above, which of the following statements describe(s) cells P, Q and R correctly?

- A Cell P can be an animal cell.
- B Cell Q can possibly be taken from a root of a plant.
- C Cell R is able to make food for the plant.

- (1) B only
- (2) A and C only
- (3) B and C only
- (4) A, B and C

- 17 Tessa set up an electromagnet as shown below.

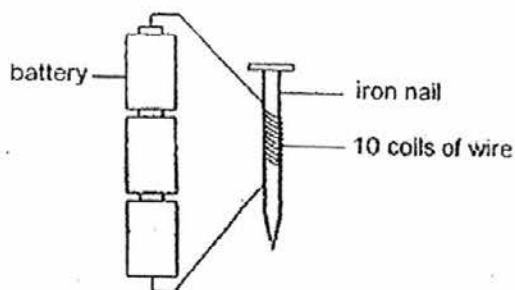

Which of the following can increase the strength of the electromagnet?

- A Using a longer iron nail.
- B Increasing the number of batteries used.
- C Using a nail made of silver instead of an iron nail.
- D Increasing the number of coils of wire around the iron nail.

- (1) A and C only
- (2) B and C only
- (3) B and D only
- (4) A and D only

18 Jayden set up an electrical circuit in an experiment to sound a buzzer. He tested if the buzzer rings with various combination with switches S1 and S2 opened, closed or opened and closed. His results are shown in the table below.

Switch S1	Switch S2	Does the buzzer ring?
opened	closed	Yes
closed	opened	No
opened	opened	No
closed	closed	Yes

Based on the results, which of the following circuits did Jayden use for the set-up?

(1)	
(2)	
(3)	
(4)	

- 19 A circuit diagram is shown below.

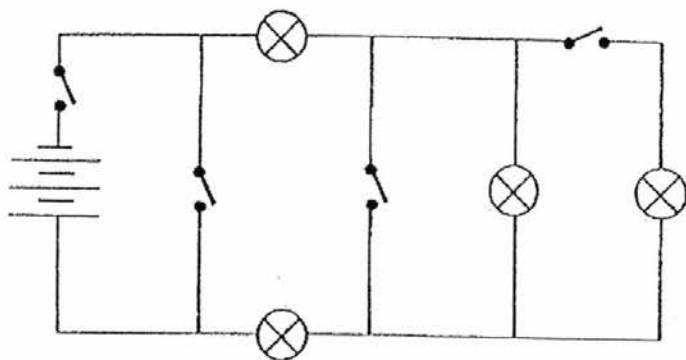

What is the least number of switches that have to be closed in order to have all the bulbs light up?

- (1) 1  
 (2) 2  
 (3) 3  
 (4) 4

- 20 Study the diagram below.

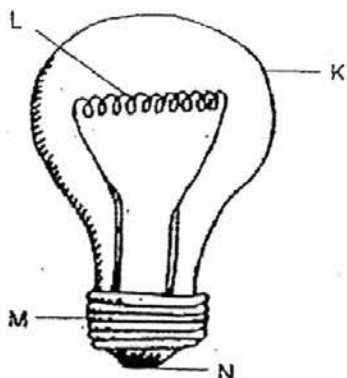

Which of the following statements are true about the light bulb?

- A Part L is usually made of tungsten.  
 B Part K is soft, flexible and transparent.  
 C Part M and N must be conductors of electricity.  
 D Part L gives off light and heat when there is electricity flowing through it.

- (1) A and D only  
 (2) B and C only  
 (3) A, C and D only  
 (4) A, B, C and D

21. The graph below shows the relationship between the number of batteries and the brightness of the light bulb in an electrical circuit.

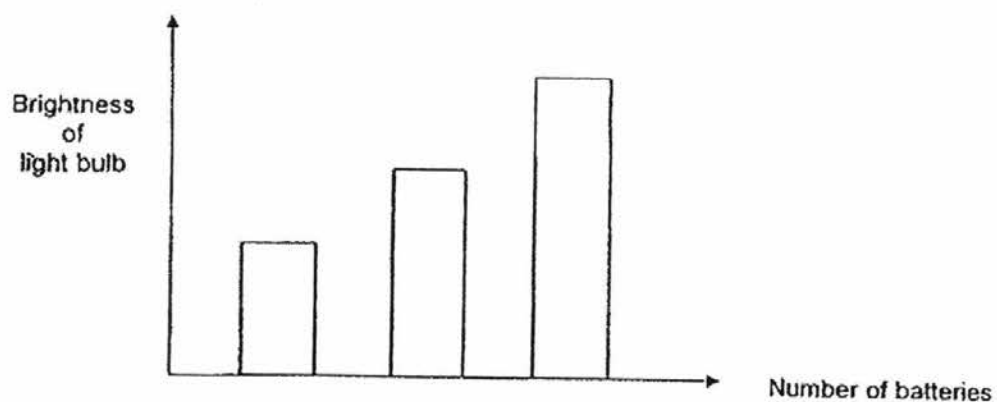

Which of the following statements correctly describes the graph above?

- (1) The number of batteries depends on the brightness of the light bulb.
  - (2) The brightness of the light bulb increases as the number of batteries increases.
  - (3) The number of batteries increases as the brightness of the light bulb decreases.
  - (4) The brightness of the light bulb decreases but the number of batteries increases.
- 22 Two different shadows, X and Y, were cast by an object when a light was shone on it from a different direction each time. The shadows are shown in the diagrams below.



X



Y

Which of the following objects could have cast the shadows, X and Y, as shown above?

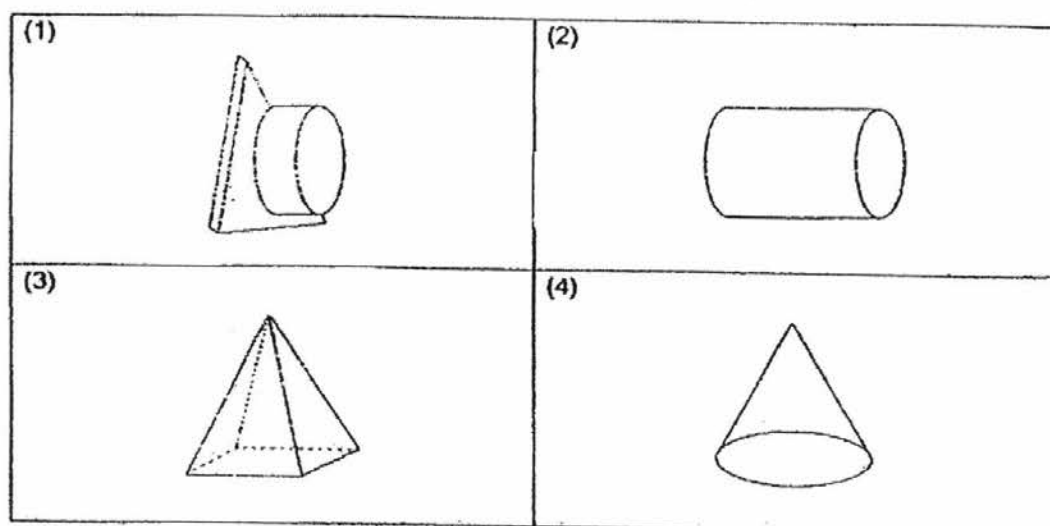

- 23 The diagram below shows a man walking down a street from Point Y to Point Z on a dark night. There were 4 street lamps along the street but only one street lamp was actually lighted up. The street lamps were the same distance apart from each other.

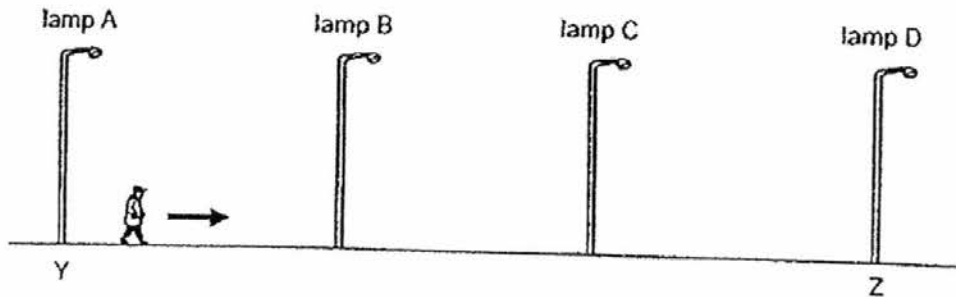

The graph below shows how the length of his shadow changes from Point Y to Point Z.

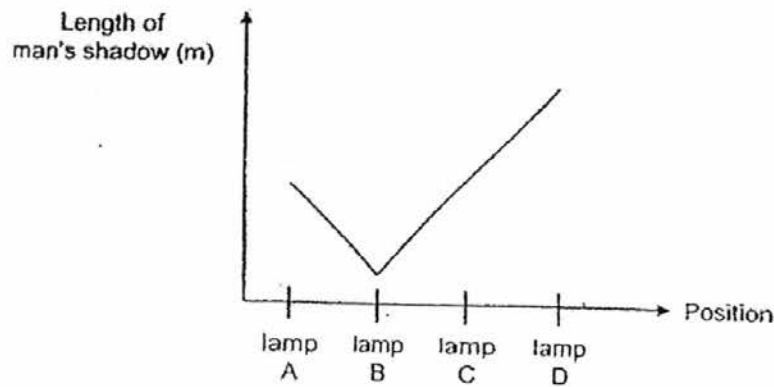

Based on the graph above, which of the street lamps, A, B, C, or D, was lighted up?

- (1) Lamp A
- (2) Lamp B
- (3) Lamp C
- (4) Lamp D

- 24 Four identical iron blocks were heated to a temperature of  $100^{\circ}\text{C}$ . Each block was then dropped into a beaker of water as shown in the diagram below. Each beaker contained a different amount of water, at a different temperature.

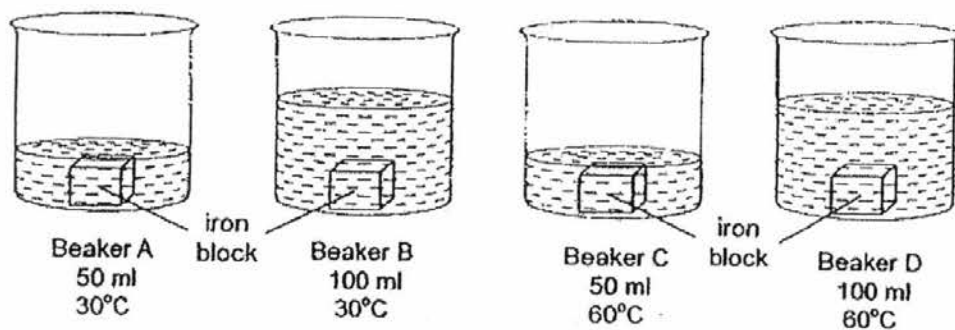

Which of the following correctly indicates the beakers with water at the highest and lowest temperature 1 minute after the blocks were dropped in?

	Water with Highest Temperature	Water with Lowest Temperature
(1)	Beaker A	Beaker D
(2)	Beaker B	Beaker C
(3)	Beaker C	Beaker B
(4)	Beaker D	Beaker A



- 25 When Sally went to the kitchen to get herself a glass of water, she found that glass A was stuck inside glass B, as shown in the diagram below.

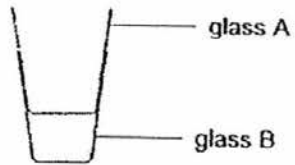

Which of the methods shown below would best enable her to separate glass A from glass B in the shortest time?

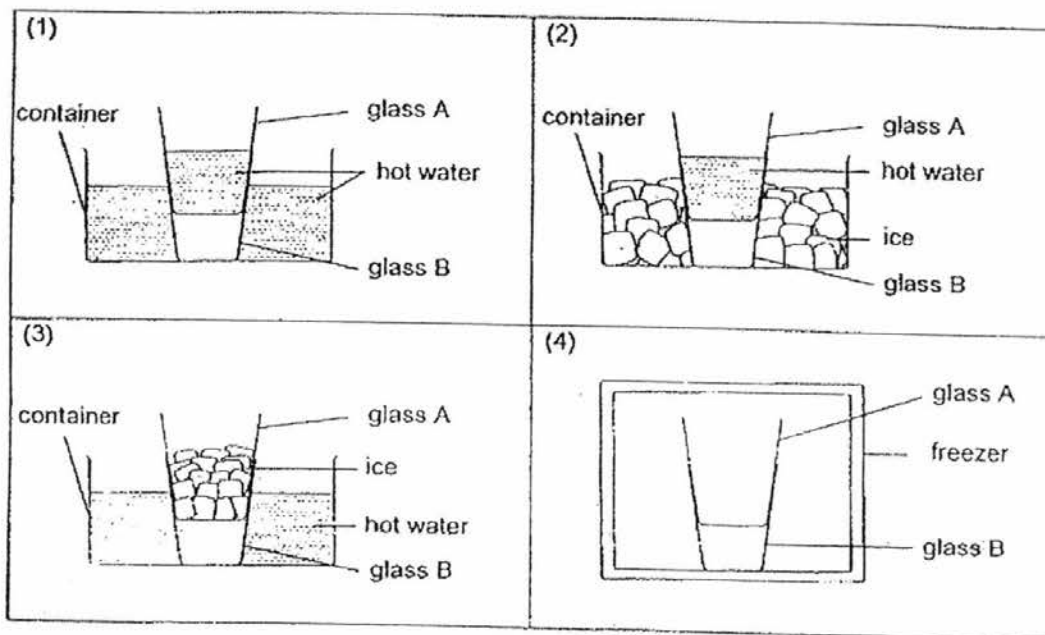

# Anglo-Chinese School (Junior)



## SEMESTRAL ASSESSMENT 1 (2016)

PRIMARY 5

SCIENCE

BOOKLET B

Tuesday

10 May 2016

1 hr 30 min

Name: \_\_\_\_\_ ( ) Class: 5.( ) Parent's Signature: \_\_\_\_\_

### INSTRUCTIONS TO PUPILS

- 1 Do not turn over the pages until you are told to do so.
- 2 Follow all instructions carefully.
- 3 There are 14 questions in this booklet.
- 4 Answer ALL questions.
- 5 The marks are given in the brackets [ ] at the end of each question or part question.

Booklet	Possible Marks	Marks Obtained
A	50	
B	40	
PBA	10	
Total	100	

---

This question paper consists of 17 printed pages (inclusive of cover page).

**Booklet B (40 marks)**

For questions 26 to 39, write your answers in this booklet.  
The number of marks awarded is shown in the brackets [ ] at the end of each question or part question.

- 26 The classification chart below shows how some animals can be grouped.

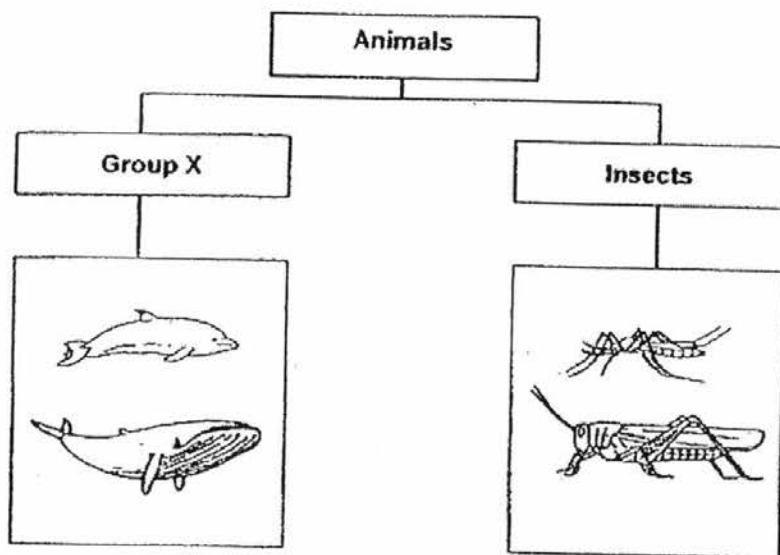

- (a) What is the correct heading for Group X? [1]

---

- (b) Besides laying eggs, what are 2 other characteristics of insects? [1]

---



---

(Go on to the next page)

SCORE	2
-------	---

- 27 The diagram below shows the life cycles of a frog and mosquito.

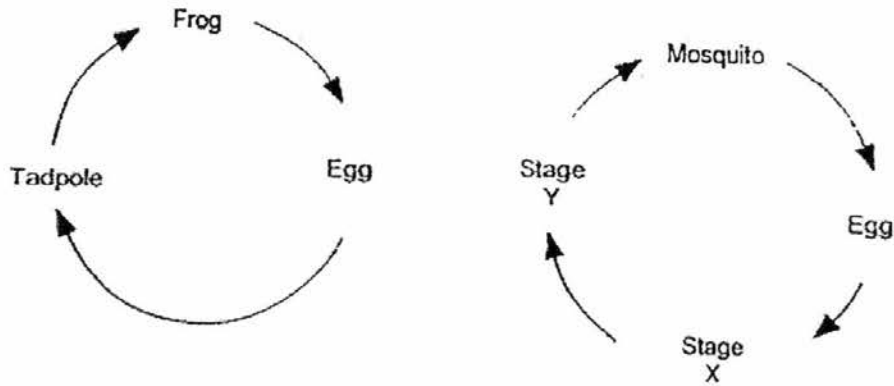

- (a) Based on the life cycles above, state one similarity and one difference between the life cycles of both animals. [1]

(i) Similarity :

---



---

(ii) Difference :

---



---

- (b) Name the stages X and Y in the life cycle of the mosquito. [1]

(i) X. \_\_\_\_\_ stage

(ii) Y: \_\_\_\_\_ stage

- (c) State 2 differences between stages X and Y in the life cycle of a mosquito. [1]

---



---

(Go on to the next page)

SCORE	
	3

- 28 The diagram below shows a glass cylinder containing  $200 \text{ cm}^3$  of air connected to a pump containing  $50 \text{ cm}^3$  of air. A valve prevents the air in the glass cylinder from flowing back into the pump.

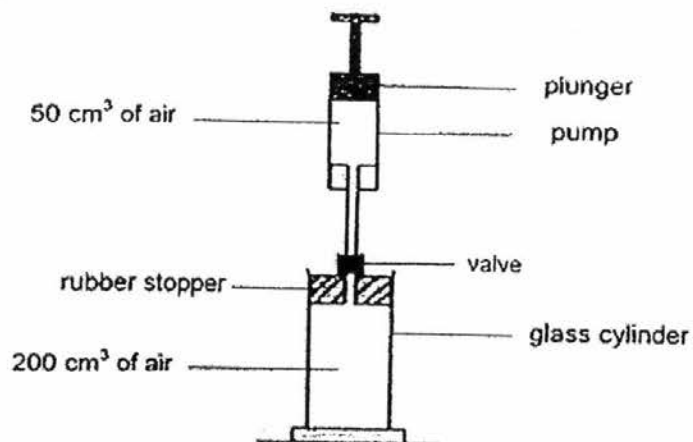

$50 \text{ cm}^3$  of air goes into the glass cylinder when the plunger is pushed all the way into the pump. The plunger is pushed all the way once.

- (a)(i) What is the volume of air in the glass cylinder? Explain why. [1]

---



---

- (ii) Has the mass of air in the glass cylinder decreased, increased or remained the same? Explain your answer based on the property of matter. [1]

---



---

(Go on to the next page)

SCORE	2
-------	---

In another set-up, a glass cylinder containing  $200\text{ cm}^3$  of air is connected to a pump containing  $50\text{ cm}^3$  of water. A valve prevents the air in the glass cylinder from flowing back into the pump.

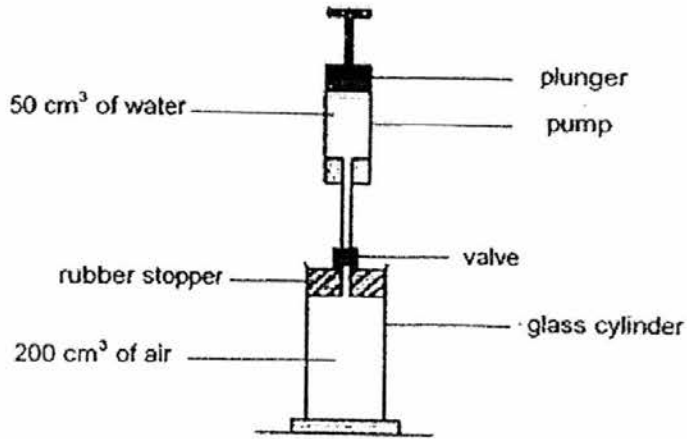

$50\text{ cm}^3$  of water goes into the glass cylinder every time the plunger is pushed all the way into the pump.

What would the volume of air in the glass cylinder be after the plunger is pushed in all the way? Explain why. [1]

---



---

(Go on to the next page)

SCORE	1
-------	---

- 29 Jack placed object X on a wooden toy boat floating on a plastic basin of water as shown in the diagram below.

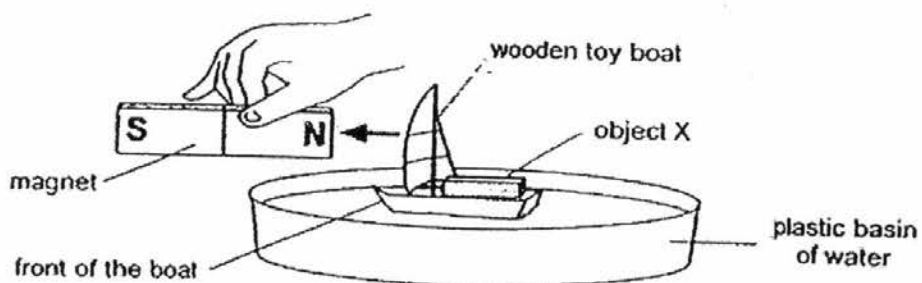

When Jack brought the N-pole of a magnet close to the front of the wooden toy boat, the wooden toy boat moved towards the magnet.

- (a) Why did the wooden toy boat move towards the magnet? Explain your answer. [1]

---



---

When Jack brought the S-pole of the magnet close to the front of the wooden toy boat, the wooden toy boat moved away from the magnet.

- (b) Based on Jack's observation above, what can Jack conclude about object X? Explain why. [1]

---



---

- (c) When Jack brings the N-pole of the magnet close to the front of the wooden toy boat, will the wooden toy boat move towards the magnet if object X is made of copper? Explain your answer. [1]

---



---

(Go on to the next page)

SCORE	3
-------	---

- 30 The pulling distance of a magnet is the greatest distance from which a magnet is able to attract an object made of a magnetic material. Tom carried out an experiment to find the pulling distance of 3 magnets, X, Y and Z, using the set-up as shown in the diagram below.

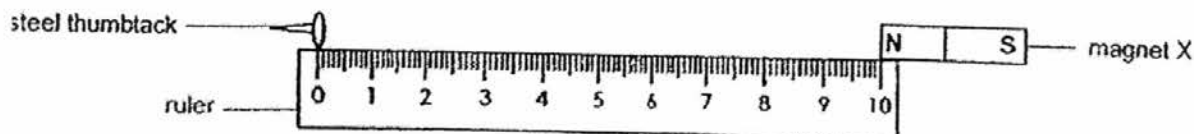

Tom placed magnet X at the 10 cm mark of the ruler and a steel thumbtack at the 0 cm mark of the ruler. He then slowly pushed magnet X towards the thumbtack, stopping immediately when the thumbtack was attracted by magnet X and recorded the pulling distance of the magnet. He repeated the experiment using magnets Y and Z.

The results of his experiment are shown in the table below.

Magnet	Pulling Distance (cm)
X	1.5
Y	4
Z	2.5

- (a) List the magnets, X, Y and Z according to their magnetic strength, from strongest to weakest. [1]

\_\_\_\_\_

- (b) State the relationship between the magnetic strength of a magnet and the pulling distance of a magnet. [1]

\_\_\_\_\_

\_\_\_\_\_

Tom placed magnet X on a piece of paper, before sprinkling iron filings over magnet X and the piece of paper. The diagram below shows the pattern formed by the iron filings.

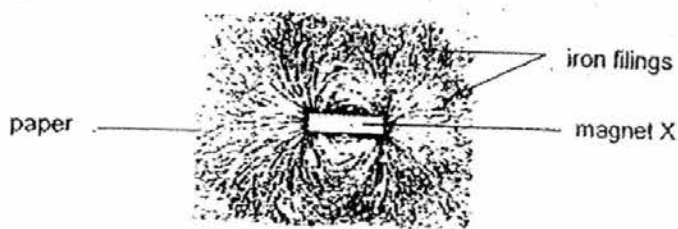

- (c) Tom observed that there were more iron filings at the two ends of the magnet. What can Tom infer from this observation? [1]

\_\_\_\_\_

\_\_\_\_\_

(Go on to the next page)

SCORE	
	3



31 Study the diagram of the human digestive system below.

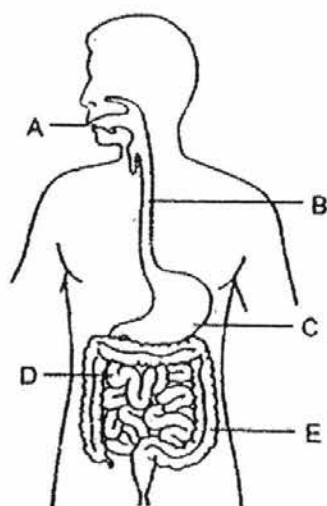

- (a) State the function of part E of the digestive system. [1]

---



---

- (b) The bar graphs below show the amount of digested food in the contents taken from part B and part C. Draw another 2 bar graphs to show the most likely amount of digested food in part A and part D. [1]

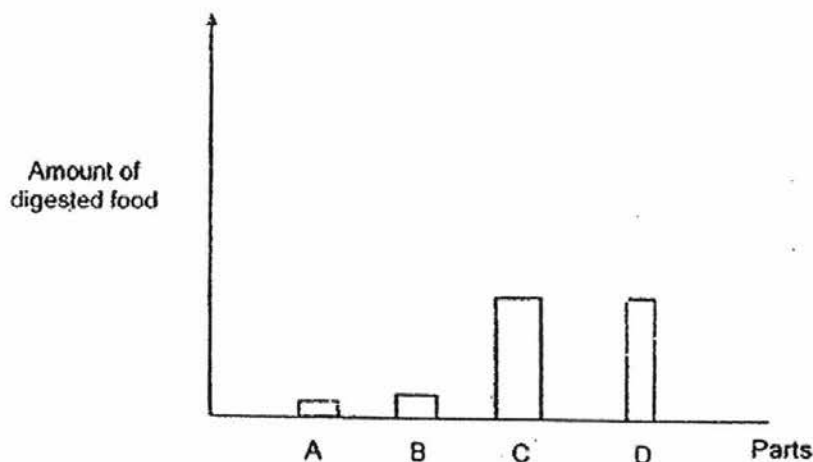

(Go on to the next page)

SCORE	2
-------	---

- 32 Christopher placed a balsam plant in a beaker with 600ml of water that had been mixed with blue-coloured food dye. The next day he cut a cross-section of the stem.

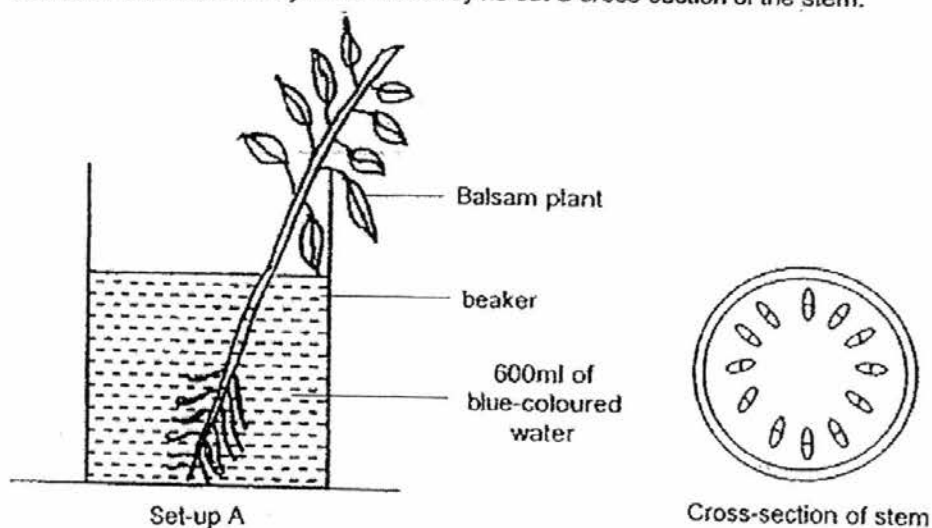

Christopher noticed that there were blue stains on some parts of the cross-section of stem.

- (a) Which part of the plant structure in the cross-section of stem was stained blue? [1]

\_\_\_\_\_

- (b) Explain how it is possible for the part mentioned in (a) to be stained blue. [1]

\_\_\_\_\_

\_\_\_\_\_

Christopher wanted to carry out an experiment to find out if the number of leaves of a balsam plant affects the amount of water taken in by the plant using set-ups A and B.

- (c) Draw and label Set-up B in the box below to carry out a fair test. [1]

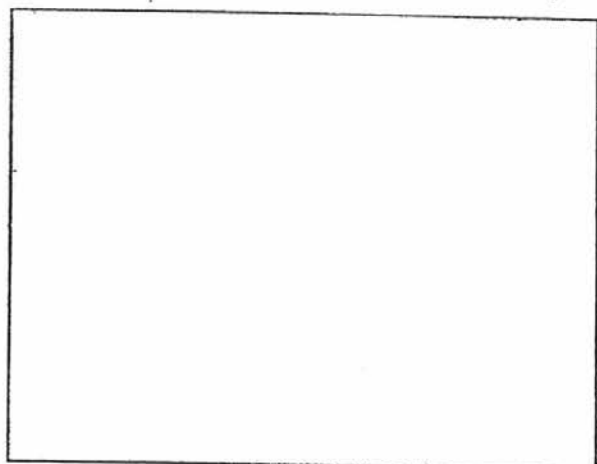

(Go on to the next page)

SCORE	
	3

- 33 Daniel made the following model of the human respiratory system. The balloon in the jar will expand when the stretched rubber sheet at the bottom of the bell jar is pulled downwards.

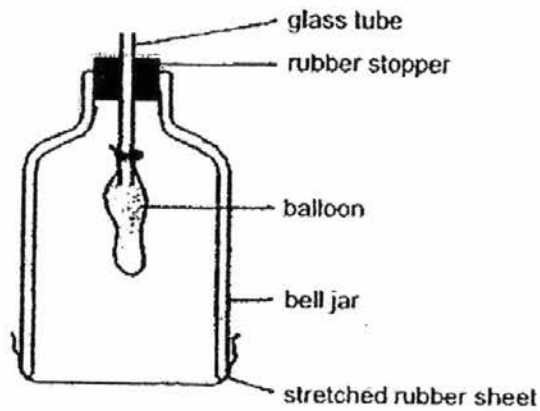

Complete the table below to show what each part of the model represents in the human body system. [2]

Model	Part of the Human Body System	Function
bell jar		
balloon		

(Go on to the next page)

SCORE	2
-------	---

- 34 The diagram below shows how the respiratory, circulatory and digestive systems in our body work together. The arrows represent the movement of the blood.

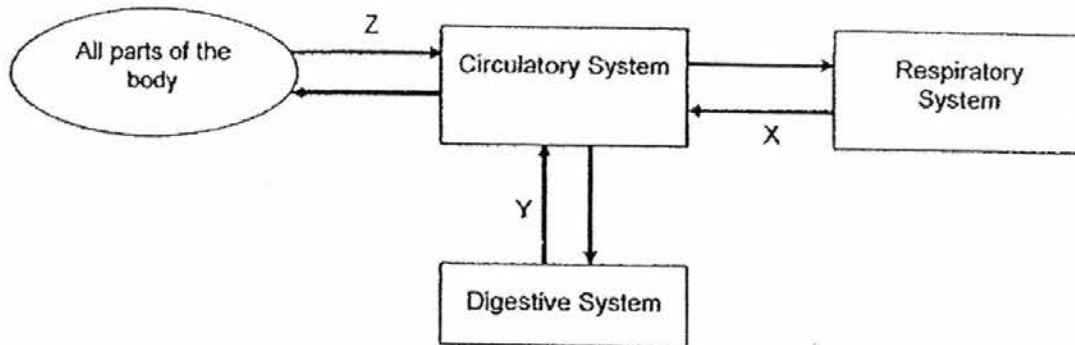

- (a) Name a substance that is greater in amount in the blood at Y than the blood at X. [1]

---

- (b) Give a reason why the substance in (a) is greater in amount in the blood at Y than the blood at X. [1]

---



---

- (c) State a difference between the blood at Z and blood at X. [1]

---



---

(Go on to the next page)

SCORE	3
-------	---

- 35 The diagram below shows two plant cells, A and B, as seen under a microscope.

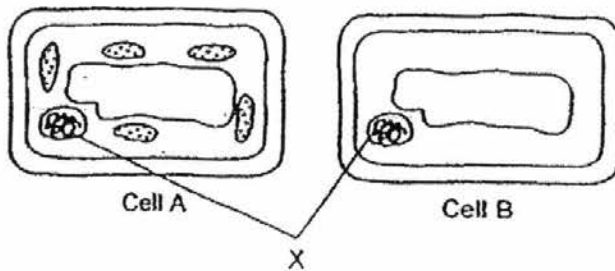

- (a) State the difference between Cell A and Cell B. [1]

---

- (b) Name the part labeled X and its function. [1]

---



---

- (c) Which part of the plant is Cell B most likely from? Explain your answer. [1]

---



---

(Go on to the next page)

SCORE	
	3

- 36 Gabriel used a circuit tester to test a circuit card. He connected the points X and Y of the circuit tester to the metal pins A, B, C, D and E on the circuit card to see if the bulb would light up.

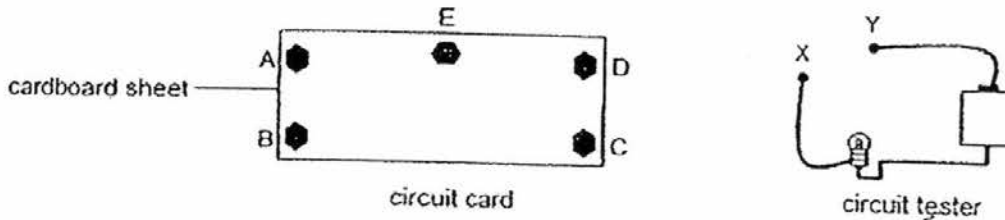

He recorded the results of the connection in the table below.

Metal pins connected		Did the bulb light up?
A	D	No
A	C	No
C	B	Yes
E	B	Yes
E	C	Yes
E	D	Yes

- (a) Based on the results, draw lines(s) on the circuit card below to show how the metal pins are connected. [1]

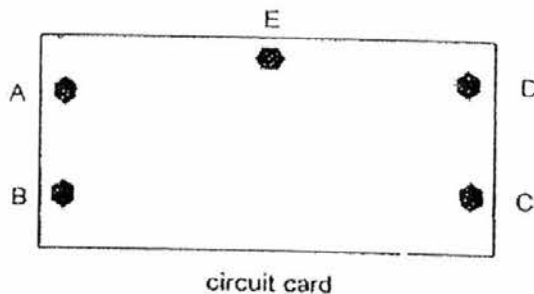

Gabriel changed the cardboard sheet to an aluminium sheet.

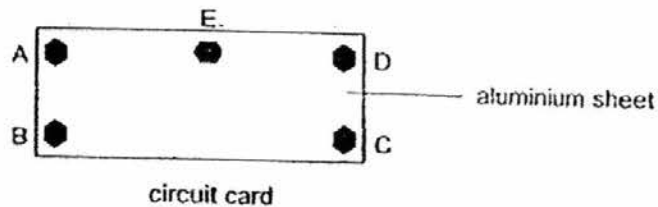

- (b) He then showed the circuit card to his friend. His friend told him that the circuit card will not be able to produce the same results as shown in the table above. Explain why. [1]

(Go on to the next page)

SCORE	2
-------	---

- 37 Benjamin set up a circuit as shown below.

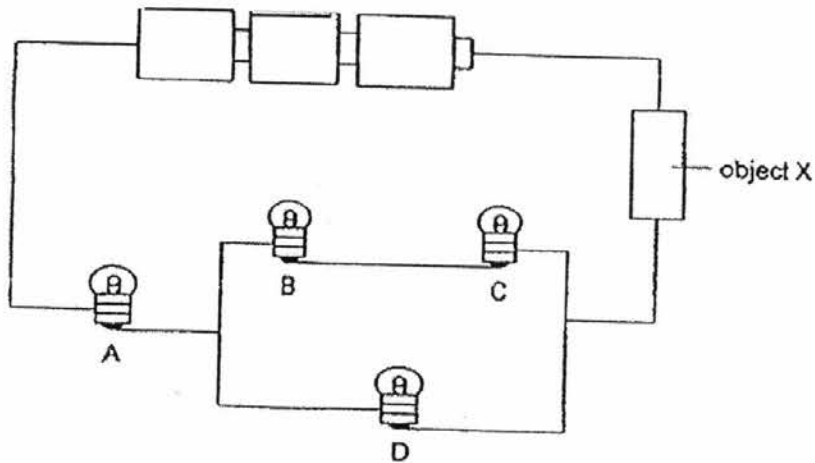

- (a) He observed that the bulbs light up when he connected object X to the circuit. What is object X most likely made of? State a property of object X that allows him to make this observation. [1]

---



---

- (b) Complete the table below to show what happens if one of the bulbs in the circuit fuses. [2]

Bulb that fused	Bulb(s) that will remain light up
A	
B	
C	
D	

- (c) Benjamin's teacher said that it is better to connect the light in the classroom in a parallel arrangement. Explain why. [1]

---



---

(Go on to the next page)

SCORE	4
-------	---

Benjamin wanted to add some switches so that he is able to switch on all the 4 bulbs or only 3 bulbs.

- (d) Draw a circuit diagram and show where the switches can be placed in the circuit. [1]

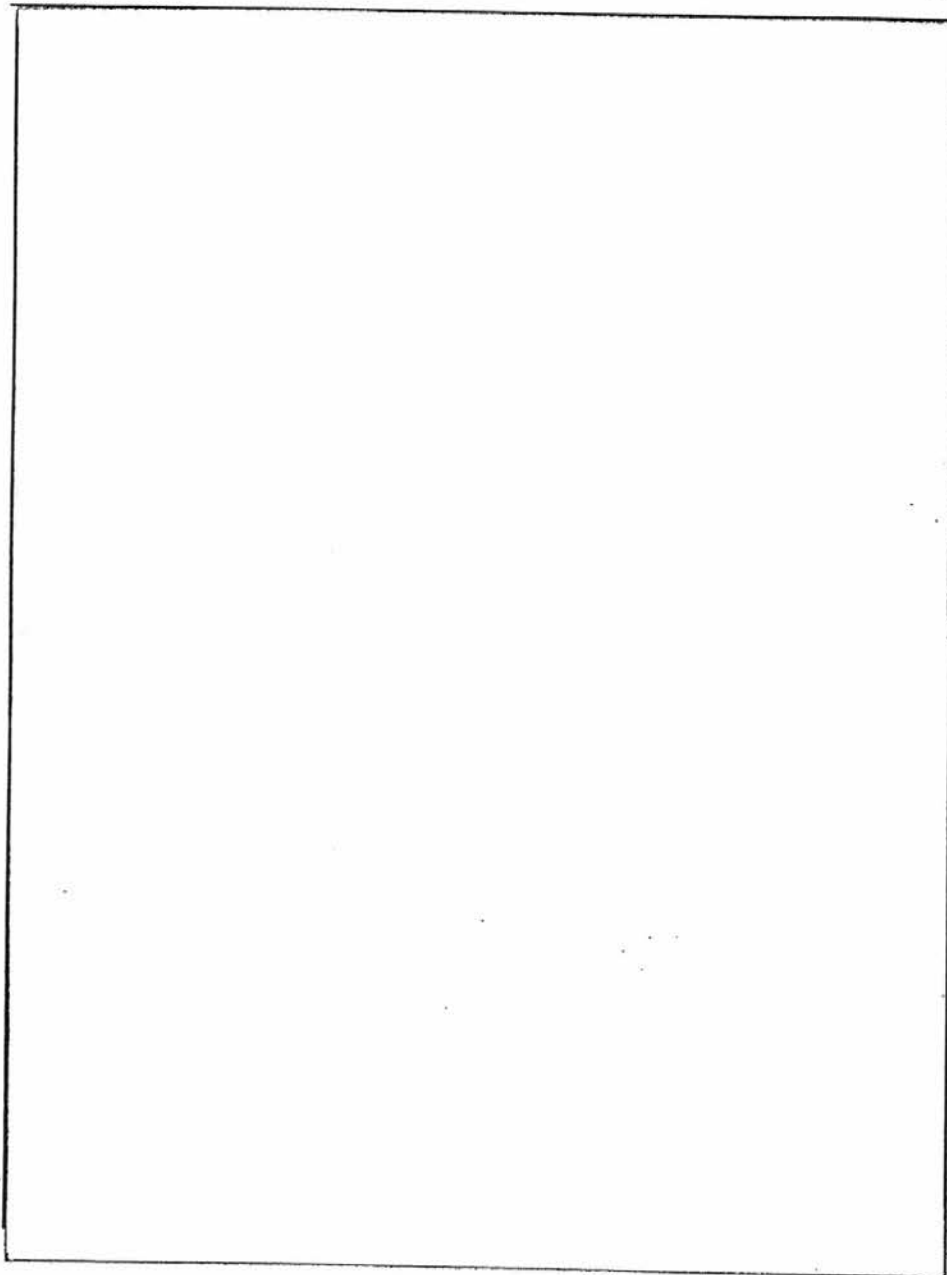

(Go on to the next page)

SCORE	1
-------	---



- 38 Henry made a simple periscope using a cardboard box and two small mirrors as shown in the diagram below.

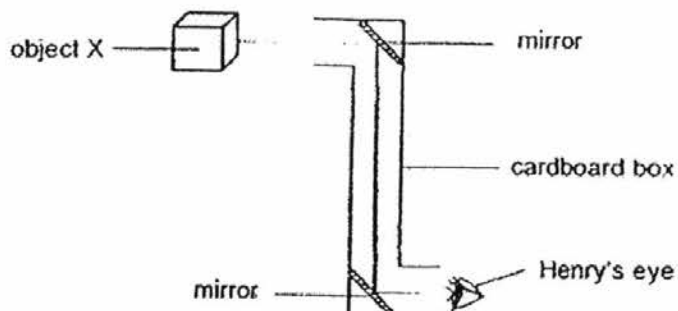

- (a) Using the periscope, Henry is able to see object X. Draw an arrow (  $\rightarrow$  ) in the diagram above to represent the path of light that enables Henry to see object X. [1]
- (b) State two properties of light that allow Henry's periscope to work. [1]
- \_\_\_\_\_
- \_\_\_\_\_
- (c) Henry's classmate, Linda, told him that light is matter. Is Linda correct? Give two reasons to support your answer. [1]
- \_\_\_\_\_
- \_\_\_\_\_

(Go on to the next page)

SCORE	
	3

- 39 The diagram below shows an iron bar Z at room temperature. An ice cube is placed at point J on the iron bar Z. A temperature sensor connected to a data-logger was used to measure the temperature of the iron bar Z at point K.

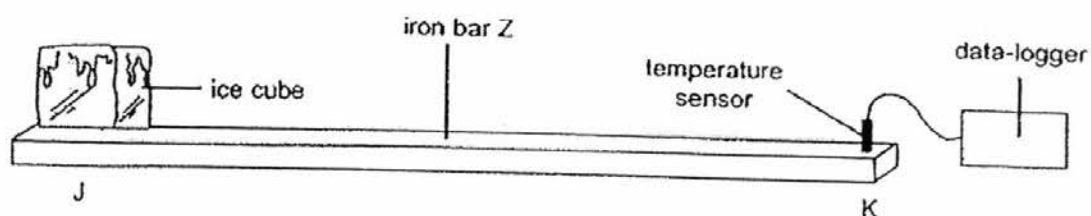

- (a) After 5 minutes, it was observed that the temperature of the iron bar Z at point K dropped from room temperature to  $5^{\circ}\text{C}$ . Explain clearly how this happened. [1]
- 
- 
- (b) After one hour, the temperature of the iron bar Z gradually returned to room temperature. Explain clearly why this happened to the iron bar Z. [1]
- 
- 
- (c) The experiment was repeated using bars P, Q and R that are identical to iron bar Z but made of different materials. The temperature of the bars was at room temperature at the start of the experiment. The results of the temperature of the bar after 5 minutes at point K are recorded in the table below.

Bar	Temperature of Bar after 5 min ( $^{\circ}\text{C}$ )
P	5
Q	24
R	22

What is the aim of the experiment?

[1]

End of paper

SCORE	3
-------	---

SEMESTRAL ASSESSMENT EXAM PAPER 2016

SCHOOL : ANGLO-CHINESE SCHOOL (JUNIOR)  
SUBJECT : SCIENCE  
TERM : SA1

BOOKLET A

Q1	Q2	Q3	Q4	Q5	Q6	Q7
4	3	4	4	3	1	4
Q8	Q9	Q10	Q11	Q12	Q13	Q14
1	2	3	3	3	4	2
Q15	Q16	Q17	Q18	Q19	Q20	Q21
3	4	3	3	2	3	2
Q22	Q23	Q24	Q25			
4	2	3	3			

26. (a) The correct heading for Group X is mammals.

BOOKLET B

(b) Besides laying eggs, insects also have six legs and three body parts.

27(a)(i) Both lay many eggs at a time.

(ii) The life cycle of a mosquito has four stages while the frog has three.

(b)(i) X: Larva stage

(i) Y: Pupa stage

(c) In stage Y the mosquito does not move but in stage X it moves. In stage X mosquito eats unlike in stage Y.

Q28(a)(i) The volume of the air in the glass cylinder is 200cm<sup>3</sup>. Although more air is being pumped into the glass cylinder, the air can compress for more air to enter.

(ii) The mass of the glass cylinder increased. As more air is pumped into the glass cylinder, the mass increases because all matter has mass.

(b) Air can be compressed but matter cannot be compressed and has taken up the space.

Q29(a) The magnet was attracting object X that was placed on the wooden toy boat as it is made of a magnetic material.

(b) Jack can conclude that object X is a magnet. Only magnets can be repelled by other magnets.

(c) The wooden toy boat will not move towards the magnet. As copper is not a magnetic material, the magnet would not attract it.

Q30(a) Magnets Y, Z and X.

(b) The more magnetic strength has, the further away the magnetic materials can be for the magnet to attract it.

(c) The magnet strength is strongest at its ends.

Q31(a) Part E absorbs water from undigested food.

(b)

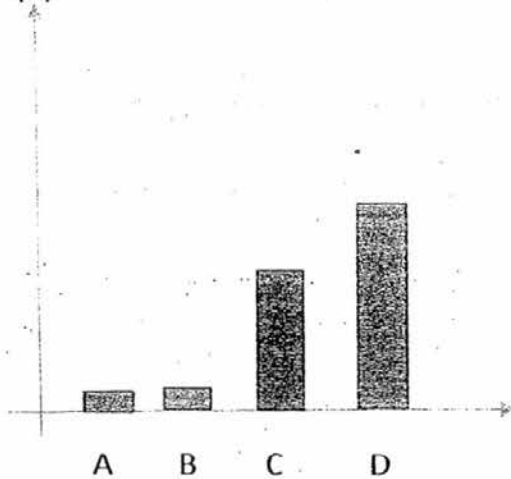

Q32(a) The water carrying tubes of the stem was stained blue.

(b) The roots absorb the blue-coloured water and transports it through the water-carrying tubes.

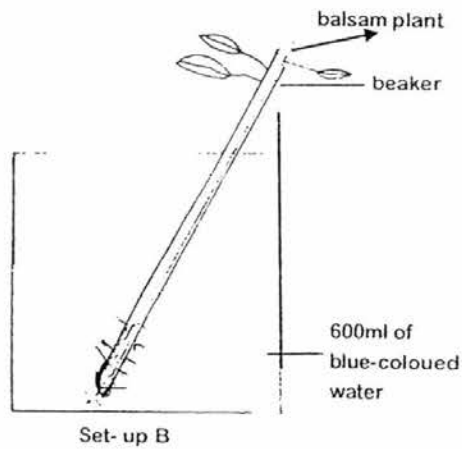

(c)

Q33.

Model	Part of the human body system	Function
Bell Jar	Ribcage	Protects the heart and other organs and gives the body its shape.
Balloon	Lungs	Allows the exchange of gases to take place.

Q34(a) There is more digested food in the blood at Y than the blood at X.

(b) The blood transports the digested food from the digestive system to all parts of the body before reaching the respiratory system and there will be less food compared to the blood at Y.

(c) The blood at X has more oxygen compared to the blood at Z.

Q35(a) Cell A has chloroplast but cell B does not have chloroplast.

(b) The part labelled X is the nucleus. The nucleus controls all the activities in the cell and passes information from generation to generation.

(c) Cell B is likely to be from the roots. The cells in the roots have no chloroplast as it is not needed to make food.

Q36(a)

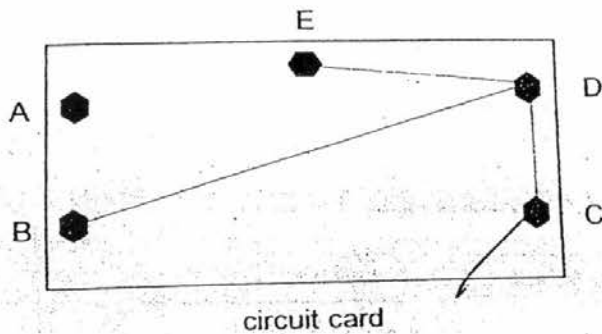

(b) As aluminium is a conductor of electricity, no matter which pin you connect the bulb will still light up.

Q37(a) Object X is most likely made of a magnetic material such as iron. Object X must be able to conduct electricity.

(b) A- None

B- A and D

C- A and D

D- A, B and C

(c) If one bulb fuses in a parallel circuit, the other bulbs will still light up. However if they are connected in a series circuit when one bulb fuses none of the bulbs will light up.

(d)

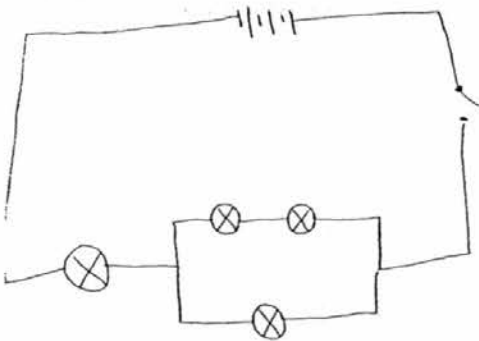

Q38(a)

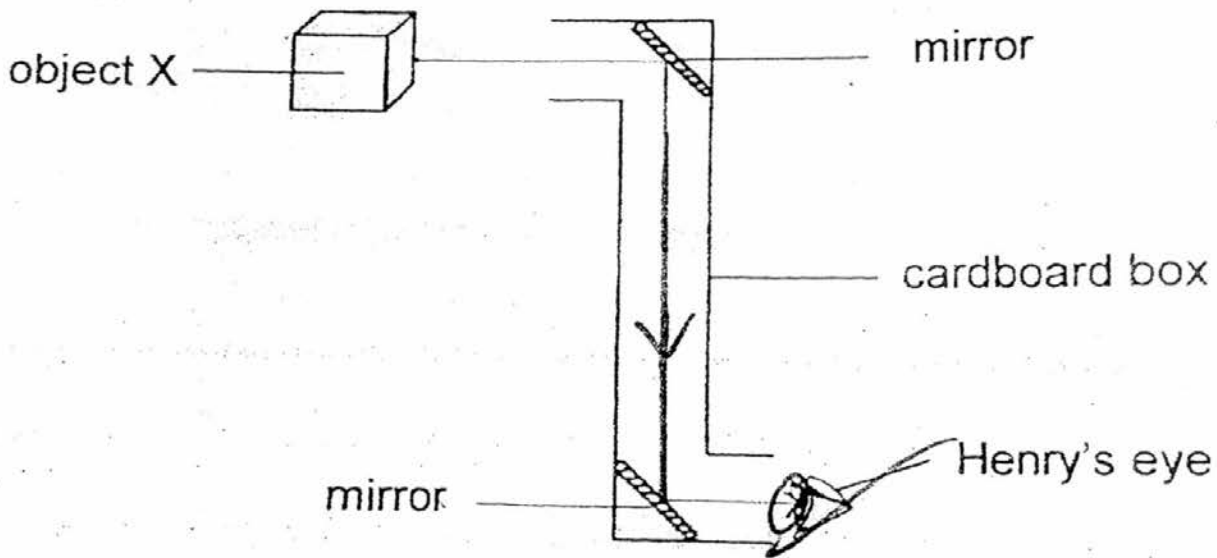

(b) Light must travel in straight lines and must be able to be reflected by mirrors for the periscope to work.

(c) Linda is wrong. As light has neither mass nor volume, light is not matter.

Q39(a) Iron bar Z lost heat to the ice cube as iron bar is a good conductor of heat. Hence, the temperature dropped to  $5^{\circ}\text{C}$ .

(b) The ice cube melted and iron bar Z gained heat from the surroundings.

(c) To find out which are good conductors of heat.

5  
END.

