

METHODIST GIRLS' SCHOOL (PRIMARY)  
CONTINUAL ASSESSMENT 1  
SCIENCE – PRIMARY FIVE  
2010

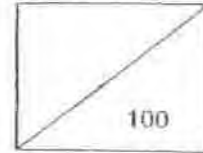

NAME : \_\_\_\_\_ ( )

DATE: 2<sup>nd</sup> March 2010

CLASS : \_\_\_\_\_

SECTION A (60 MARKS)

For each question from 1 to 30, four options are given. One of them is the correct answer. Make your choice (1, 2, 3 or 4). Shade the correct oval (1, 2, 3 or 4) on the Optical Answer Sheet.

1. Study the classification chart below. Identify A, B, C and D.

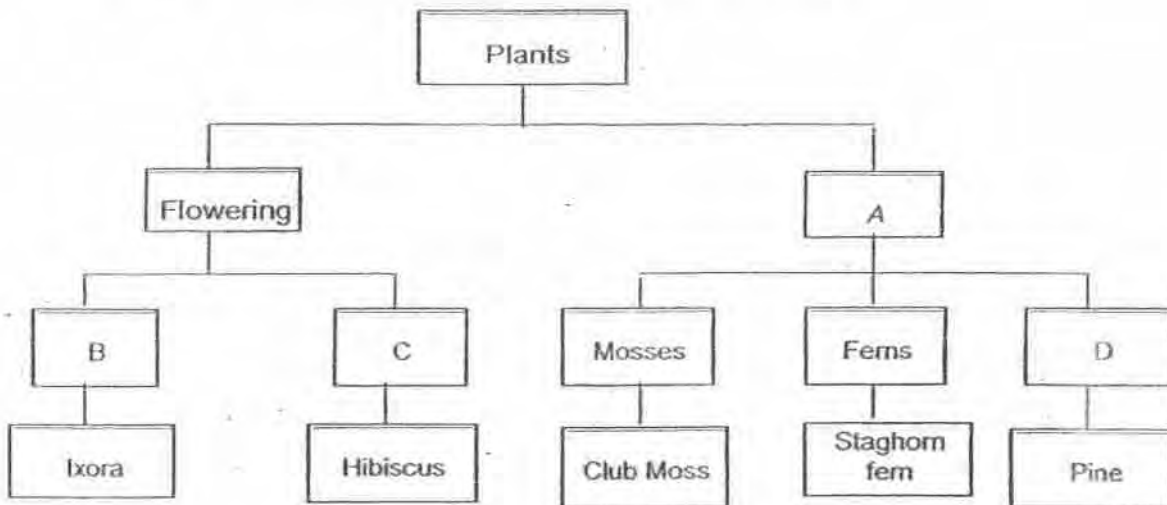

What do A, B, C and D represent?

	A	B	C	D
(1)	Reproduced by spores	Brightly coloured flowers	Dull coloured flowers	Conifers
(2)	Reproduced by spores	Tiny flowers	Big flowers	Algae
(3)	Non-flowering	Flowers grow singly	Flowers grow in clusters	Algae
(4)	Non-flowering	Flowers grow in clusters	Flowers grow singly	Conifers

12.

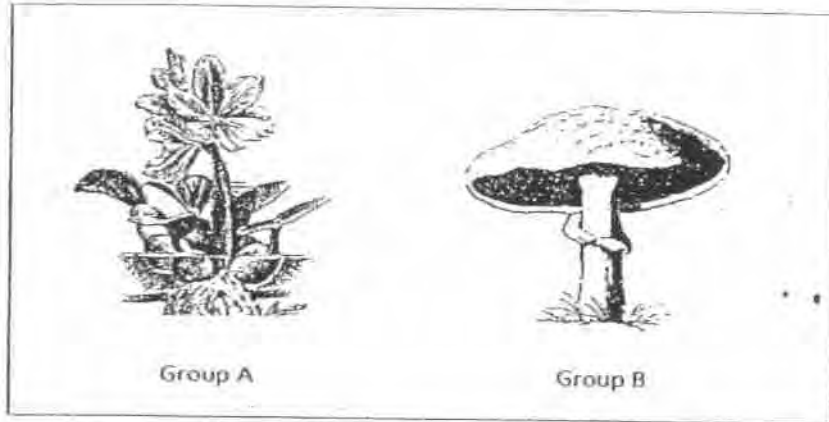

Mel was told to group the following organisms according to how they were similar to those above.



1

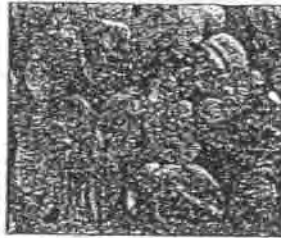

2

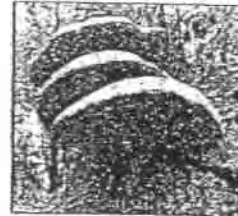

3

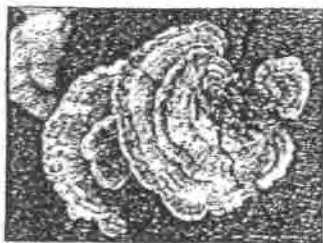

4



5



6

Which of the following shows correctly how she has grouped them?

	Group A	Group B
(1)	2, 3, 5, 6	1, 4
(2)	2, 5, 6	1, 3, 4
(3)	5, 6	1, 2, 3, 4
(4)	2, 4, 5, 6	1, 3

3. Study the classification table below:

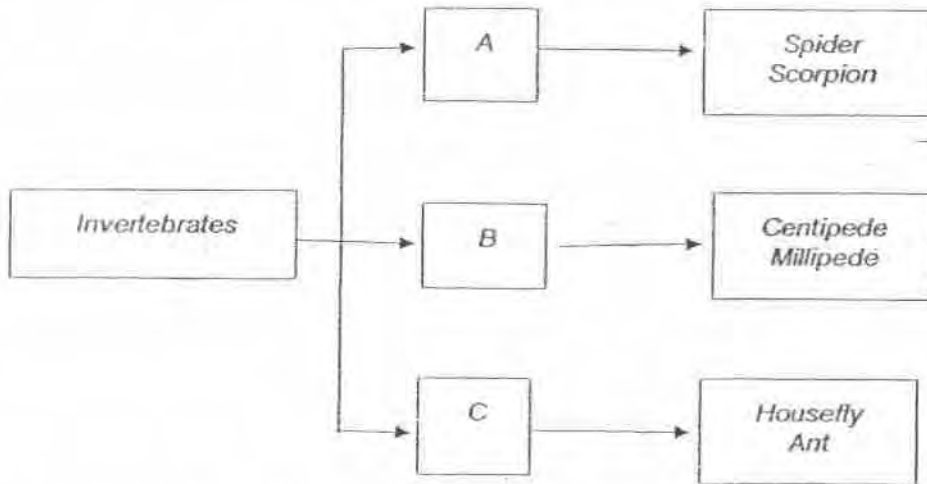

What suitable sub-headings could A, B and C represent?

	A	B	C
(1)	Can fly	Can crawl	Can swim
(2)	4 pairs of legs	More than 4 pairs of legs	3 pairs of legs
(3)	No segmented bodies	Many segmented bodies	3 segmented bodies
(4)	Has exoskeleton	No exoskeleton	Has exoskeleton

4. The diagram shows three groups of animals.

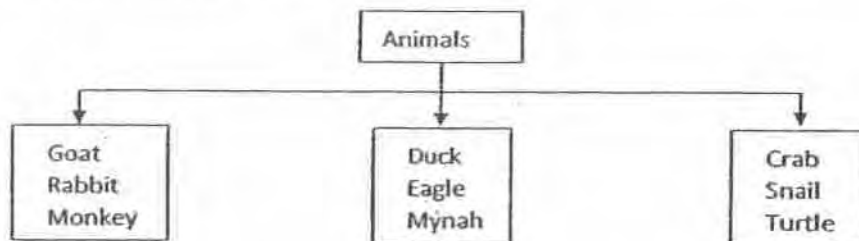

These animals are classified according to \_\_\_\_\_.

- (1) their eating habits
- (2) their body coverings
- (3) the way they move
- (4) their breathing parts

5. Look at the fruits below.

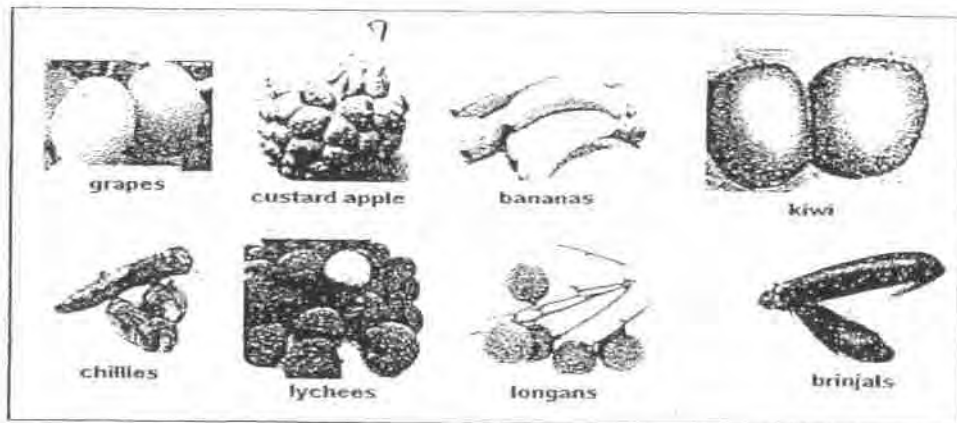

We can classify the fruits above based on their \_\_\_\_\_

- A : shape
- B : edibility
- C : skin texture
- D : number of seeds

- (1) A and B only
- (2) B and C only
- (3) A, C and D only
- (4) A, B, C and D

6. The life cycles of two insects are shown below.

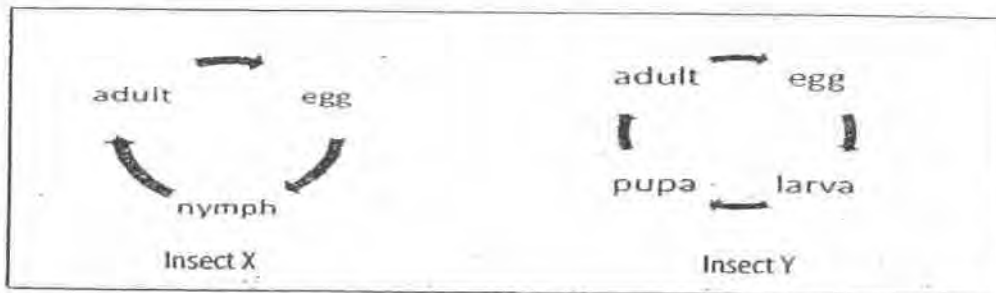

What conclusions can you make from the information provided?

- A : Both insects hatch from eggs.
- B : Insect X is a carnivore but Insect Y is a herbivore.
- C : The two insects undergo different stages in their life cycles.
- D : The young of the Insect Y resemble the adult in many ways.

- (1) A and C only
- (2) B and D only
- (3) A, C and D only
- (4) A, B, C and D

7. Jean wanted to find out what type of soil was most suitable for growing balsam plants. She planted 3 balsam plants in three pots, X, Y and Z.

	Pot X	Pot Y	Pot Z
Material of pot	Plastic	Plastic	Plastic
Type of soil	Garden soil	Sand	Clay
Amount of soil in pot	1500 cm <sup>3</sup>	1000 cm <sup>3</sup>	500 cm <sup>3</sup>
Amount of water used every day	200 cm <sup>3</sup>	220 cm <sup>3</sup>	210 cm <sup>3</sup>

The three plants were initially placed in the same location in the garden as shown in the diagram below.

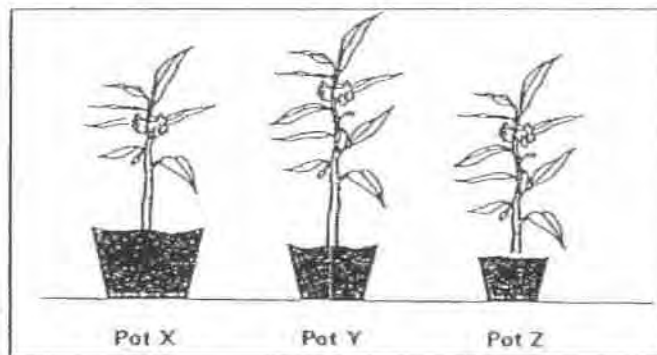

Why was the experiment **NOT** a fair one?

- A : The plant is not of the same size
- B : The amount of soil in each pot was different.
- C : The type of soil used in each pot was different.
- D : The amount of water given to the three pots was different.

- (1) A and B only
- (2) A and C only
- (3) A, B and C only
- (4) A, B and D only

8. The diagram below shows the flow of substances in our lungs during the respiration process.

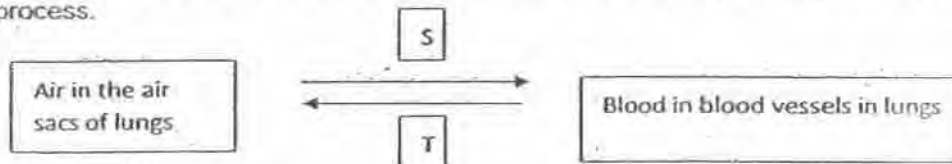

What are substances S and T likely to be?

	S	T
(1)	Carbon dioxide	Oxygen + water vapour
(2)	Carbon dioxide	Water vapour + glucose
(3)	Oxygen	Carbon dioxide + water vapour
(4)	Oxygen	Glucose + carbon dioxide

9. The diagram below shows the life cycle of a plant.

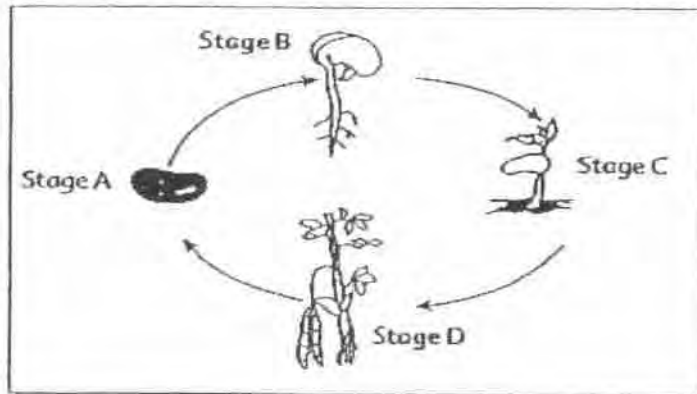

Which of the following statements are true?

- A : Sunlight is needed at stage B.
- B : Photosynthesis takes place at stages C and D.
- C : Stage A is not affected by what happens at stage D.
- D : The seed at stage A needs air, water and warmth to reach stage B.

- (1) A and C only
- (2) B and D only
- (3) A, B and C
- (4) A, B, C and D

10. Look at the group of animals below.

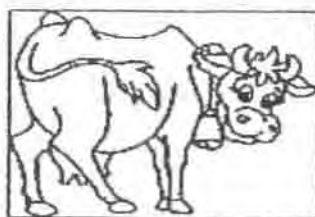

In what way are the animals similar?

- (1) All of them have legs.
- (2) All of them produce milk.
- (3) All of them lay eggs.
- (4) All of them are plant – eaters.

11. The diagrams below show some systems in our bodies.

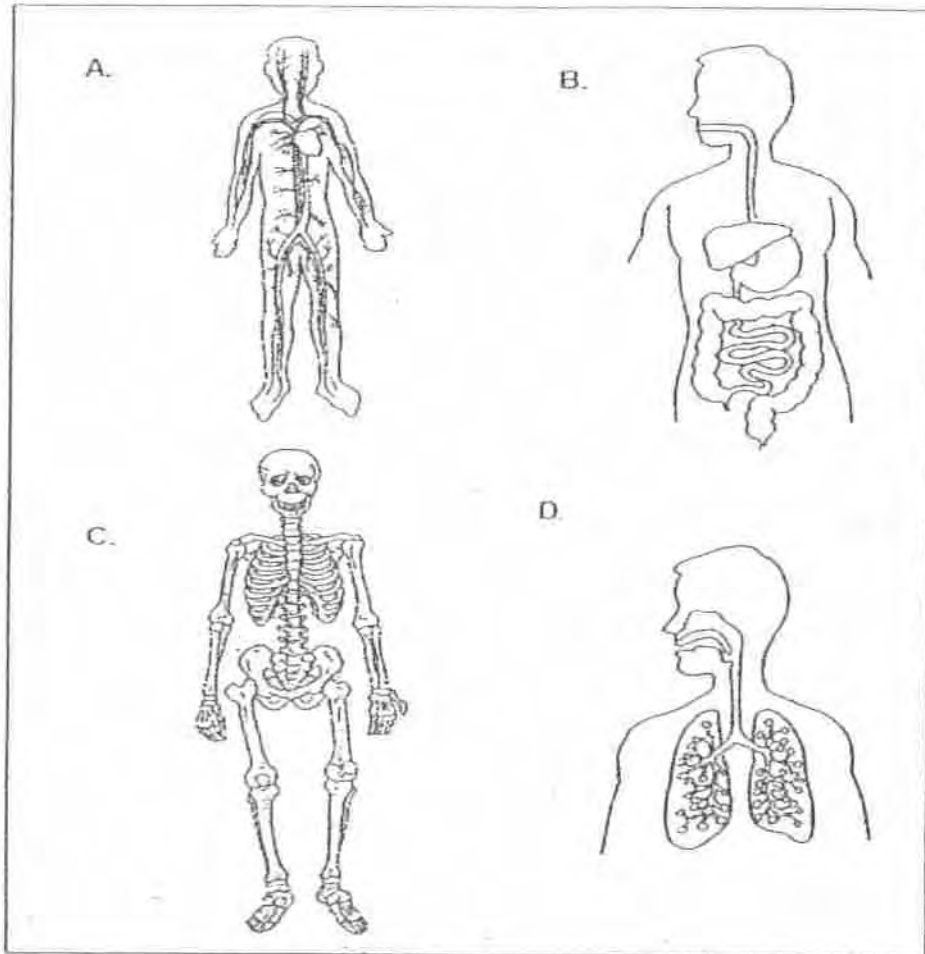

Identify the body systems that work together to send oxygen taken in to our body cells.

- (1) A and B only
- (2) A and D only
- (3) A, B and D only
- (4) A, C and D only

12. The table below compares the respiratory systems of both fish and man. Which pair/s of statements below is /are incorrect?

	FISH RESPIRATORY SYSTEM	HUMAN RESPIRATORY SYSTEM
(A)	Takes in dissolved oxygen in water.	Takes in oxygen into the body.
(B)	Carbon dioxide is removed from blood.	Carbon dioxide is removed from blood.
(C)	Gas exchange takes place in the gills.	Gas exchange takes place in the lungs.
(D)	Gills are protected by gill covers.	Lungs are protected by the ribcage.

- (1) A only
- (2) A and B only
- (3) All of the above
- (4) None of the above

13. The diagram shows two leaves which are similar in some ways.

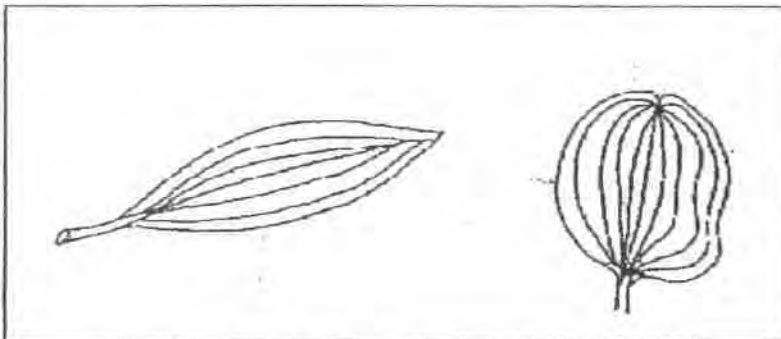

From what you can observe in the diagram, how are the two leaves similar?

- (1) They are green in colour.
- (2) They have lobed edges.
- (3) Their veins are of the same pattern.
- (4) Their surfaces are of the same roughness.



14. The diagram below represents the human circulatory system.

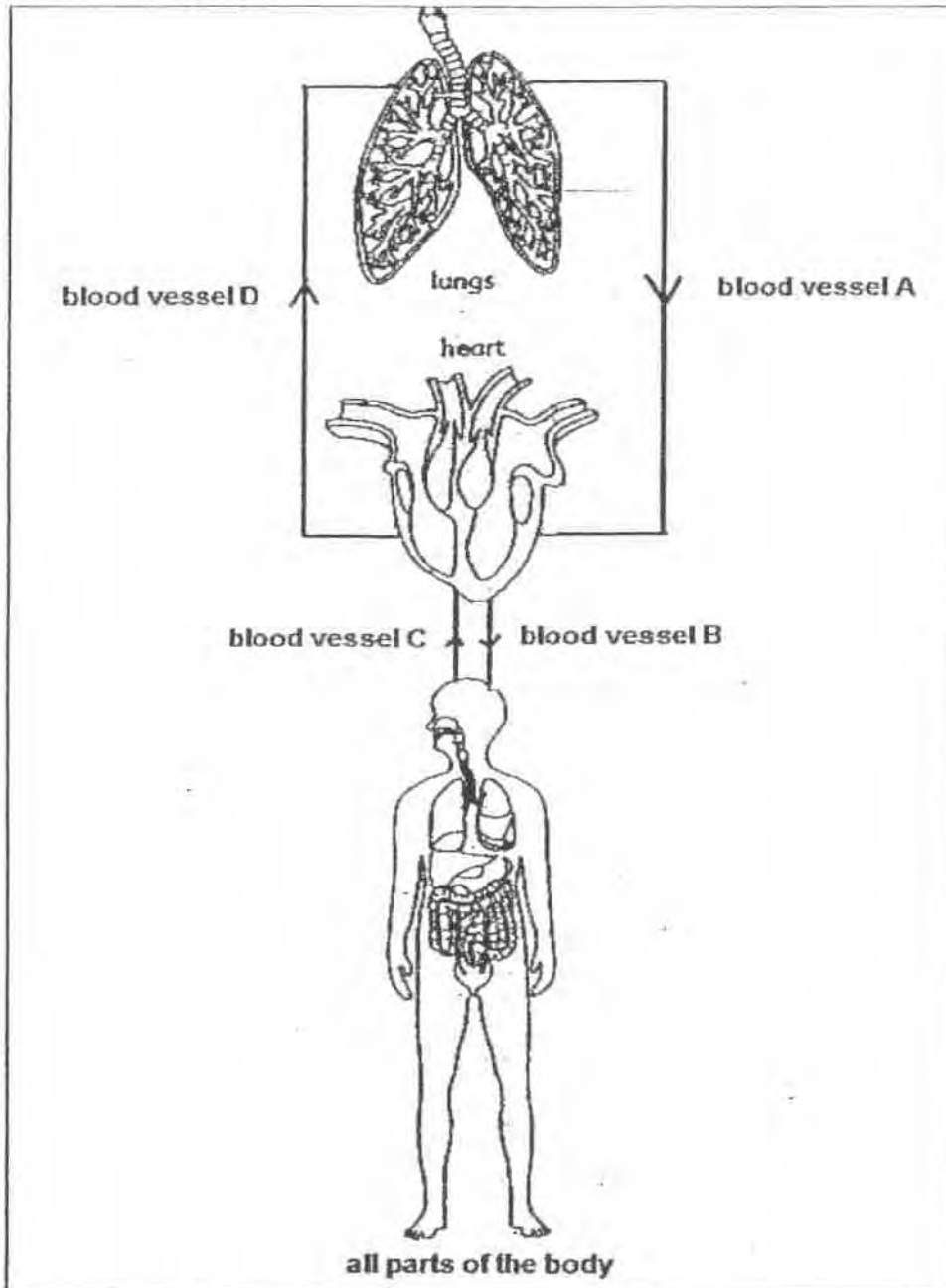

Which blood vessels carry blood poor in oxygen?

- (1) Blood vessel A only.
- (2) Blood vessel D only.
- (3) Blood vessels A and B only.
- (4) Blood vessels C and D only.

15. Sam removed an outer ring of a stem from a plant, as a result the xylem and phloem tubes were removed as shown in the diagram.

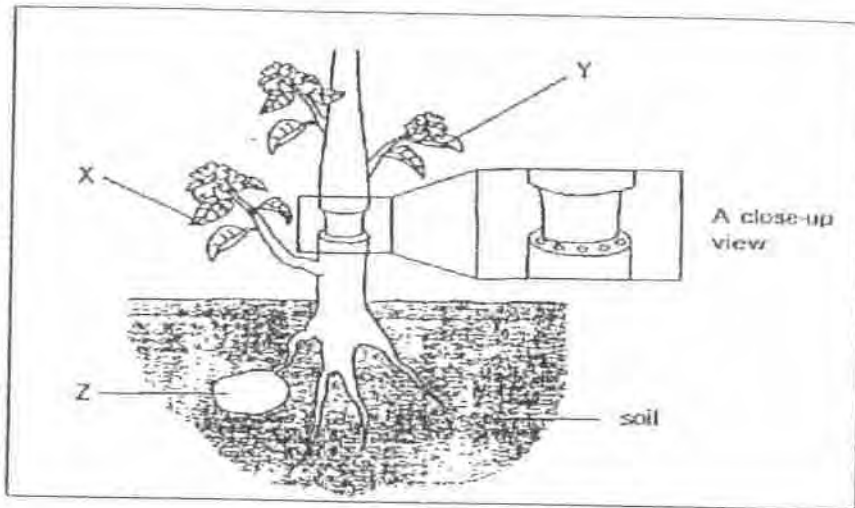

After a few weeks, it was observed that Z grew bigger. Which one of the following statements best explains the observation.

- (1) Food is made by Z itself.
  - (2) Food is transported to Z from Y.
  - (3) Food is transported to Z from X.
  - (4) Food is absorbed by Z from the soil.
16. The diagram below shows a kettle.

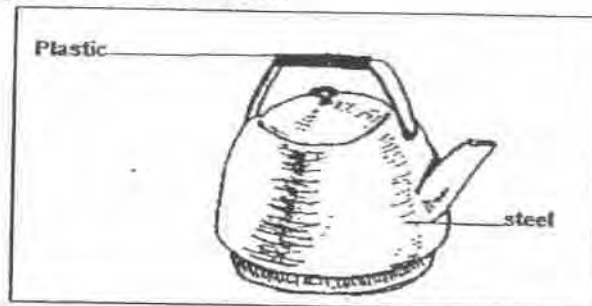

Which one of the following best explains why steel and plastic are used?

	Steel	Plastic
(1)	Good conductor of heat	Poor conductor of heat
(2)	Poor conductor of heat	Good conductor of heat
(3)	Cannot bend easily	Can be bent easily
(4)	High melting point	High melting point

17.

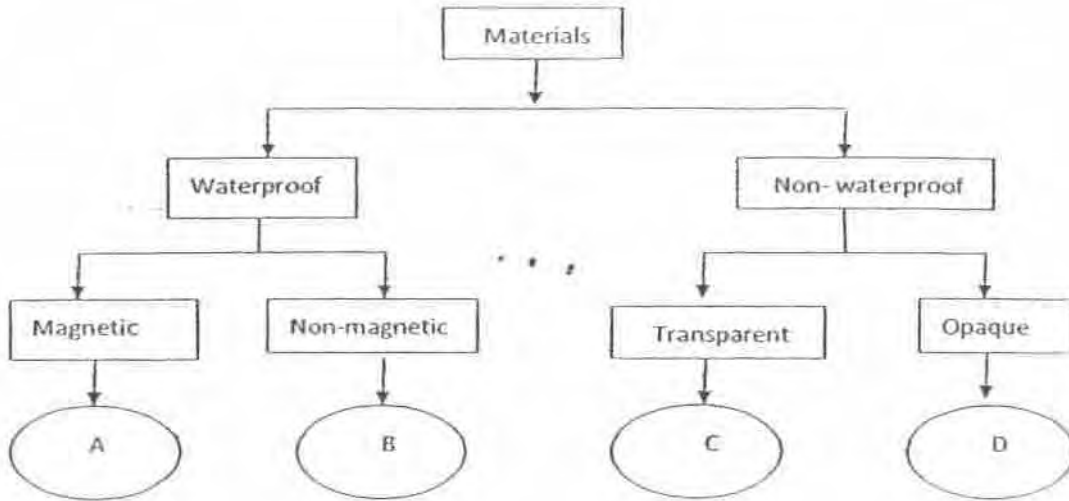

Which of the following could "D" possibly be?

- P : Kitchen towel
- Q : Candle wax
- R : Newspaper
- S : Copper pipe

- (1) P and Q
- (2) P and R
- (3) R and S
- (4) Q and S

18. Look at the list of materials.

Iron	Plastics	Glass	Diamond	Copper	Rubber	Steel
------	----------	-------	---------	--------	--------	-------

Which one of the following classification is correct?

- (1) Plastics and rubber are hard materials, the rest are soft materials.
- (2) Iron and steel are metals and magnetic but the rest are not.
- (3) Copper and iron are good conductors of heat but the rest are not.
- (4) Glass, diamond and steel are strong and hard materials while the rest are not.

19. The following diagram shows a flowchart. Analyse the flowchart and answer the question.

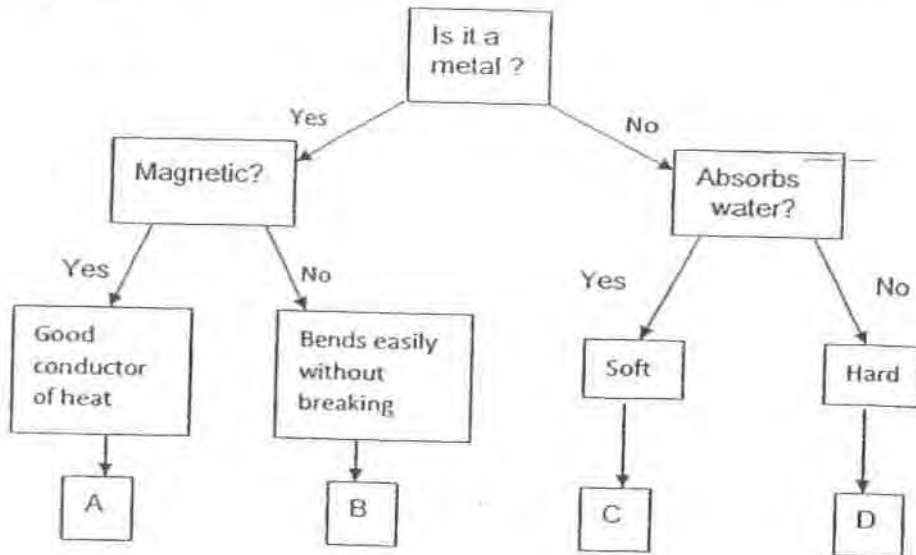

What substances could A, B, C and D represent?

	A	B	C	D
(1)	Steel wire	Copper wire	Tissue paper	Marble
(2)	Copper wire	Nichrome wire	Marble	Tissue paper
(3)	Nichrome wire	Steel wire	Brick	Rock
(4)	Steel wire	Copper wire	Rock	Brick

20. The table below shows the melting and boiling points of three substances, A, B and C.

Substance	Melting point (°C)	Boiling point (°C)
A	12	231
B	163	628
C	-46	55

Which substance(s) will be a liquid at 46 °C?

- (1) A only
- (2) A and C only
- (3) B and C only
- (4) A, B and C.

21. Study the classification chart below.

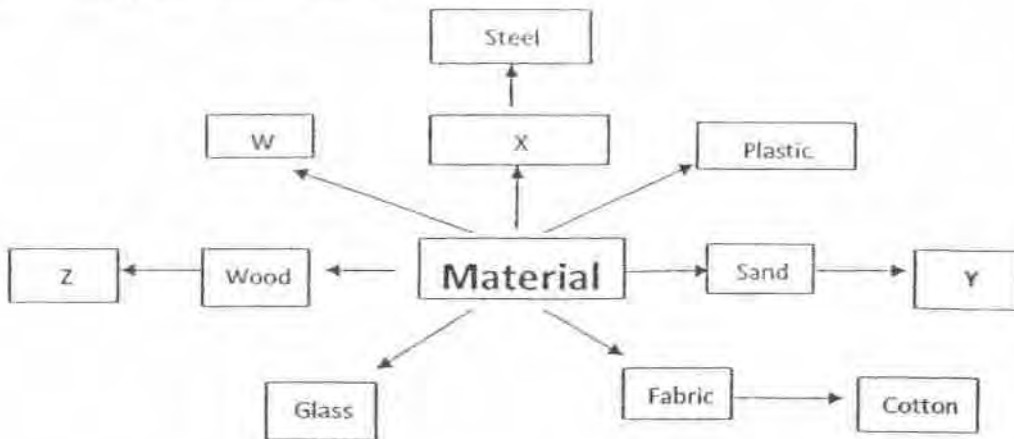

Identify W, X, Y and Z.

	W	X	Y	Z
(1)	Clay	Paper	Metals	Rubber
(2)	Metals	Rubber	Paper	Clay
(3)	Paper	Clay	Rubber	Metals
(4)	Rubber	Metals	Clay	Paper

22. Tony poured an equal amount of water into each funnel in the two set-ups as shown below.

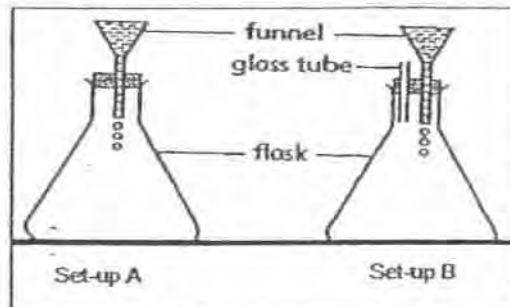

Water in Set-up A stopped flowing into the flask after a while but all the water in Set-up B flowed into the flask in a short time.

Which one of the following statements explains the observations in the experiment?

- (1) Air and water have mass but have no definite shape.
- (2) The funnel in Set-up B is better than the funnel in Set-up A.
- (3) Gravity acts on water in Set-up B but does not act on water in Set-up A.
- (4) Air in the flask in Set-up B can escape through the glass tube but air in Set-up A cannot.

23.

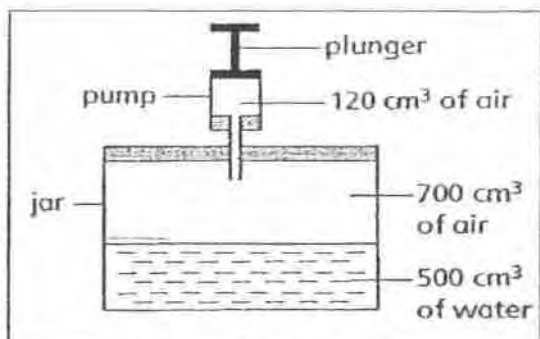

The diagram above shows a pump that has been attached to a 1200 cm<sup>3</sup> jar. The jar contains 700 cm<sup>3</sup> of air and 500 cm<sup>3</sup> of water while the pump contains 120 cm<sup>3</sup> of air. If the air in the pump is pushed into the jar, the volume of air in the jar will become \_\_\_\_\_ cm<sup>3</sup>.

- (1) 120
- (2) 700
- (3) 820
- (4) 1200

24. Study the diagram below.

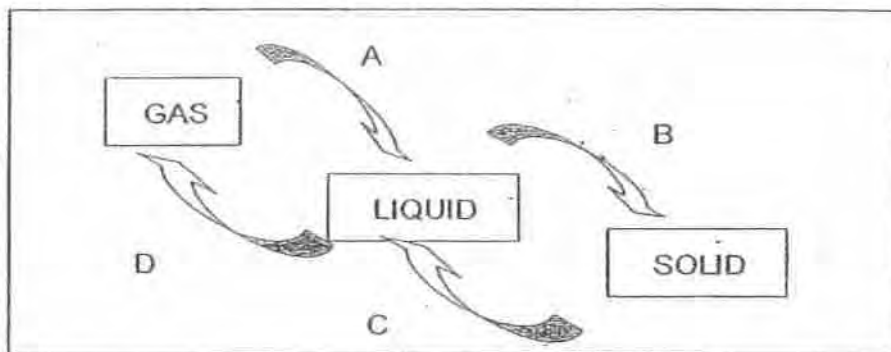

What do the processes, A, B, C and D represent?

	A	B	C	D
(1)	Condensation	Freezing	Melting	Evaporation
(2)	Evaporation	Boiling	Freezing	Condensation
(3)	Evaporation	Freezing	Melting	Condensation
(4)	Boiling	Evaporation	Condensation	Melting

25. The experiments below show some properties of air.

Which properties of air are stated correctly?

The diagram shows four experiments labeled A, B, C, and D, each with a corresponding text box:

- A:** A balance scale with two balloons hanging from it. One side is lower than the other. A text box says "Air has mass."
- B:** Two beakers of water. The left one has a ping pong ball floating on top. The right one has a ping pong ball pushed down. A text box says "Air expands when heated."
- C:** Two glasses of water. The left one has ice cubes and is labeled "icy cold water". The right one has a water droplet on the surface. A text box says "Oxygen becomes water when cooled."
- D:** A life buoy and a ring. A text box says "Air takes up space."

- (1) A and D only
- (2) B and C only
- (3) A, B and D only
- (4) A, B, C and D only

26. Study the diagrams below.

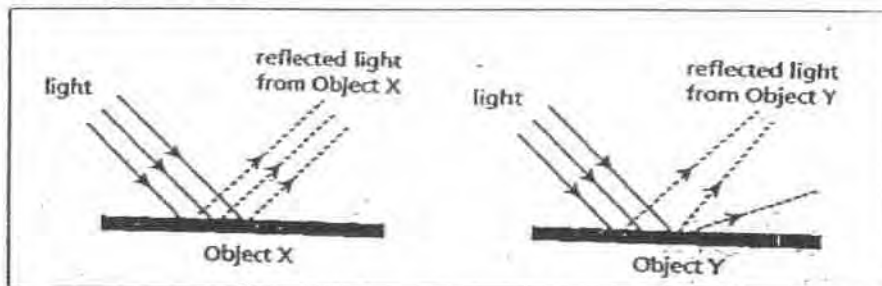

What can you conclude from the information given?

- (1) Object X is transparent but Object Y is opaque.
- (2) Object X is a source of light but Object Y is not.
- (3) Object X has a rough surface but Object Y has a smooth surface.
- (4) Object X has a smooth surface but Object Y has a rough surface.

27. Observe the shape of the two objects shown below.

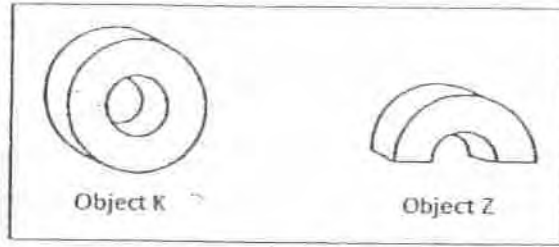

Object K is made of steel and Object Z is made of copper.  
What will the shadow look like when Object K and Object Z are placed between the light source and the screen as shown below.

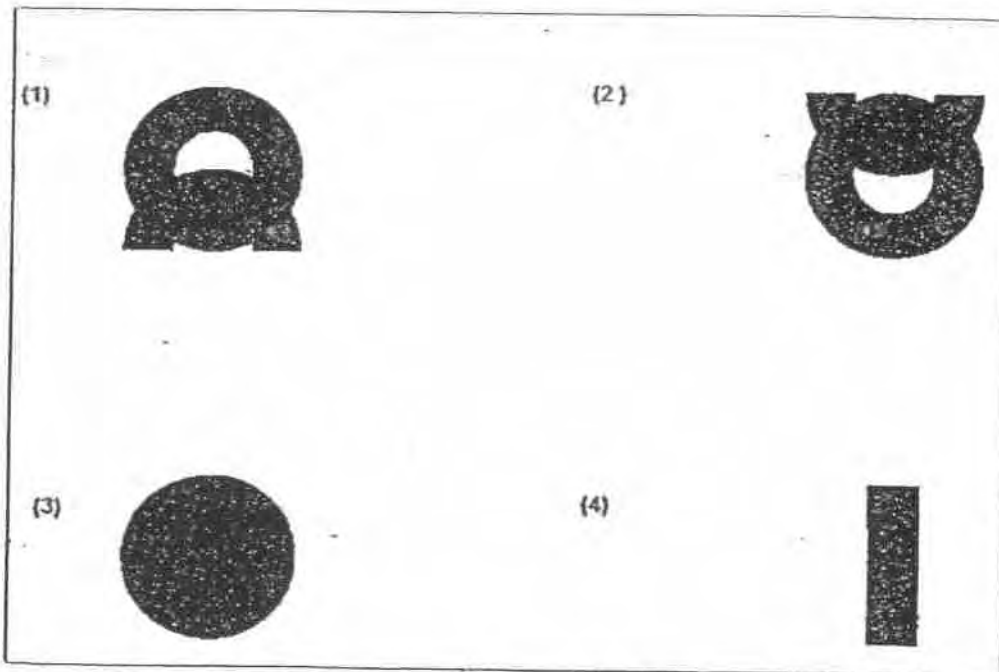
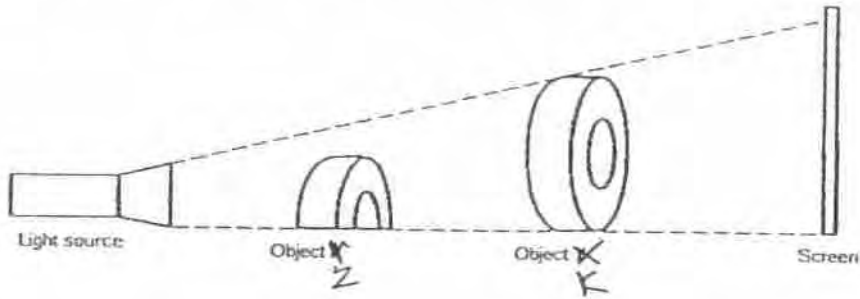



28. Peter poured 500 ml of boiling water into a beaker and left it at room temperature. After 15 minutes, he poured another 300 ml of boiling water into the same beaker, stirred it and left it for another 15 minutes. Which one of the following graphs shows the most possible changes in the temperature of water in the beaker?

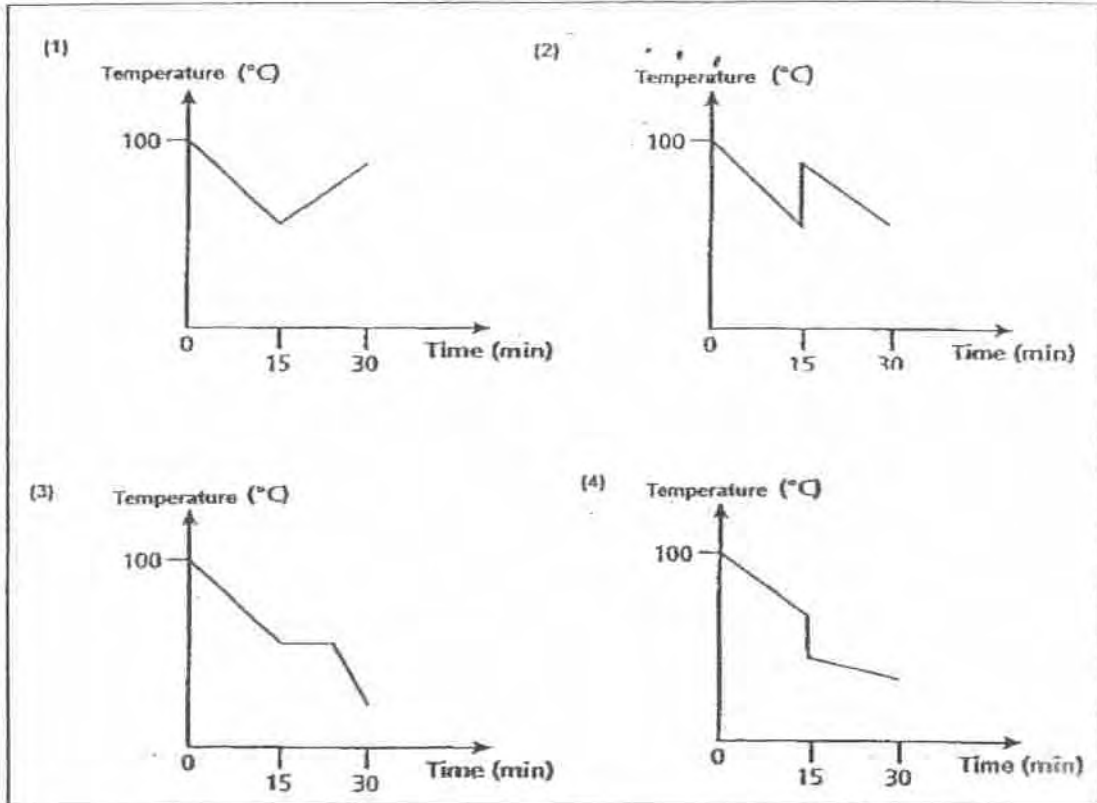

29. Kimberly set up an experiment as shown below. When she inserted a piece of glass between the paper clip and the magnet, the clip remained in its original position.

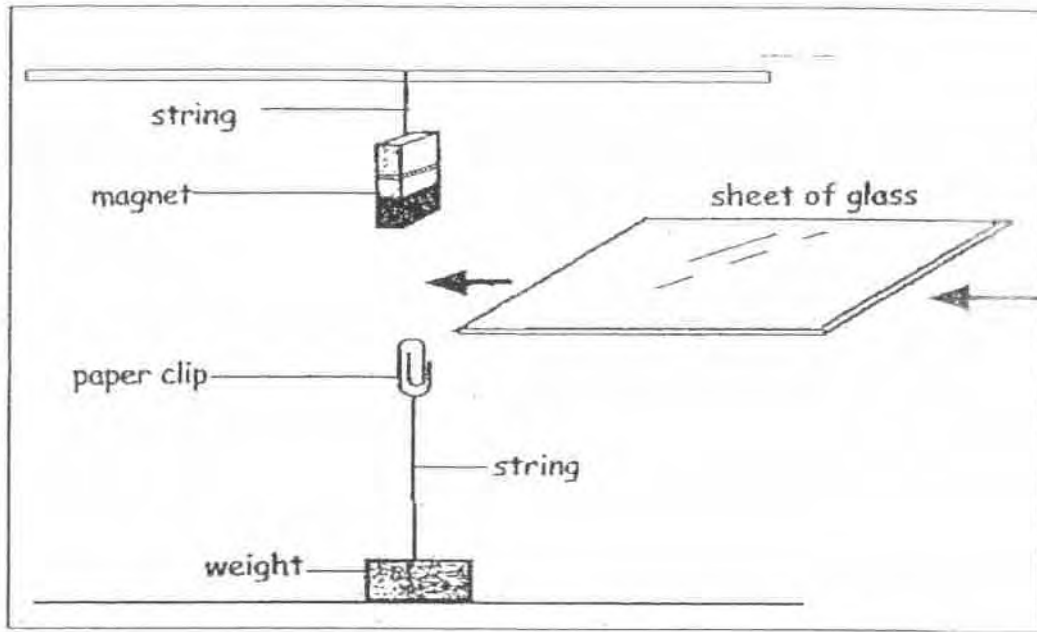

What conclusion could Kimberly draw from this experiment?

- (1) Glass is a magnetic material.
- (2) The bar magnet is a strong one.
- (3) The sheet of glass attracts the paper clip.
- (4) Glass allows the magnetic force to pass through.

30. Karen set up an experiment as shown below. She wants to find out which material is better for making towels.

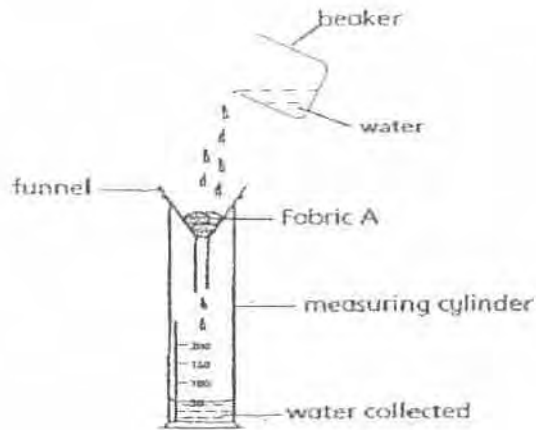

She placed a piece of Material A in the funnel and poured water into the funnel. The water flowed through Material A and the water was collected in a measuring cylinder. Karen then repeated the experiment with Material B and then with Material C. The results are recorded in the table below.

Material	Amount of water collected (ml)
A	93
B	87
C	60

However, her friend told her that her experiment was not a fair test and her results are therefore not accurate. What should Karen do to ensure that her test is a fair one?

Karen should \_\_\_\_\_.

- A : keep the size of the material constant.
- B : should use the same volume of water.
- C : change the size of the measuring cylinder.
- D : should pour the water into the funnel at the same rate.

- (1) A only
- (2) B and D only
- (3) A and B only
- (4) A, B and D only.

METHODIST GIRLS' SCHOOL (PRIMARY)  
CONTINUAL ASSESSMENT 1  
SCIENCE – PRIMARY FIVE  
2010

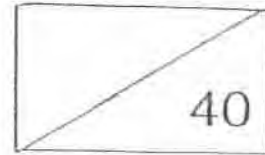

NAME : \_\_\_\_\_

DATE: 2<sup>ND</sup> March 2010

CLASS : \_\_\_\_\_

Section B : (40 marks)

Write your answers to questions 31 to 46 in the blanks provided.

31. The diagrams below show two animals.

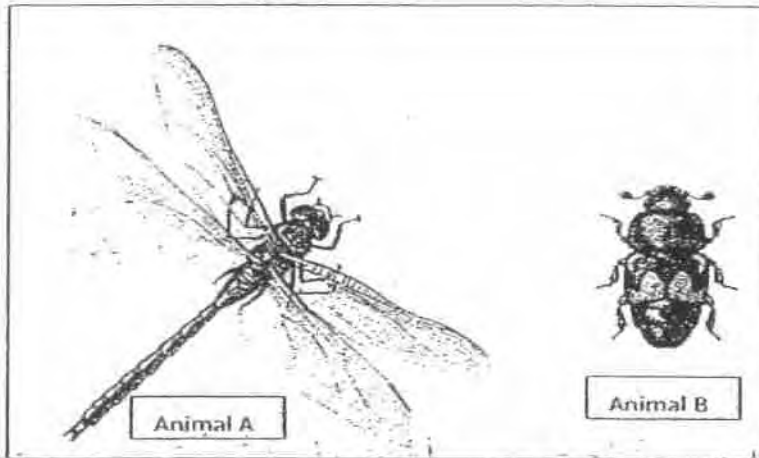

- (a) In what ways are they similar? State two observable similarities.  
(Do not compare shape, size and colour)

(1m)

---

---

The diagram below shows an imaginary creature:



- (b) Is it an insect? Give one reason to support your answer.

(1m)

---

---

32.

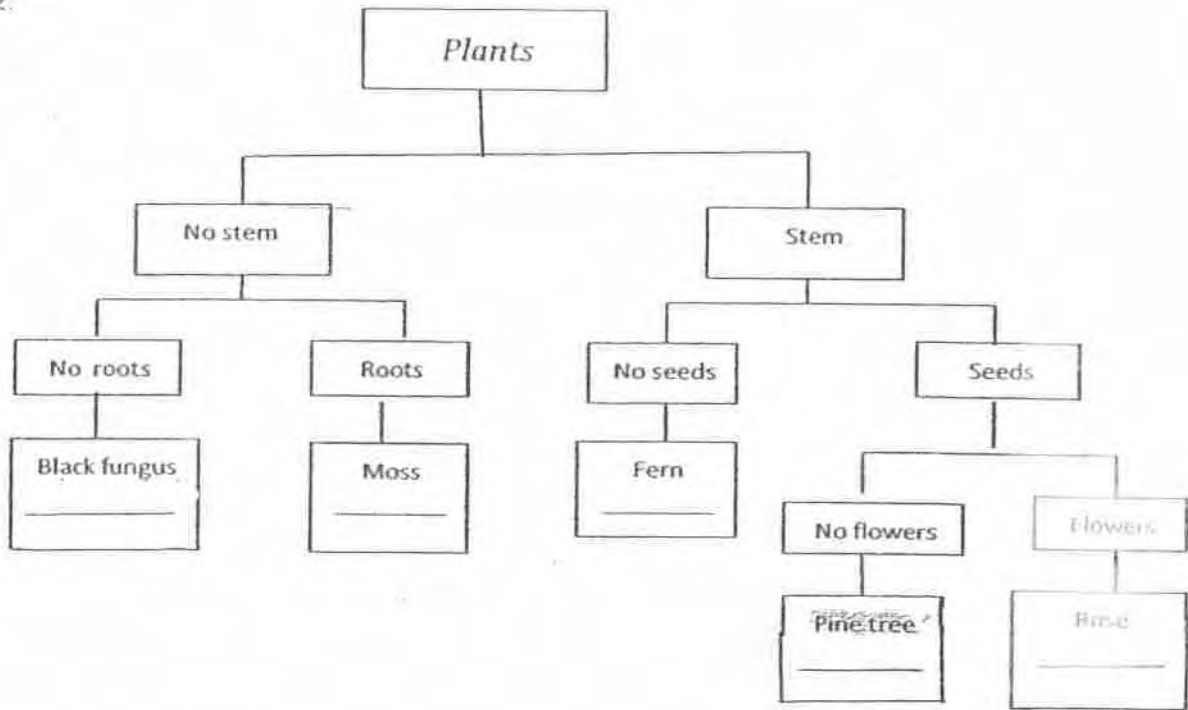

(a) Based on the classification table, what are the characteristics of the Pine tree? (1½m)

---

---

---

(b) Put 'coconut trees' and 'mould' in the above classification table. (1m)

33. Two fish bowls P and Q contain 2 fishes, same number of pebbles and same amount of water. Bowl P has some water plants in it.

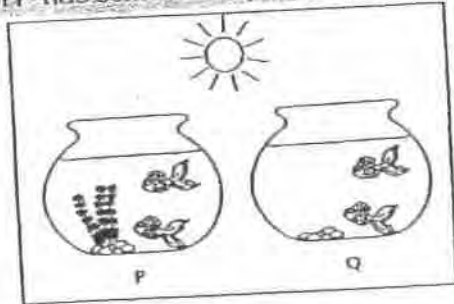

The fish in Bowl P survived but the fish in Bowl Q died at the end of two days.

- (a) Give a reason why the fish in Bowl P survived? (2m)

---

- (b) Why did the fish in Bowl P die faster than the fish in Bowl Q when Bowl P was covered with a piece of thick black cloth? (2m)

---

---

34. The diagram below shows the two sets of muscles in the arm, biceps and triceps.

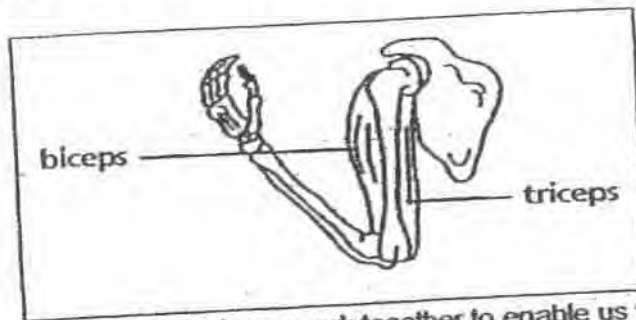

- (a) How do the biceps and triceps work together to enable us to bend our arms at the elbow? (1m)

---

- (b) What is the system that works together with our muscular system to make us move some of our body parts? (1m)

---

---

35. Study the graph below and answer the questions that follow.

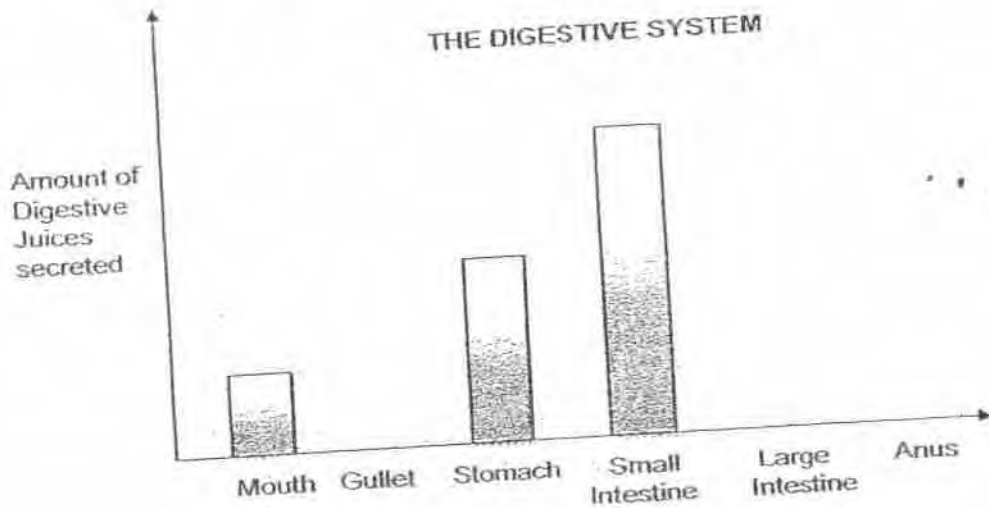

(a) In which part/s of the digestive system does digestion of food occur? (1m)

(b) State the correct part of the digestive system in the table below. (2m)

	Function	Part of the digestive system
(1)	Storage of undigested food	
(2)	Removal of water from undigested food	
(3)	Part through which undigested food leaves the body	
(4)	Food is digested and absorbed into the bloodstream	

(c) Why are our teeth important for digestion? (1m)

---

---

---

36. The diagram below shows a seedling.

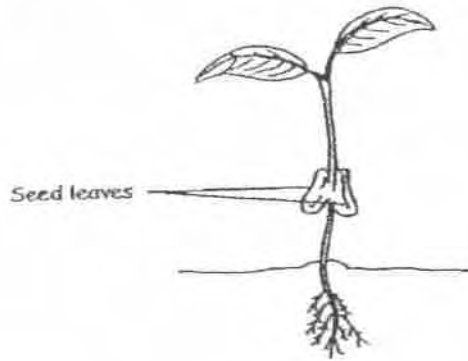

(a) What is the function of the seed leaves? (1m)

---

---

(b) Which part of the seedling will appear first? (1m)

---

(c) Is the seedling able to make food at this stage? Why? (1m)

---

---



37. Robin planted a green bean seed each in five pots, A, B, C, D and E. They were placed under different conditions for three days as shown in the table below.

Pot	Air	Water	Light	Temperature	Result
A	√	√	x	25 °C	Root and shoot grew.
B	√	√	√	5 °C	No change observed.
C	x	√	√	25 °C	No change observed.
D	√	—√—	√	25 °C	Root and shoot grew.
E	√	x	√	25°C	No change observed.

- (a) What can you conclude about the conditions necessary for the green bean seeds to germinate? (1m)

---



---

- (b) Explain clearly what would happen to the five green beans seeds after 3 weeks if they were left under the same conditions in each pot? (2m)

---



---

38. Some blobs of wax are placed on a silver ring as shown below.

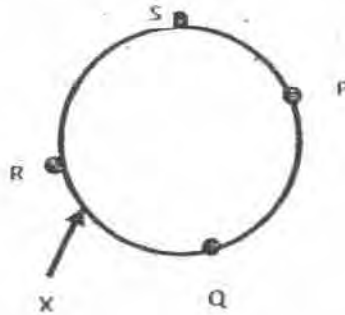

If the ring is heated at X, what will be the order for the blobs of wax to melt? Arrange the blobs of wax in order, starting with the blobs that will melt first.

(2m)

First ————— last

39. Henry carried out an experiment to show that different liquids expand to different extent when they gain heat. The diagram below shows his set-up.

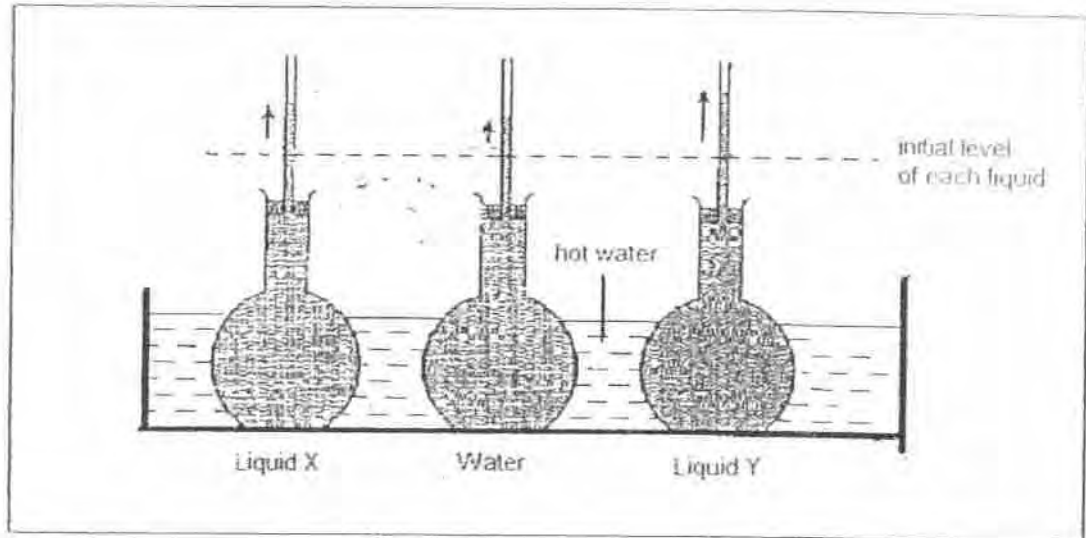

- (a) Henry had kept the initial level of each liquid constant before putting the flasks into a hot water bath. State another variable that had to be kept constant. (1m)
- \_\_\_\_\_
- \_\_\_\_\_
- (b) Which liquid has the greatest increase in volume when it is heated? (1m)
- \_\_\_\_\_
- (c) What will happen to the liquid level in each flask if they are put in an icy cold water bath instead? (1m)
- \_\_\_\_\_
- \_\_\_\_\_
- (d) Give a reason for your answer in (c). (1m)
- \_\_\_\_\_
- \_\_\_\_\_

40. Sam heated some water at room temperature for 8 minutes. During this period, the water boiled. He recorded the temperature of the water every 2 minutes. The results are shown in the graph below:

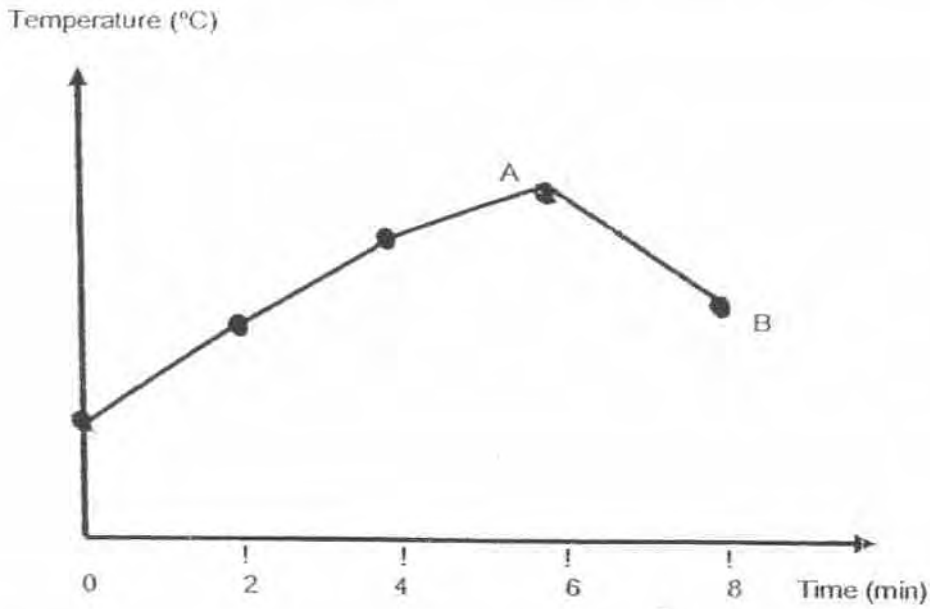

- (a) The room temperature was  $25^{\circ}\text{C}$ . Mark and label the two temperatures,  $25^{\circ}\text{C}$  and  $100^{\circ}\text{C}$  in the graph above. (2m)
- (b) What does the line AB tell you about the temperature of the water? (1m)

---

---

- (c) If Sam did not stop heating the water throughout the experiment, suggest a possible reason for the change in temperature at AB. (1m)

---

---

---

41. The set-up is used to find out if the number of dry cells affects the strength of an electromagnet.

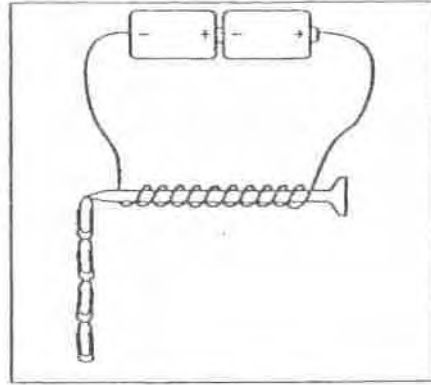

- (a) Identify the variable that must be changed when the experiment is repeated. (1m)

---

---

- (b) What 2 major variables must be kept constant so that the experiment conducted is a fair test? (2m)

---

---

---

42. The diagram shows the floor plan of Mr Li's shop.

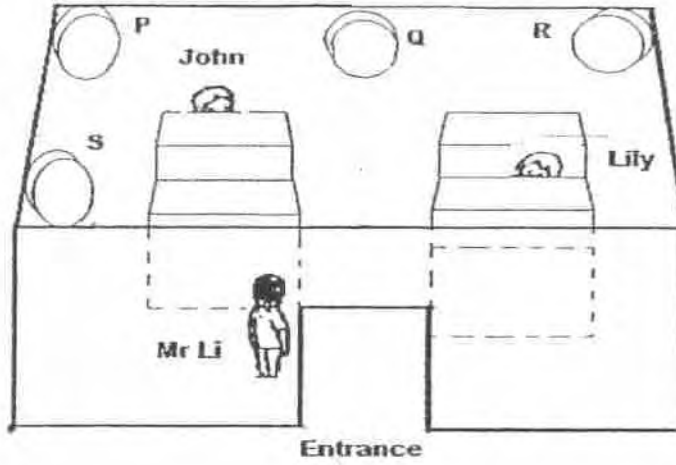

Mirrors P, Q, R and S are fixed on the ceiling at different spots as shown.

- (a) Which mirror/s will enable Mr Li to see John if he is at the entrance as shown in the diagram above? (1½m)

---

- (b) Why is it important for the mirrors to have smooth surfaces? (1m)

---

---

---

43. Vincent has four strings of the same material but of different thickness. He has the following set-up for his experiment.

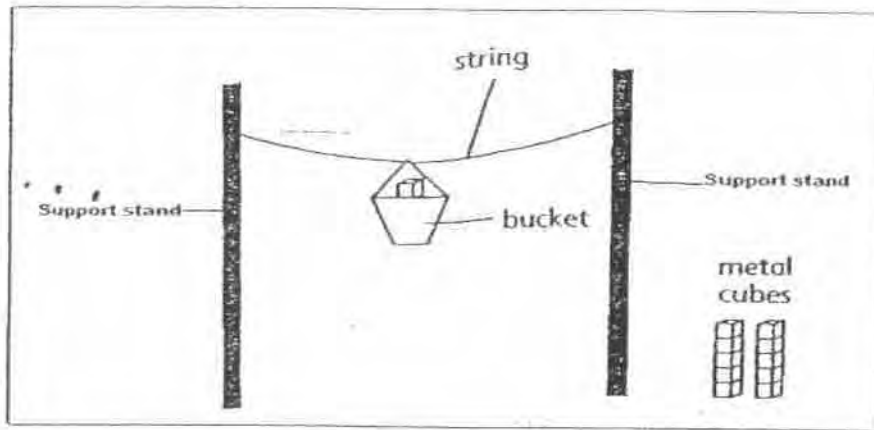

He adds a metal cube to the bucket each time until the string snaps. Then he repeats his experiment with a thicker string.

The table below shows his results.

(a)

Thickness of string (cm)	Maximum number of metal cubes in bucket
0.1	8
0.2	14
0.3	20
0.4	26

From the results shown in the table above, state the relationship between the thickness of the string and the number of metal cubes the bucket can hold before it snaps. (1m)

---

---

---

- (b) From the experiment, draw a conclusion about the strength of the strings that are made of the same material but of different thickness. (1m)

---

---

---

44.

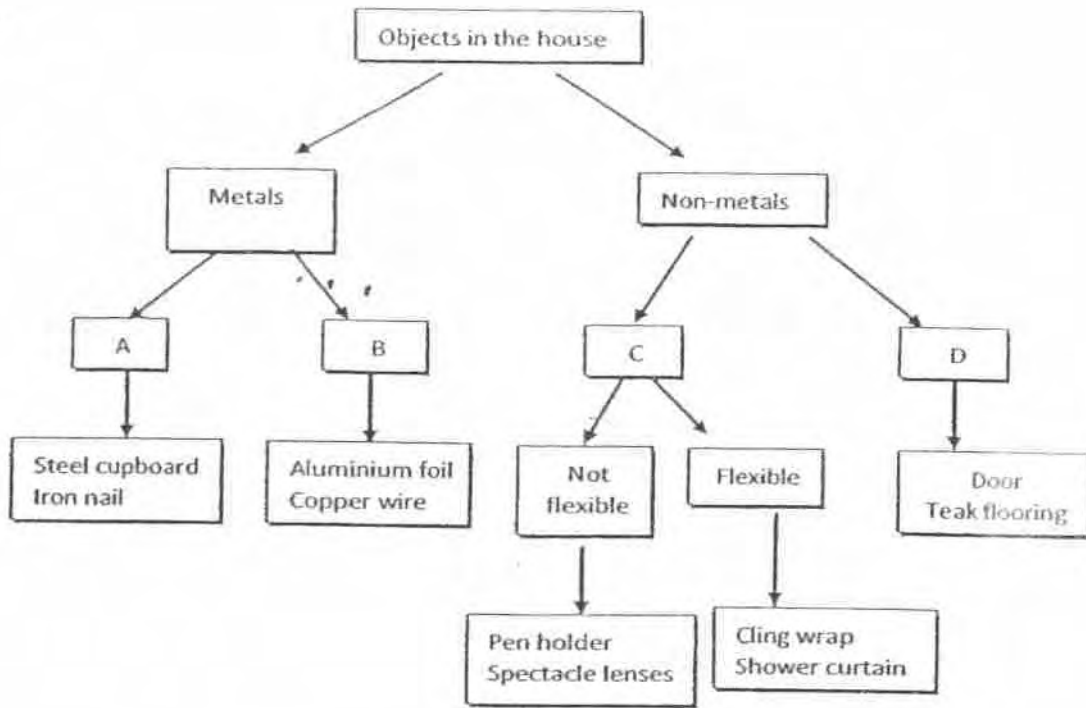

What could the groupings A, B, C and D represent?

(2m)

- A: \_\_\_\_\_
- B: \_\_\_\_\_
- C: \_\_\_\_\_
- D: \_\_\_\_\_

*End of paper*



# ANSWER SHEET

## EXAM PAPER 2010

SCHOOL : MGS PRIMARY  
SUBJECT : PRIMARY 5 SCIENCE

TERM : CA1



Q1	Q2	Q3	Q4	Q5	Q6	Q7	Q8	Q9	Q10	Q11	Q12	Q13	Q14	Q15	Q16	Q17
4	2	2	2	3	1	4	3	2	2	2	4	3	4	3	1	2

Q18	Q19	Q20	Q21	Q22	Q23	Q24	Q25	Q26	Q27	Q28	Q29	Q30
2	1	2	4	4	2	1	3	4	1	2	4	4

31)a)They have six legs and 3 body parts.

b)No, it is not an insect. As insects have six legs and three body parts, this creature is not an insect.

32)a)The characteristics of the pine tree is that it is a plant, it has a stem, it produces seeds and it does not have flowers.

b)Black fungus-----Mould                      Rose-----coconut tree

33)a)As plants take in carbon dioxide and release oxygen, the fish in Bowl p has oxygen to breath while the fish in Bowl Q does not.

b)As plants respire when there is no sunlight, it is fighting with the fish for oxygen and releasing carbon dioxide, therefore the fish in Bowl P died faster than the fish in Bowl Q.

34)a)The biceps contract and the triceps relax when we bend our arms and the biceps relax and the triceps contract when we straightened our arm.

b)It is the skeletal system.

35)a)The mouth, stomach and the small intestine.

b)1)Large intestine                      2)Large intestine                      3)Anus                      4)Small intestine

c)Our teeth work together with our saliva to help us break down the food into simpler substance faster.

36)a)The function of the seed leaves is to provide food for the seedling when it cannot make food.

b)The roots.

c)Yes, it is. As its leaves are grown, it is able to make its own food.



- 37)a)The seed needs air, water and warmth.  
b)Beans in Pot B, C and E would not grow. Pot A would grow and then would wilt and die and Pot D would grow into a young plant as the conditions were right.

38)R, Q, S p

- 39)a)The size of the flask.  
b)Liquid Y.  
c)The level of the liquid would go down.  
d)The liquid will contract when they lose heat to the ice water in the water bath.

40)a) Temperature (°C)

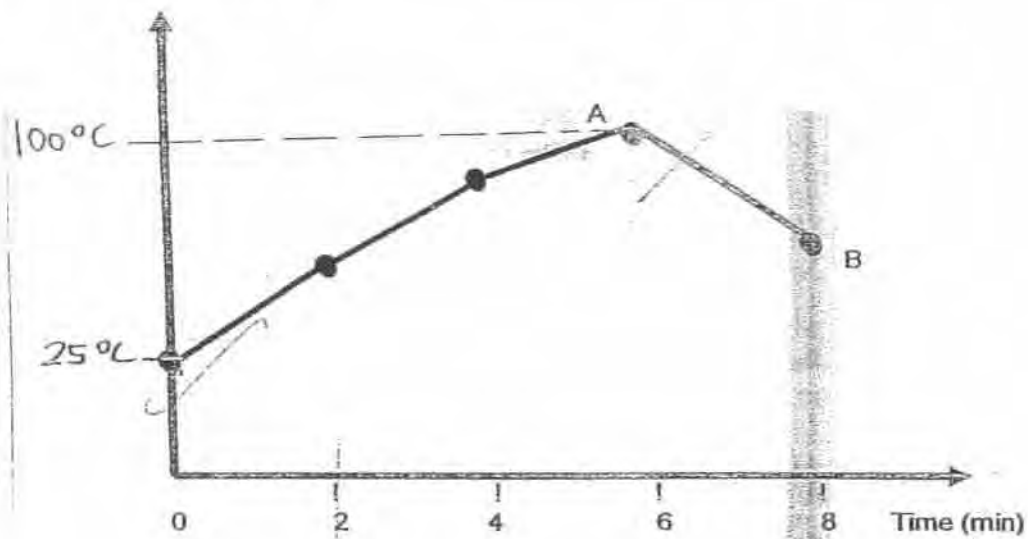

- b)The temperature of the water decreased.  
c)Sam could have added some ice.

- 41)a)The number of dry cells.  
b)The length of wire and the number of coils.

- 42)a)Mirror P and Q. Mirror P, Q and R.  
b)To get sharp images as smooth surface allows regular reflection of light rays.

- 43)a)The thickness of the string is dependent on the number of metal cubes.  
b)The thicker the strings, the stronger they are.

- 44)A: magnetic  
B: Non-magnetic  
C: Plastic  
D: Wood