

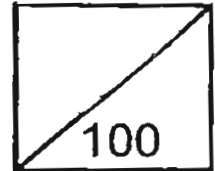

**Rosyth School**  
**Semestral Examination for 2011**  
**STANDARD SCIENCE**  
**Primary 5**



Name: \_\_\_\_\_

Total  
Marks:

Class: Pr \_\_\_\_\_

Register No. \_\_\_\_\_

Duration: 1 h 45 min

Date: 1 Nov 2011

Parent's Signature: \_\_\_\_\_

---

## Booklet A

Instructions to Pupils:

1. Do not open the booklets until you are told to do so.
2. Follow all instructions carefully.
3. This paper consists of 2 booklets, Booklet A and Booklet B.
4. For questions 1 to 30 in Booklet A, shade the correct ovals on the Optical Answer Sheet (OAS) provided using a 2B pencil.
5. For questions 31 to 44, give your answers in the spaces given in the Booklet B.

	<b>Maximum</b>	<b>Marks Obtained</b>
<b>Booklet A</b>	<b>60 marks</b>	
<b>Booklet B</b>	<b>40 marks</b>	
<b>Total</b>	<b>100 marks</b>	

\* This booklet consists of 17 pages.

This paper is not to be reproduced in part or whole without the permission of the Principal.

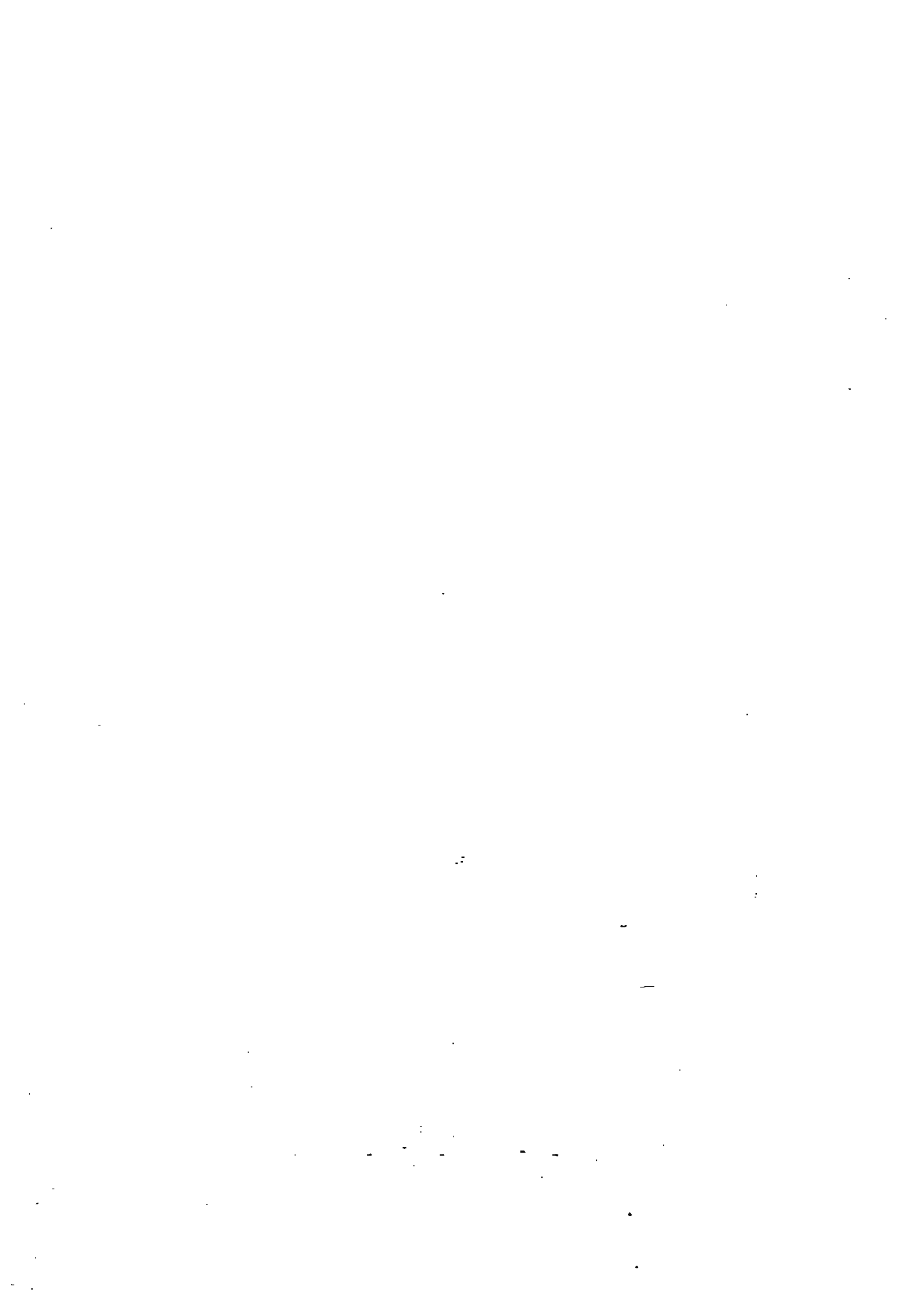

**Part I (60 Marks)**

For each question from 1 to 30, four options are given. One of them is the correct answer. Make your choice (1, 2, 3 or 4). **Shade the correct oval (1, 2, 3 or 4) on the Optical Answer Sheet.**

1. The graph below shows the changes in the height of a pupil over a period of time.

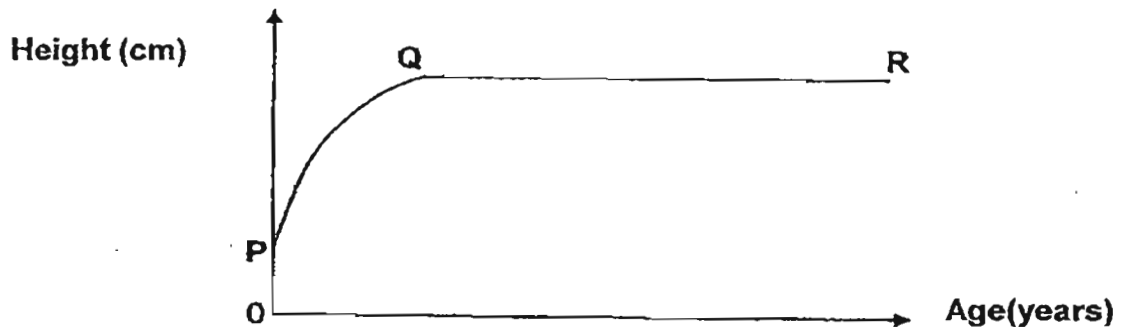

After studying the graph, three pupils made the following statements.

Ali: From P to Q, there is an increase in height as the cells in the body increases in number.

Kelly: From P to Q, there is an increase in height as the cells in the body grows bigger in size and become more mature.

Jane: From Q to R, there is no change in height because there is no cell division.

Which of the following pupils made the correct deductions?

(1) Ali only

(2) Kelly only

(3) Ali and Jane only

(4) Ali, Jane and Kelly

2. The flow chart below shows the differences between some cells.

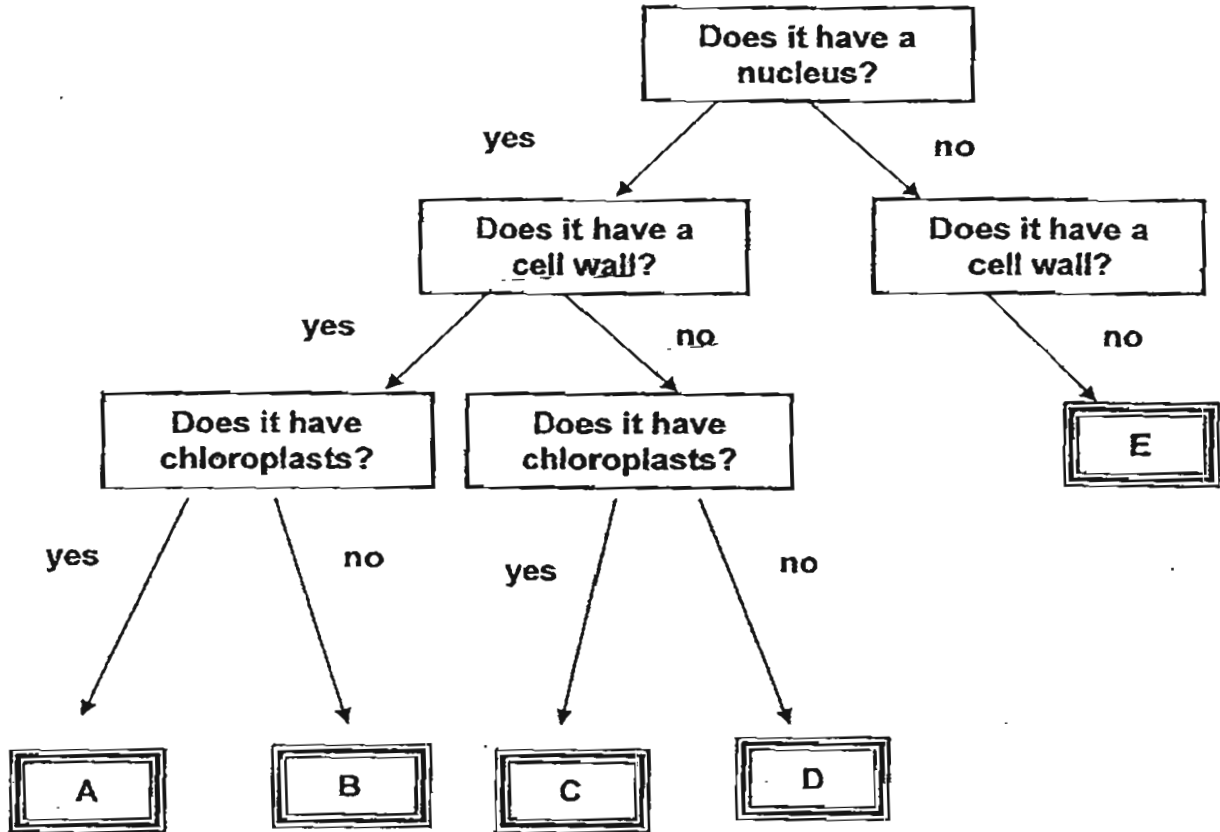

Based on the information above four pupils made the following statements:

Alice: Cells A and B can be plant cells.

Betty: Cells D and E can be animal cells.

Cathy: Cells A and C are able to photosynthesise.

Dolly: Cell E is not a cell as it does not have a nucleus.

Which of these pupil(s) made (an) incorrect statement/s

(1) Betty only

(2) Dolly only

(3) Alice and Cathy only

(4) Betty and Dolly only

3. Arrows X and Y in the diagram below represent the transportation of water and food respectively, from one part of a plant to another. A and B represent the different parts of the plant.

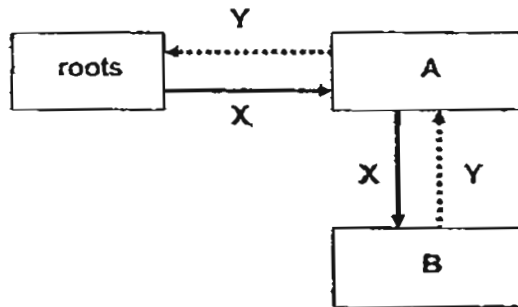

Which one of the following correctly represents A and B?

	A	B
(1)	leaf	stem
(2)	fruit	leaf
(3)	stem	leaf
(4)	stem	fruit

4. The diagram below shows the cross-sections of a stem and a root. Which parts are responsible for the transport of sugars in plants?

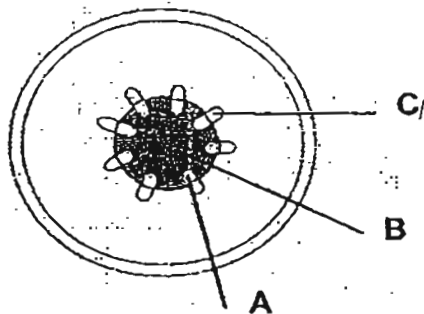

**Cross section of stem**

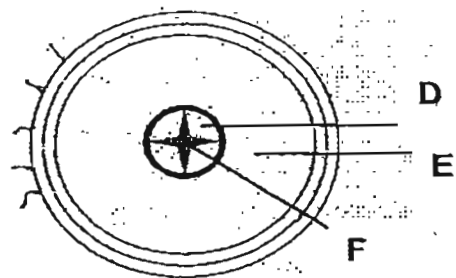

**Cross section of root**

- |             |             |
|-------------|-------------|
| (1) A and F | (2) C and D |
| (3) B and E | (4) C and E |

5. Bala wanted to conduct an experiment to find out whether Plant X or Plant Y takes in more water.

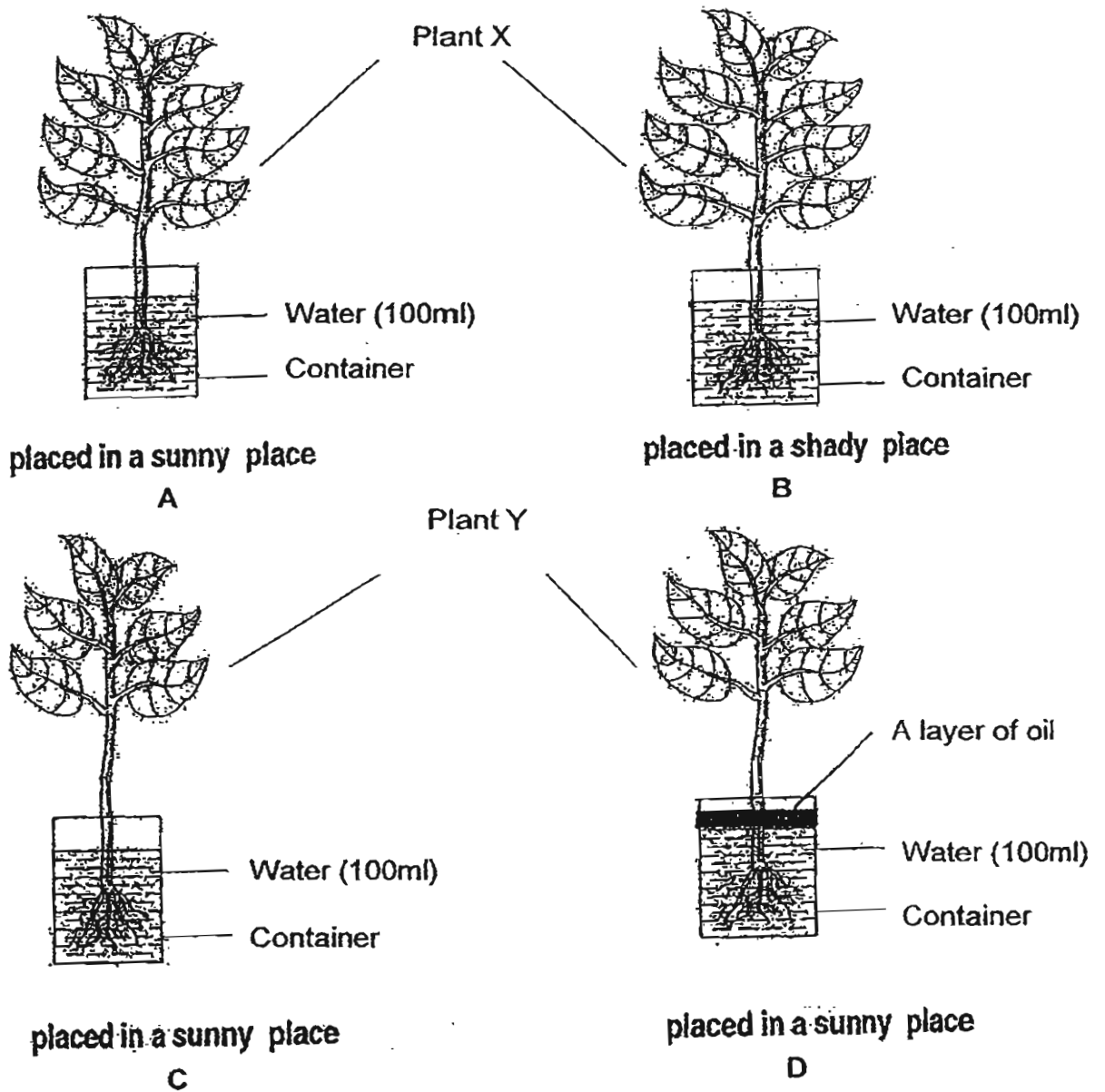

Which pair of the above set-up is the most suitable for him to conduct the experiment?

- (1) A and C
- (2) A and D
- (3) B and C
- (4) B and D

6. The diagram below represents our circulatory system.

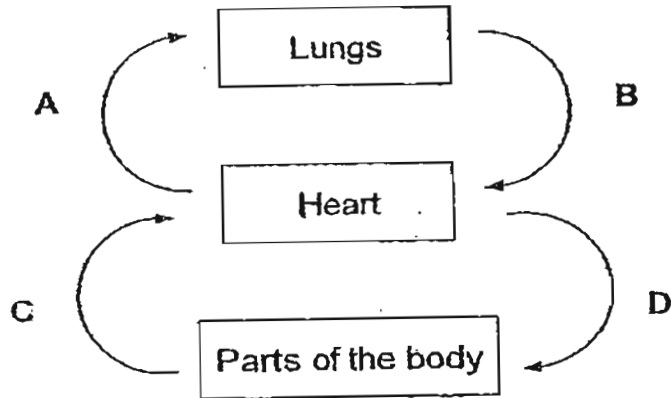

Which pair of blood vessels always carries blood that is rich in oxygen?

- (1) A and B
- (2) A and C
- (3) B and D
- (4) C and D

7. The following diagram shows a part of the lungs.

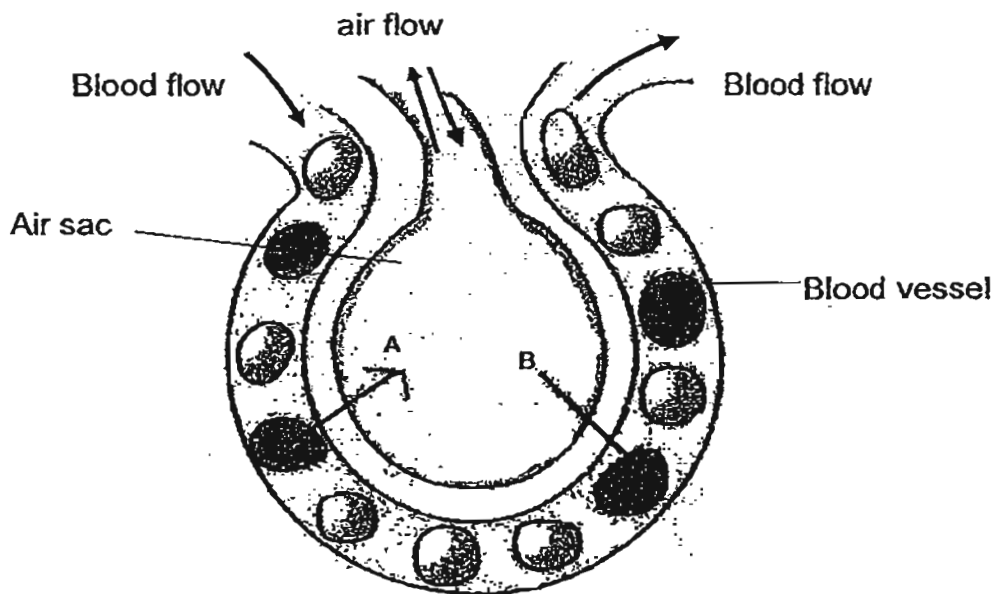

Which one of the following correctly identifies the substances represented by arrows A and B?

	A	B
(1)	Oxygen	Water
(2)	Oxygen	Carbon dioxide
(3)	Carbon dioxide	Oxygen
(4)	Water	Carbon dioxide

8. Which one of the following shows the correct route for blood to travel away from the leg in the human body?

- (1) leg → heart → lungs
- (2) leg → lungs → heart
- (3) leg → lungs → heart → lungs
- (4) leg → hand → heart → lungs

Study the diagram below to answer questions 9 and 10.

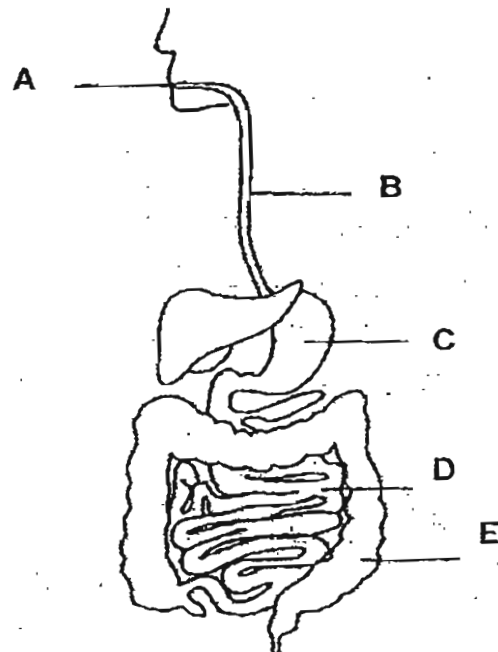

9. In which of the regions, ( A, B, C, D or E ) would food substances not be broken down?

- (1) A and C only
- (2) B and E only
- (3) B, C and D only
- (4) A, C and D only

10. Which one of the above parts works closely with the circulatory system to absorb nutrients into the body?

- (1) A
- (2) C
- (3) D
- (4) E



11. Which of the following conditions would most likely reduce the population of earthworms in a leaf litter habitat?

- A: Increase in the intensity of sunlight
- B: Increase in the amount of moisture
- C: Increase in the amount of decaying leaves
- D: Increase in the amount of pesticide sprayed onto the soil

- (1) A and B only
- (2) B and C only
- (3) A and D only
- (4) A, B, C and D

12. Jane wants to find out which type of soil, A, B, C or D is the most suitable for the growth of mangrove plants. She set up the experiment as shown in the diagram below. She lined the funnel with filter paper to prevent soil particles from entering the measuring cylinder. She measured the amount of water collected in the measuring cylinder after five minutes.

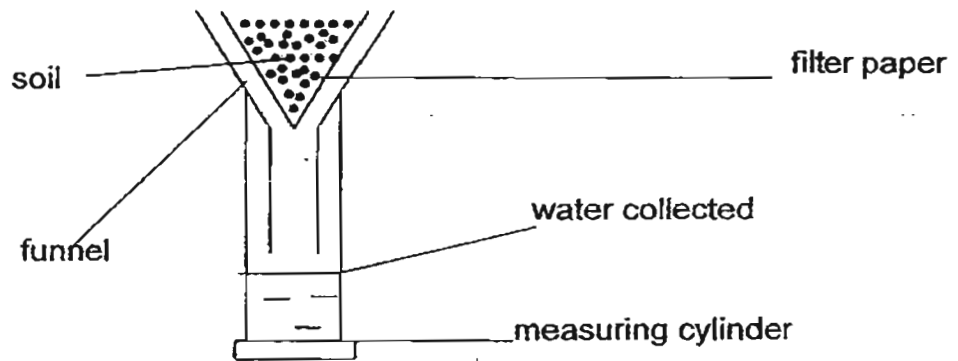

Jane recorded her findings in the table below.

Type of soil	A	B	C	D
Amount of water collected after five minutes(millilitres)	25	23	35	18

Which type of soil would be the most suitable for the growth of mangrove plants?

- (1) A
- (2) B
- (3) C
- (4) D

13. Study the food chain below.



Which of the following statements about the food chain is correct?

- (1) Organism J is a producer and it does not require energy from any sources.
- (2) Organism M receives the most energy as it is at the end of the food chain.
- (3) Not all the energy from Organism K can be transferred to Organism L.
- (4) More energy is transferred from Organism L to Organism M than from Organism K to Organism L.

14. The diagram below shows a food web in a pond.

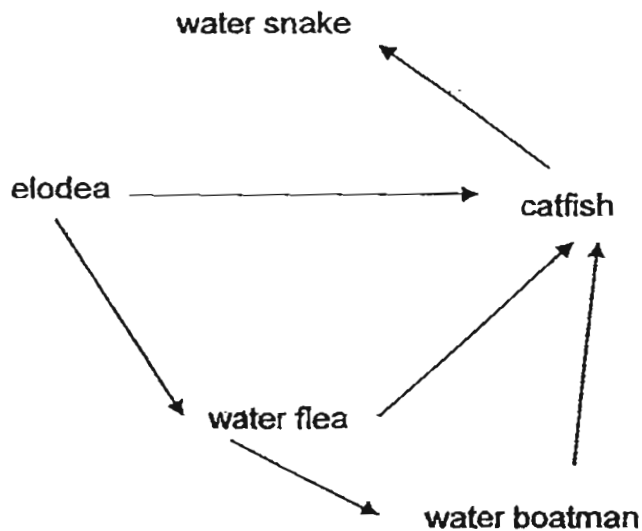

Which organisms are classified correctly as 'herbivores' and 'omnivores'?

	Herbivores	Omnivores
(1)	catfish	water snake
(2)	water flea	water boatman
(3)	water flea	catfish
(4)	water boatman	water snake

15. The diagram below shows a food web.

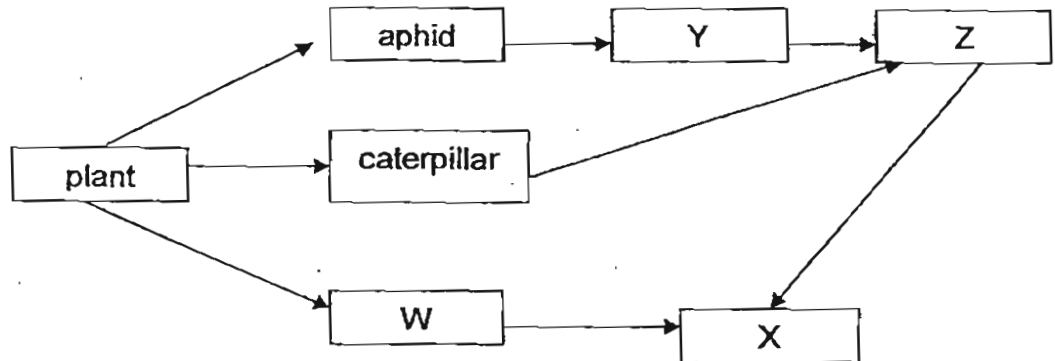

Choose the set of organisms from the following table that can be correctly used to complete the food web.

	W	X	Y	Z
(1)	earthworm	spider	sparrow	frog
(2)	rabbit	eagle	ladybug	sparrow
(3)	grasshopper	rabbit	lizard	eagle
(4)	squirrel	earthworm	lizard	frog

16. Which of the following adaptations enable the camel to live in the desert?

- A: It has small ears to get rid of excess body heat.  
 B: It urinates very little so as to lose as little water as possible.  
 C: It has long eyelashes to prevent sand from entering its eyes.  
 D: The humps of the camel store water to help it survive the high temperatures.

- (1) A and B only                      (2) B and C only  
 (3) C and D only                    (4) A, B and C only

17. Mary collected water samples from a pond. She placed 20 duckweeds into the sample of water. Mary observed the duckweeds for 5 days. She recorded her observations in the table below.

Original number of duckweeds	Number of duckweeds alive on the fifth day
20	7

Which could be the most possible reason for her above observation?

- (1) The pond is polluted with litter.  
 (2) The pond is polluted by oil spill.  
 (3) The pond is polluted by chemicals.  
 (4) The pond is polluted by soil erosion.

18. The diagram below shows a fruit.



Jian Wei carried out the following and made his observations as shown below.

- A: The fruit sunk when he placed it in a bowl of water.
- B: When he threw the fruit into the air, it dropped immediately.
- C: After he placed the fruit on his socks, it remained there firmly.

Which of the above can help Jian Wei to deduce that the fruit is dispersed in the same way as the mimosa?

- (1) A only
- (2) C only
- (3) B and C only
- (4) A, B and C

19. Which of the following statements correctly describes the structural and behavioural adaptations of some organisms?

	Structural adaptation	Behavioural adaptation
(1)	lays eggs in corners to increase the chances of survival	lays many eggs to increase the chances of survival
(2)	moves slowly to avoid predators	coils up to avoid predators
(3)	uses big eyes to hunt in darkness	uses big ears to hunt in darkness
(4)	uses stripes on its body to blend in with its surroundings	uses twigs to decorate its shell to blend in its surroundings

20. The graph below shows the relationship between the amount of pesticide and the number of strawberries harvested.

Number of strawberries harvested

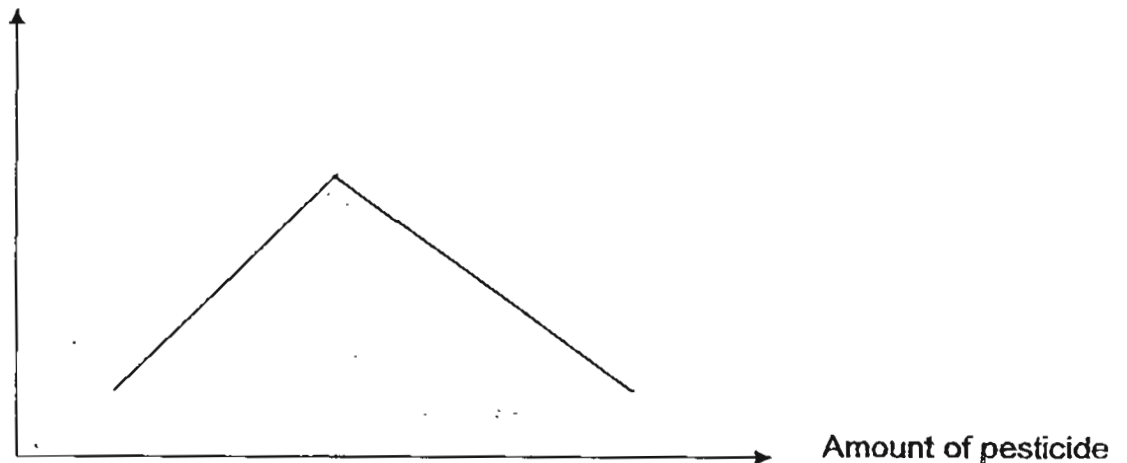

Based on the graph, which one of the following statements is true?

- (1) The number of strawberries harvested decreases when less pesticide is used.
  - (2) The number of strawberries harvested increases when more pesticide is used.
  - (3) When too much pesticide is used, the number of strawberries harvested decreases.
  - (4) The amount of pesticide used has no effect on the number of strawberries harvested.
21. Joshua set up an electric circuit as shown below.

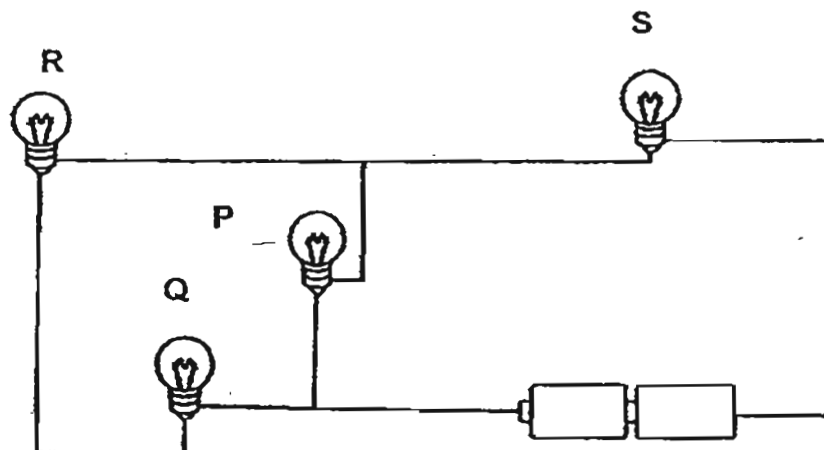

Which one of the following bulbs, P, Q, R or S, will cause all the other bulbs to go out when it fuses?

- (1) P
- (2) Q
- (3) R
- (4) S

22. Three pupils set up 2 closed circuits, S and T, to conduct an experiment. They recorded their observations in the table below.

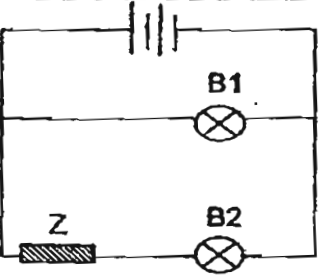
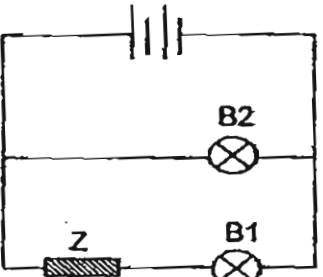
Set-up Circuits	Observations
 <p style="text-align: center;"><b>Circuit S</b></p>	<ul style="list-style-type: none"> <li>• B1 lit up</li> <li>• B2 did not light up</li> </ul>
 <p style="text-align: center;"><b>Circuit T</b></p>	<ul style="list-style-type: none"> <li>• B1 lit up</li> <li>• B2 did not light up</li> </ul>

Each of the pupils gave a reason to support their observations.

Aishah: The filament in bulb B2 had melted.

Basil: Z is a conductor of electricity.

Cedric: Z is a non-conductor of electricity.

Which of the following pupils was most likely accurate in his/her explanation?

(1) Aishah only

(2) Cedric only

(3) Aishah and Basil only

(4) Aishah and Cedric only

23. Cassie set up an experiment as shown below. When the circuit was closed, she observed that the nichrome wire was red hot.

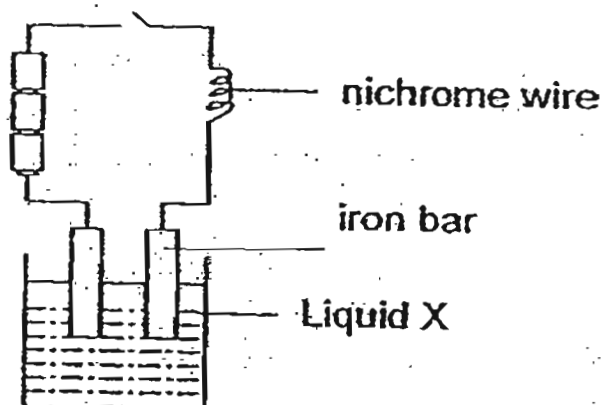

Which of the following statements are possible deductions that can be made from Cassie's experiment?

- A: Heat can pass through Liquid X.
- B: Electricity can pass through Liquid X.
- C: The greater the number of batteries in the circuit, the hotter the nichrome wire.
- D: The flowing electric current causes the nichrome wire to heat up greatly and glow.

- (1) A and C only
- (3) B, C and D only

- (2) B and D only
- (4) A, B, C and D

24. Study the electric circuits carefully. All batteries are brand new and of 1.5 volts. The bulbs are also of similar voltage.

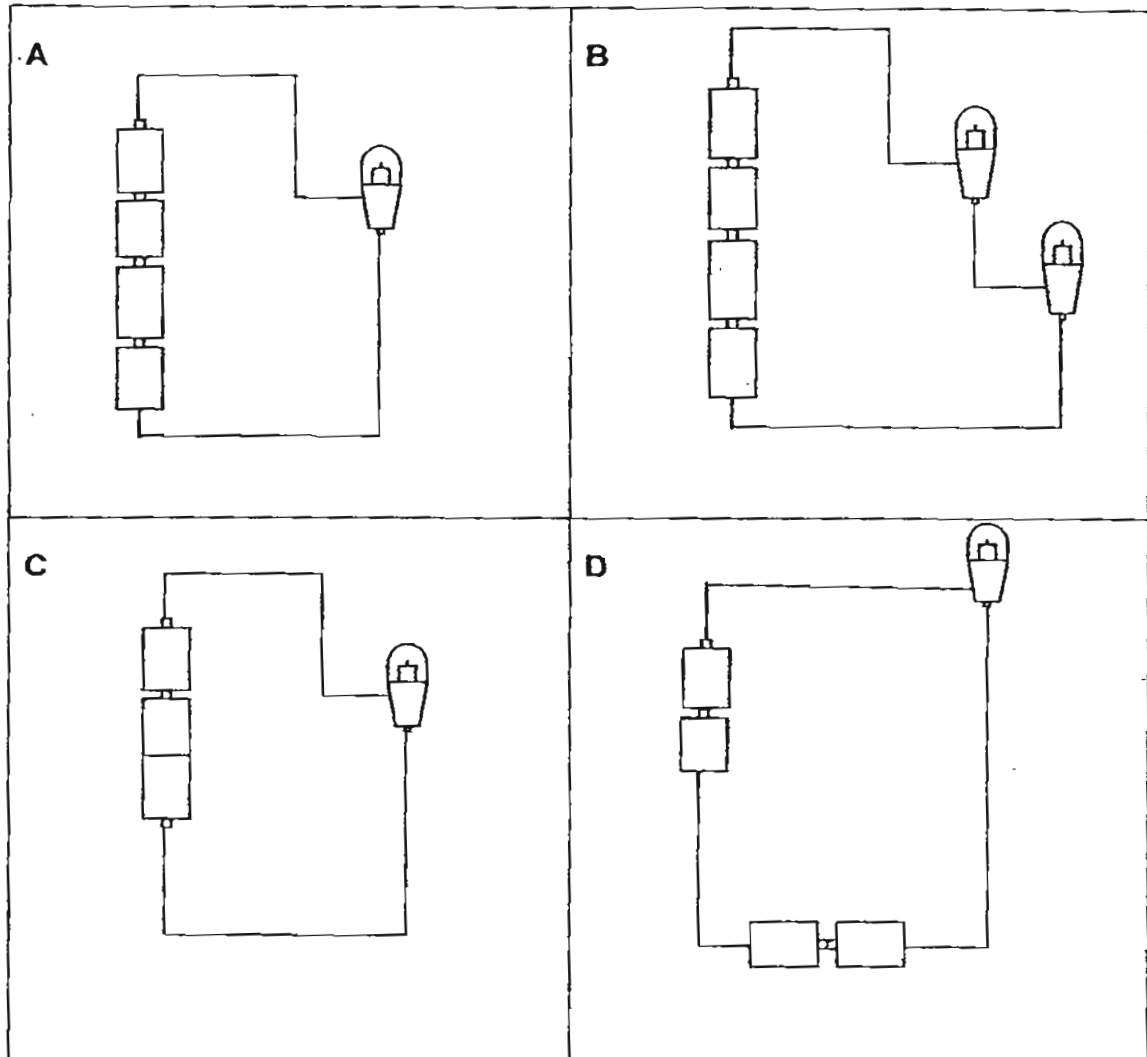

In which two set ups will the bulb be of the same brightness?

- (1) A and B only  
 (3) B and D only

- (2) A and D only  
 (4) C and D only



25. James set up four circuits, S, T U and V, using identical batteries and bulbs as shown in the diagrams below.

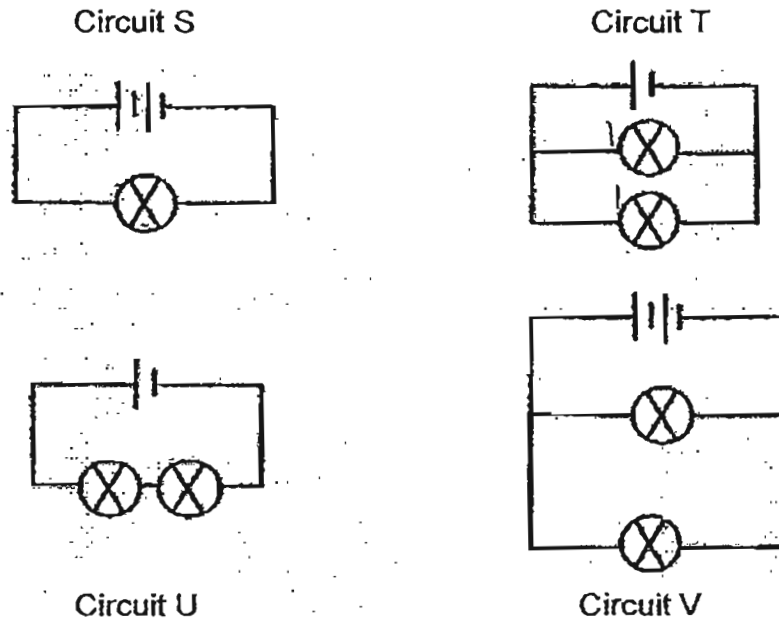

Which of the above circuits will have the same brightness?

- (1) S and T only  
 (2) S and V only  
 (3) T and U only  
 (4) T and V only
26. A ball is rolling in the direction of C. Where a force must be applied in order to make it move faster in the same direction?

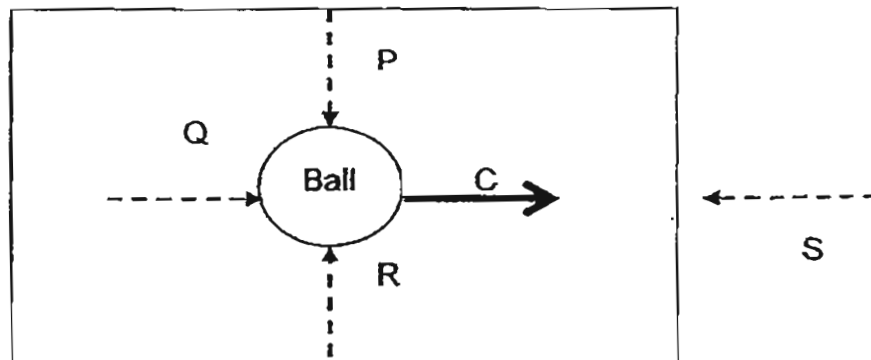

- (1) P  
 (2) Q  
 (3) R  
 (4) S

27. Bill used the same amount of force to move his toy car over four types of surfaces. He recorded the distance moved by his toy car in the table as shown below.

Type of surface	Distance moved by toy car(cm)
W	25
X	32
Y	12
Z	18

Arrange the four surfaces from the smoothest to the roughest.

- (1) W, X, Y, Z  
 (2) X, W, Y, Z  
 (3) Y, Z, W, X  
 (4) X, W, Z, Y
28. Peter placed Bar P and Bar Q in a container filled with thumbtacks at the same time. When he pulled out both bars, he observed that some thumbtacks were attached to Bar P but not Bar Q.

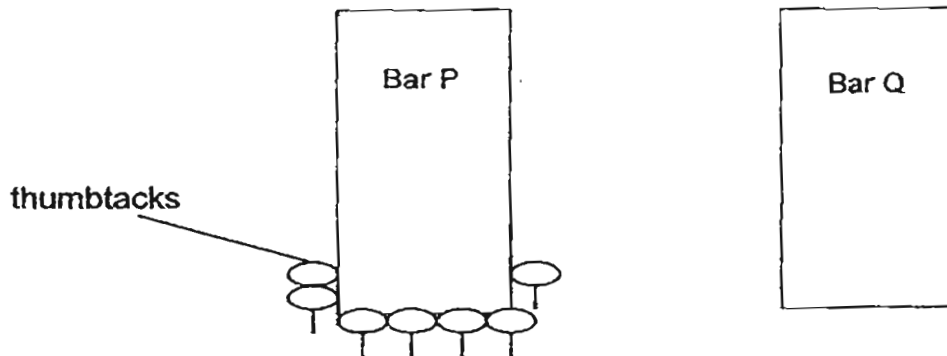

What can Peter deduce from his observation?

- A: Bar P is a magnet.  
 B: Bar Q is made of copper.  
 C: Bar P is made of a magnetic material.  
 D: Bar Q is a weaker magnet.
- (1) A only  
 (2) C only  
 (3) A and C only  
 (4) B and C only

~~C~~  
D

29. A plastic cube was pulled across three different surfaces as shown in the table below. The force needed to pull the plastic cube across each surface was measured and recorded.

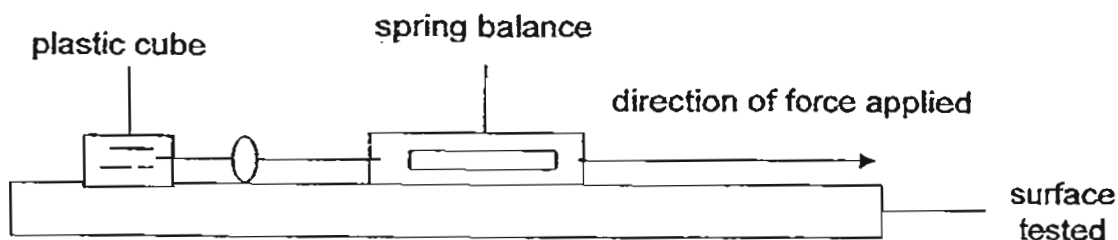

The results are shown in the table below.

Surface tested	Force needed to move the block in Newtons (N)
Surface A	12
Surface B	?
Surface C	18

The following observations were made:

- It was easier to move the plastic cube across Surface B than Surface C.
- It was more difficult to move the plastic cube across Surface B than Surface A.

How much force would have been needed to move the plastic cube across Surface B?

- (1) 16N  
(2) 20N  
(3) 24N  
(4) 28N
30. Tim had a toy robot which had a spring in it. He wanted to find out how he could make his wound-up robot move further. From the list of variables given below, which variable(s) should he keep the same to make his experiment a fair one?

<p>Variable A – Number of turns of the spring                  Variable B – Starting position of the toy robot                  Variable C – Distance moved by the toy robot                  Variable D – Surface on which the robot moves</p>
---

- (1) A only  
(2) D only  
(3) B and D only  
(4) B, C and D only

End of Booklet A



**Rosyth School**  
**Semestral Examination for 2011**  
**STANDARD SCIENCE**  
**Primary 5**

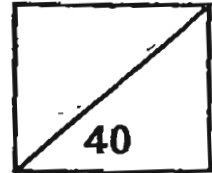

Name: \_\_\_\_\_

Total  
Marks:

Class: Pr \_\_\_\_\_

Register No. \_\_\_\_\_

Duration: 1 h 45 min

Date: 1 Nov 2011

Parent's Signature: \_\_\_\_\_

---

## **Booklet B**

Instructions to Pupils:

1. For questions 31 to 44, give your answers in the spaces given in this Booklet B.

\* This booklet consists of 18 pages.

This paper is not to be reproduced in part or whole without the permission of the Principal.

**PART II (40 MARKS)**

For questions 31 to 44, write your answers in this booklet. The number of marks available is shown in brackets at the end of each question or part question.

31. Study the 2 set-ups as shown below.

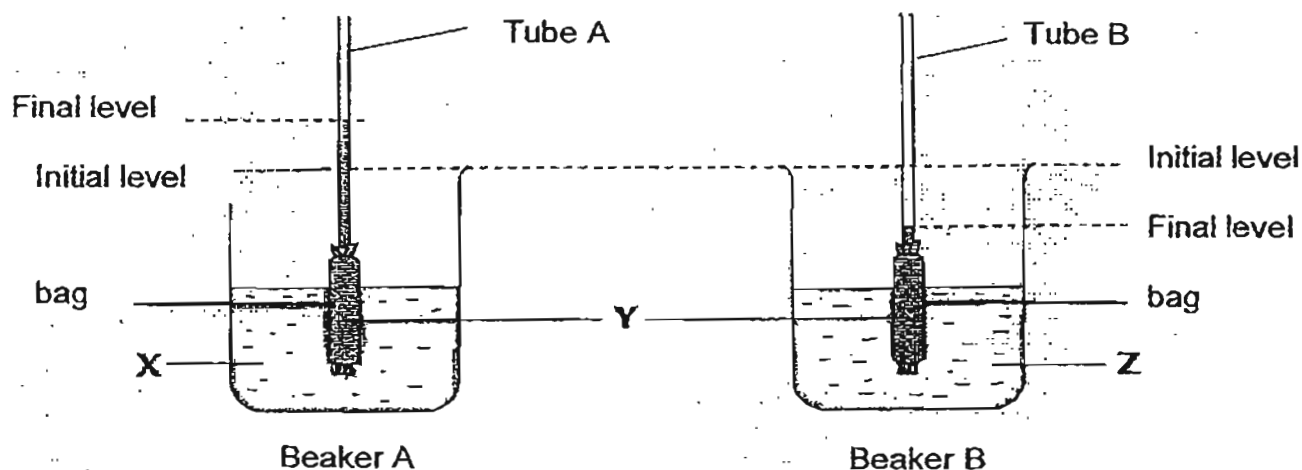

Two identical bags each containing liquid Y, were immersed in beakers A and B containing Liquids X and Z respectively. The bags were made of special material. At the beginning of the experiment, the initial levels of liquid Y in the two bags were the same. After an hour, it was observed that the level Y increased in tube A but decreased in tube B.

(a)(i) Explain why there was an increase in tube A. [1/2 m]

---

---

(ii) Explain why there was a decrease in tube B. [1/2 m]

---

---

(Question 31 is continued on Pg 2)

The set-up was then changed. Four different kinds of cells were then placed into Beaker A containing Liquid X.

The diagram below shows the 4 kinds of cells used.



Muscle cell

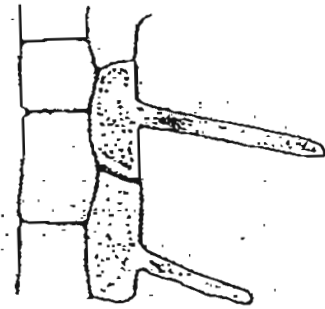

Root hair cell

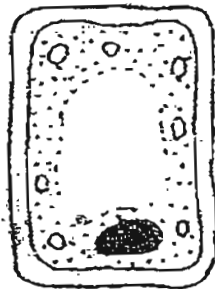

Leaf cell

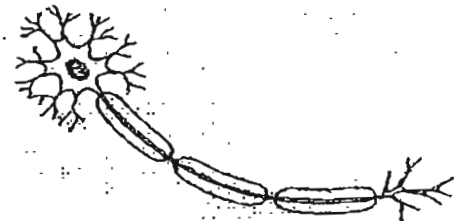

Nerve cell

It was observed that some of the cells expanded and burst in Liquid X.

(b) Identify the cells that would have burst and explain why. [2m]

---

---

---

32. Tommy collected a sample of pondwater and examined a few drops of it under a microscope. He observed and drew the diagram of a single-celled organism, Organism X, as shown below. He noticed that Organism X moves about using its tail-like structures called flagella.

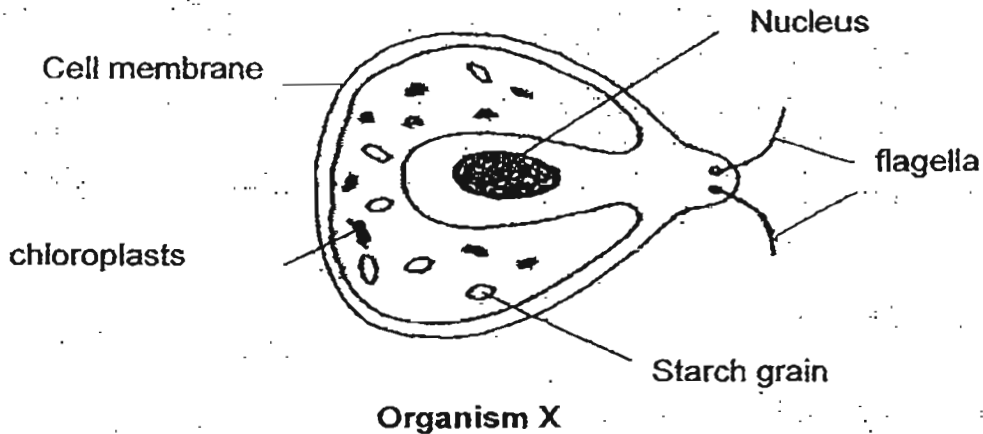

Based on the diagram, explain why Tommy would have difficulty in classifying Organism X as an animal or plant cell. [2m]

- (i) Reason for X not being classified as an animal cell:

---

---

- (ii) Reason for X not being classified as a plant cell:

---

---

33. Siti set up an experiment using a white carnation as shown below.

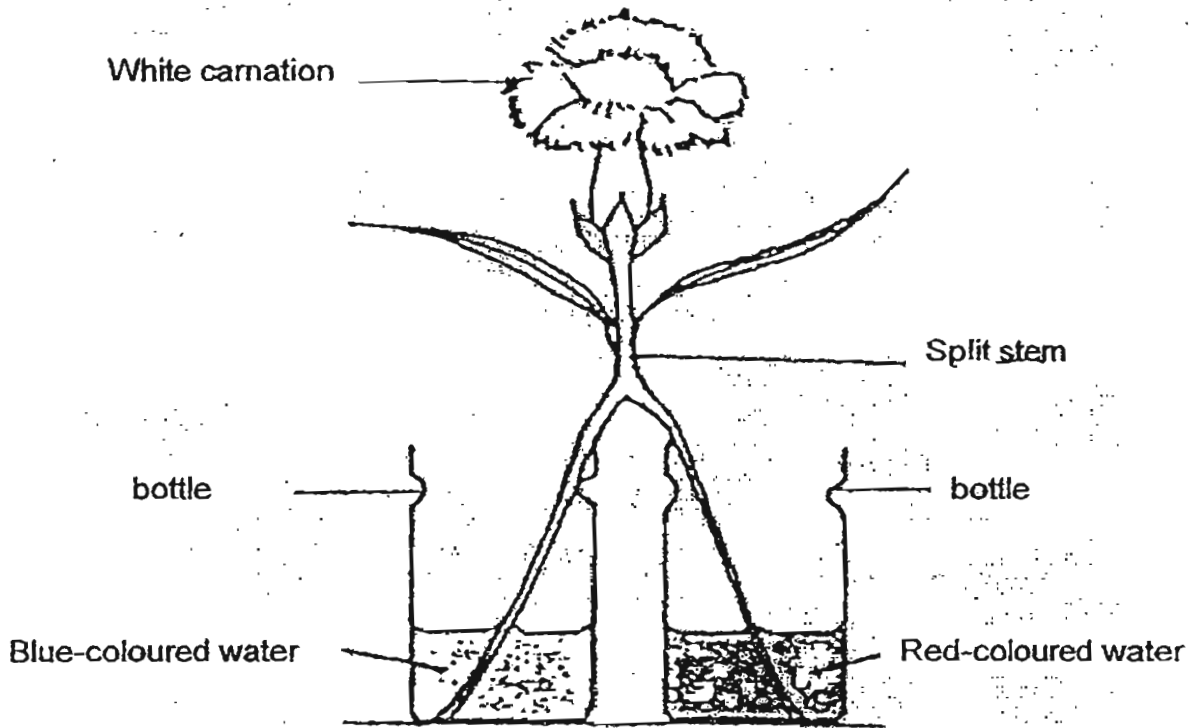

She observed that there were red and blue coloured specks on the flower.

(a) What could you deduce from the above observations? [1m]

---

---

(b) She also noticed that the water level in the two bottles had decrease after a few days.  
Give two likely reasons that could have caused the decrease in water level. [2m]

(i) \_\_\_\_\_  
\_\_\_\_\_

(ii) \_\_\_\_\_  
\_\_\_\_\_



34. Jake wanted to find out if living things give out carbon dioxide when breathing. He used the set-up as shown below. He found that limewater turns chalky in the presence of carbon dioxide.

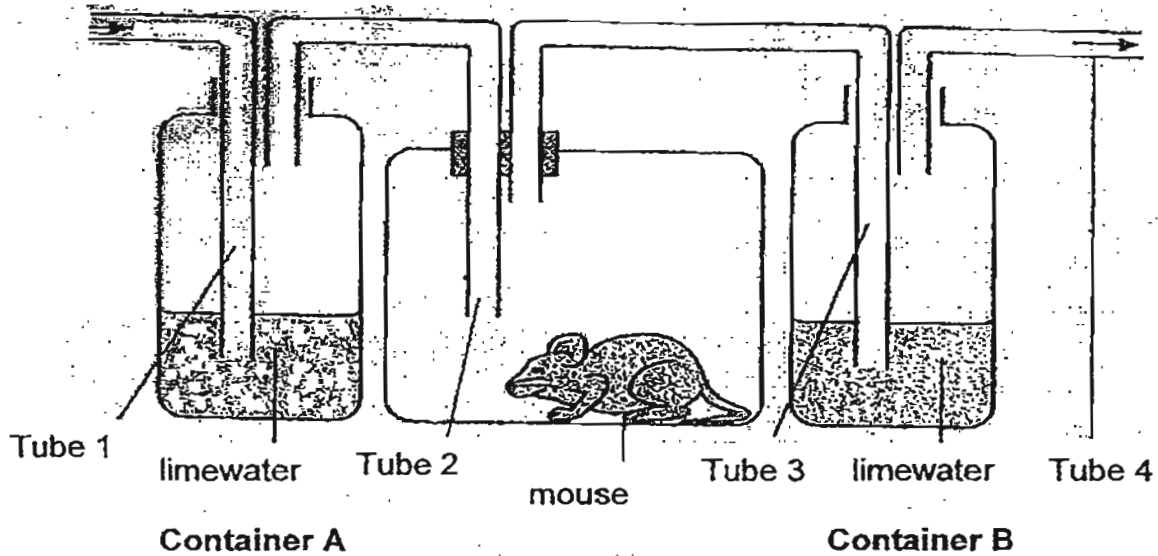

- (a) He observed that the limewater in container B was more chalky than that in container A. Give a reason for this observation. [1m]

---

---

(Question 34 is continued on Pg 6)

He then decided to experiment with a simplified set-up as shown below.

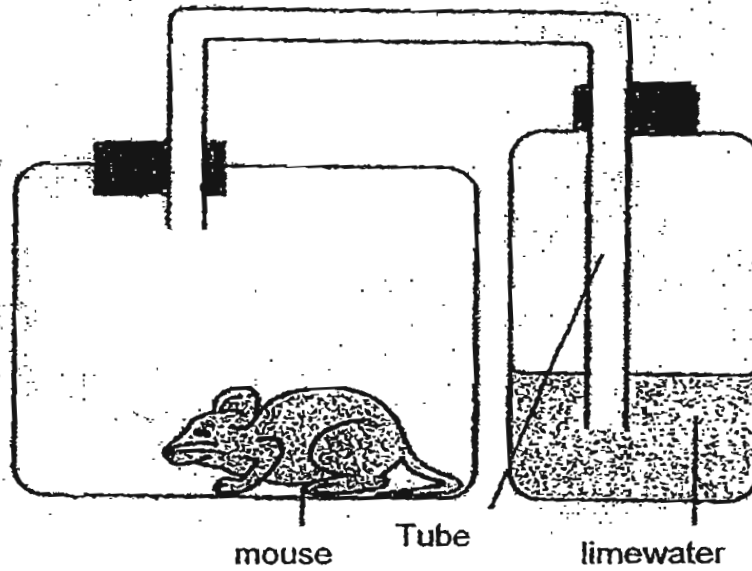

(b) Draw and label the control set-up for this experiment. [1m]

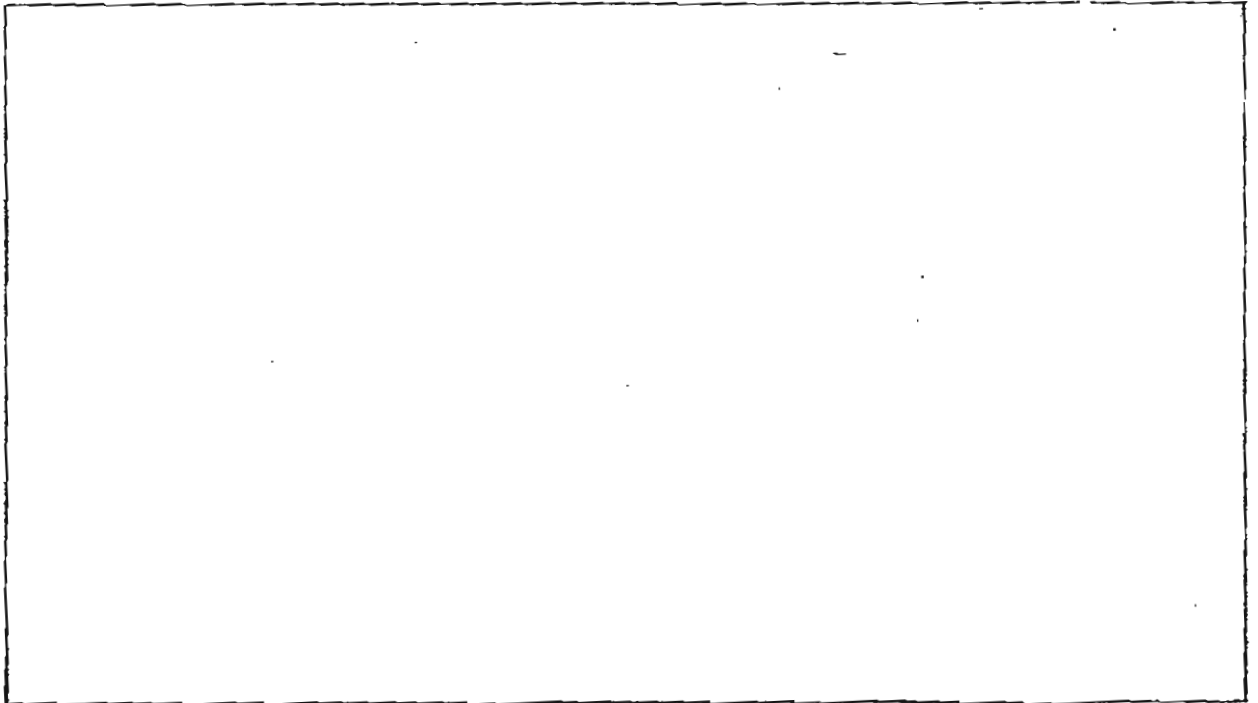

(c) What is the purpose of the control? [1m]

---

---

---

35. The diagram below shows the head of a fish.

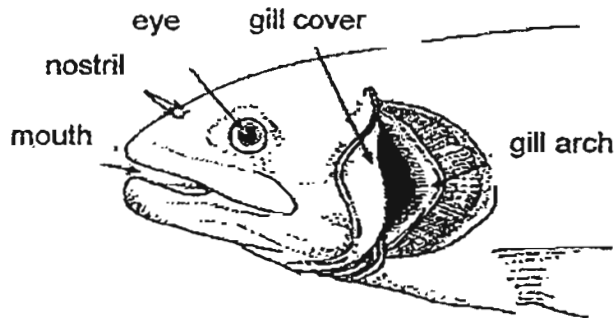

The cross section of the fish head is shown below to reveal the position of the gills and gill cover.

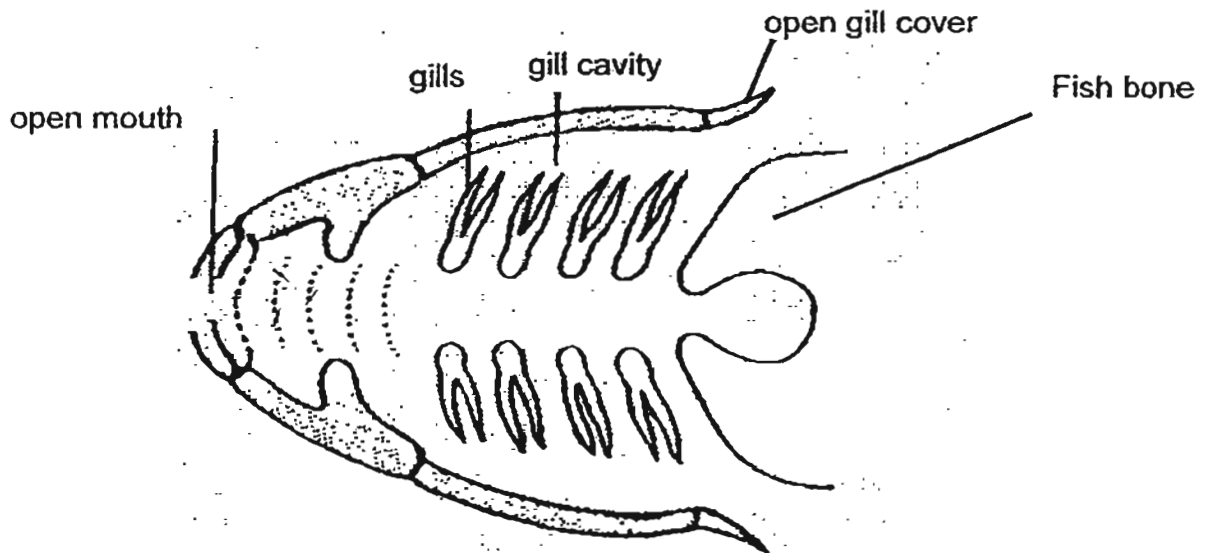

(a) Draw arrows on the diagram above to show the correct passage for the flow of water when a fish takes in oxygen and gives out carbon dioxide. [1m]

(b) State two differences in the way gaseous exchange occurs in fish and Man. [2m]

(i) \_\_\_\_\_

\_\_\_\_\_

\_\_\_\_\_

(ii) \_\_\_\_\_

\_\_\_\_\_

\_\_\_\_\_

36. Joe planted 3 types of vegetables – X, Y and Z on three plots of land as he wanted to conduct an experiment. He introduced some snails on all the plots of land. All the plots of land received the same amount of sunlight, water and nutrients. He observed the number of vegetables left after the snails were introduced. He recorded his results in the table shown below.

Plot of land	Type of vegetable	Number of vegetables at the start of the experiment	Number of vegetables at the end of the experiment
A	X	40	28
B	Y	40	15
C	Z	40	40

- (a) From the results shown in the table, which vegetable did the snails like the most? [1m]

---

After some time, Joe introduced Organism K to plot A. Organism K is a predator of snails.

- (b) Describe the impact Organism K would have on the organisms in plot A. [1m]

37. Raj prepared two fish tanks as shown below. He placed both set-ups near an open window and fed the fish daily with the same amount of food.

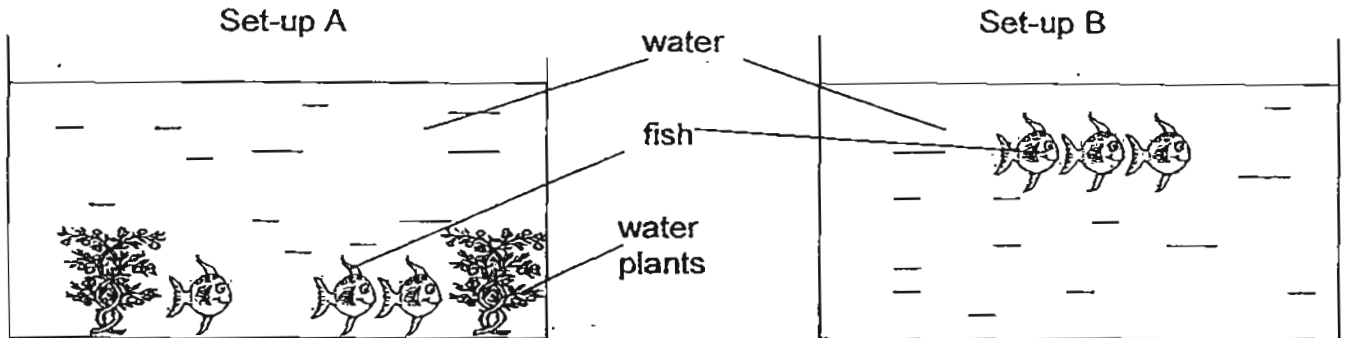

- (a) State the variable that has been changed in the above set-ups. [1m]

---

Raj observed that the fish in Set-up B swam close to the surface of the water while the fish in Set-up A did not do so.

- (b) Why do you think the fish in Set-up B behaved in such a manner? Explain your answer. [2m]

---

---

---

---

38. Study the following food chains carefully. They show the food relationships of some organisms living in the same habitat.

Food Chain 1

plant → praying mantis → sparrow → eagle

Food Chain 2

plant → praying mantis → frog → snake → eagle

Food Chain 3

plant → praying mantis → frog → eagle

Construct a food web in the box below based on the above three food chains. [2m]



39. Study the food web shown below.

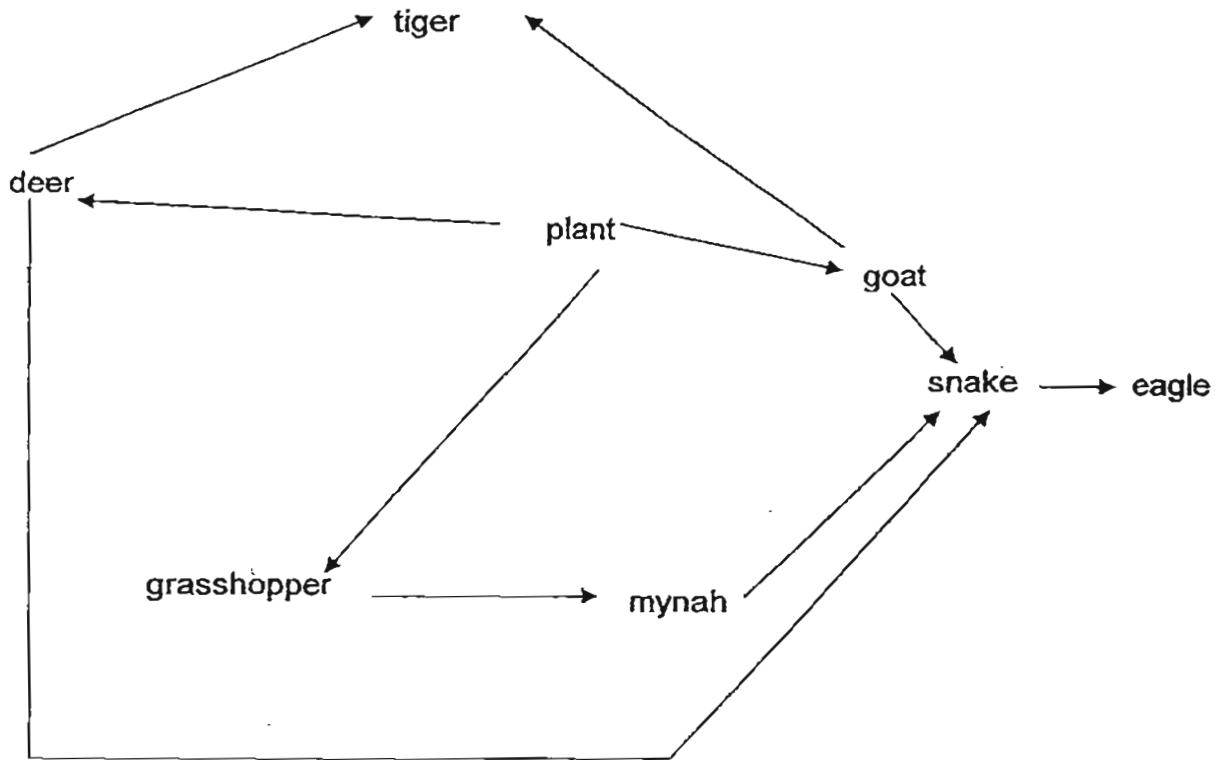

(a) Identify two organisms that are both a prey and a predator. [2m]

---

(b) What would happen to the grasshopper population when all the snakes are killed? Explain your answer. [2m]

---

---

---

40. Farmer John discovered a population of harmful Insect P on his farm. In February he sprayed a chemical on his crops. The graph below shows the population size of Insect P before and after the chemical was sprayed.

Population of insect P

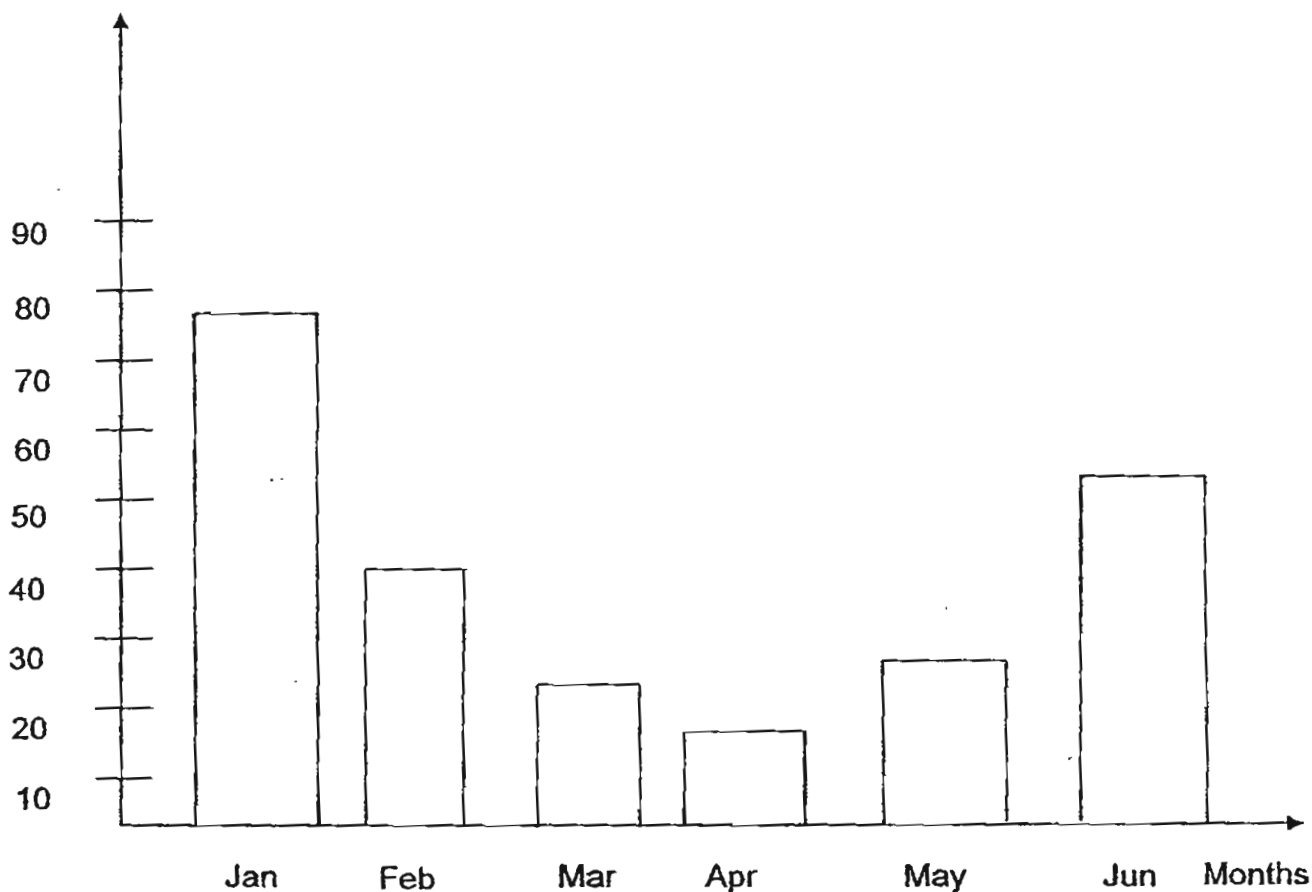

- (a) What was the effect of the chemical on the population of Insect P from February to April? [1m]
- 
- (b) Based on the graph the population of Insect P started increasing from May. State a likely cause for this increase. [1m]
- 
-



41. Sarah set up an electric circuit to test if the materials, J, K, L, M and N, will conduct electricity. She recorded the results in the table below.

Material	J	K	L	M	N
Did the bulb light up in the circuit	No	Yes	No	Yes	Yes

Complete the classification chart below to classify the materials into two groups based on their conductivity of electricity.

Provide the headings for the boxes (i) and (ii) and state the materials using the given letters from the table [2m]

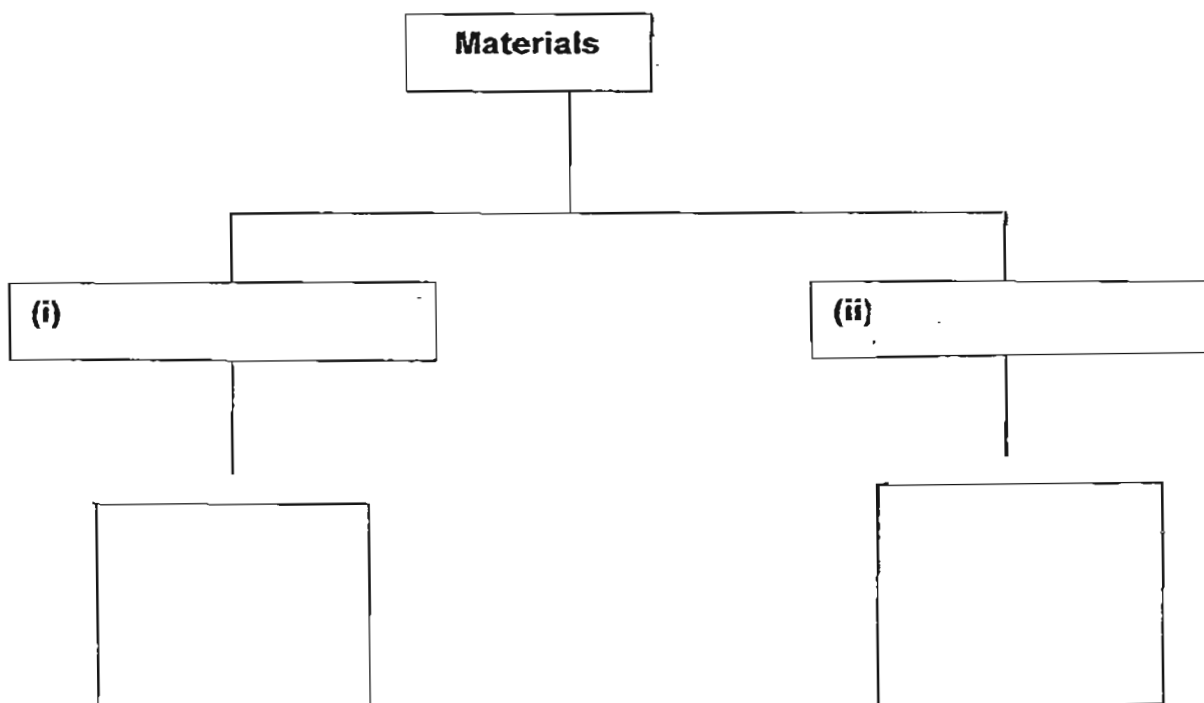

42. Jason used identical batteries and light bulbs in two different electrical circuits. He set up the two circuits, A and B, using the same number of batteries. As he added on more bulbs to the circuits, he observed the brightness of the light bulbs. He then plotted a graph to compare the brightness of the bulbs in the two circuits.

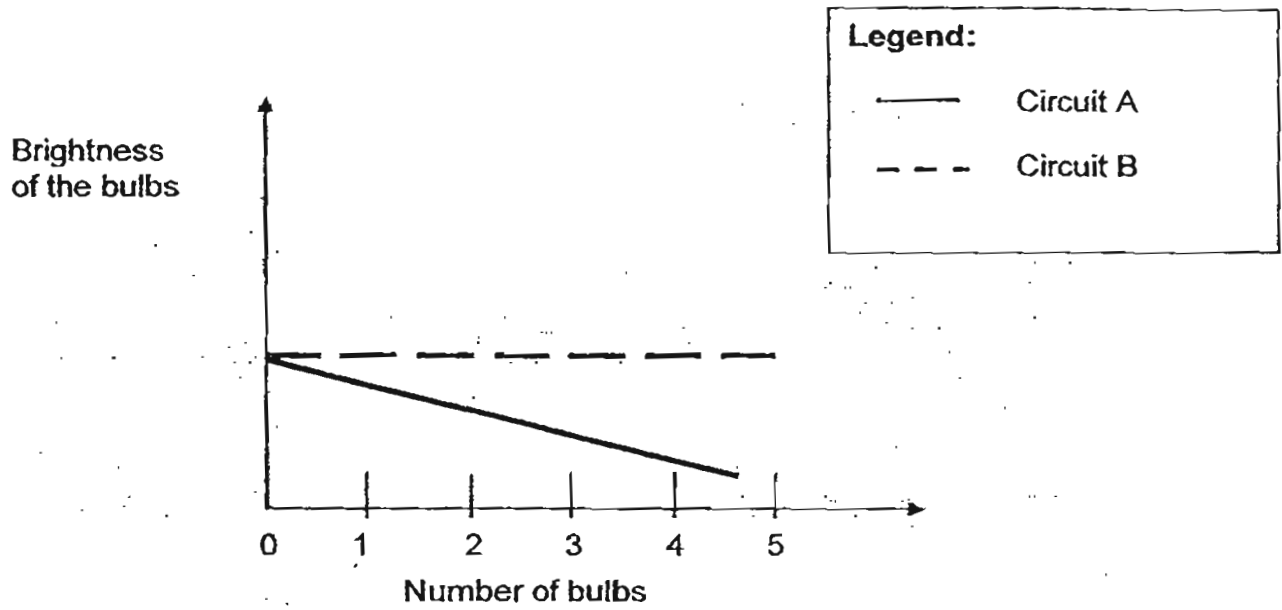

- (a) Based on the graph, draw the circuit diagrams to represent the circuits A and B. Use 3 bulbs in each of the circuits [2m]

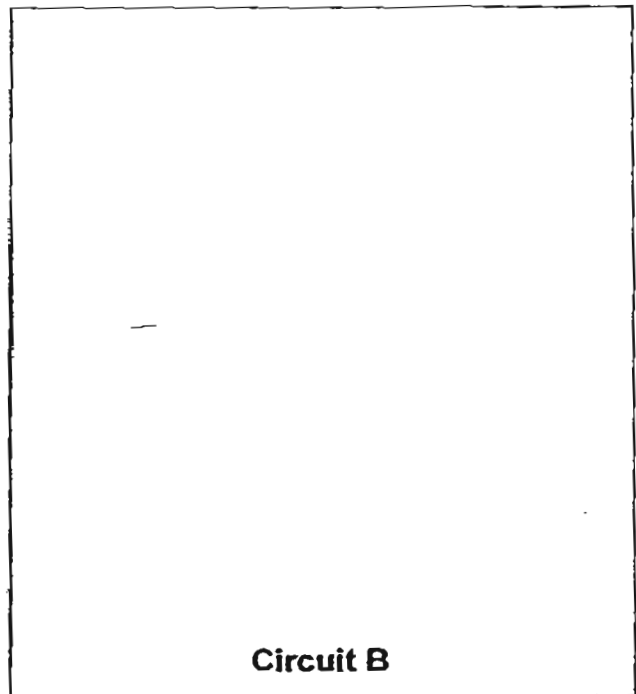
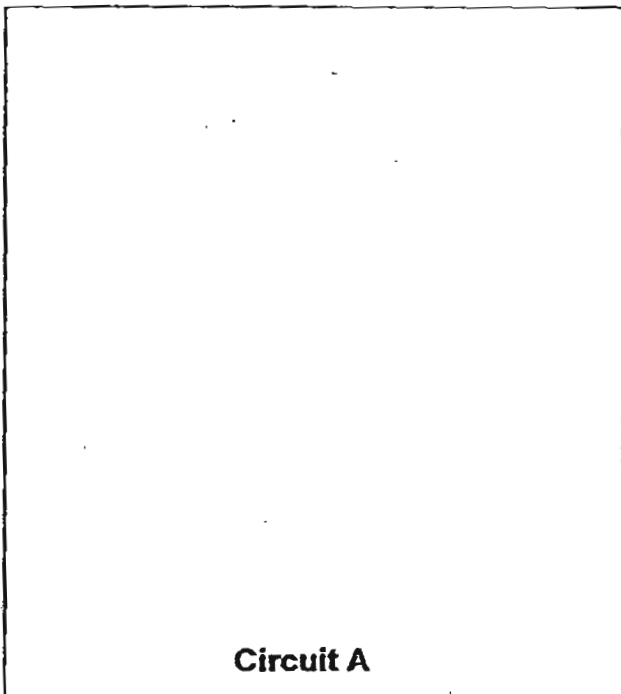

(Question 42 is continued on Pg 15)

(b) Jason prefers to use Circuit B in his home, Explain why? [1m]

---

---

(c) Suggest a way to improve the circuit B to save electricity in his home. [1m]

---

---

43. Kate was trying to find out how the different amounts of load hung on a spring affected its length. She hung loads with different masses on a spring. She also measured the respective length of the spring each time she hung a load. She then recorded her findings and plotted the graph shown below.

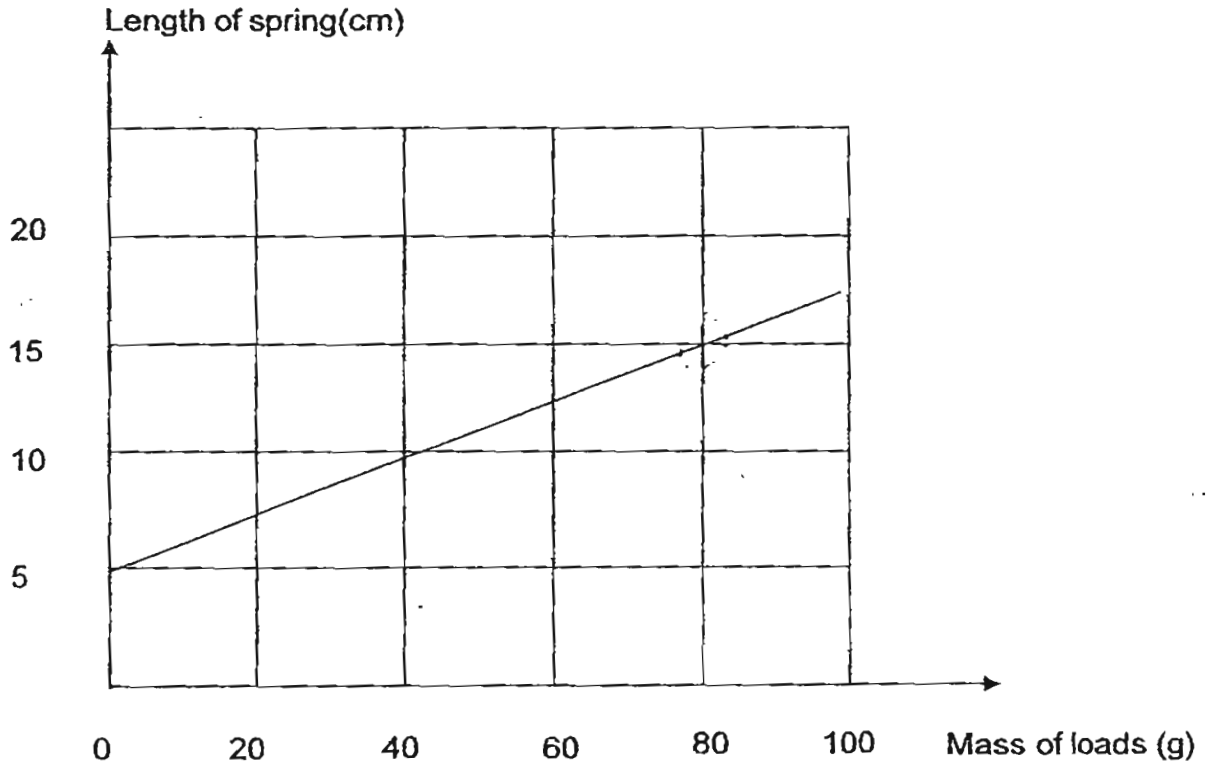

- (a) From the graph, what will the extension of the spring be if a 80g load is hung on the spring? [1m]

---

- (b) What is the relationship between the length of the spring balance and the weights hung on it? [1m]

---



---

- (c) Why did the spring stretch when the load was added? [1m]

---



---

44. Bala wanted to find the bounce height of three different balls when they are dropped from the same height. He recorded his findings in the table shown below.

Type of ball	1 <sup>st</sup> try (cm)	2 <sup>nd</sup> try (cm)	3 <sup>rd</sup> try (cm)	Average height(cm)
Netball	80	85	75	80
Squash ball	90	95	85	90
Table-tennis ball	15	20	25	20

- (a) Based on the table, draw and label a bar graph showing the results Bala had obtained. [2m]

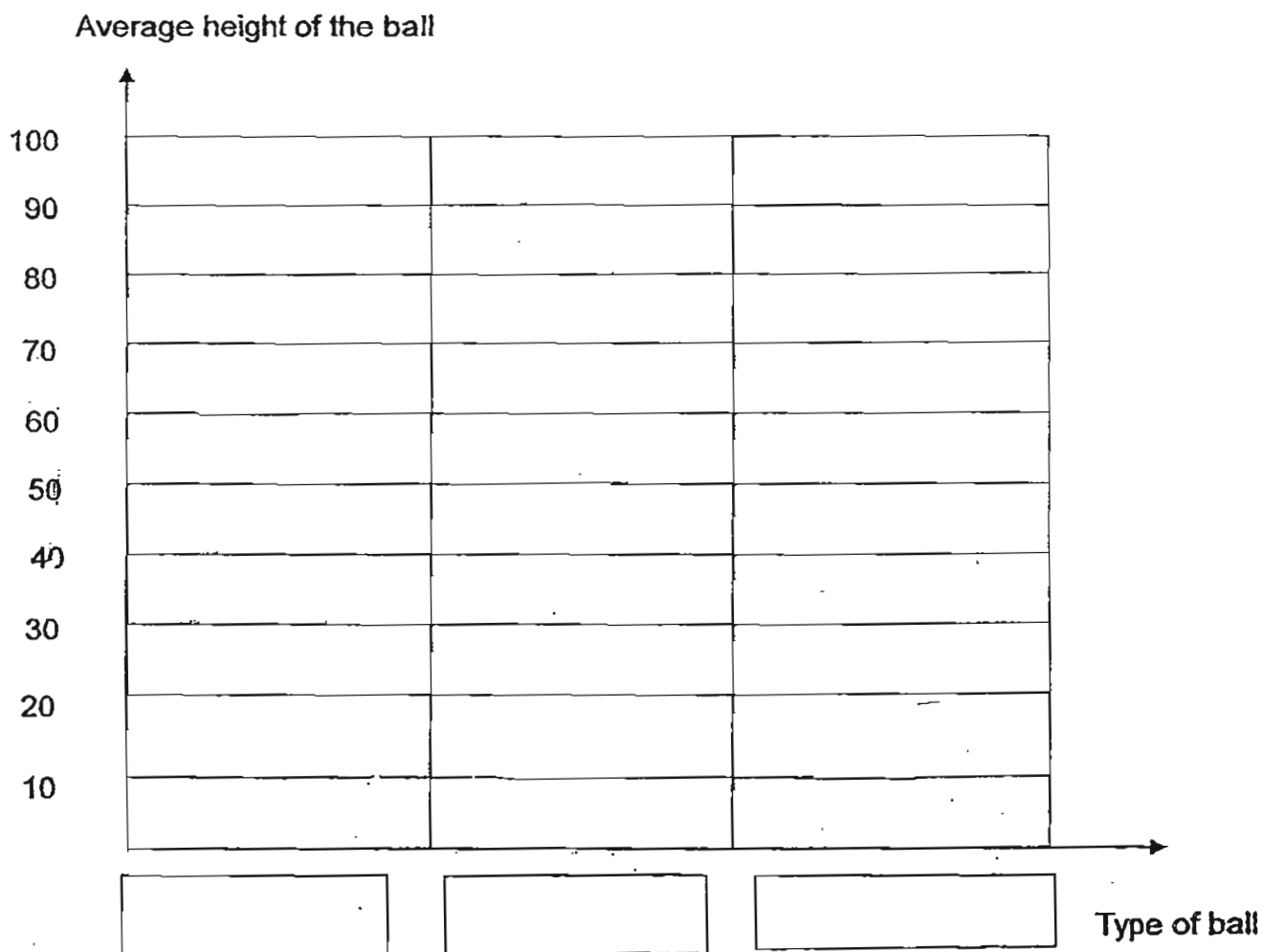

(Question 44 is continued on Pg 18)

- (b) What is the purpose of Bala conducting the experiment three times?  
[1m]

---

---

- (c) What forces acted on the balls as they bounced up? [1m]

---

---

**End of the paper**

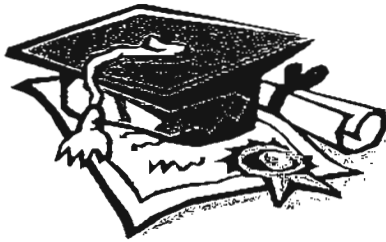

# ANSWER SHEET

**EXAM PAPER 2011**

**SCHOOL : ROSYTH  
SUBJECT : PRIMARY 5 SCIENCE**

**TERM : SA2**

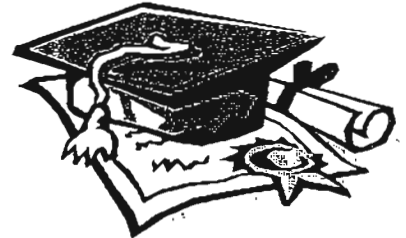

Q1	Q2	Q3	Q4	Q5	Q6	Q7	Q8	Q9	Q10	Q11	Q12	Q13	Q14	Q15	Q16	Q17
1	2	3	2	1	3	3	1	2	3	3	4	3	3	2	2	3

Q18	Q19	Q20	Q21	Q22	Q23	Q24	Q25	Q26	Q27	Q28	Q29	Q30
2	4	3	4	3	2	3	2	2	4	3	1	3

- 31)a)i)Liquid X entered the bag, causing the level of Y in tube A to increase.  
ii)Liquid Y exit the bag, causing the level of Y in tube B to decrease.  
b)Muscle cell and nerve cell. They do not have a cell wall which prevent the cell from bursting.

- 32)i)Organism X has chloroplasts which only plant cells have.  
ii)Organism, X does not have a cell wall, which plant cells have.

- 33)a)There is more than one xylem tube to transport water.  
b)i)The stem absorb the water and the xylem transported it to the rest of the plant.  
ii)The water from the bottles evaporated into the surrounding air.

- 34)a)More carbon dioxide is exhaled from the mouse compared to the carbon dioxide from the surrounding air.  
b)

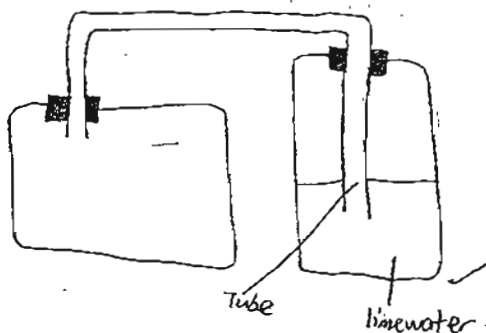

- c)It is to prove that the mouse exhales carbon dioxide .

35)a)

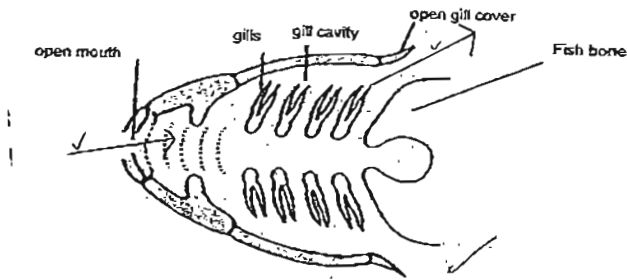

b)i) Fish take in dissolved oxygen while Man take in oxygen from the air.

ii) In a fish, gaseous exchange takes place in the gills while in Man, gaseous exchange takes place in the lungs.

36)a) Vegetable Y.

b) Organism K would prey on the snails causing them to decrease in numbers, so the population of vegetable X in plot A will increase as there would be less consumers to consume it.

37)a) Presence of water plants.

b) The fish in Set-up B wanted to obtain more oxygen from near the surface of the water. As there are no water plants to replenish the supply of oxygen in Set-up B, the fishes in it will have less oxygen and thus swim closer to the surface of the water to try and obtain more oxygen.

38)

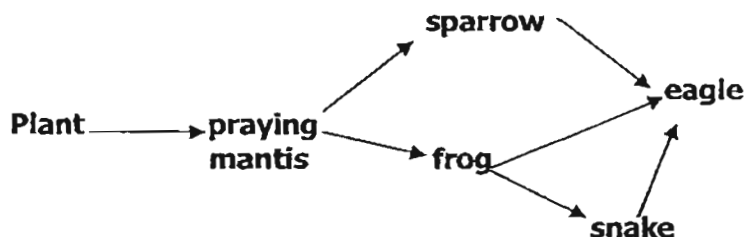

39)a) Mynah and snake.

b) The grasshopper population would decrease. The snake preys on the mynahs, which preys on the grasshoppers. Hence, when all the snakes are killed, there will be no more animals preying on the mynahs, causing it to increase, which will lead to the population of grasshoppers decreasing as there would be more mynahs preying on them.

40)a) The population of insect P decreased.

b) Insect P has adapted to living with the chemical.

41)i) Conductors of electricity

K,M,N

ii) Non-conductors of electricity

J,L



42)a)

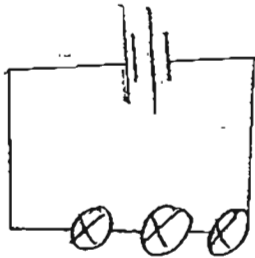

Circuit A

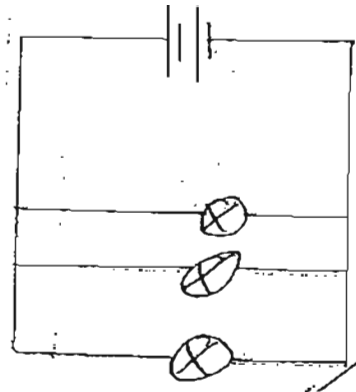

Circuit B

b) When one bulb is fused the rest can still work.

c) Add a switch.

43)a) 10cm.

b) The heavier the weights, the longer the length of the spring balance.

c) The weight of the load acted on the spring and stretched it.

44)a)

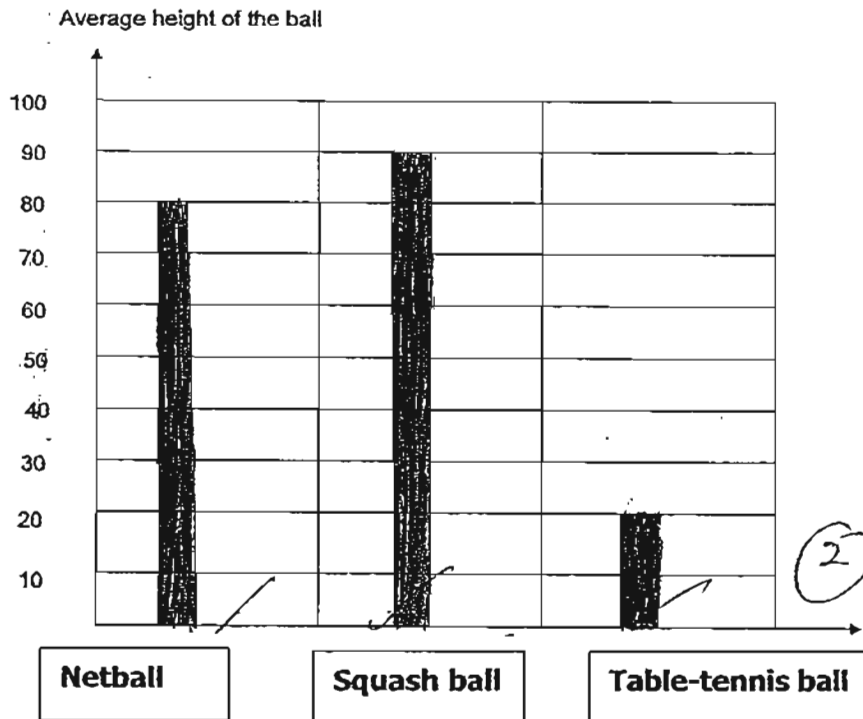

b) To ensure that the result were reliable.

c) Gravitational force and frictional force.