



HENRY PARK PRIMARY SCHOOL  
2016 SEMESTRAL EXAMINATION 2  
MATHEMATICS  
PRIMARY 5

PAPER 1  
(BOOKLET A)

Name: \_\_\_\_\_ (     )

Parent's Signature

Class: Primary 5 \_\_\_\_\_

\_\_\_\_\_

Marks:

Paper 1	Booklet A	20
	Booklet B	20
Paper 2		60
<b>Total</b>		<b>100</b>

Total Time for Booklets A and B: 50 min

Do not turn over this page until you are told to do so.

Follow all instructions carefully.

Answer all questions.

Shade your answers in the Optical Answer Sheet (OAS) provided.

You are **not** allowed to use a calculator.

Booklet A:

Questions 1 to 10 carry 1 mark each. Questions 11 to 15 carry 2 marks each.  
For each of the questions, four options are given. One of them is the correct answer.  
Choose the correct answer (1, 2, 3 or 4). Shade the correct oval on the Optical Answer Sheet provided.

(20 marks)

1. Singapore attracted 231 469 tourists from a particular country last year. Express this number to the nearest thousand.  
  - (1) 200 000
  - (2) 230 000
  - (3) 231 000
  - (4) 232 000
  
2. How many tens make 780 000?  
  - (1) 78
  - (2) 780
  - (3) 7 800
  - (4) 78 000
  
3. What is the sum of 12 l 50 ml and 1 l 8 ml?  
  - (1) 13.058 l
  - (2) 13.130 l
  - (3) 13.300 l
  - (4) 13.580 l

(Go on to the next page)

4. The figure below shows a man standing next to a table. Which of the following could be the height of the table?

- (1) 8 cm
- (2) 80 cm
- (3) 800 cm
- (4) 8000 cm

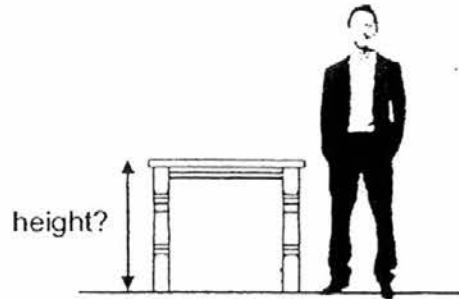

5. Which of the following has the same value as  $\frac{2}{5} \div 3$  ?

(1)  $\frac{2}{5} \times \frac{1}{3}$

(2)  $\frac{2}{5} \times \frac{3}{1}$

(3)  $\frac{5}{2} \times \frac{1}{3}$

(4)  $\frac{5}{2} \times \frac{3}{1}$

6.  $66 - 30 \div 3 - 8 - 2 = \boxed{?}$   
What is the missing number in the box?

- (1) 6
- (2) 2
- (3) 46
- (4) 50

(Go on to the next page)

7. What is the value of 3 hundreds + 4 tens + 17 tenths?

- (1) 350.7
- (2) 341.7
- (3) 340.17
- (4) 304.17

8. Which one of the following shapes has more than one line of symmetry?

(1)



(2)

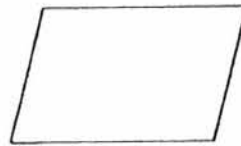

(3)

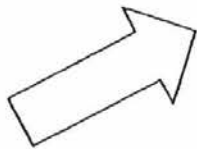

(4)



9. The ratio of the length of a rectangle to its breadth is 5 : 3.  
The perimeter of the rectangle is 32 cm.  
What is the length of the rectangle?

- (1) 6 cm
- (2) 10 cm
- (3) 12 cm
- (4) 20 cm

(Go on to the next page)

10. Express 0.7 as a percentage.

- (1) 0.7%
- (2) 7%
- (3) 70%
- (4) 700%

11. Express  $2\frac{3}{25}$  as a decimal.

- (1) 2.12
- (2) 2.15
- (3) 2.3
- (4) 2.6

12. The figure below is made up of a rhombus ABCD and a trapezium BEFC. DCF is a straight line and  $\angle BDC = 41^\circ$ . Find  $\angle p$ .

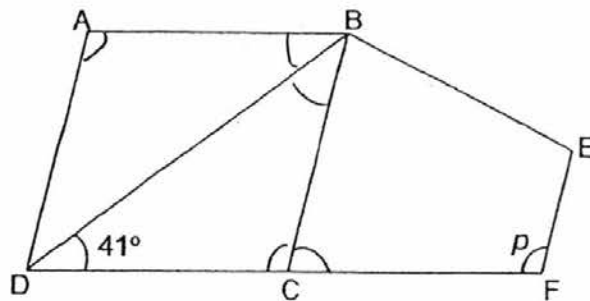

- (1)  $82^\circ$
- (2)  $98^\circ$
- (3)  $108^\circ$
- (4)  $139^\circ$

(Go on to the next page)

13.  $15 : 12 = 40 : \boxed{?}$   
What is the missing number in the box?
- (1) 37
  - (2) 32
  - (3) 8
  - (4) 4
14. What is the maximum number of 3-cm cubes that Matthias can cut from a styrofoam cuboid that measures 18 cm by 12 cm by 10 cm?
- (1) 13
  - (2) 72
  - (3) 80
  - (4) 240
15. After spending  $\frac{3}{7}$  of her money on a handbag, Mrs Ng had \$384 left.  
How much money did she have at first?
- (1) \$288
  - (2) \$512
  - (3) \$672
  - (4) \$896

(Go on to Booklet B)



HENRY PARK PRIMARY SCHOOL  
2016 SEMESTRAL EXAMINATION 2  
MATHEMATICS  
PRIMARY 5

PAPER 1  
(BOOKLET B)

Name: \_\_\_\_\_ ( )

Class: Primary 5 \_\_\_\_\_

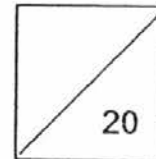

Total Time for Booklets A and B: 50 min

Do not turn over this page until you are told to do so.

Follow all instructions carefully.

Answer all questions.

Write your answers in this booklet.

You are **not** allowed to use a calculator.

Booklet B:

Questions 16 to 25 carry 1 mark each. Write your answers in the spaces provided.  
For questions which require units, give your answers in the units stated.

(10 marks)

16. Divide 14 040 by 20.

Do not write  
in this space

Ans: \_\_\_\_\_

17. In the figure below, given that AD is the height of the triangle ABC, what is its base?

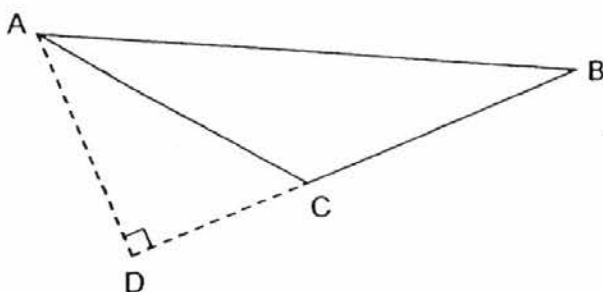

Ans: \_\_\_\_\_

18. Express 11 m 2 cm in metres. Give your answer as a decimal.

Ans: \_\_\_\_\_ m

(Go on to the next page)

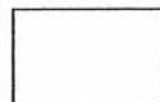



19. Find the value of  $4.037 \times 300$

Do not write  
in this space

Ans: \_\_\_\_\_

20. Divide 1365 by 9. Round off your answer to 2 decimal places.

Ans: \_\_\_\_\_

21. In the figure below, MN and PQ are straight lines. Find  $\angle x$ .

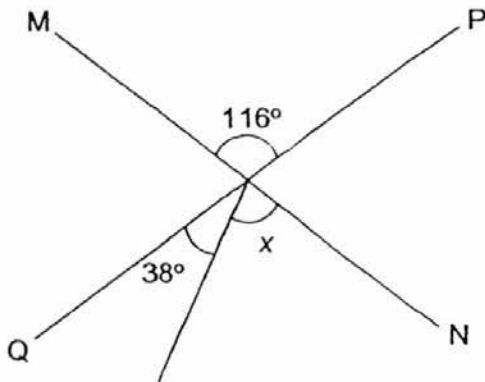

Ans: \_\_\_\_\_<sup>o</sup>

(Go on to the next page)

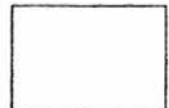

22. In the figure below,  $WXZ$  is an equilateral triangle and  $WZY$  is a straight line.  $\angle YXZ = 34^\circ$ . Find  $\angle WYX$ .

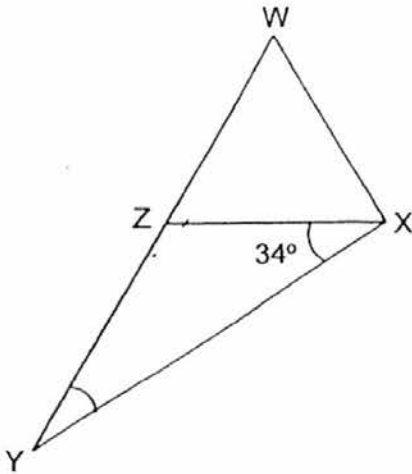

Ans: \_\_\_\_\_ $^\circ$

23. Jane has 4 different pieces of string measuring 20 cm, 18 cm, 10 cm and 12 cm. What is the average length of each piece of string?

Ans: \_\_\_\_\_cm

(Go on to the next page)

Do not write  
in this space

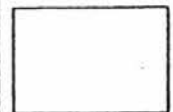

24. The pattern in the box shows part of a tessellation. Extend the tessellation by drawing **two** more unit shapes in the space provided in the box.

Do not write  
in this  
space

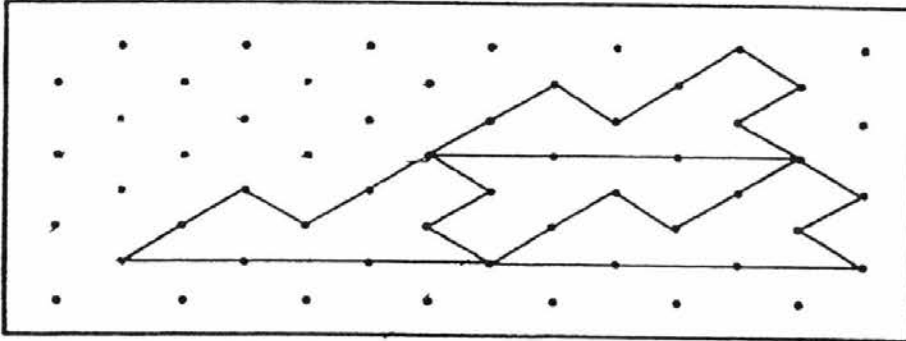

25. The ratio of the mass of Box A to the mass of Box B is 1 : 3. The ratio of the mass of Box B to the mass of Box C is 9 : 5. Express the ratio of the mass of Box A to the mass of Box B to the mass of Box C.

Ans: \_\_\_\_\_

(Go on to the next page)

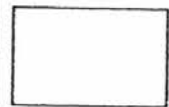

Questions 26 to 30 carry 2 marks each. Show your working clearly in the space provided for each question and write your answers in the spaces provided. For questions which require units, give your answers in the units stated.

(10 marks)

26. PS and PQ form two sides of a trapezium PQRS.  $\angle PQR = 90^\circ$ .

- Complete the drawing of trapezium PQRS.
- Measure and write down the size of  $\angle SPQ$ .

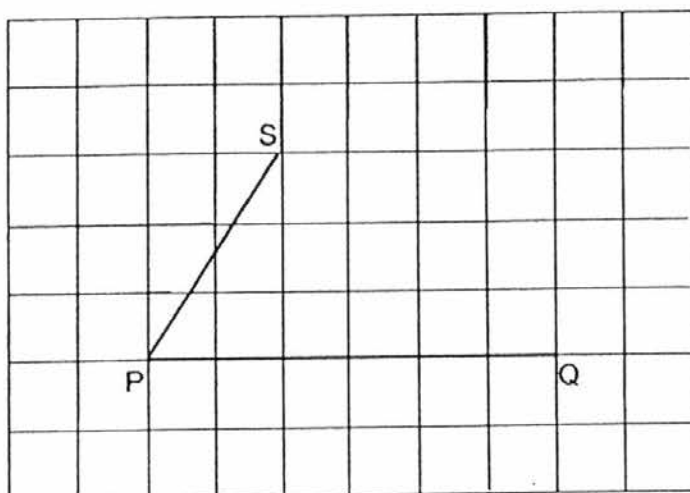

$\angle SPQ = \underline{\hspace{2cm}}^\circ$

27. May and Sue spent a total of \$345. Sue and Ted spent a total of \$505. Ted spent thrice as much as May. How much money did May spend?

Ans: \$                     

(Go on to the next page)

Do not write  
in this  
space

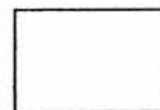

28. 40% of the pupils in the hall are girls. There are 1047 boys. How many pupils are there altogether?

Do not write  
in this  
space

Ans: \_\_\_\_\_

29. Bryan had  $\frac{4}{7}$  as much money as Candy at first. When Candy gave \$45 to Bryan, they had the same amount of money. How much money did Bryan have at first?

Ans: \$ \_\_\_\_\_

30. Charmaine mixed 0.55 l of sugar syrup with 1.85 l of water. The mixture is then poured into bottles of 700 ml each. How much mixture is left over? Express your answer in millilitres.

Ans: \_\_\_\_\_ ml

End of Paper

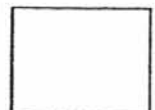



HENRY PARK PRIMARY SCHOOL  
2016 SEMESTRAL EXAMINATION 2  
MATHEMATICS  
PRIMARY 5

PAPER 2

Name: \_\_\_\_\_ (    )

Class: Primary 5 \_\_\_\_\_

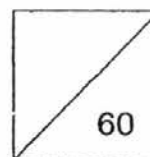

Time for Paper 2: 1 h 40 min

Do not turn over this page until you are told to do so.

Follow all instructions carefully.

Answer all questions.

Show your working clearly as marks are awarded for correct working.

Write your answers in this booklet.

You are allowed to use a calculator.

Questions 1 to 5 carry 2 marks each. Show your working clearly in the space provided for each question and write your answers in the space provided. For questions which require units, give your answers in the units stated.

(10 marks)

1. The figure below is made up of cubes of sides 1 cm. How many **more** 1-cm cubes are needed to form a large cube of side 4 cm?

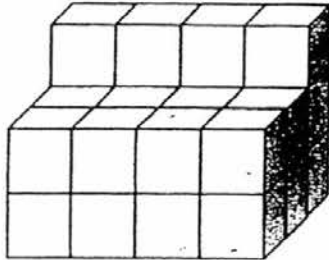

Ans: \_\_\_\_\_

2. Mary bought 3 packets of walnuts at \$1.85 per packet and a packet of berries at \$3.65. She gave the cashier a \$50 note. How much change should she receive?

Ans: \$ \_\_\_\_\_

3. In the figure below, find  $\angle y$ .

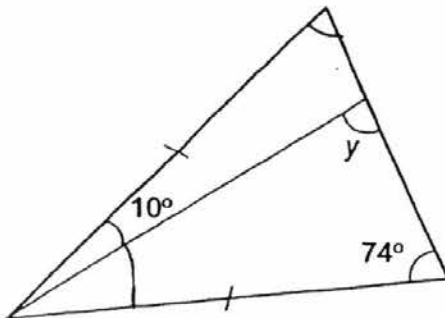

Ans: \_\_\_\_\_ °

(Go on to the next page)

Do not write  
in this space

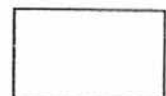

4. Mrs Tee paid a total of \$216 for 3 identical belts and 3 identical dresses. Each dress cost 8 times as much as a belt. Find the difference in price between a dress and a belt.

Ans: \$ \_\_\_\_\_

5. Last year, 81 pupils participated in a Science quiz where there were gold, silver or bronze awards to be won.  $\frac{2}{3}$  of the pupils won either a gold or silver award. 12 of them won bronze awards. How many pupils **did not** win any of the awards?

Ans: \_\_\_\_\_

(Go on to the next page)

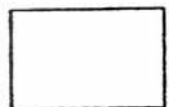



For questions 6 to 18, show your working clearly in the space provided for each question and write your answers in the spaces provided. The number of marks available is shown in brackets [ ] at the end of each question or part-question.

(50 marks)

6.



**TRICK-YOUR-EYES MUSEUM**

Tickets are priced at:  
\$25 each (adult)  
~~\$20~~ \$20 each (child) ~~\$60~~

For every 2 adults and 3 children tickets bought, a \$10 discount will be given.

Do not write  
in this space

Ms Wong and 3 parent volunteers took a class of 30 children to the Trick-Your-Eyes Museum. What was the minimum cost of all the tickets to be bought?

Ans: \_\_\_\_\_ [4]

(Go on to the next page)



7. Charlotte poured 5 cups of water into an empty rectangular tank as shown below. The volume of water in each cup was  $25 \text{ cm}^3$ . How much more water was needed to fill the tank to the brim? Do not write in this space

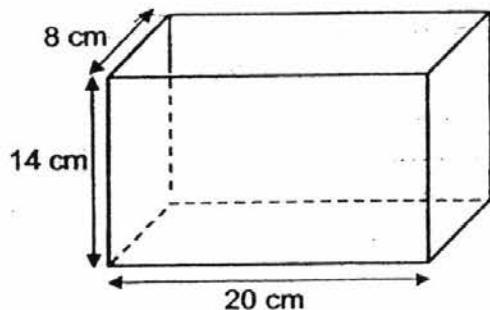

Ans: \_\_\_\_\_ [3]

8. There were 120 apples and 120 oranges in a basket at first.

$\frac{3}{5}$  of the apples and  $\frac{2}{3}$  of the oranges were used in a party.

- (a) How many apples were used in the party?  
(b) How many more oranges than apples were used in the party?

Ans: (a) \_\_\_\_\_ [2]

(b) \_\_\_\_\_ [2]

(Go on to the next page)



9. Sally bought some sweets and chocolates. Each sweet cost \$0.20 and each chocolate cost \$0.50. She bought a total of 22 sweets and chocolates for \$5.60. How many sweets did she buy?

Do not write  
in this space

Ans: \_\_\_\_\_ [3]

10. In the figure below, ABCD is a parallelogram. Find  $\angle z$ .

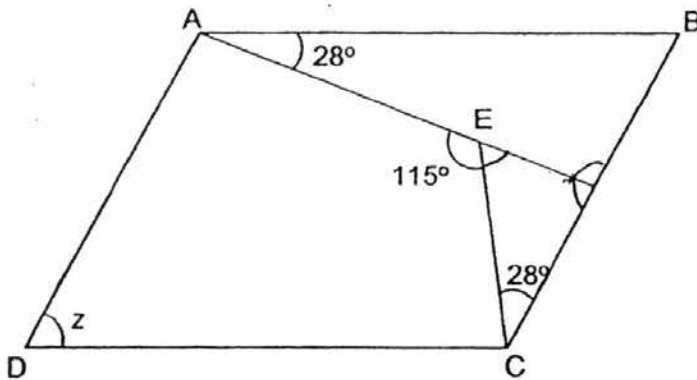

Ans: \_\_\_\_\_ [4]

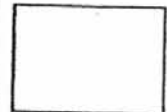

11. Mr Ho gave a sum of money to his son and 5 daughters in the ratio 4 : 11. His son received \$1800. Each of his daughters received an equal amount of money.  
Find the difference between the sum of money received by his son and each of his daughters.

Do not write  
in this space

Ans: \_\_\_\_\_ [3]

(Go on to the next page)



12. Richard and Sean had 60 sweets each. Richard gave 20% of his sweets to Sean. After receiving the sweets from Richard, Sean gave 50% of his total sweets to Tim. How many sweets had Sean left?

Do not write  
in this space

Ans: \_\_\_\_\_ [3]

(Go on to the next page)

13. Mr Tan wanted to place pots of flowers at equal distance apart from each other along the perimeter of his square garden.  
He placed a flower pot at each corner and an equal number of flower pots along each side of the square garden. He had 79 pots of flowers to use.
- a) What was the maximum number of flower pots Mr Tan could use to place along the perimeter of the square garden?
- b) How many flower pots would there be along each side of the square garden including the flower pots at the 2 corners?

Do not write  
in this space

Ans: a) \_\_\_\_\_ [2]

b) \_\_\_\_\_ [3]

(Go on to the next page)

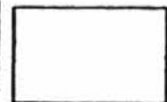

14. The area of rectangle  $AXYD$  is  $\frac{1}{5}$  of the area of the rectangle  $ABCD$ .  
Find the area of the shaded parts.

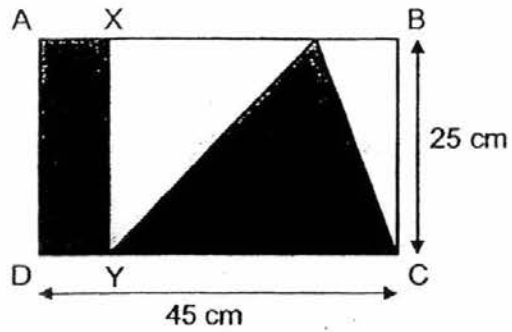

Do not write  
in this space

Ans: \_\_\_\_\_ [3]

(Go on to the next page)

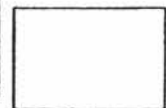

15. In a theatre,  $\frac{4}{9}$  of the audience were adults.  $\frac{1}{4}$  of the adults were women.

There were 160 fewer men than children in the theatre.

a) What fraction of the audience were men?

Give your answer in its simplest form.

b) What was the total number of women and children in the theatre?

Do not write  
in this space

Ans: a) \_\_\_\_\_ [2]

b) \_\_\_\_\_ [3]

(Go on to the next page)

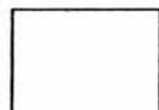



16. Chadrick was training for a swimming competition.

On Day 1 of his training, he swam 600 m.

On Day 2, he swam 0.1 km more than Day 1.

For each subsequent training session, he swam a distance of 0.1 km more than the previous training session.

a) On Day 5 of his training session, how far did he swim?

Give your answer in metres.

b) On which day did he swim a distance of 3 km?

Do not write  
in this space

Ans: (a) \_\_\_\_\_ [2]

(b) Day \_\_\_\_\_ [3]

(Go on to the next page)

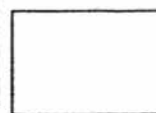

17. The graph below shows the number of books borrowed by visitors at a Community Library on a Sunday.

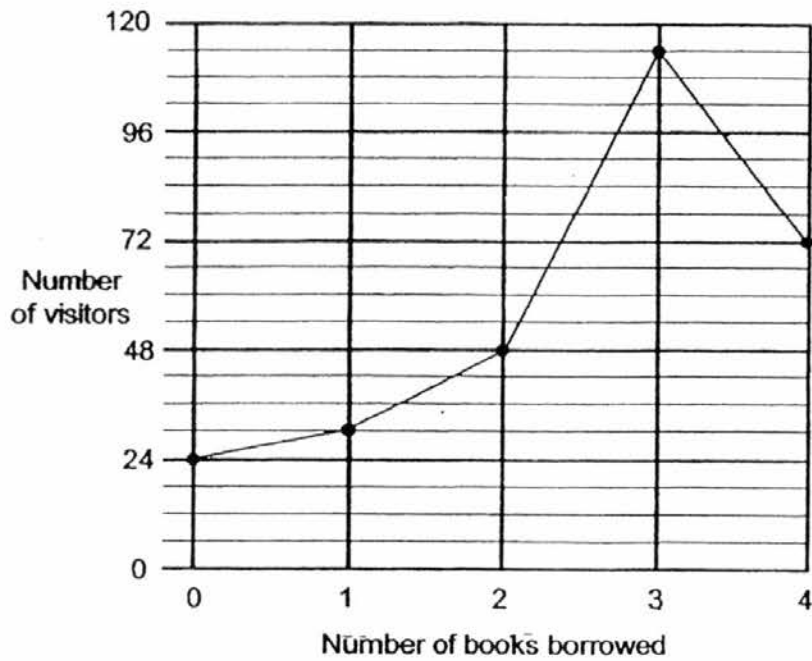

- a) How many visitors visited the Community Library that Sunday?  
b) What was the average number of books borrowed by each visitor that Sunday? Give your answer to the nearest whole number.

Ans: a) \_\_\_\_\_ [1]

b) \_\_\_\_\_ [3]

(Go on to the next page)

Do not write  
in this space

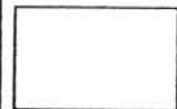

18. Mr Soh paid a total of \$4500 for a cabinet and a refrigerator after a discount of 40%. The ratio of the original price of the cabinet to the original price of the refrigerator was 1 : 2.  
Find the original price of the refrigerator before the discount.

Do not write  
in this space

Ans: \_\_\_\_\_ [4]

-END OF PAPER-

Setters: Mrs Josephine Lai, Ms Yew Hew Mei, Ms Grace Chan, Mr Yip Yew Fei



YEAR : 2016  
 LEVEL : PRIMARY 5  
 SCHOOL : HENRY PARK PRIMARY  
 SUBJECT : MATHEMATICS  
 TERM : SA2

Paper 1

Q1	3	Q4	2	Q7	2	Q10	3	Q13	2
Q2	4	Q5	1	Q8	2	Q11	1	Q14	2
Q3	1	Q6	3	Q9	2	Q12	2	Q15	3

Q16 702

Q17 BC

Q18 11.02 m

Q19 1211.1

Q20 151.67

Q21  $116^\circ - 38^\circ \Rightarrow \underline{78^\circ}$

Q22  $180 \div 3 = 60$   
 $60 + 34 = 94$   
 $94 + 60 = 154$   
 $180 - 154 \Rightarrow \underline{26^\circ}$

Q23  $20 + 18 + 10 + 12 = 60$   
 $60 \div 4 \Rightarrow \underline{15 \text{ cm}}$

Q24

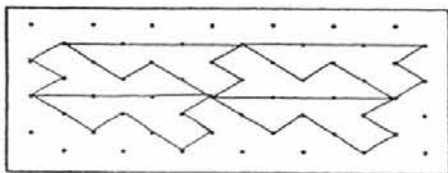

Q25 3 : 9 : 5

Q26a

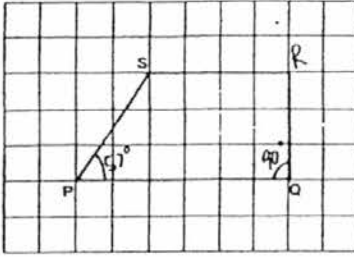

Q26b  $\angle SPQ = 57^\circ$

Q27  $505 - 345 \rightarrow 160$   
 $160 + 2 \Rightarrow \underline{\$80}$

Q28  $60\% \rightarrow 1047$   
 $1\% \rightarrow 1047 \div 60 = 17.45$   
 $100\% \rightarrow 17.45 \times 100 \Rightarrow \underline{1745 \text{ pupils}}$

Q29  $45 \div 3 \rightarrow 15$   
 $15 \times 8 \Rightarrow \underline{\$120}$

Q30  $0.55 + 1.85 \rightarrow 2.40$   
 $2400 \div 700 = 3R30 \Rightarrow \underline{300 \text{ ml}}$

Paper 2

Q1  $4 \times 4 \times 4 \rightarrow 64$   
 $64 - 28 \Rightarrow \underline{36}$

Q2  $1.85 \times 3 \rightarrow 5.55$   
 $50 - 5.55 - 3.65 \Rightarrow \underline{\$40.80}$

Q3  $180^\circ - 10^\circ - 74^\circ \rightarrow 96^\circ$   
 $180^\circ - 96^\circ \Rightarrow \underline{84^\circ}$

Q4  $216 \div 3 = 72$   
 $72 \div 9 = 8$   
 $8 \times 7 \Rightarrow \underline{\$56}$

Q5  $81 \div 3 \rightarrow 27$   
 $27 - 12 \Rightarrow \underline{15 \text{ pupils}}$

- Q6  $30 - 6 = 24$   
 $24 \times 20 = 480$   
 $25 \times 4 = 100$   
 $20 \times 6 = 120$   
 $100 + 120 = 220$   
 $220 - 20 = 200$   
 $200 + 480 \Rightarrow \underline{\$680}$
- Q7  $20 \times 14 \times 8 = 2240$   
 $5 \times 25 = 125$   
 $2240 - 125 \Rightarrow \underline{2115 \text{ cm}^3}$
- Q8a  $120 \div 15 \rightarrow 8$   
 $8 \times 9 \Rightarrow \underline{72 \text{ apples}}$
- Q8b  $8 \times 10 \rightarrow 80$   
 $80 - 72 \Rightarrow \underline{8 \text{ oranges}}$
- Q9  $0.20 \times 22 = 4.4$   
 $5.60 - 4.4 = 1.2$   
 $1.2 \div 0.3 = 4$   
 $22 - 4 \Rightarrow \underline{18 \text{ sweets}}$
- Q10  $180^\circ - 115^\circ = 65^\circ$   
 $180^\circ - 28^\circ - 65^\circ = 87^\circ$   
 $180^\circ - 87^\circ = 93^\circ$   
 $180^\circ - 28^\circ - 93^\circ \Rightarrow \underline{59^\circ}$
- Q11  $1800 \div 4 = 450$   
 $450 \times 11 = 4950$   
 $4950 \div 5 = 990$   
 $1800 - 990 \Rightarrow \underline{\$810}$
- Q12  $12 \div 2 = 6$   
 $60 \div 10 = 6$   
 $6 \times 6 \Rightarrow \underline{36 \text{ sweets}}$
- Q13a  $79 \div 4 \rightarrow 19.75$   
 $19 \times 4 \Rightarrow \underline{76 \text{ flower pots}}$
- Q13b  $76 - 4 = 72$   
 $72 \div 4 = 18$   
 $18 + 2 \Rightarrow \underline{20 \text{ flower pots}}$

Q14  $45 \times 25 = 1125$   
 $1125 + 5 = 225$   
 $225 + 25 = 9$   
 $45 - 9 = 36$   
 $\frac{1}{2} \times 36 \times 25 = 450$   
 $450 + 225 \Rightarrow \underline{675 \text{ cm}^2}$

Q15a  $\frac{3}{9} + 3 \Rightarrow \frac{1}{3}$

Q15b  $5u - 3u = 2u$   
 $2u = 160$   
 $1u = 160 + 2 = 80$   
 $80 \times 5 = 400$   
 $400 + 80 \Rightarrow \underline{480}$

Q16a  $0.1 \text{ km} = 100 \text{ m}$

Day 2  $\rightarrow 600 + 100 = 700$   
Day 3  $\rightarrow 700 + 100 = 800$   
Day 4  $\rightarrow 800 + 100 = 900$   
Day 5  $\rightarrow 900 + 100 \Rightarrow \underline{1000 \text{ m}}$

Q16b  $3 \text{ km} = 3000 \text{ m}$

Day 6  $\rightarrow 1000 + 100 = 1100$   
 $\downarrow \downarrow \downarrow$   
Day 25  $\rightarrow 2900 + 100 = 3000 \text{ m}$

Q17a  $114 + 72 + 48 + 30 + 24 \Rightarrow \underline{288 \text{ visitors}}$

Q17b  $(30 \times 1) + (48 \times 2) + (114 \times 3) + (72 \times 4) = 756$   
 $756 + 288 = 2.625 \approx \underline{3 \text{ books}}$

Q18  $4500 + 60 = 75$   
 $75 \times 100 = 7500$   
 $7500 + 3 = 2500$   
 $2500 \times 2 \Rightarrow \underline{\$5000}$

End