



Rosyth School
First Continual Assessment 2015
Primary 5 Mathematics

Name: _____ Register No. _____

Class: Pr 5 - _____

Date: 27th February 2015 Parent's Signature: _____

Total Time for Booklets A and B : 50 minutes

PAPER 1
(Booklet B)

Instructions to Pupils:

1. Do not open this booklet until you are told to do so.
2. Follow all instructions carefully.
3. You are **not** allowed to use a calculator.
4. Answer all questions.

Section	Maximum Mark	Marks Obtained
Paper 1 (Booklet B)	20	

*** This booklet consists of 7 pages (including this cover page)**

Questions 16 to 25 carry 1 mark each. Write your answers in the spaces provided. For questions which require units, give your answers in the units stated.

(10 marks)

16. What is the missing number in the box?

$$2.476 = 2 + 0.4 + \boxed{} + 0.006$$

Ans: _____

17. Express $5\frac{13}{1000}$ as a decimal.

Ans: _____

18. The difference between 4 tenths and 23 thousandths is _____.

Ans: _____

19. In the diagram below, the letters M, A, T and H are drawn on a square grid. List all the letters which have perpendicular lines.

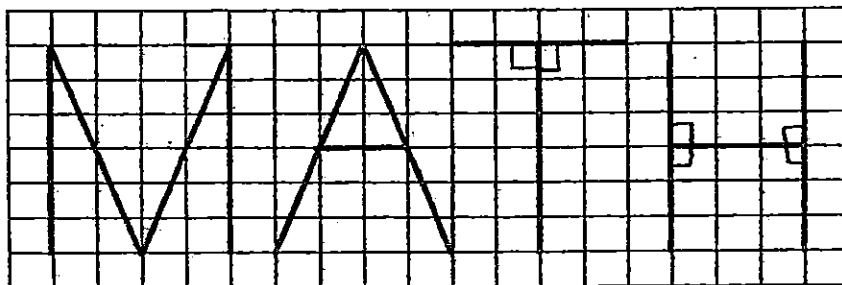

Ans: _____

20. Express $\frac{22}{25}$ as a decimal.

Ans: _____

21. Find the product of 154 and 27.

Ans: _____

22. The table below shows the prices of identical toy cars sold at two stalls.

Stall A	2 for \$3
Stall B	5 for \$6

Which stall offers a lower price for a toy car?

Ans: _____

23. Find the value of $100 + 50 \div 5 \times 6 - 14$.

Ans: _____

24. Arrange the following decimals from the biggest to the smallest.

0.09, 2.015, 2.105, 0.19

Ans: _____, _____, _____, _____

25. How many lines of symmetry are there in this figure?

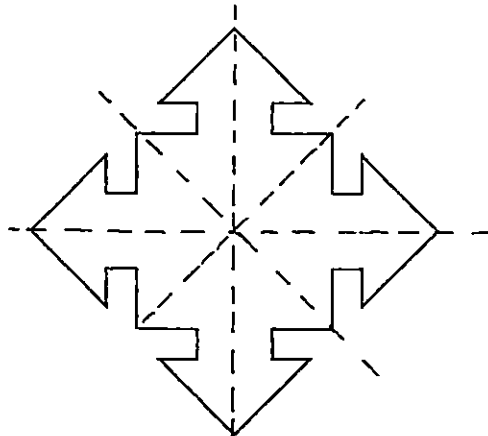

Ans: _____

Questions 26 to 30 carry 2 marks each. Show your workings clearly in the space provided for each question and write your answers in the spaces provided. For questions which require units, give your answers in the units stated.

(10 marks)

26. The figure below shows a rectangular field.

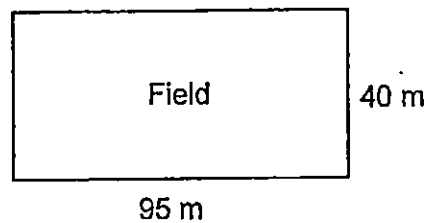

Bala ran 5 times around the field. What was the total distance covered by him?

Ans: _____ m

27. Durian puffs are only sold in boxes of 8. Each box is sold at \$9.50. Alison wants to buy 72 durian puffs. How much does she pay for all the durian puffs?

Ans: \$ _____

28. The figure below is made up of a square and a rectangle. Find the perimeter of the figure below.

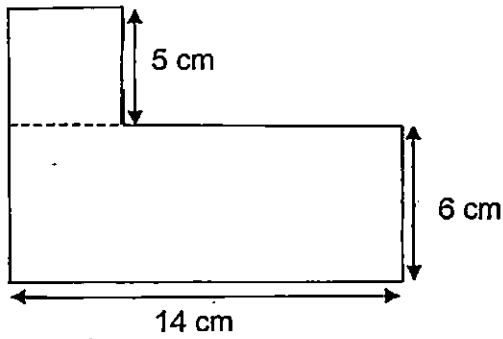

Ans: _____ cm

29. Jane, Henna and Devi had some rubber bracelets. The graph below shows the number of rubber bracelets each girl had.

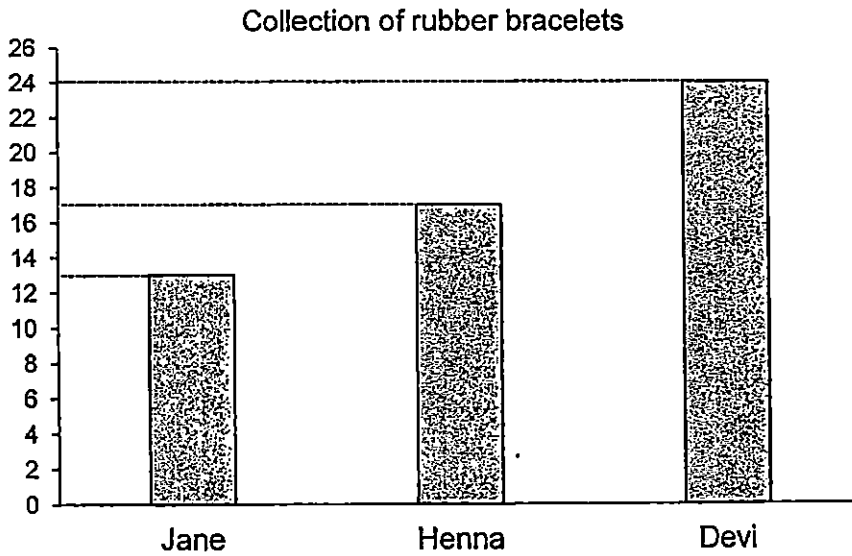

They sold all their rubber bracelets for \$3 each. How much did they receive after selling all their rubber bracelets?

Ans: \$ _____

30. The figure below is made up of a square and a rectangle. Find the shaded area of the figure.

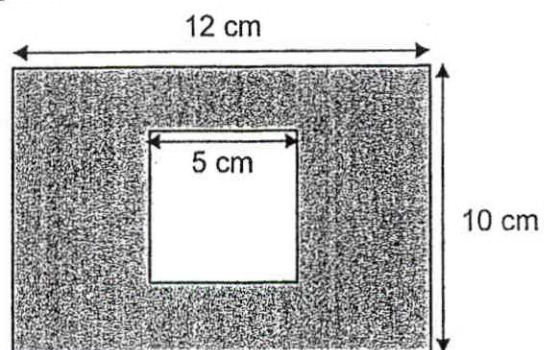

Ans: _____ cm^2

End of Paper 1



**Rosyth School
First Continual Assessment 2015
Primary 5 Mathematics**

Name: _____ Register No. _____

Class: Pr 5 - _____

Date: 27th February 2015 Parent's Signature: _____

Total Time for Booklets A and B : 50 minutes

**PAPER 1
(Booklet A)**

Instructions to Pupils:

1. Do not open this booklet until you are told to do so.
2. Follow all instructions carefully.
3. You are not allowed to use a calculator.
4. Answer all questions.

Section	Maximum Mark	Marks Obtained
Paper 1 (Booklet A)	20	

* This booklet consists of 7 pages (including this cover page)

Questions 1 to 10 carry 1 mark each. Questions 11 to 15 carry 2 marks each. For each question, four options are given. One of them is the correct answer. Make your choice (1, 2, 3 or 4). Shade the oval (1, 2, 3 or 4) on the Optical Answer Sheet.

(20 marks)

1. Which of the following numbers is two million, five hundred and three thousand, one hundred and eight?

- (1) 2 053 108
- (2) 2 503 108
- (3) 2 530 108
- (4) 2 530 580

2. Round off 278 430 to the nearest ten thousands.

- (1) 278 000
- (2) 278 400
- (3) 280 000
- (4) 300 000

3. If the perimeter of a square is 64 m, what is the length of one side of the square?

- (1) 8 m
- (2) 16 m
- (3) 32 m
- (4) 48 m

4. 7 hundreds, 8 tenths and 3 thousandths is _____.

(1) 700.083

(2) 700.380

(3) 700.803

(4) 780.003

5. Which one of the following numbers is the largest?

(1) 8.610

(2) 8.016

(3) 8.606

(4) 8.061

6. $20 \div 1000 =$ _____.

(1) 0.002

(2) 0.020

(3) 5

(4) 50

7. $6.038 \times$ _____ $= 6.038$.

(1) 1

(2) 10

(3) 100

(4) 1 000

8. Which figure below is symmetrical?

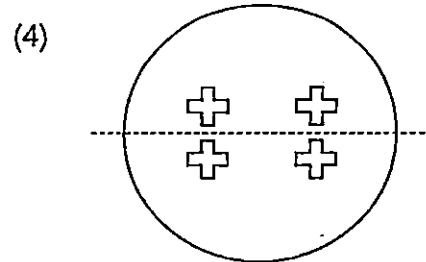
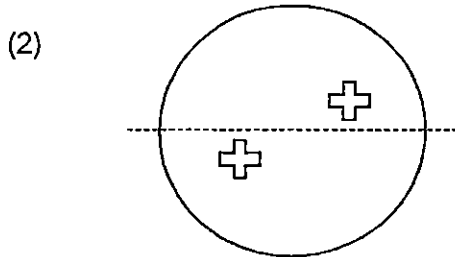
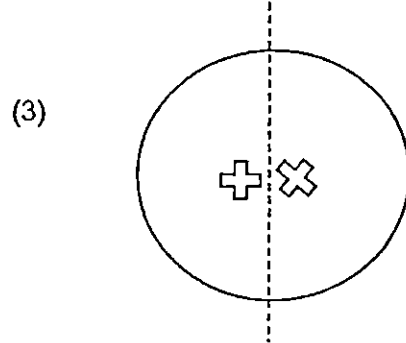
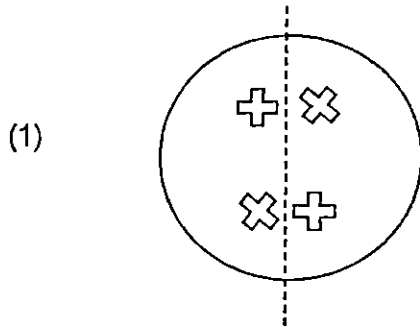

9. Express $1\frac{1}{5}$ as a decimal.

- (1) 1.15
- (2) 1.2
- (3) 1.3
- (4) 1.315



Rosyth School
First Continual Assessment 2015
Primary 5 Mathematics

Name: _____ Register No. _____

Class: Pr 5 - _____

Date: 27th February 2015 Parent's Signature: _____

Time: 1 h 15 min

PAPER 2

Instructions to Pupils:

1. Do not open this booklet until you are told to do so.
2. Follow all instructions carefully.
3. Show your workings clearly as marks are awarded for correct working.
4. Write your answers in this booklet.
5. You are allowed to use a calculator.
6. Answer all questions.

Questions	Maximum Mark	Marks Obtained
Q 1 to 5	10	
Q 6 to 13	30	

Section	Maximum Mark	Marks Obtained
Paper 1	40	
Paper 2	40	
Total	80	

*** This booklet consists of 12 pages (including this cover page)**

Questions 1 to 5 carry 2 marks each. Show your working clearly in the space provided for each question and write your answers in the spaces provided. For questions which require units, give your answers in the units stated.

Do not write in this space.

(10 marks)

1. The pattern in the box shows part of a tessellation. Extend the tessellation by drawing two more unit shapes in the space provided.

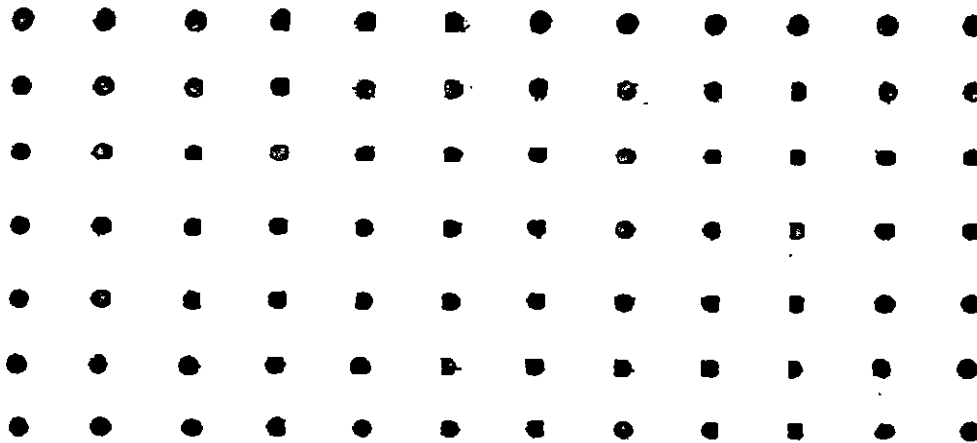

2. Omar had 6250 cm of string. He cut it into 10 equal pieces. What would be the length of each piece of string? (Express your answer in metres)

Ans: _____ m

3. List all the common factors of 30 and 36.

Do not write
in this space

Ans: _____

4. In a hall, there are 45 green and 27 blue chairs arranged in rows. Mr Singh wants to rearrange the chairs such that each row has the same number of chairs and are of the same colour. What is the greatest number of chairs in each row?

Ans: _____

5. The graph below shows the number of boxes of cookies sold by Ali and Ben for the past 6 months. For every sale above 2 000 boxes per month, the salesman would receive \$135 in cash. What is the difference in the amount of cash received by the 2 men in the 6-month period?

Do not write in this space

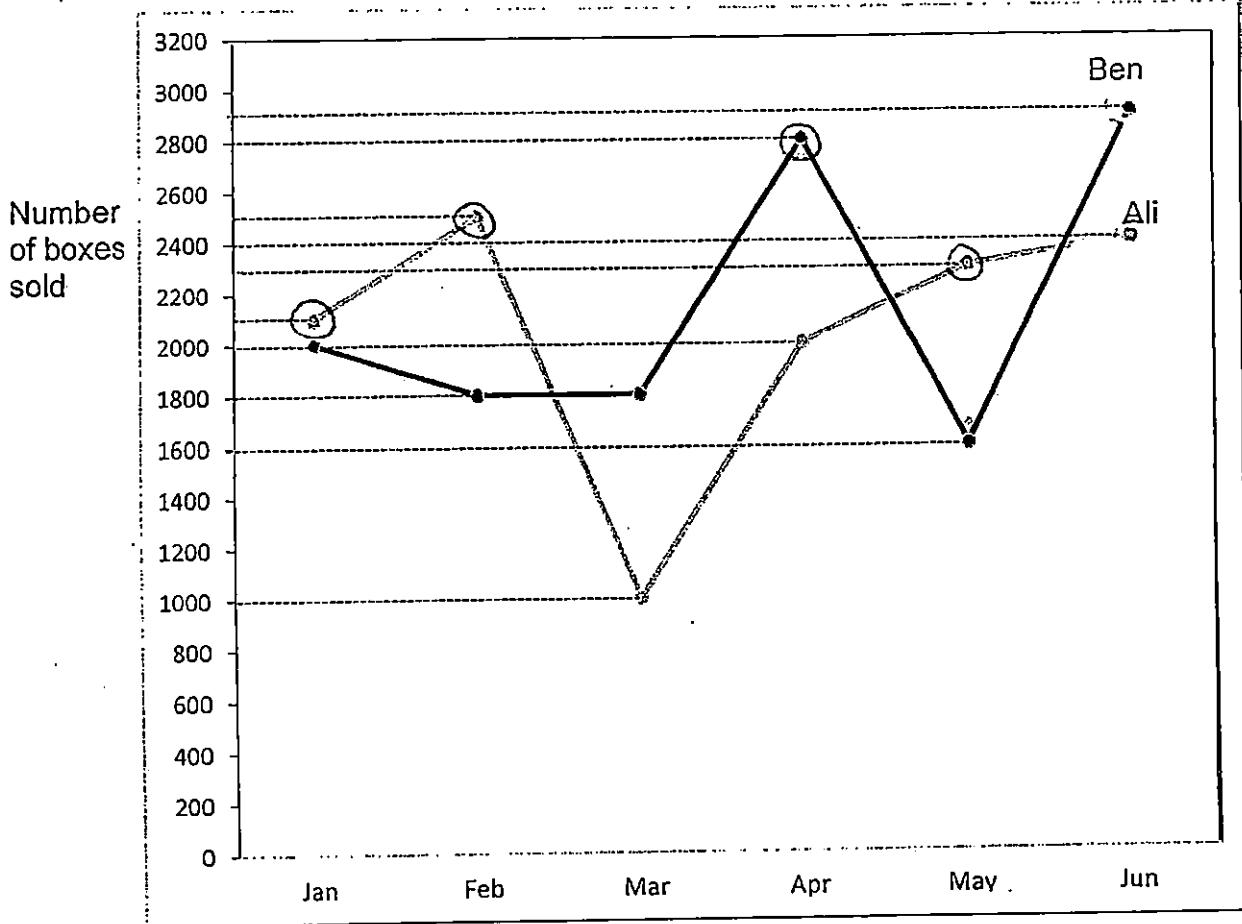

Ans: \$ _____

Questions 6 to 13, show your working clearly in the space provided for each question and write your answers in the spaces provided. The number of marks available is shown in brackets [] at the end of each question or part-question.

(30 marks)

Do not write
in this space

6. Mdm Zuresh is 43 years old. Her son is 7 years old. In how many years' time will Mdm Zuresh be four times as old as her son?

Ans: _____ [3m]

7. Given that Square A and Rectangle B have the same area, find the perimeter of Rectangle B.

Do not write
in this space

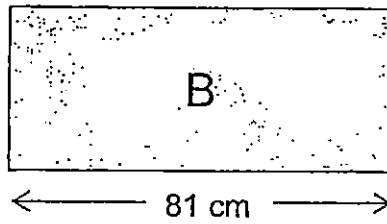
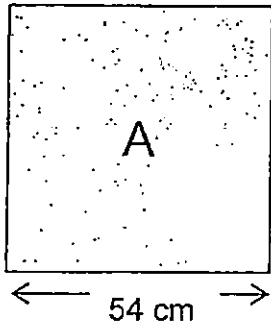

Ans: _____ [3m]

8. Wendy wants to decorate a Christmas tree with coloured bulbs. She wants to use bulbs of 2 different colours. The blue bulbs blink every 6 seconds and red bulbs blink every 8 seconds.

Do not write
in this space

(a) How many times do the red bulbs blink in a minute?

(b) How many times do the blue and red bulbs blink at the same time in a minute?



Ans: (a) _____ (1m)

Ans: (b) _____ (2m)

(Go on to the next page)

9. Rosemary, Pat and Siti have some stickers. Rosemary has four times as many stickers as Pat. The total number of Rosemary's and Pat's stickers is twice that of Siti's. Rosemary has 159 more stickers than Siti. Find the total number of stickers the three girls have.

Do not write
in this space

Ans: _____ (3m)

10. Jack bought a pair of pants that cost \$25 more than a shirt and \$8 less than a bag. He bought 3 pairs of pants, 2 shirts and 2 bags and paid a total of \$379. How much did each pair of pants cost?

Do not write
in this space

Ans: : _____ [4m]

11. 7 files and 4 storybooks cost \$108.
5 files and 3 storybooks cost \$80.
Find the total cost of 1 file and 1 storybook.

Do not write
in this space

Ans: : _____ [5m]

12. During a National Day celebration ceremony, flag poles were placed from one end to the other end of a corridor. The flag poles were placed at an equal distance of 50 cm apart from each other. The corridor was 15m long. The width of the flag poles was insignificant and did not affect the distance covered.

Do not write
in this space

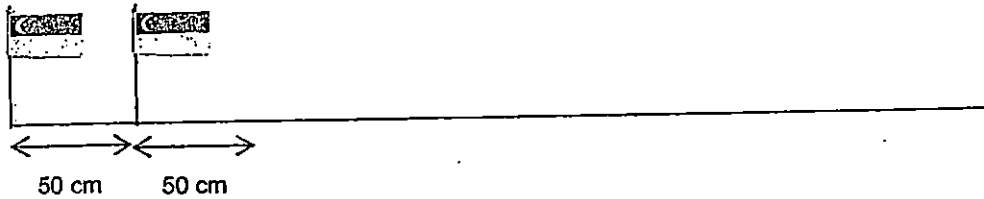

- (a) Find the total number of flag poles required for the event.
- (b) On the day of the celebration, 5 flag poles were removed and placed elsewhere. As a result, the remaining flagpoles were rearranged from one end to the other end of the corridor at a new equal spacing. What was the new spacing between 2 flag poles?

Ans: (a) _____ [2m]

(b) _____ [3m]

13. A piece of ribbon and a stick were of equal length. After Jeffrey cut 4.2 cm from the ribbon and 35.2 cm from the stick, the length of the remaining ribbon was 5 times as long as the remaining stick. What was the total length of the ribbon and stick at first?

Do not write
in this space

Ans: _____ [4m]

End of Paper

Have you checked your work thoroughly?



EXAM PAPER 2015

LEVEL : PRIMARY 5
SCHOOL : ROSYTH SCHOOL
SUBJECT : MATHS
TERM : CA1

Q1	Q2	Q3	Q4	Q5	Q6	Q7	Q8	Q9	Q10
2	3	2	3	1	2	4	4	2	1
Q11	Q12	Q13	Q14	Q15					
2	1	3	3	3					

- Q16. 0.07
 Q17. 5.013
 Q18. 0.377
 Q19. T and H
 Q20. 0.88
 Q21. 4158
 Q22. Stall B
 Q23. 146
 Q24. 2.105, 2.015, 0.190, 0.90
 Q25. 4
 Q26. 1350m
 $95m + 95m = 190m$, $40m + 40m = 80m$, $190m + 80m = 270m$ (1 round),
 $270m \times 5 = 1350m$
 Q27. $\$85.50 \rightarrow 72 \div 8 = 9$ (boxes), $9 \times \$9.50 = \85.50
 Q28. $50cm \rightarrow 15cm + 9cm + 12cm + 14cm = 50$
 Q29. $\$162 \rightarrow 13 + 17 = 30$, $30 + 24 = 54$, $54 \times \$3 = \162
 Q30. $95cm^2$
 $12cm \times 10cm = 120cm^2$ (total area)
 $5cm \times 5cm = 25cm^2$ (area of square)
 $120cm^2 - 25cm^2 = 95cm^2$ (shaded area)

Q1. SEE PICTURE

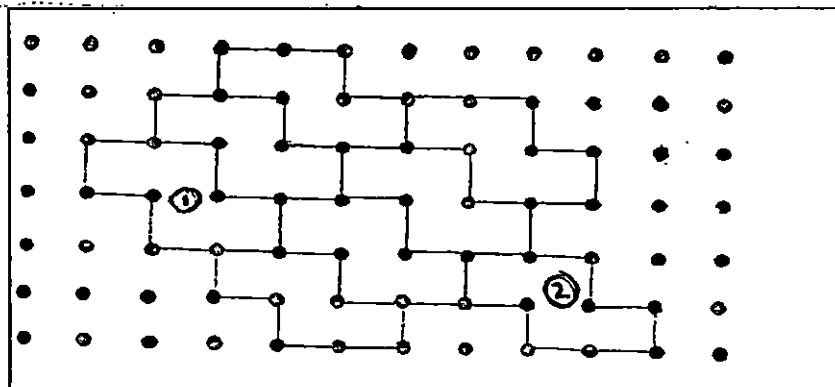

- Q2. $6.25m \rightarrow 6250cm = 62.50m$, $62.50m \div 10 = 6.25m$
 Q3. 1,2,3, and 6 $\rightarrow 30 \rightarrow 1,2,3,5,6,10,15,30$ $36 \rightarrow 1,2,3,4,6,9,12,18,36$
 Q4. $9 \rightarrow 45 \rightarrow 1,3,5,9,15,45$ $27 \rightarrow 1,3,9,27$
 Q5. $\$270$

	J	F	M	A	M	J
A \rightarrow	135	135	0	0	135	135
B \rightarrow	0	0	0	135	0	135

$\$135 \times 4 = \540
 $2 \times \$135 = \270
 $\$540 - \$270 = \$270$

Q6. In 5 years

Years	Now	1	2	3	4	5
2	43	44	45	46	47	48
5	7	8	9	10	11	12

↓
5 times older

↓
4 times older

Q7. 234cm

$$54\text{cm} \times 54\text{cm} = 2916\text{cm}^2 \text{ (Area of A)}$$

$$2916\text{cm}^2 \text{ (Area of B)}$$

$$2916\text{cm}^2 \div 81\text{cm} = 36\text{cm} \text{ (Breadth of B)}$$

$$81\text{cm} \times 2 = 162\text{cm}$$

$$36\text{cm} \times 2 = 72\text{cm}$$

$$162\text{cm} + 72\text{cm} = 234\text{cm}$$

Q8a. 7

Q8b. 2

a) The red bulb blinks 7 times in a minute

b) They both blink 2 times at the same time in a minute.

$$1 \text{ minute} = 60 \text{ seconds}$$

$$60 \div 8 = 7 \text{ R}4$$

Multiples of 8 → 8,16,24,32,40,48,56

Multiples of 6 → 6,12,18,24,30,36,42,48,54,60

Q9 795

$$3u = 159, U = 159 \div 3 = 53$$

$$15u = 53 \times 15 = 795$$

Q10. \$59

$$5 \times 25 = 125, 2 \times 8 = 16, 125 + 16 = 141, 379 - 141 = 238$$

$$7U = 238, U = 238 \div 7 = 34, 34 + 25 = 59$$

Q11. \$24

$$7F + 4S = \$108 \text{ ----- (1)}$$

$$5F + 3S = \$80 \text{ ----- (2)}$$

$$21F + 12S = \$324 \text{ ----- (3)}$$

$$20F + 12S = \$320 \text{ ----- (4)}$$

$$1F = \$324 - \$320 = \$4$$

$$5F = \$4 \times 5 = \$20$$

$$\$80 - \$20 = \$60$$

$$3S = \$60, S = \$60 \div 3 = \$20, \$4 + \$20 = \$24$$

Q12a. 31 → 15M = 1500CM, 1500CM ÷ 50CM = 30, 30 + 1 = 31

Q12b. 60cm → 31 - 5 = 26, 26 - 1 = 25, 25 gaps = 1500cm, 1 gap = 1500cm ÷ 25 = 60cm

Q13. 85.9cm

$$35.2\text{cm} - 4.2\text{cm} = 31\text{cm}, 4U = 31\text{cm}, U = 31\text{cm} \div 4 = 7.75\text{cm}, 5U = 7.75\text{cm} \times 5 = 38.75\text{cm}$$

$$38.75\text{cm} + 4.2\text{cm} = 42.95\text{cm}, 42.95\text{cm} \times 2 = 85.9\text{cm}$$