

Name: \_\_\_\_\_ ( )

Parent's Signature: \_\_\_\_\_

Class: Pr. 4 \_\_\_\_\_

Date: \_\_\_\_\_

Total time for Section A and B: 50 minutes

**Section A: Multiple-Choice Questions (14 x 2 = 28 marks)**

For Questions 1 to 14, choose the most suitable answer and shade its number in the OAS provided

1. Study the classification chart below.

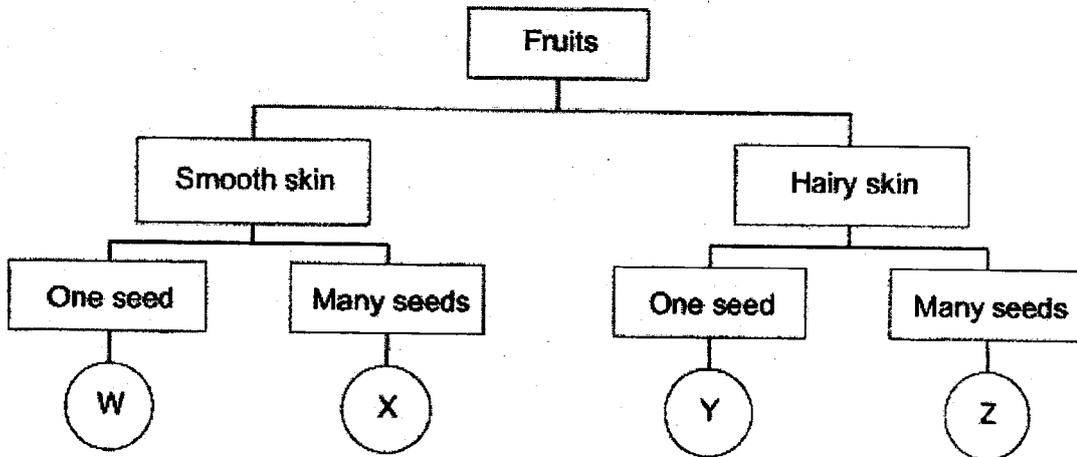

Which of the following best represents the fruit shown below?

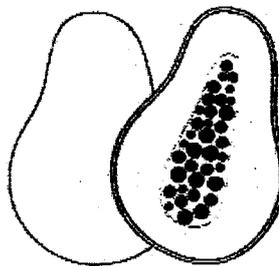

- (1) W
- (2) X
- (3) Y
- (4) Z

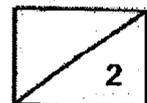

2. Which of the following about living things is not true?

- (1) Living things grow.
- (2) Living things reproduce.
- (3) Living things need only air and water to survive.
- (4) Living things respond to changes in the environment.

3. Johari observed two animals, S and T. He recorded his observations in the table below.

Observation	Animal S	Animal T
Eggs are laid in water	Yes	Yes
Life cycle has a pupa stage	No	Yes

Based on the table above, what could Animal S and Animal T be?

	Animal S	Animal T
(1)	Cockroach	Frog
(2)	Frog	Mosquito
(3)	Mosquito	Butterfly
(4)	Cockroach	Mosquito

4. David found an insect in the garden. A, B, C and D are the various stages in the life cycle of this insect.

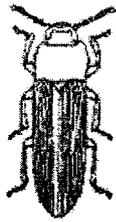

A



B



C



D

Which of the following represents the life cycle of this insect?

(1)

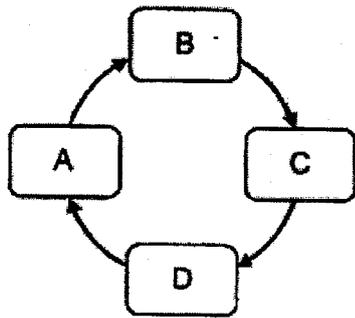

(2)

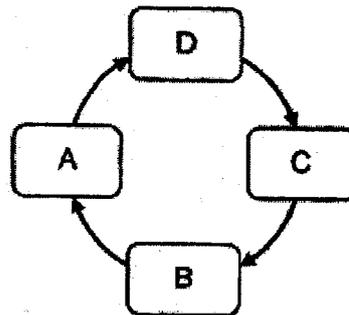

(3)

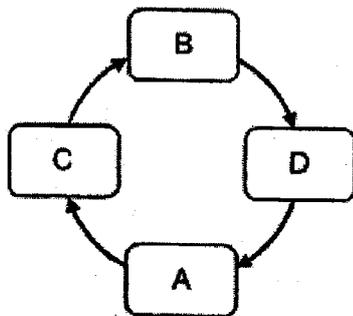

(4)

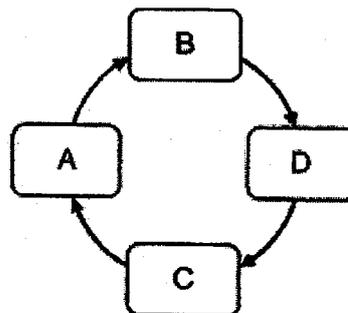

5. Study the diagram below. A, B, C and D are parts of the digestive system. Which parts of the system produce digestive juices?

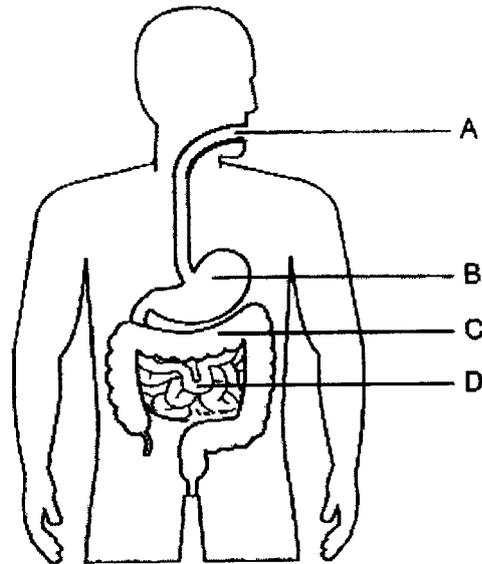

- (1) A, B and C only
- (2) A, B and D only
- (3) B, C and D only
- (4) A, B, C and D

6. Jasmine is playing badminton with her friend.

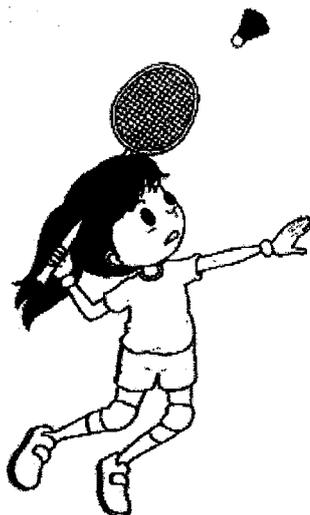

Which of the following systems work together to help her play badminton?

- A Skeletal system
- B Muscular system
- C Circulatory system
- D Respiratory system

- (1) A and B only
- (2) A and C only
- (3) B, C and D only
- (4) A, B, C and D

7. Study the picture of the plant below.

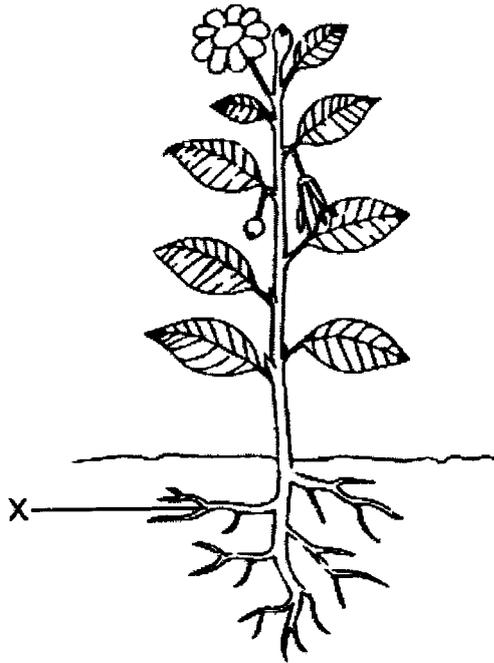

What is/are the function(s) of the part X?

- A Holds the plant upright
- B Absorbs water for the plant
- C Holds the plant firmly to the ground

- (1) A only
- (2) B only
- (3) B and C only
- (4) A, B and C

8. An experiment was conducted to measure the amount of red-coloured water absorbed by four different materials, A, B, C and D. The materials were cut into strips of equal length, size and thickness. They were dipped into the water as shown in the diagram below.

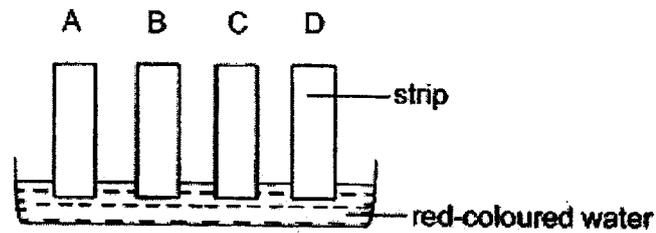

After 10 minutes, the amount of red-coloured water absorbed by the four rectangular strips are shown in the diagram below.

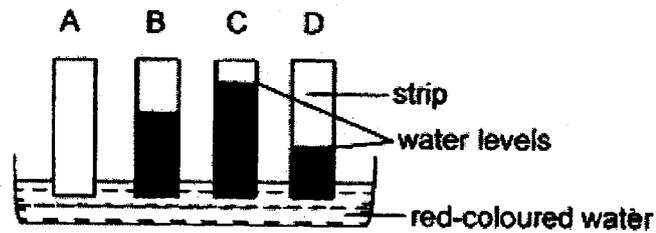

Based on the results above, which material, A, B, C or D, is most suitable for making Part Y of the raincoat as shown below?



- (1) A
- (2) B
- (3) C
- (4) D

9. Dayna took some ice cubes from the freezer and put them into a jug as shown below.

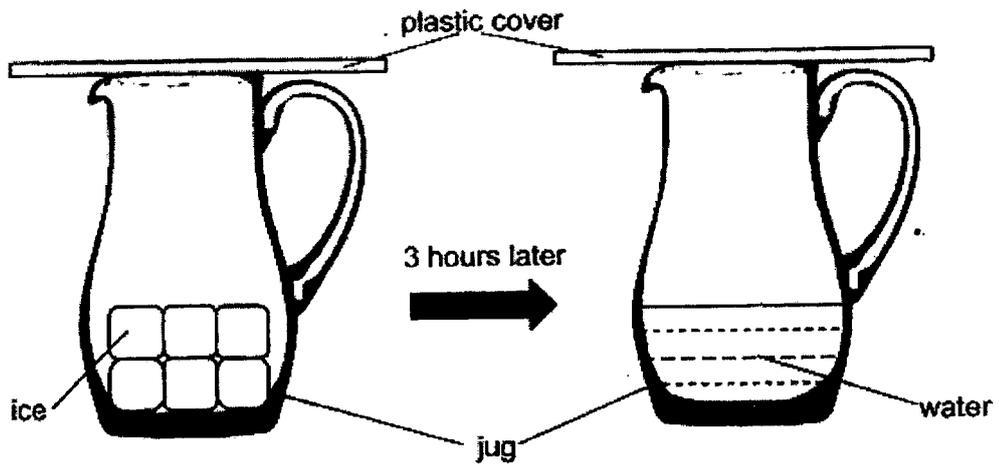

Which property/properties of the ice changed after 3 hours?

- A mass
  - B state
  - C colour
  - D shape
- (1) B only  
(2) C only  
(3) A and D only  
(4) B and D only



10. Keith has a block of plasticine, which has a mass of 500 g and a volume of 100 cm<sup>3</sup>. He pressed the block of plasticine and observed that its shape has changed.

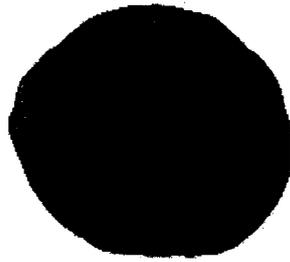

before Keith pressed it



after Keith pressed it

Which of the following correctly represents the mass and volume of the block of plasticine after it was pressed?

	Mass (g)	Volume (cm <sup>3</sup> )
(1)	500	90
(2)	400	90
(3)	500	100
(4)	400	100

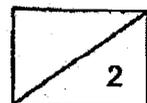

11. Jacob arranged some magnets as shown below.

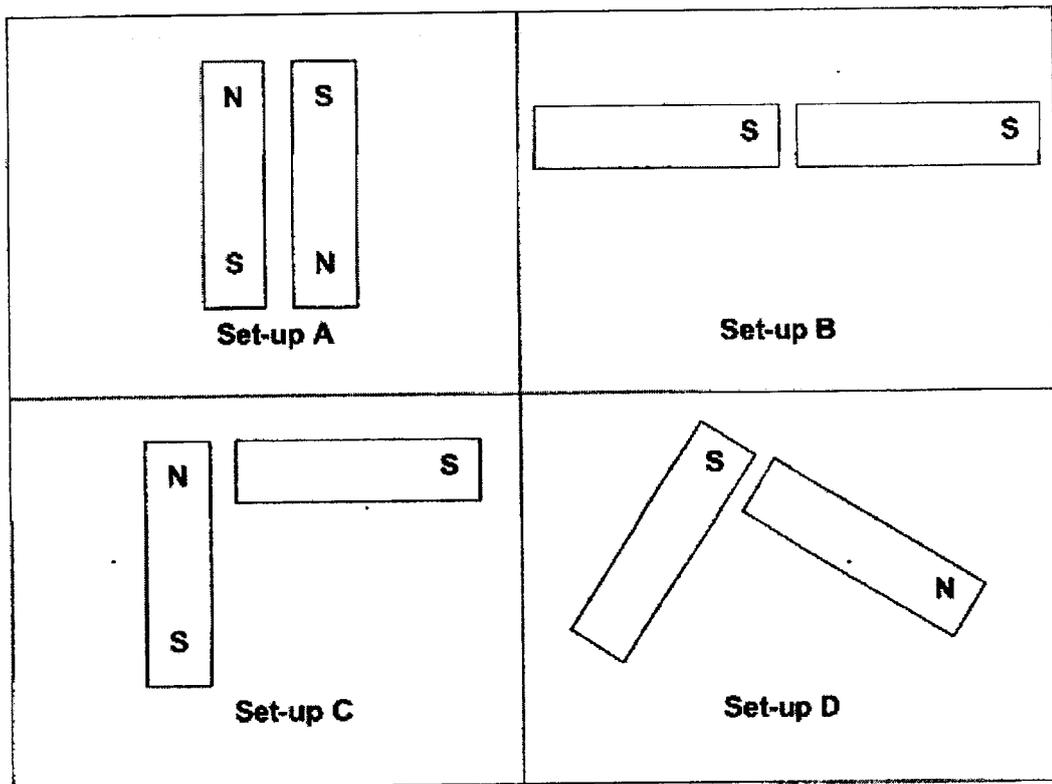

In which pair of set-ups would the two magnets repel each other?

- (1) A and B
- (2) A and C
- (3) B and D
- (4) C and D

12. Jane suspended three identical magnets from a fixed rod using identical springs. She then placed objects X, Y and Z, below the magnets as shown in the diagram below.

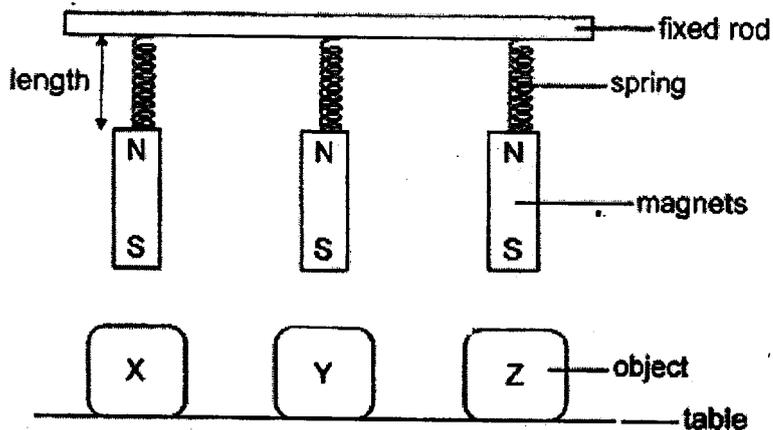

She recorded the lengths of the spring in the table below.

Object	Length of spring (cm)	
	Before object was placed	After object was placed
X	3	6
Y	3	1
Z	3	3

Based only on the information given above, which of the following statements is true?

- (1) Object X repels the magnet.
- (2) Object Y attracts the magnet.
- (3) Object Y is made of a non-magnetic material.
- (4) Object Z is made of a non-magnetic material.

13. Clara poured some cold milk into a flask and placed it in a basin of hot water as shown in the diagram below. She left the set-up below in a room at 30°C for an hour.

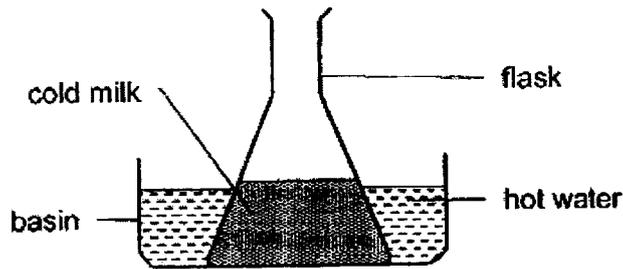

Which one of the following graphs represents the changes in the temperatures of the cold milk and hot water over an hour?

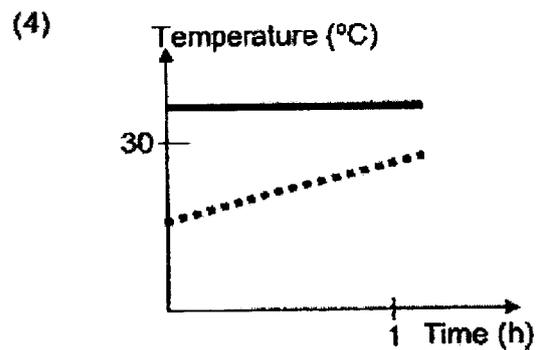
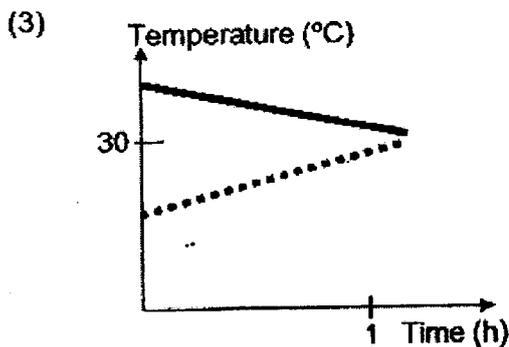
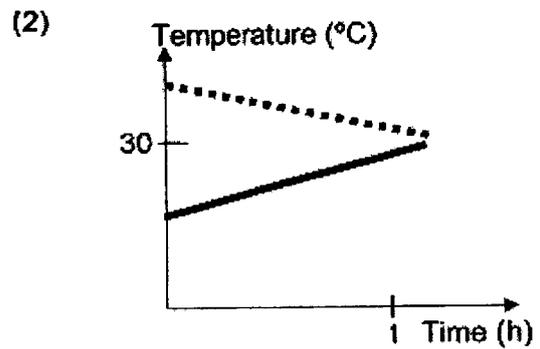
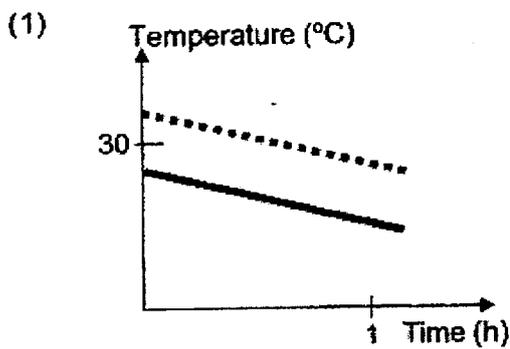
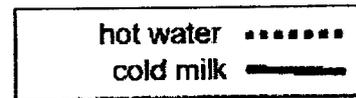

14. Some ice cubes were dropped into a glass of hot coffee.

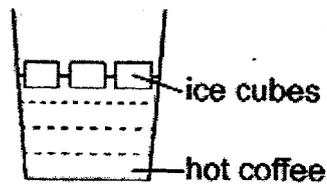

Which of the following changes will most likely take place?

- A The ice cubes will gain heat.
  - B The hot coffee will lose heat.
  - C The temperature of the coffee will remain the same.
- (1) A only  
(2) B only  
(3) A and B only  
(4) B and C only

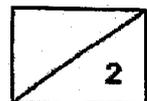

**Section B: Open-ended Questions (3 x 4 = 12 marks)**

15. (a) The diagram below shows the life cycles of insects, M and N.

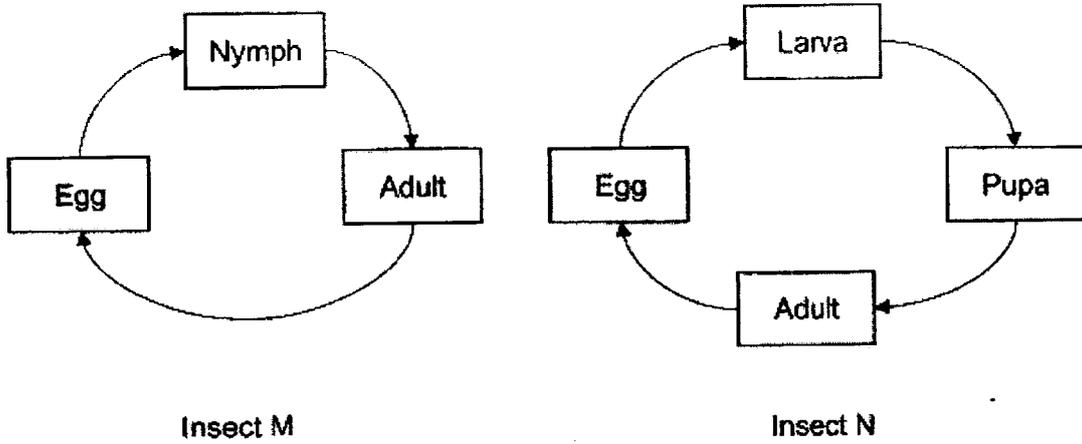

- (i) Based on the diagrams above, state one difference between the two life cycles. Do not compare shape and size. (1m)

---

---

- (ii) Give one example of insect M. (1m)

---

(b) Study the pictures of the different stages of a plant.

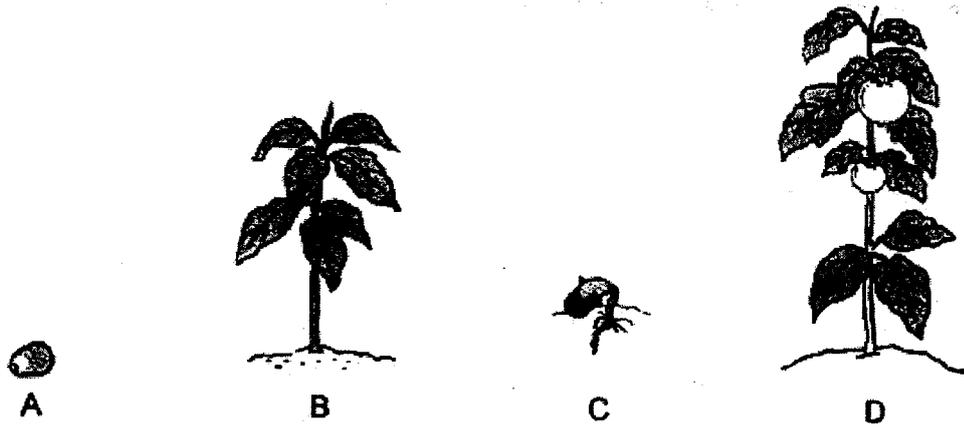

(i) Arrange the stages in the correct order. (1m)

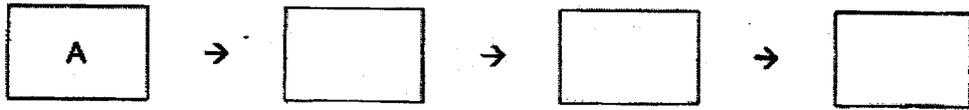

(ii) At which stage(s) can the Plant Q make its own food? Why? (1m)

---

---

16. (a) Use the flow chart to classify the following objects.  
Write the objects in the spaces below. (2m)

water	shadow	air	rock
-------	--------	-----	------

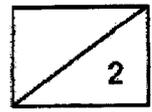
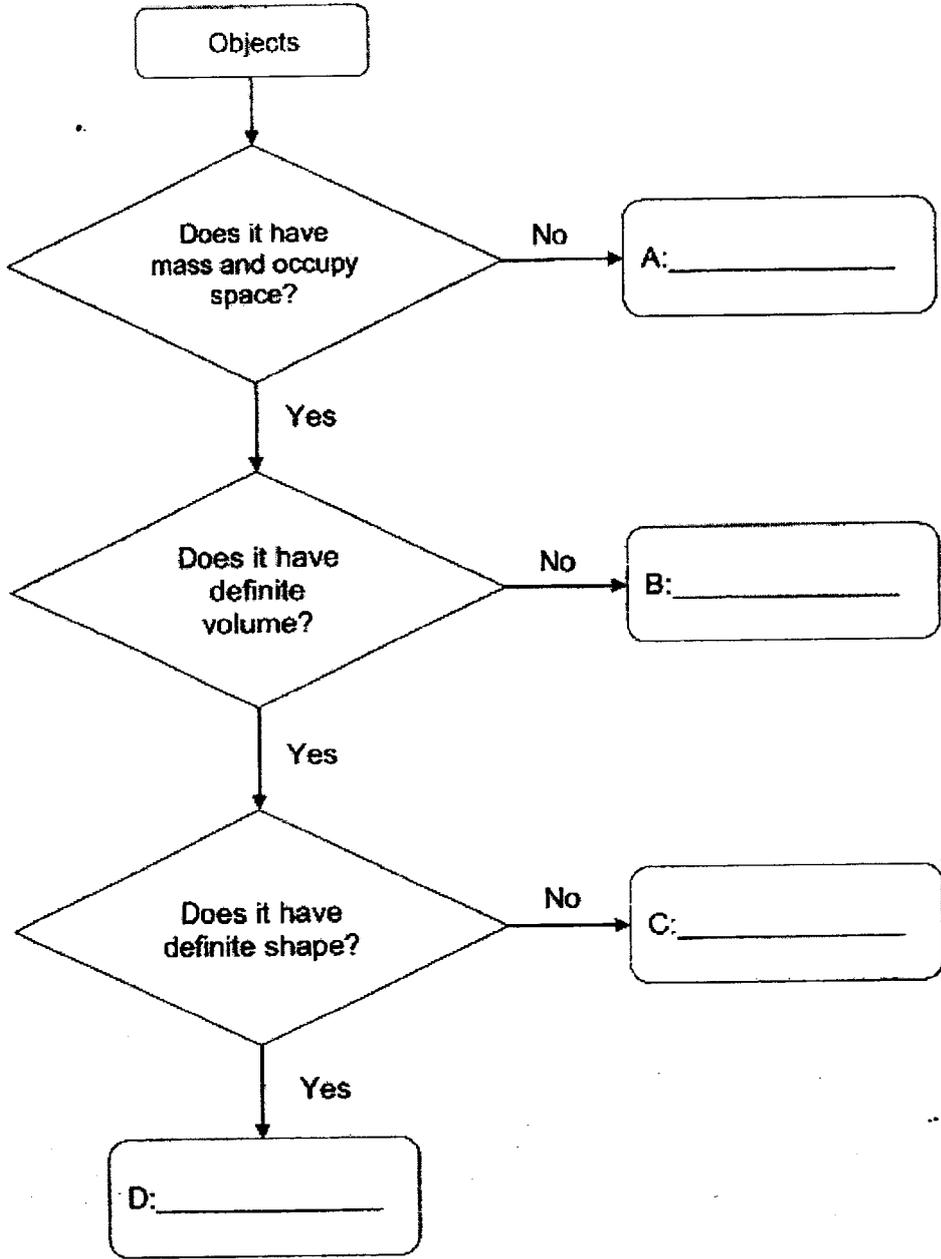



- (b) Adriel completely filled two identical syringes, one with air and the other with water, as shown in the diagram below. He noted that the initial readings on both syringes were at 10 cm.

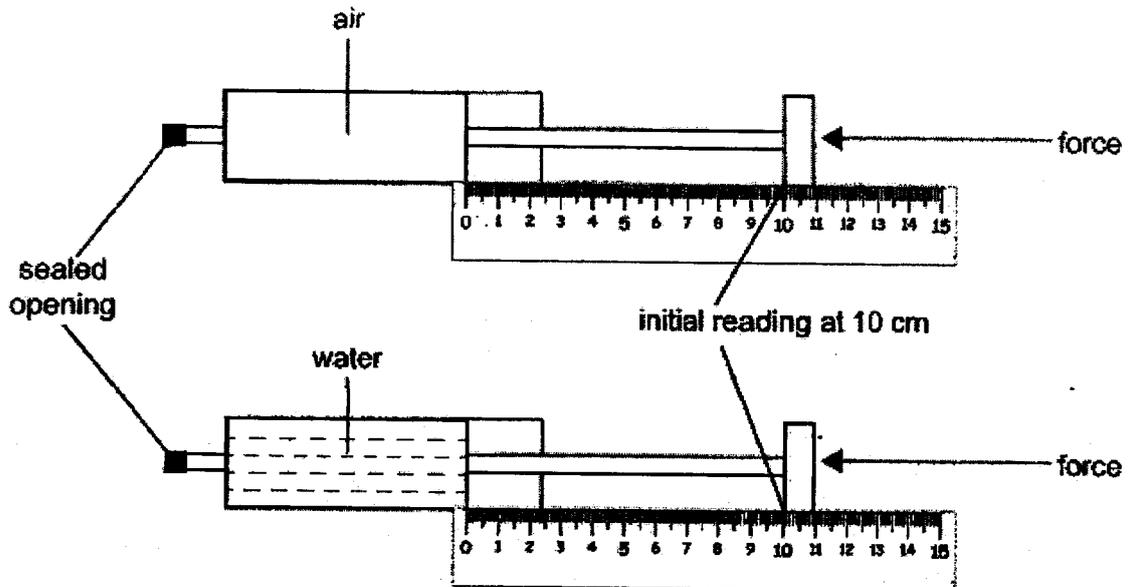

He then pushed each plunger as hard as he could until he could not push the plunger further. He recorded his observations in the table below.

Syringe with air (cm)	Syringe with water (cm)
7	?

- (i) What could the reading for the syringe filled with water be? (1m)

\_\_\_\_\_ cm

- (ii) Explain your answer in (i). (1m)

---



---

17. Tony wanted to find out how long it takes to heat three pots of water from room temperature to a temperature of  $60^{\circ}\text{C}$ . The pots are made of the same material and are of the same size as shown in the diagram below.

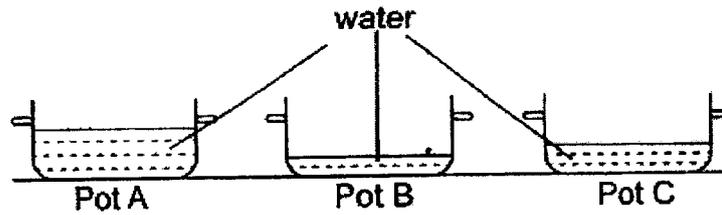

- (a) Put a tick ( $\checkmark$ ) to show the changed variable in the experiment above. (1m)

Variable	Changed variable
Size of the pot	
Amount of water in each pot	
Starting temperature of each pot of water	

- (b) Name the measuring instrument that Tony should use to measure the temperature of the water accurately. (1m)

---

- (c) The same amount of heat was used to heat each pot. Predict which pot of water, A, B or C, will take the shortest time to be heated to  $60^{\circ}\text{C}$ . Explain your answer. (1m)

---



---

- (d) Tony turned off the heat and left the pots of water on the table for six hours. What would be the temperature of the water after six hours? (1m)

---

**End of Paper**  
**Please check your answer.**

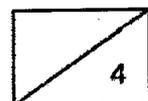

**SCHOOL : RED SWASTIKA PRIMARY SCHOOL**

**LEVEL : PRIMARY 4**

**SUBJECT : SCIENCE**

**TERM : TEST 1 2023**

**CONTACT :**

---

Q1	Q2	Q3	Q4	Q5	Q6	Q7	Q8	Q9	Q10
2	3	2	4	2	4	3	1	4	3

Q11	Q12	Q13	Q14
4	4	2	3

Q15)	<p>a) i) Insect M has a three-stage life cycle but Insect N has a four-stage life cycle.</p> <p>ii) A grasshopper.</p> <p>b) i) A → C → B → D</p> <p>ii) Stages B and D because at these two stages, they have leaves and leaves collect sunlight to take food.</p>
Q16)	<p>a) A: shadow B: air C: water D: rock</p> <p>b) i) 10cm</p> <p>ii) water cannot be compressed.</p>
Q17)	<p>a) Amount of water in each pot</p> <p>b) data longer</p> <p>c) Pot B as it has the least amount of water for heat to be transferred do it.</p> <p>d) Room temperature.</p>

