

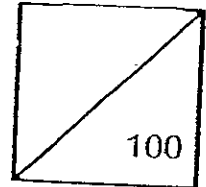

Rosyth School
Second Semestral Assessment for 2008
SCIENCE
Primary 4



Name: _____

Total
Marks:

Class: Pr _____

Register No. _____

Duration: 1 h 45 min

Date: 23rd October 2008

Parent's Signature: _____

Instructions to Pupils:

1. Do not open the booklets until you are told to do so.
2. Follow all instructions carefully.
3. This paper consists of 2 booklets, Booklet A and Booklet B.
4. For questions 1 to 30 in Booklet A, shade the correct ovals on the Optical Answer Sheet (OAS) provided using a 2B pencil.
5. For questions 31 to 46, give your answers in the spaces given in the Booklet B.

	Maximum	Marks Obtained
Booklet A	60 marks	
Booklet B	40 marks	
Total	100 marks	

* This booklet consists of _____ pages .

This paper is not to be reproduced in part or whole without the permission of the Principal.

Booklet A (60 MARKS)

For each question from 1 to 30, four options are given. One of them is the correct answer. Make your choice (1, 2, 3 or 4). **Shade the correct oval (1, 2, 3 or 4) on the Optical Answer Sheet.**

1. Look at the diagram below.

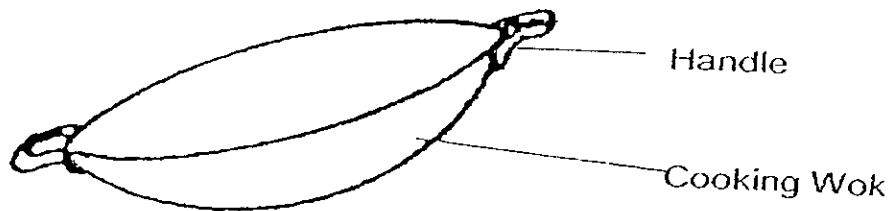

What materials are suitable for making the handle and cooking wok respectively?

- A: Wood
- B: Plastic
- C: Rubber
- D: Metal

- (1) A and B only
- (3) A and D only

- (2) A and C only
- (4) B and C only

2. The flowchart below shows the properties of some materials.

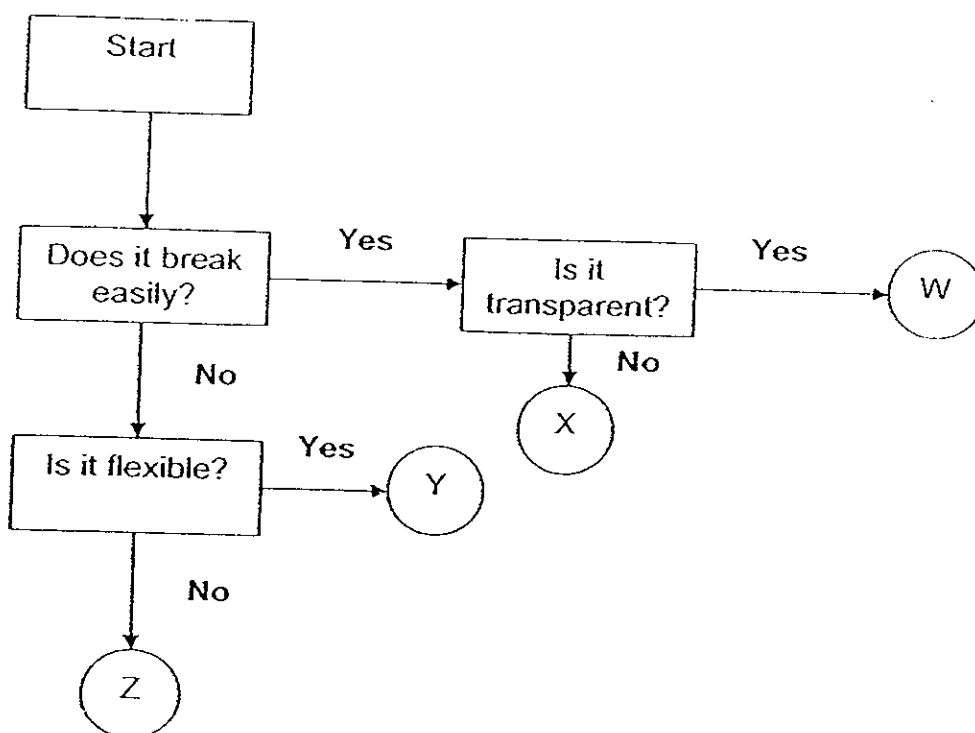

Which of the following materials would W, X, Y and Z most likely represent?

	W	X	Y	Z
(1)	Glass	Porcelain	Rubber	Wood
(2)	Glass	Plastic	Porcelain	Wood
(3)	Porcelain	Wood	Glass	Rubber
(4)	Rubber	Porcelain	Wood	Glass

4. Below is a picture of a window. Window panes are usually made of glass.

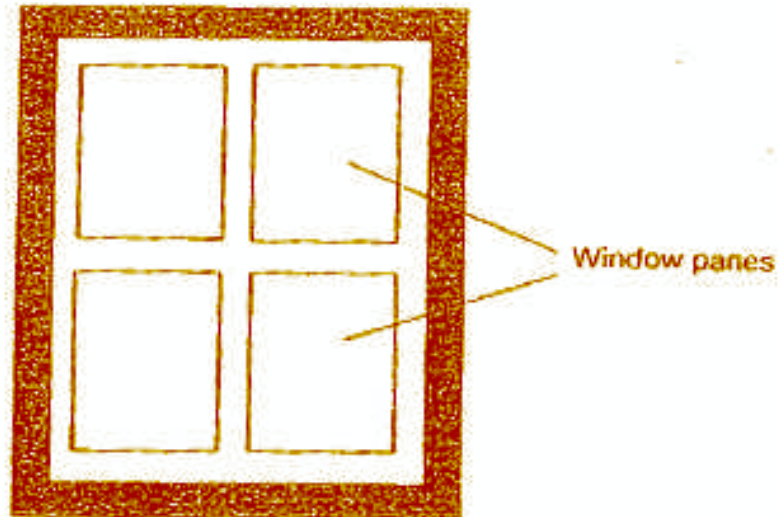

Why is the glass chosen for making window panes?

- A: Glass is waterproof.
- B: Glass is non-magnetic.
- C: Glass is a good conductor of heat.
- D: Glass allows light to pass through it.

- | | |
|---------------------|---------------------|
| (1) A and D only | (2) C and D only |
| (3) A, B and C only | (4) B, C and D only |

5. Which one of these animals have young that do not look like their parents when they are hatched?

- | | |
|-----------------|---------------|
| (1) Cat | (2) Frog |
| (3) Grasshopper | (4) Cockroach |

6. Study the four life cycles given. Which of the following shows the correct order of stages in the life cycle of an insect?

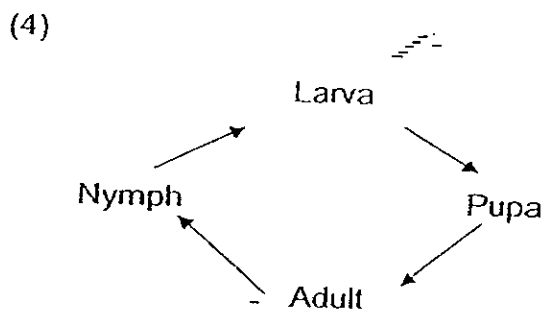
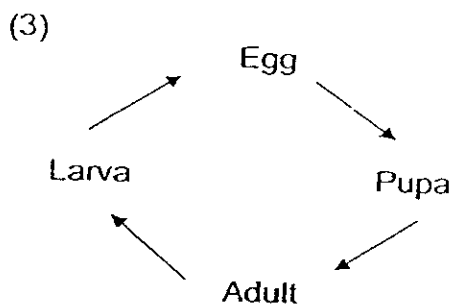
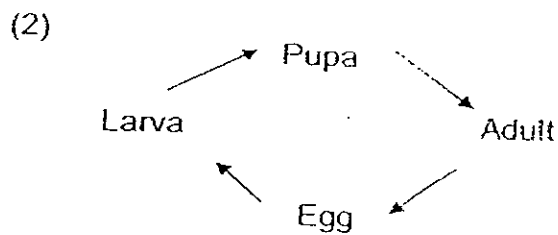
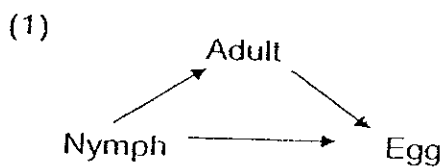

2

7. In which stage of the life cycle of a butterfly does moulting take place?

- (1) Egg
- (3) Pupa

- (2) Larva
- (4) Adult

2

The graph below shows the number of days of each stage in the life cycle of an insect. Please use it to answer questions 8 and 9.

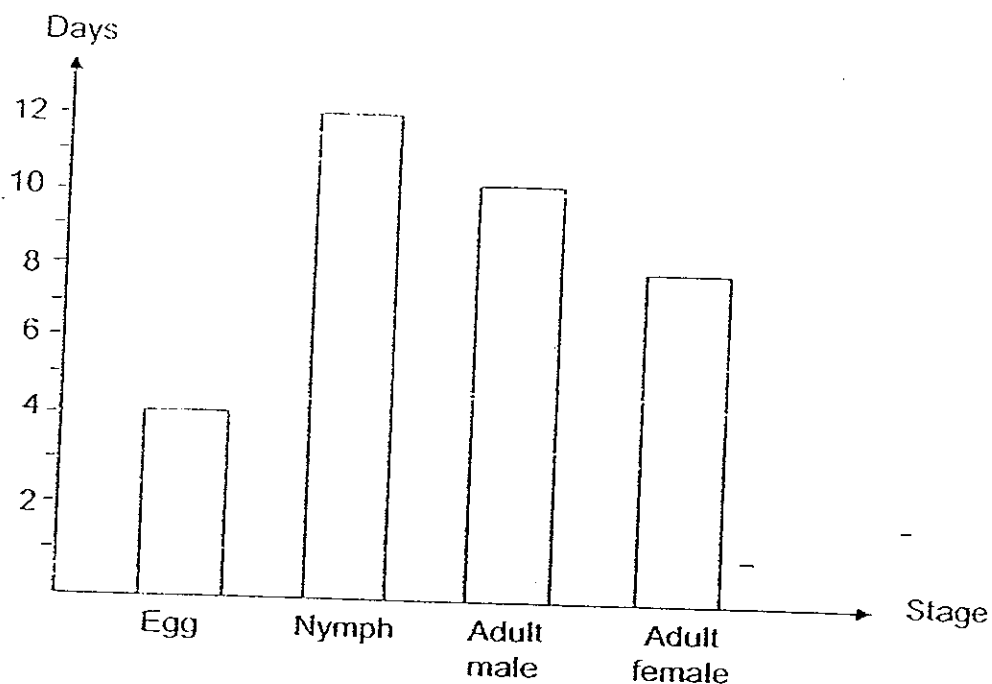

8. Which animals' life cycle can be represented by the graph above?
- | | |
|---------------|---------------------|
| (1) butterfly | (2) grasshopper |
| (3) mosquito | (4) mealworm beetle |
9. How many days would the insect take to become an adult after the egg is hatched?
- | | |
|-------------|-------------|
| (1) 6 days | (2) 8 days |
| (3) 10 days | (4) 12 days |
10. Mei Ling wanted to find out if temperature of water would affect germination of seeds. Which of the following variables must she keep the same for a fair experiment?
- | | |
|-------------------------|--|
| A: Temperature of water | |
| B: Amount of water | |
| C: Number of seeds | |
| D: Type of seeds | |
- | | |
|---------------------|-------------------|
| (1) A and B only | (2) C and D only |
| (3) B, C and D only | (4) A, B, C and D |

11. Gerald set up an experiment as shown in the diagram below. At the end of his experiment, he observed that the seeds grew into seedlings in some containers but not in others.

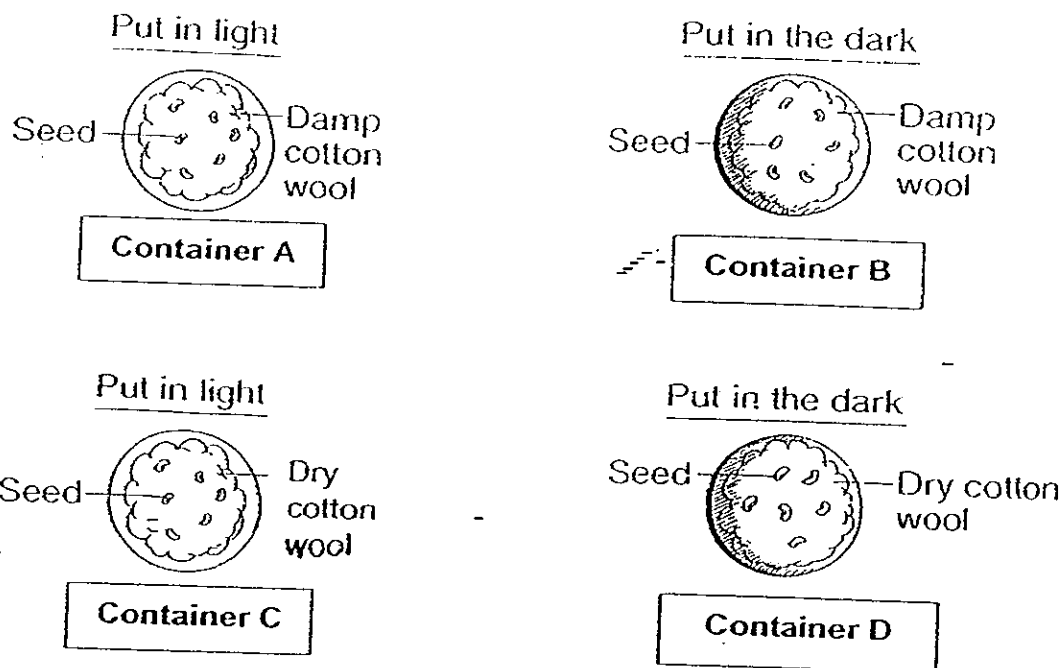

Which containers would have seeds growing into seedlings?

- (1) A and B only
 (2) A and C only
 (3) A, B and C only
 (4) B, C and D
12. The diagram below shows a seedling.

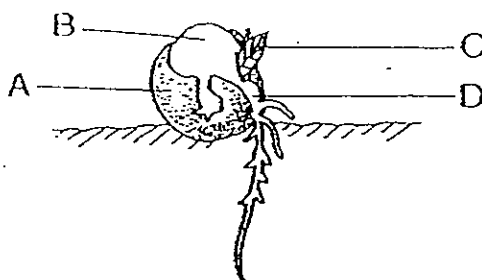

Which part provides food for the seedling?

- (1) A
 (2) B
 (3) C
 (4) D

13. Three objects K, L and M are placed on different weighing scales as shown below.

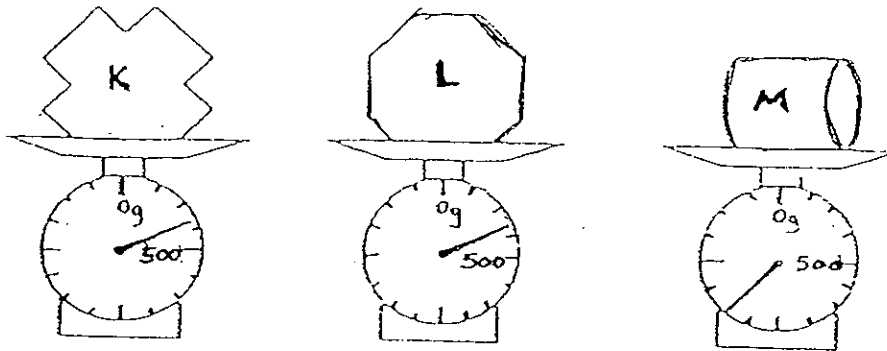

Which of the following deduction(s) can be made about the objects?

- A: M has a greater mass than K.
- B: K, L and M have the same volume.
- C: K and L have the same mass and volume.

- (1) A only
- (2) C only
- (3) B and C only
- (4) A, B and C

14. Which one of the following is a matter?

- (1) cloud
- (2) shadow
- (3) light
- (4) sound

15. The diagram shows two beakers, X and Y. Beaker X contains small stones and Beaker Y contains water up to the 30ml-mark.

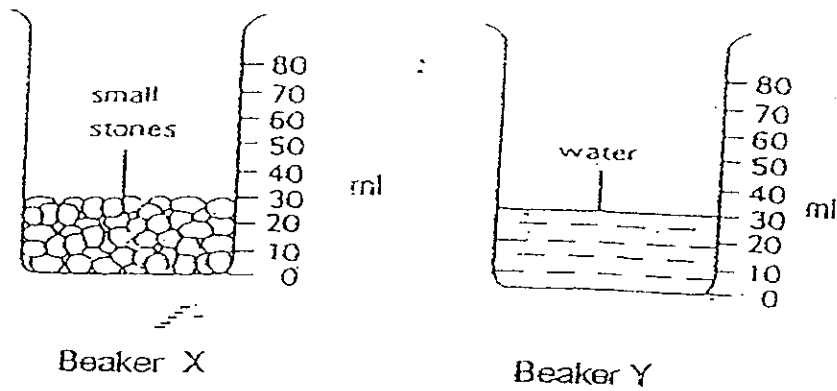

The water in Beaker Y is then poured into Beaker X. Which drawing shows the content of Beaker X after the water from Beaker Y has been poured into it after some time?

(1)

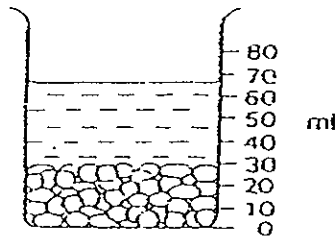

(2)

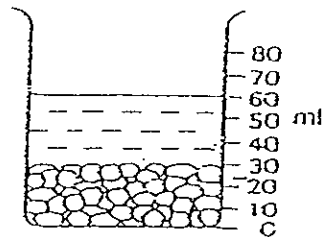

(3)

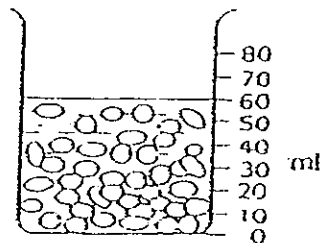

(4)

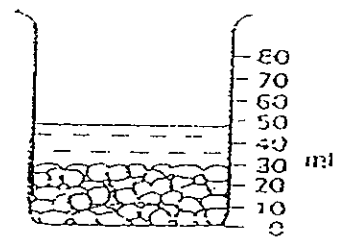

18. A glass of cold orange juice is put into a basin of tap water as shown in the diagram below.

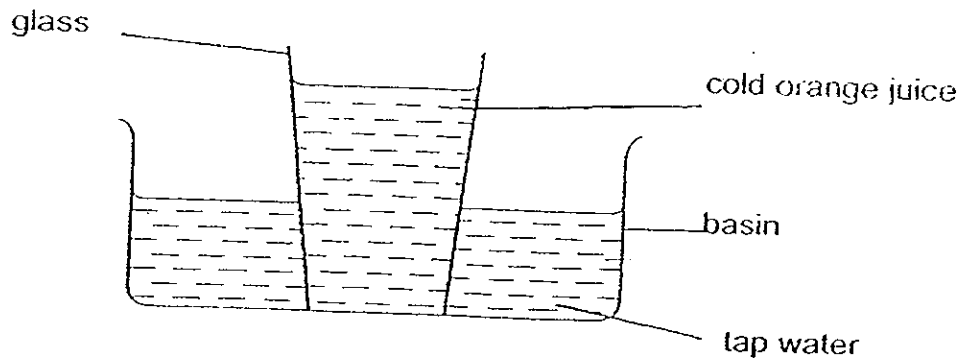

Why does the tap water in the basin become cold after some time?

- (1) The heat from the orange juice is transferred to the tap water.
 - (2) The heat from the tap water is transferred to the orange juice.
 - (3) The heat from the tap water is transferred to the surrounding air.
 - (4) The heat from the orange juice is transferred to the surrounding air.
19. Gloria set up the experiment as shown below. When the torch is lighted, a shadow is cast on the screen.

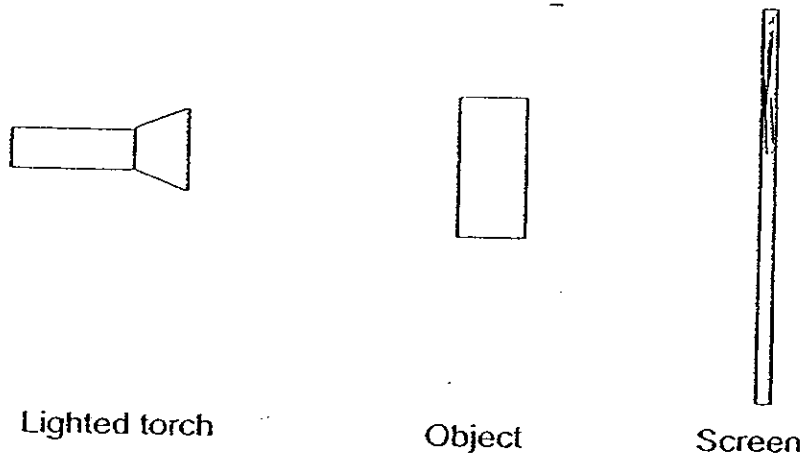

What must she do to make the shadow bigger?

- A: Move the lighted torch towards the object
 - B: Move the object further from the screen
 - C: Move the screen towards the object
- (1) A only
 - (2) C only
 - (3) A and B only
 - (4) B and C only

20. The diagram below shows three objects that are placed in a dark room. When the torchlight is shone on the objects, a shadow is cast on the screen as shown.

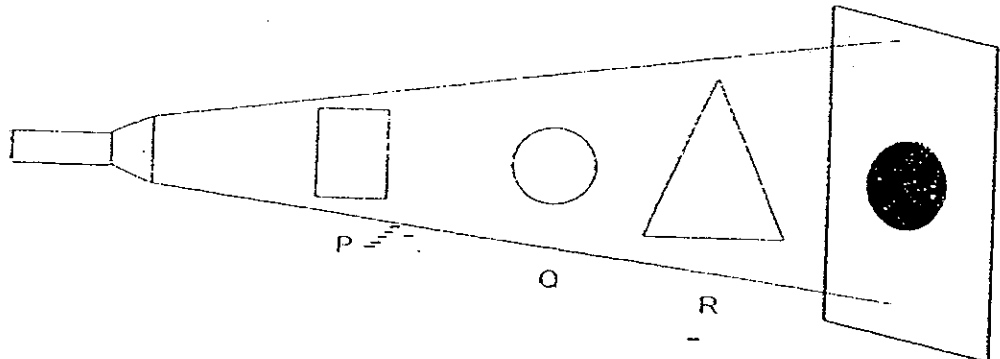

What materials could P, Q and R be made of?

	P	Q	R
(1)	Clear plastic	Frosted glass	Iron
(2)	Cardboard	Rubber	Clear glass
(3)	Clear glass	Clear plastic	Cardboard
(4)	Clear glass	Rubber	Clear plastic

21. Fanny wanted to find out how length of shadow changes at different times in a day. She observed a pole and drew the shadows P, Q, and R at 3 different times.

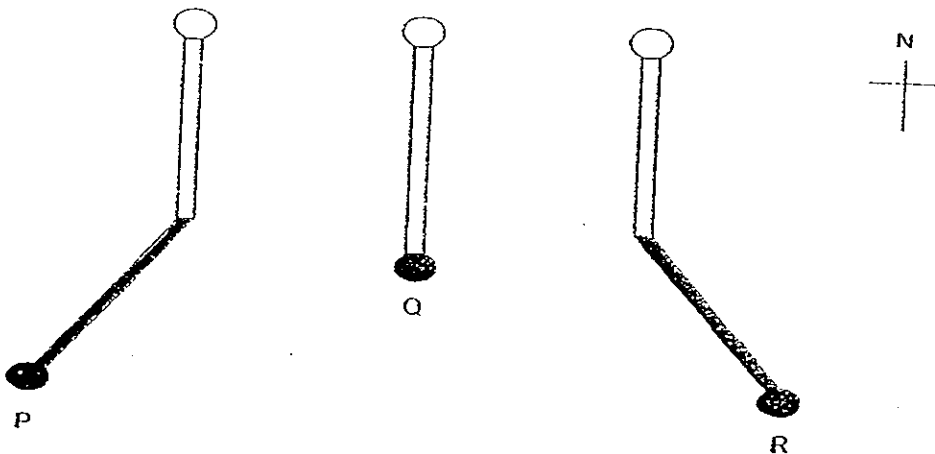

At which times did Fanny draw the shadows P, Q and R?

	P	Q	R
(1)	8 am	9 am	10am
(2)	9 am	4 pm	11am
(3)	9 am	noon	4 pm
(4)	4 pm	noon	9 am

22. John placed an eraser as shown in the diagram below.

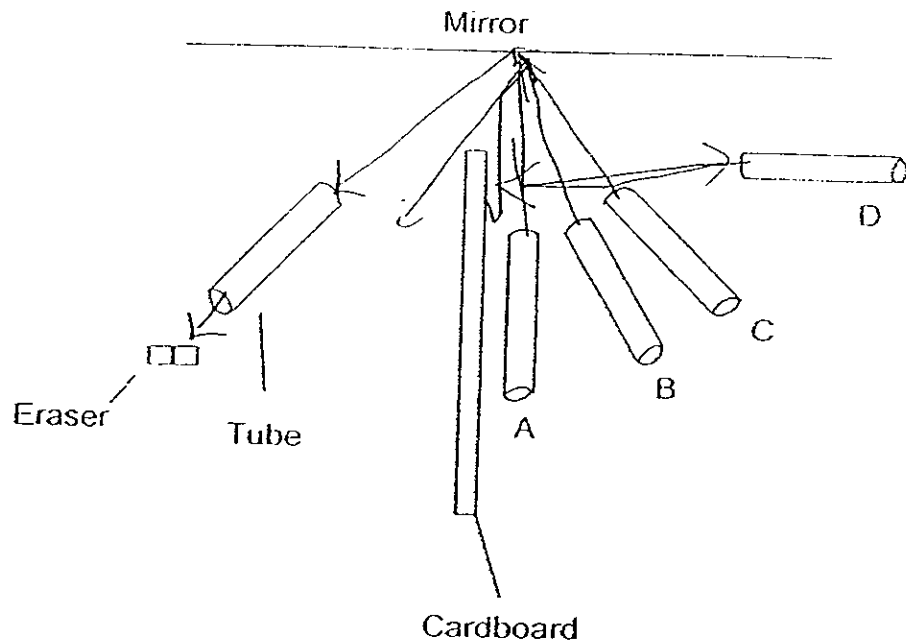

Which tube A, B, C and D would enable you to see the eraser?

- | | |
|------------------|------------------|
| (1) A only | (2) C only |
| (3) B and D only | (4) C and D only |

23. Four steel rods of equal thickness but different lengths were heated to the temperatures indicated in the diagrams below. Which one of the steel rods has the least heat?

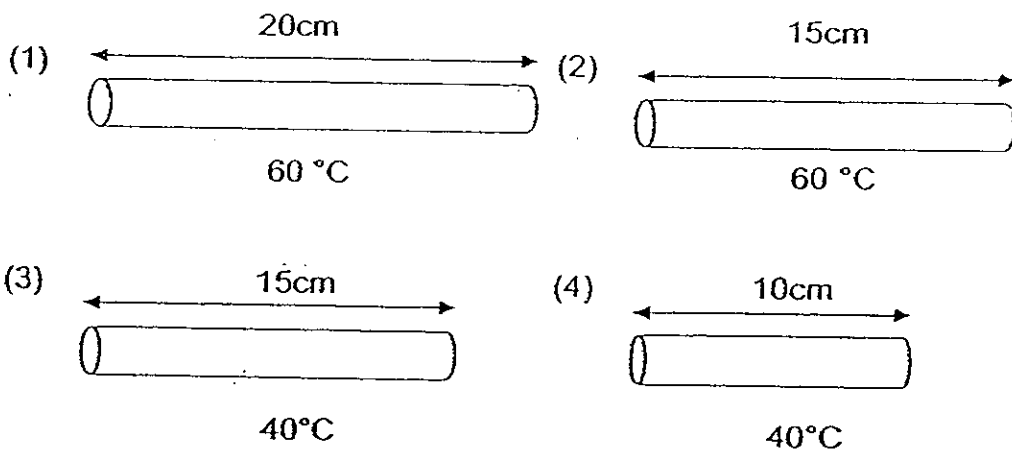

24. The temperatures of two beakers of water A and B were taken. The hot water and the cold water were poured into Beaker C. The temperature of Beaker C was taken after some time. Study the table below and choose the correct readings taken of the temperatures in the three different beakers.



What is the likely temperatures of beakers A, B and C respectively?

	Beaker A	Beaker B	Beaker C
(1)	70°C	20°C	70°C
(2)	85°C	10°C	95°C
(3)	75°C	15°C	45°C
(4)	80°C	20°C	20°C

25. Study the graph below.

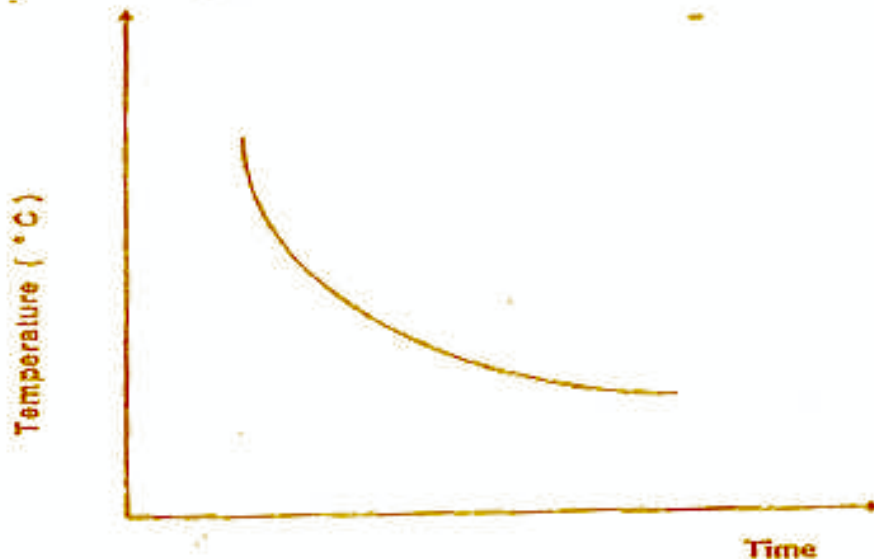

Which one of the following examples will show a similar pattern to the line graph as shown above?

- (1) A pot of soup being warmed.
- (2) An ice cube taken out from the freezer.
- (3) A cup of coffee being heated in a microwave oven.
- (4) A bowl of freshly cooked prawn noodles left on the table.

26. Four boxes of the same size and mass, A, B, C and D, had the same starting temperature of 30°C . They were then heated for 10 minutes and their new temperatures were recorded in the graph below.

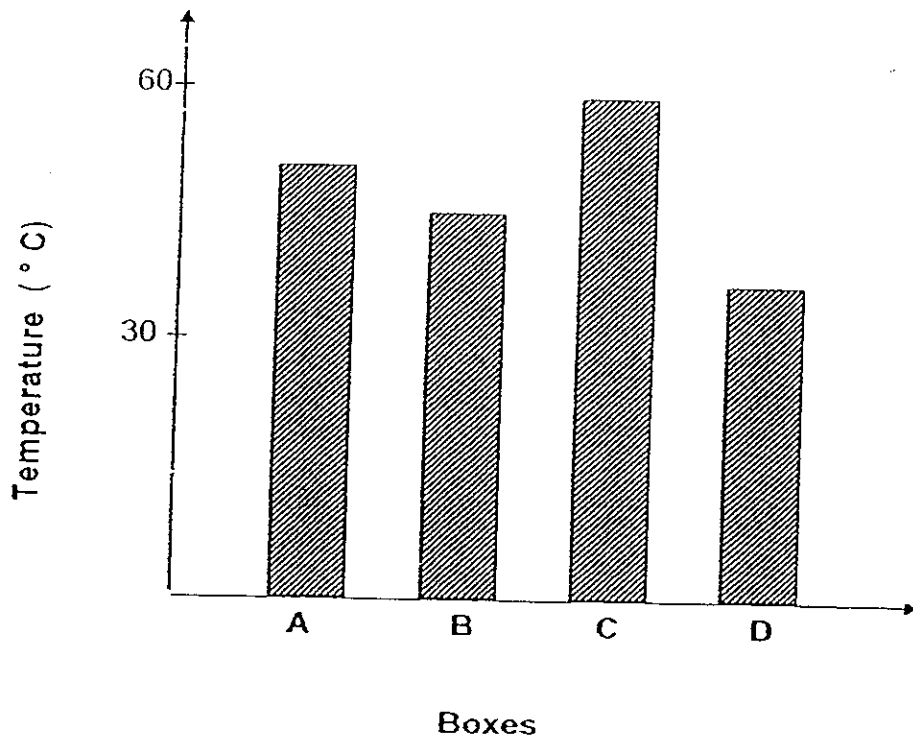

Which box, A, B, C or D, is the best to keep ice from melting?

- | | |
|-------|-------|
| (1) A | (2) B |
| (3) C | (4) D |

27. Jeya prepared two conical flasks, X and Y, as shown below.

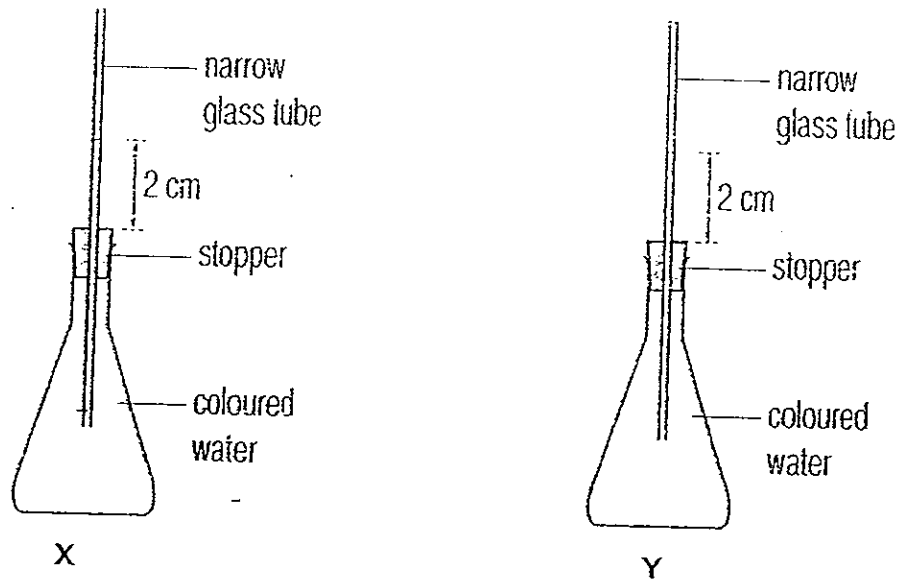

Later, he placed the two conical flasks in beakers of hot water and ice for the same time. He made his observations as shown below.

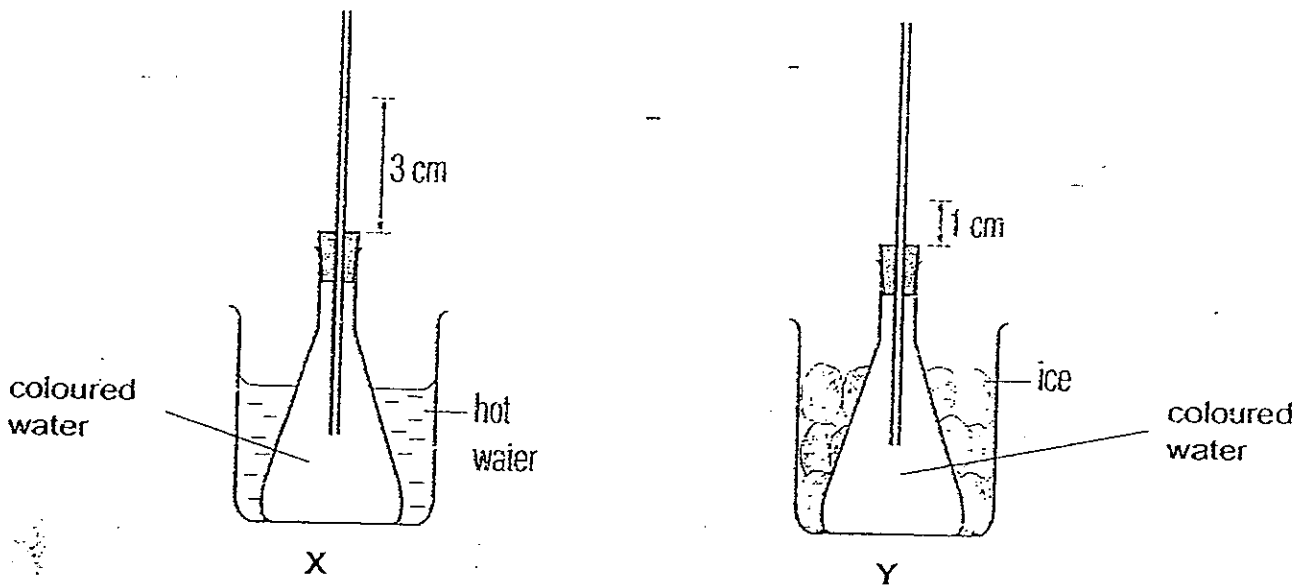

Which of the following would lose heat after the two conical flasks were placed in the beakers?

- A: Hot water ✓
- B: Ice
- C: Coloured water in flask X
- D: Coloured water in flask Y

- (1) A and B only
- (3) A and D only

- (2) C and D only
- (4) B and C only

28. In some places, telephone wires are hung on poles above the ground.

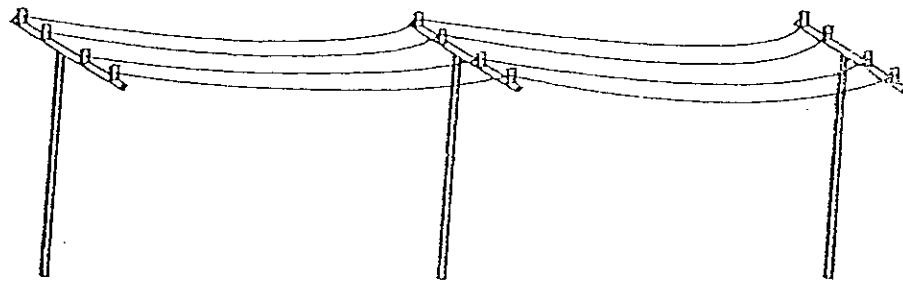

Why are the wires hung loosely between the poles?

- (1) It is to allow for expansion on hot days.
- (2) It is to allow for contraction on cold nights. ✓
- (3) It is to allow for movement on windy days.
- (4) It is to allow birds to rest on the wires all the time.

29. A U-shaped magnet is lowered completely into a box of pins.

Which one of the following diagrams shows what it looks like when it is lifted from the box of pins?

(1)

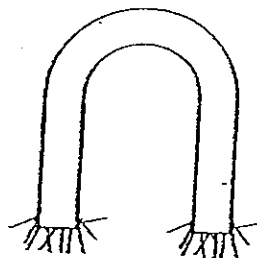

(2)

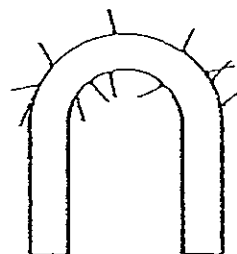

(3)

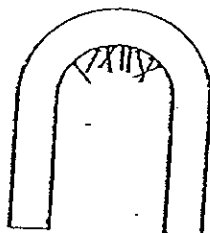

(4)

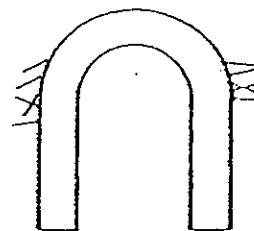

30. Study the diagram below. A piece of X is placed between the U-shaped magnet and the paper clip. The paper clip remains floating.

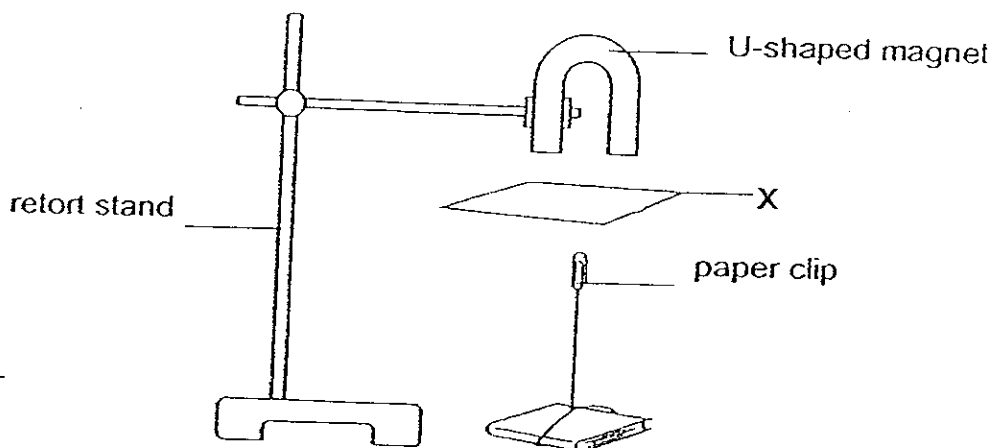

Name the material X could be made of.

- A: Glass
- B: Iron
- C: Steel
- D: Plastic

- (1) A and B only
- (3) B and C only

- (2) A and D only
- (4) C and D only

End of Booklet A

Booklet B (40 MARKS)

For questions 31 to 46, write your answers in this booklet.

31. The diagram below show the life cycles of two animals, Gino and Dino.

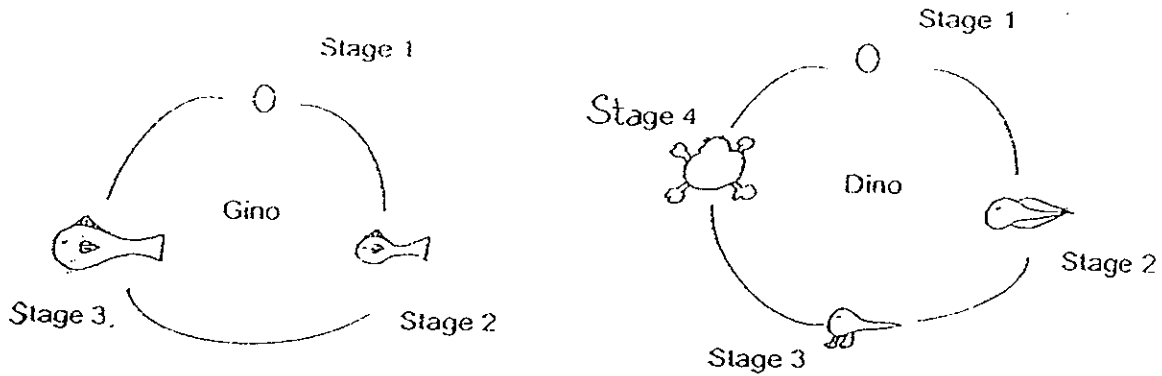

(a) Based on the diagram above, state one similarity between the two life cycles. (1mark)

(b) Based on the diagram above, state one difference between the two life cycles. (1mark)

(c) Which animal is more likely to spend part of its life on land? Give a reason for your answer. (2marks)



Rosyth School
Second Semestral Assessment for 2008
SCIENCE
Primary 4

Name: _____

Total
Marks:

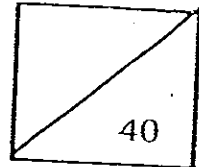

Class: Pr _____ Register No. _____

Duration: 1 h 45 min

Date: 23rd October 2008

Parent's Signature: _____

Booklet B

Instructions to Pupils:

1. For questions 31 to 46, give your answers in the spaces given in this Booklet B.

* This booklet consists of 15 pages. (1A to 33)

This paper is not to be reproduced in part or whole without the permission of the Principal.

32. Study the diagram below.

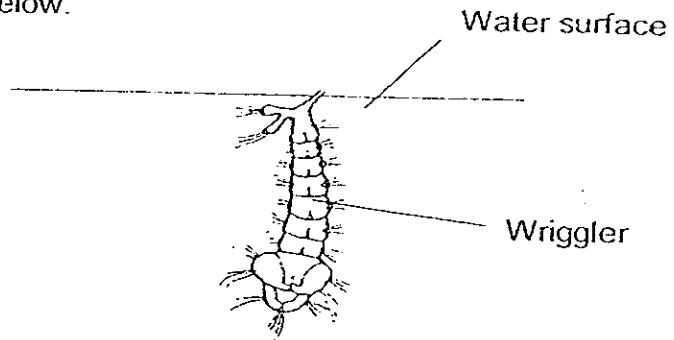

(a) Why is the wiggler positioned in such a way in the pond? (1mark)

(b) Wrigglers grow into mosquitoes. What is one way in which they can be eliminated before they turn into mosquitoes? (1mark)

33. Hadi prepared two set-ups as shown below.

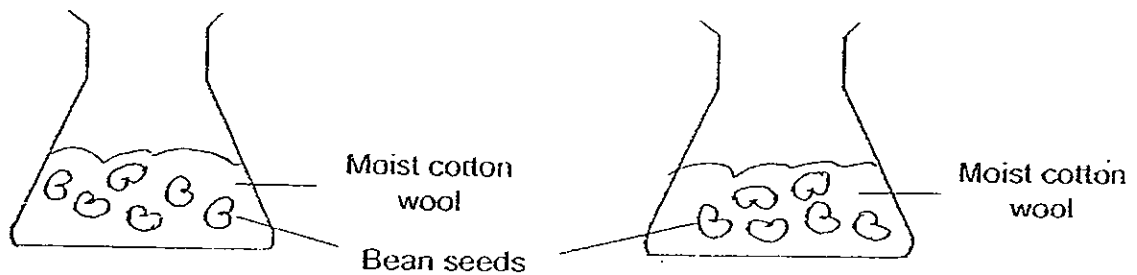

(a) Would Hadi be able to use the two set-ups to find out if water is required for germination to take place? Explain why. (1mark)

(b) What should he do if he wanted to find out if light is required for germination to take place? (1mark)

34. Mrs Tan grew tomato plants in her garden. She measured the height of the plants over a period of time.

She recorded the results in the table as shown below.

Number of weeks	5	10	15	20
Average height of plants	30	45	50	50

She used the results to draw the graph.

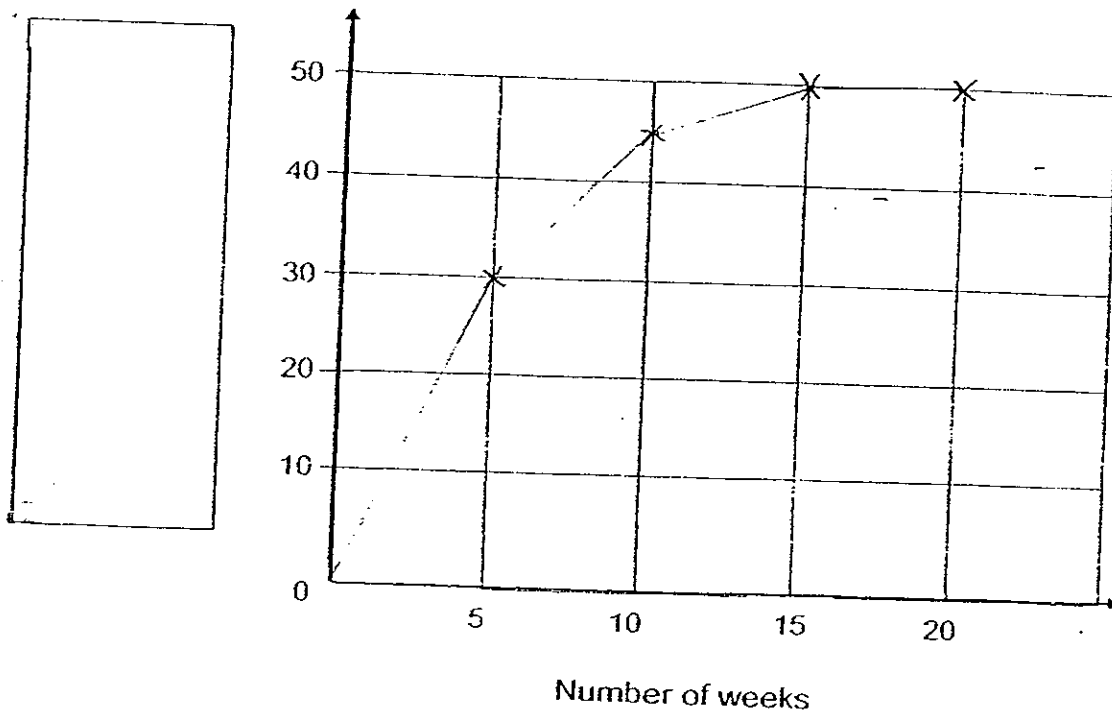

- (a) Label the y-axis in the given box. (1mark)
- (b) Plot the points with crosses (x) and draw the line graph. (2marks)

35. Tom and Peter set up the following experiment. A 100-ml glass was filled with water and inverted into a basin of water as shown below.

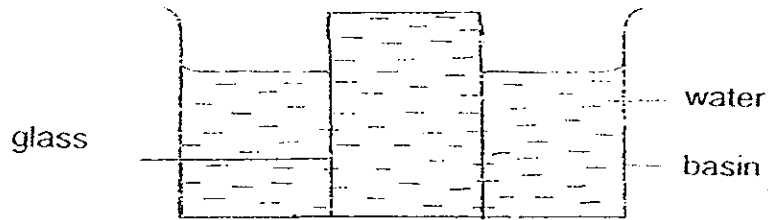

First Tom used a straw to blow some air into the glass. The height of the water was recorded. Then Peter blew some air into the glass and the height of water was recorded. The results were recorded in the table below.

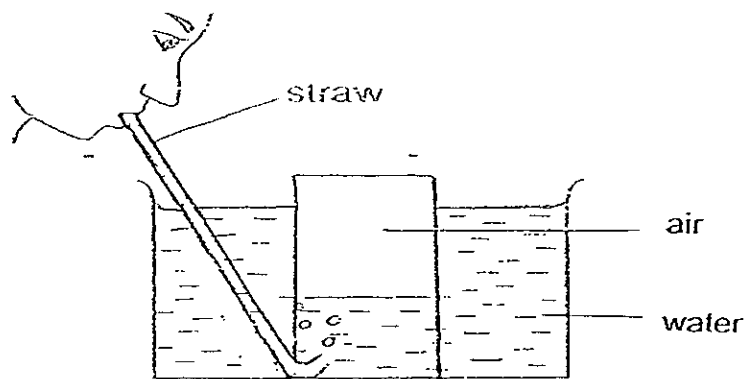

	Height of water in the glass (cm)
At the start of experiment	100
After Tom had blown	70
After Peter had blown	30

- (a) Why has the height of water in the glass decreased? (1 mark)

- (b) Who has blown more air? (1 mark)

36. Using the set-up below, Samy carried out an investigation to find the volume of four different objects, P, Q, R and S using the set-up as shown below.

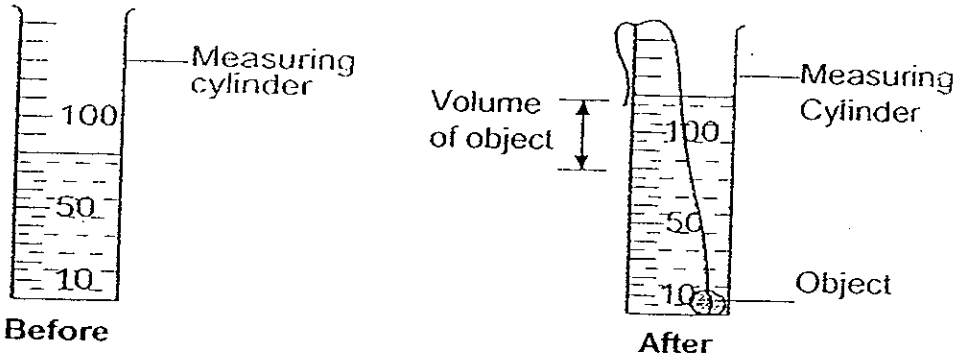

He put object P into the measuring cylinder and noted the new volume of water. He then recorded the volume of the object. He removed object P and repeated the steps for each of the other 3 objects. Finally, he plotted the graph below to show the volume of the objects for each of the 4 objects.

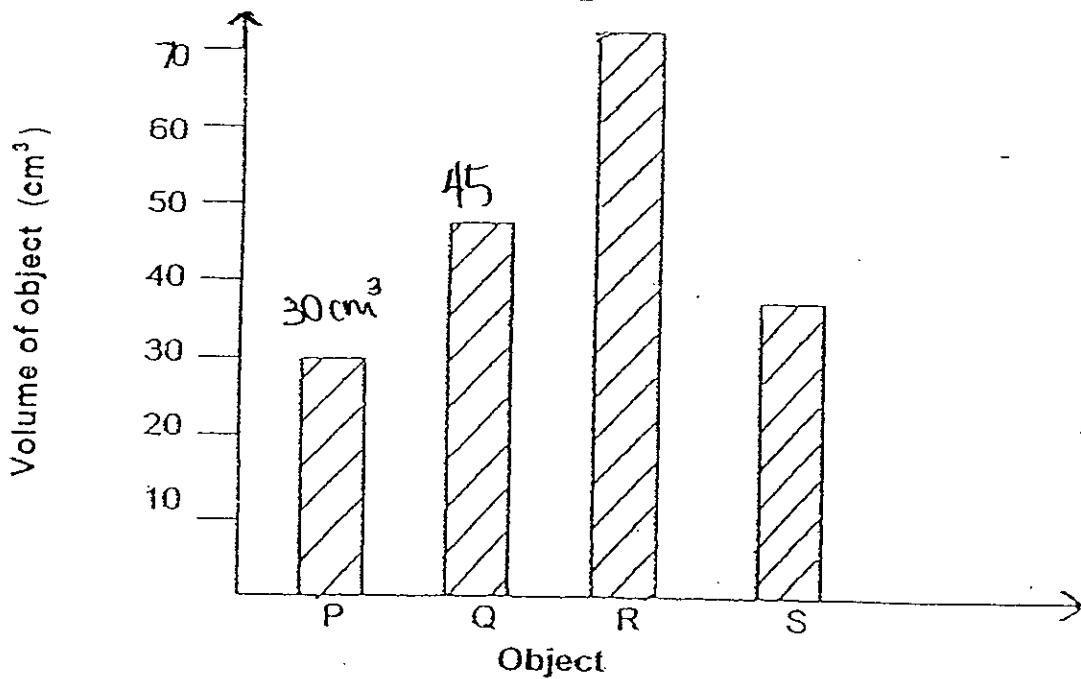

- (a) Arrange the objects P, Q, R and S in order, beginning with the one with the smallest volume (1 mark)

- (b) If object P is put into a measuring cylinder containing 50cm³ of water, what would be the new water level in the measuring cylinder? (1 mark)

37. Study the diagram below carefully.

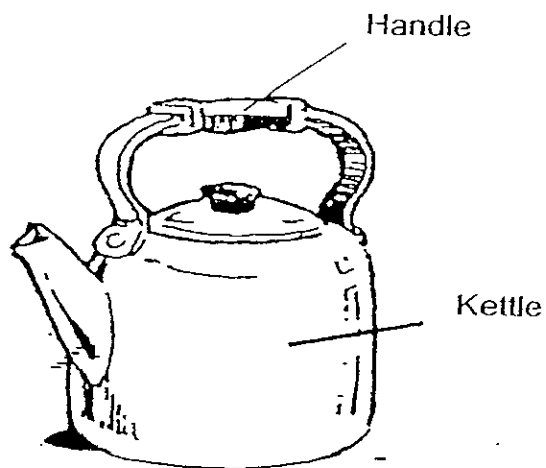

- (a) The handle of a kettle is not made of metal. Name the material that the handle is made of. (1mark)

- (b) Give a reason for your answer in (a). (1mark)

38. Gina wanted to conduct an experiment to show how quickly an ice cube melts is affected by the temperature of the water used. She set up 4 beakers, A, B, C and D of similar size, as shown below.

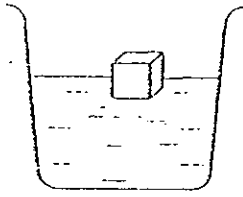
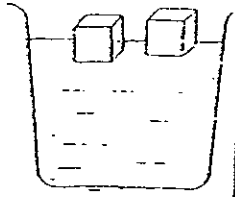
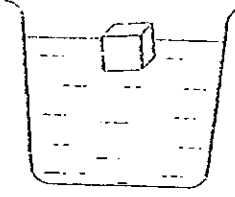
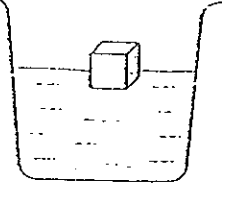
A	B	C	D
			
<p>Temperature of water 50°C</p>	<p>Temperature of water 90°C</p>	<p>Temperature of water 50°C</p>	<p>Temperature of water 90°C</p>

- (a) Gina chose to use Beakers A and B for her experiment. Explain why she made the wrong choice. (2 marks)

- (b) Identify the following variables in this ^{experiment} investigation. (2 marks)

(i) Variable changed :

(ii) Variable to be kept the same :

39. Three basins of water, A, B and C, are at different temperatures. Nicholas dips his right hand into Basin A and his left hand into Basin C. Five minutes later, he dips both of his hands into Basin B. He finds that the water in Basin B feels warm to his right hand but feels cold to his left hand.

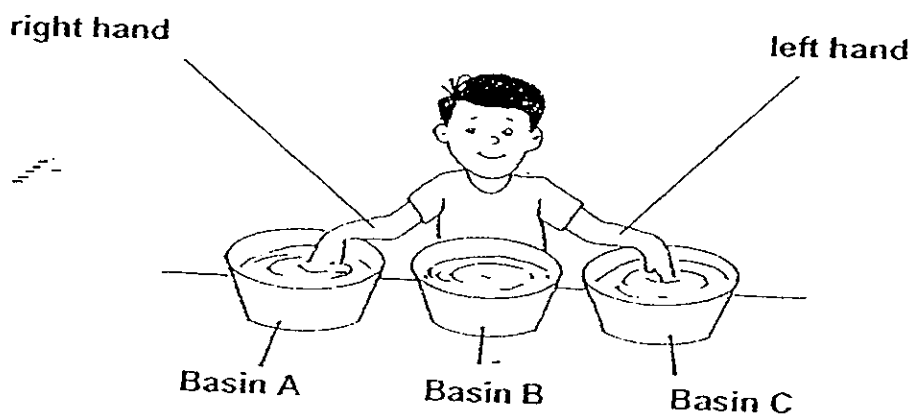

- (a) Based on Nicholas' observation, match the basin with the temperature readings given below. (1 mark)

Temperature of water ($^{\circ}$ C)	Basin
0	
25	B
60	

- (b) Though the temperature of the water in Basin B was constant at 25° C, it felt warm to Nicholas' right hand and cold to his left hand. What does this tell you about our sense of touch to measure temperature? (1 mark)

40. Study the diagram below. Beaker A containing 500ml of water and Beaker B containing 200ml of water at room temperature were heated until the water boiled.

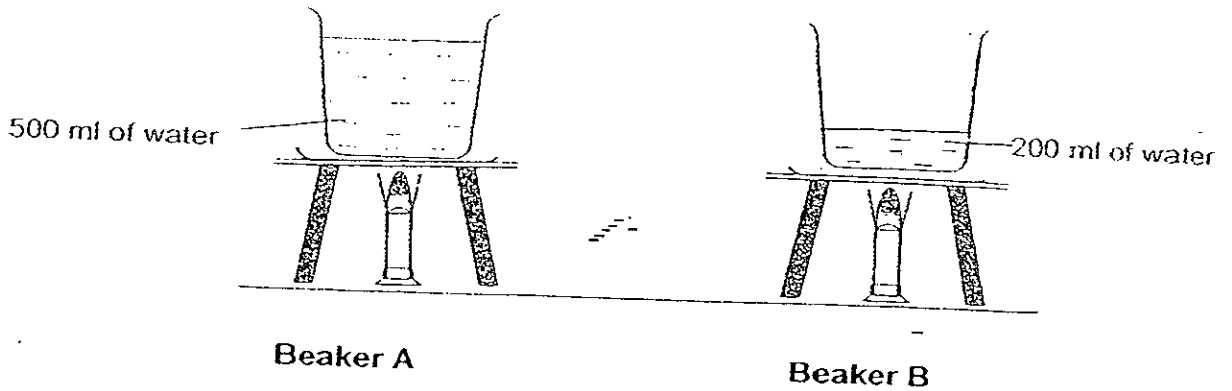

- (a) Which beaker of water, A or B, will boil faster? (1 mark)
-

The graph for Beaker A was plotted to show how the temperature changed with time.

- (b) Draw the graph for Beaker B to show how the water in Beaker B reached 100 °C. (1 mark)

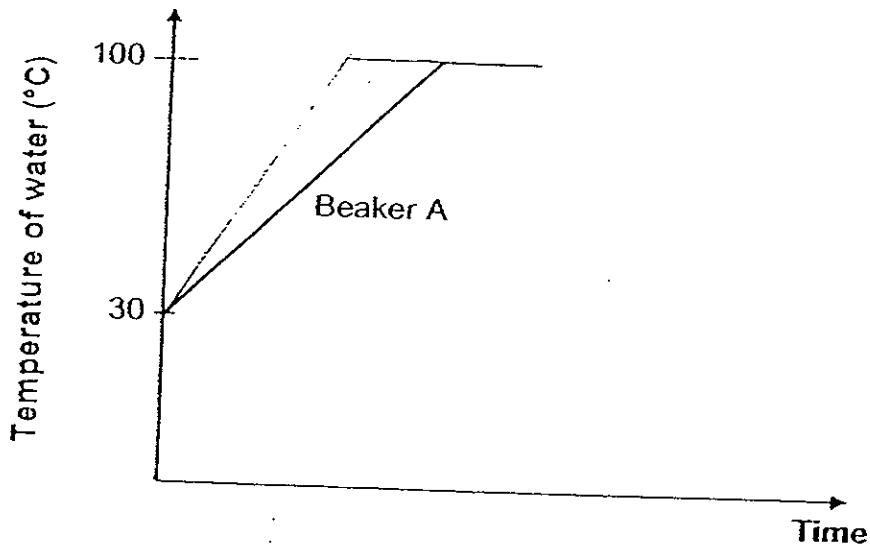

- (c) Explain why Beaker A has more heat than Beaker B at 100°C? (1mark)
-
-

41. A metal mug and a glass were stuck together as shown in the diagram below.

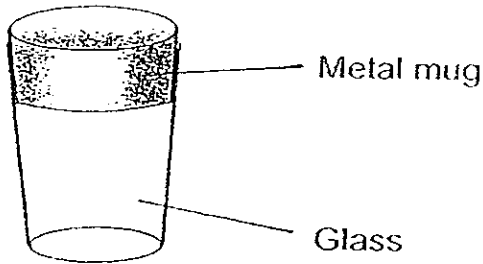

- Kenny tried pulling them apart but he could not separate the two containers. His mother provided him with some ice.
- (a) Using only what he was given, what could Kenny do to separate the two containers? (1 mark)

- (b) Explain how the two containers were separated. (1 mark)

42. Three thumbtacks, E, F, G, were fixed to the metal rod by using the same amount of wax. The metal rod was heated by a candle flame as shown below.

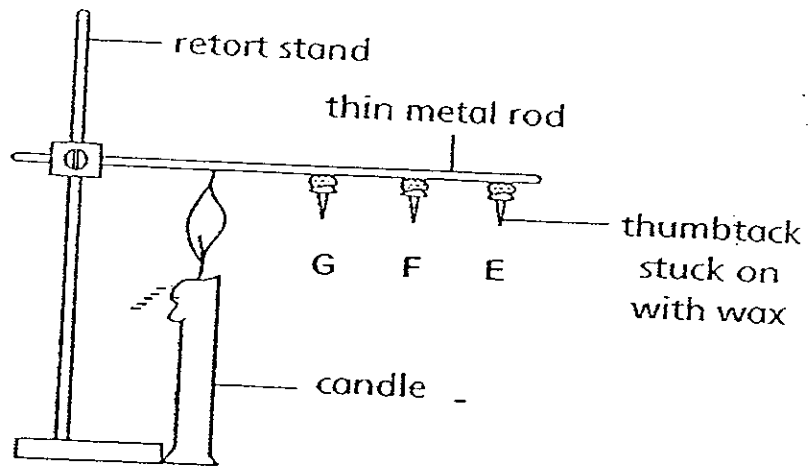

- (a) Which thumbtack would fall last? (1 mark)

- (b) What does this experiment show? (1 mark)

43. A torchlight from above was moved from position Q to position P and then to position R. A shadow was cast when the torchlight was switched on at all the three positions.

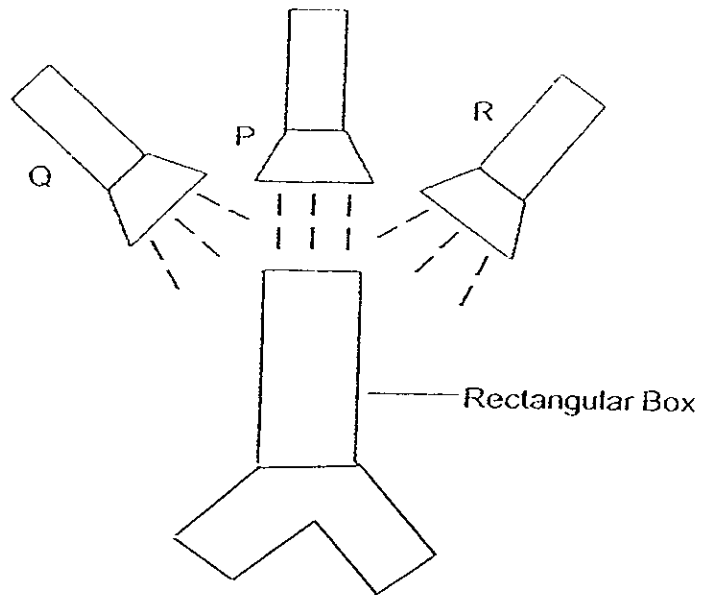

- (a) Describe what happens to the length of the shadow cast on the floor as the torchlight moves from position Q to P? (1mark)
-
-
- (b) Draw on the diagram to show where the shadows were cast when the torchlight was at position Q and position R. (2marks)

44. George set up an experiment as shown in the diagram below to find out how light helps us to see things.

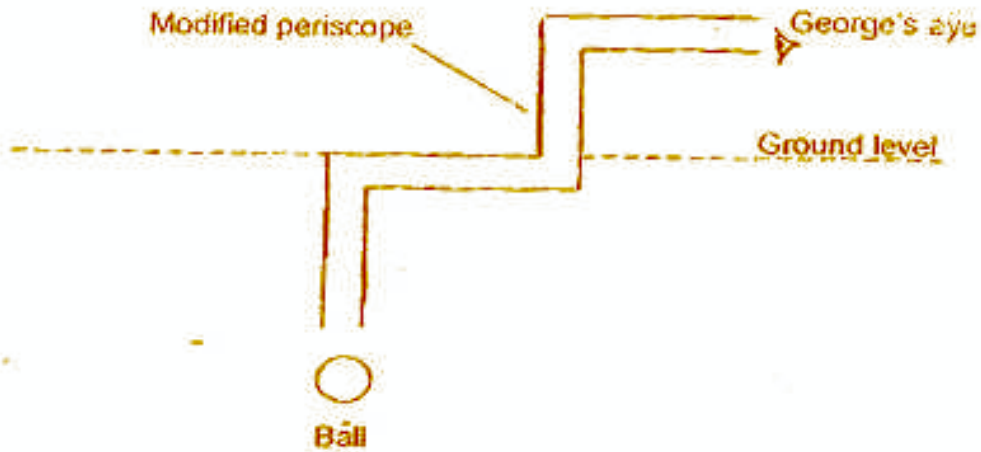

- (a) Draw mirrors in the modified periscope such that they allow George to see the ball. (1mark)
- (b) Draw the light rays which enable George to see the ball. Indicate the directions of the light using arrows in the figure above. (1mark)
- (c) Using the above diagram name an advantage of using this modified periscope. (1mark)

45. The diagram below shows three floating ring magnets on a pole.

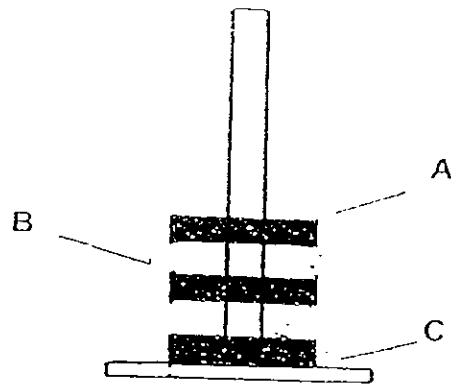

(a) Write either 'N-pole' or 'S-pole' in the blanks provided. (1 mark)
The North Pole has already been marked on C.

(i) A: _____

(ii) B: _____

(iii) C: North Pole

(b) What would happen if all the magnets were turned the other way so that the other poles of A, B and C, faced one another? (1 mark)

46. Study the diagram below.

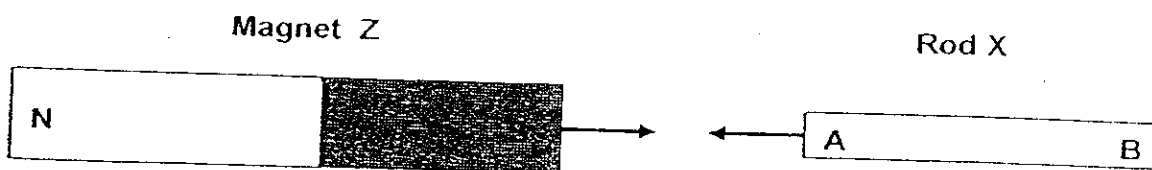

When Magnet Z is placed near rod X, part A and part B were attracted to the South Pole of the magnet.

Which of the following information is 'True', 'False' or 'Not Possible to Tell'? Put a tick (✓) in the appropriate columns. (2 marks)

	True	False	Not Possible To Tell
(a) Rod X is not a magnet			
(b) The North Pole of the magnet will definitely repel part B			
(c) Magnet Z is a weak magnet			
(d) Rod X is made of aluminium			

End of the paper

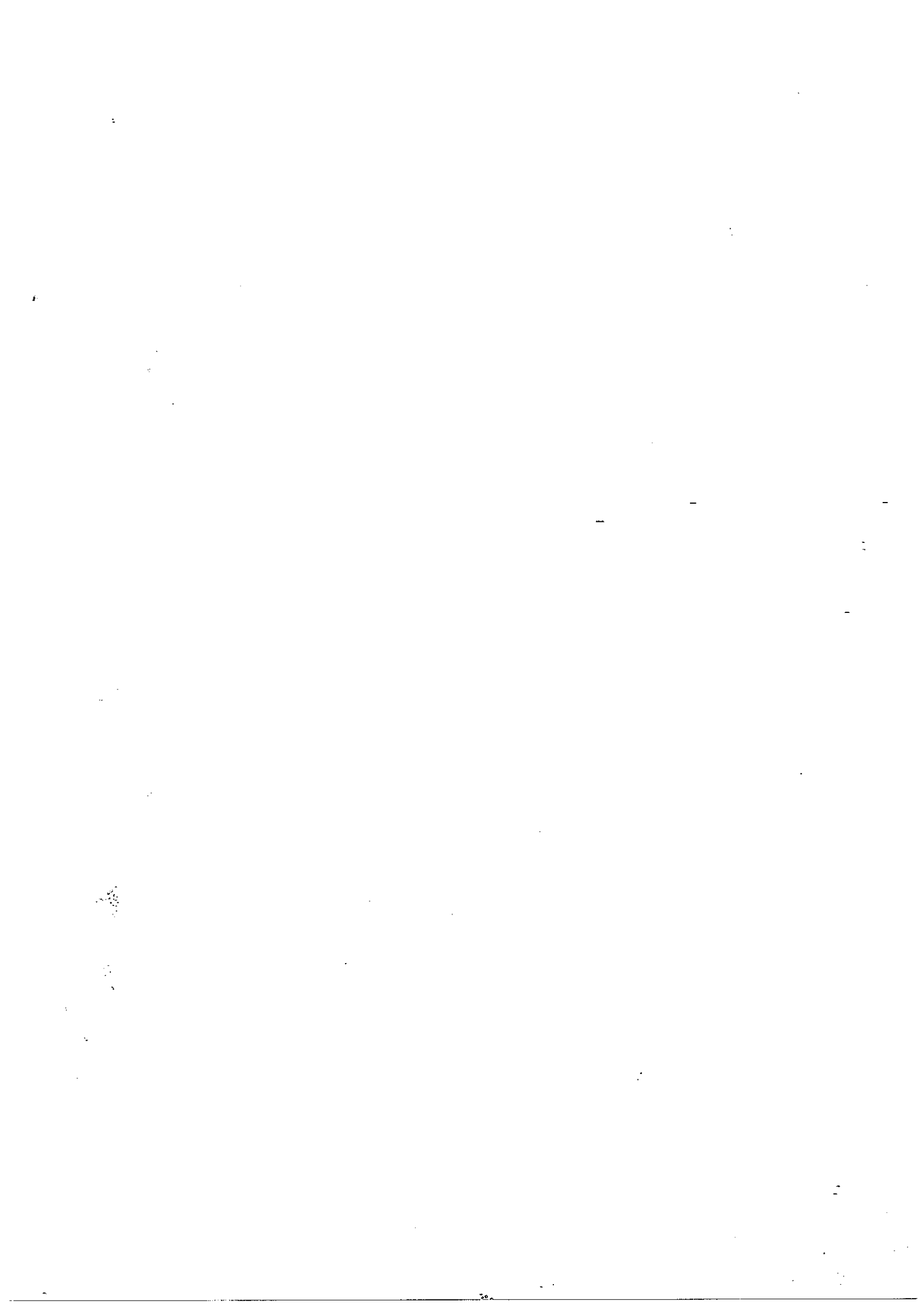

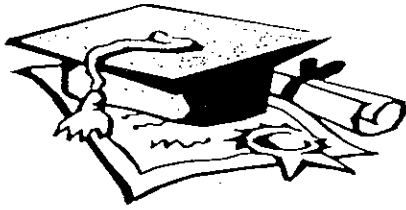

ANSWER SHEET

EXAM PAPER 2008

SCHOOL : ROSYTH PRIMARY SCHOOL
 SUBJECT : PRIMARY 4 SCIENCE

TERM : SA 2

Q1	Q2	Q3	Q4	Q5	Q6	Q7	Q8	Q9	Q10	Q11	Q12	Q13	Q14	Q15	Q16	Q17
3	1	3	1	2	2	2	2	4	3	1	2	1	1	4	1	4

Q18	Q19	Q20	Q21	Q22	Q23	Q24	Q25	Q26	Q27	Q28	Q29	Q30
2	3	4	3	2	4	3	4	4	3	2	1	2

31)a)Both lay eggs.

b)Gina has 3 stages while Dion has 4 stages of life cycle.

c)Dino is more likely to spend part of its life n land. It has developed legs and has no tail at the stage.

32)a)It can breathe through the breathing tube.

b)Spray oil on the water surface to prevent the wrigglers to breathe and they will die of lacking oxygen.

33)a)Hadi would not be able to find out if water is required for germination. The two set-up have water to germinate.

b)He should put one set-up in the light and the other in the dark.

34)a,b

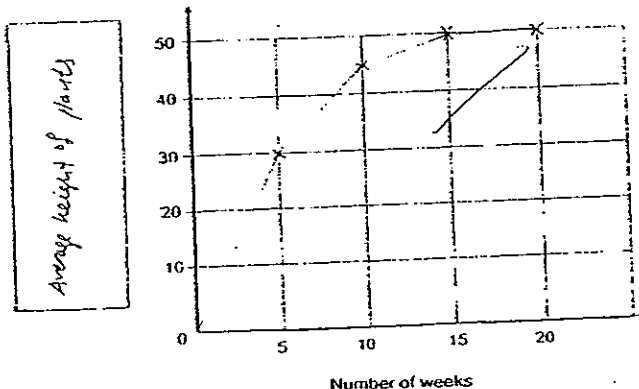

35)a) Air occupies space. The water had to flow out of the glass to give some space to the air.

b) Peter has blown more air.

36)a) P, S, Q, R

b) The new water level is 80cm³

37)a) The handle is made of wood.

b) Wood is a poor conductor of heat and when you touch the handle, it will not burn your hand.

38)a) The volume of water.

b) i) Temperature water.

c) Number of ice cubes.

39)a) 0=A 60=C

b) Our sense of touch is not accurate.

40)a) Beaker B.

b)

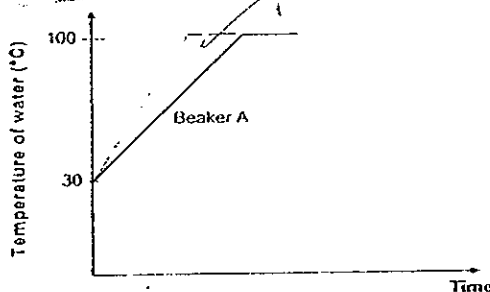

c) Beaker A has more water compared to Beaker B.

41)a) Put the ice in the mug.

b) The metal mug lost heat and contracted.

42)a)Thumbtack E.

b)This experiment shows that heat travels from a hotter place to a colder place.

43)a)The length of the shadow becomes shorter.

b)

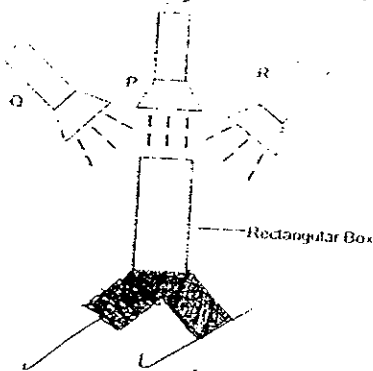

44)a),b

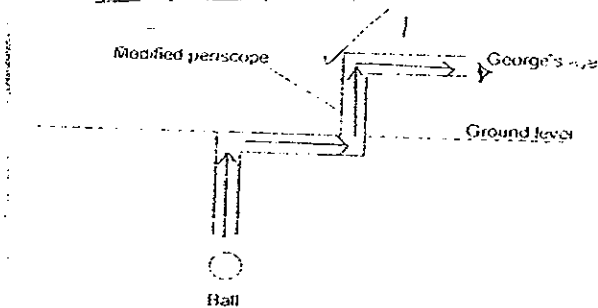

c)It allows you to see what is underground.

45)a)i)South ii)North

b)They will still repel to each other.

46)a)T b)F c)Not d)F