

**METHODIST GIRLS' SCHOOL (PRIMARY)**

**PRIMARY 4**

**FIRST SEMESTRAL ASSESSMENT 2008**

**SCIENCE**

**BOOKLET A**

**NAME:** \_\_\_\_\_ (      )

**CLASS:** \_\_\_\_\_

**Total time for Booklets A and B: 1 h 30 min.**

**DO NOT OPEN THIS BOOKLET UNTIL YOU ARE TOLD TO DO SO.  
FOLLOW ALL INSTRUCTIONS CAREFULLY.**

Section A : ( 30 x 2 marks )

For each question, four options are given. Choose the most suitable option and shade your answer in the Optical Answer Sheet (OAS) provided.

1. Study the classification chart below.

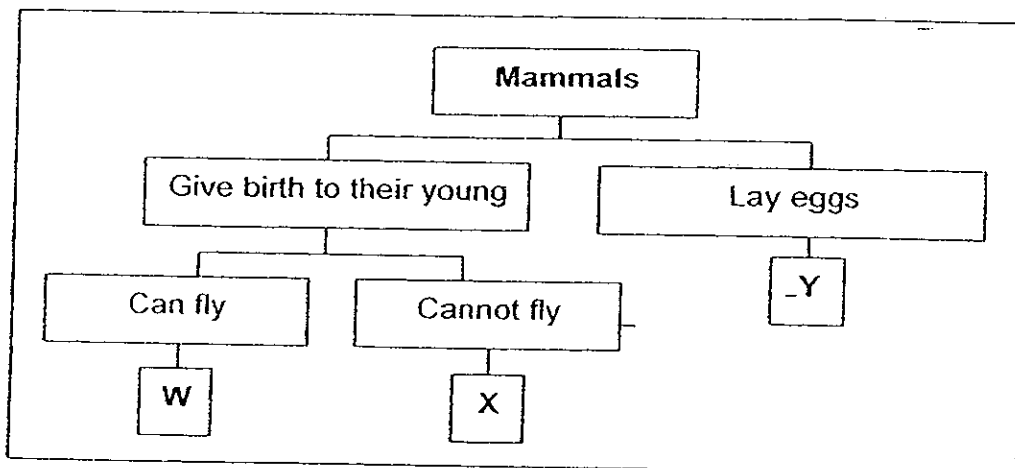





The following statements are made based on the classification chart above.

- A : W can fly but X cannot.  
B : W, X and Y are mammals.  
C : Y lays eggs but X gives birth to its young.  
D : Both W and Y can give birth to their young.

Which of the following statement/s is/are correct?

- (1) A only  
(2) A and B  
(3) A, B and C  
(4) A, B, C and D

2. Jenny wanted to find out how different fertilizers affect plant growth. She prepared 4 pots of seedlings as shown in the diagram below.

Pot A	Pot B	Pot C	Pot D
			
20g of fertilizer P 50 ml of water garden soil	50g of fertilizer P 50 ml of water sandy soil	20g of fertilizer Q 50 ml of water garden soil	50g of fertilizer Q 40 ml of water sandy soil

Which two pots of seedlings should Jenny use for the experiment?

- (1) Pots A and B
  - (2) Pots A and C
  - (3) Pots B and C
  - (4) Pots B and D
3. Felicia's plant was growing towards one side. She wanted her plant to grow upright. She then placed the plant in a black box with an opening and put it directly below a lamp as shown in the diagram below.

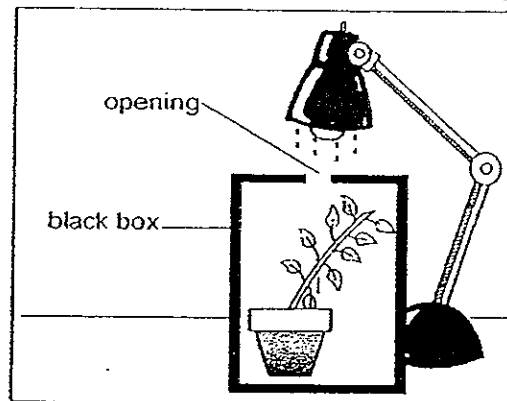

Which one of the following statements explains why Felicia's experiment would work?

- (1) The plant would respond to the light.
- (2) The plant needed light to make food.
- (3) The plant would grow faster under the light.
- (4) The plant would obtain warmth from the light.

4. The diagram below shows the life cycle of a mosquito.

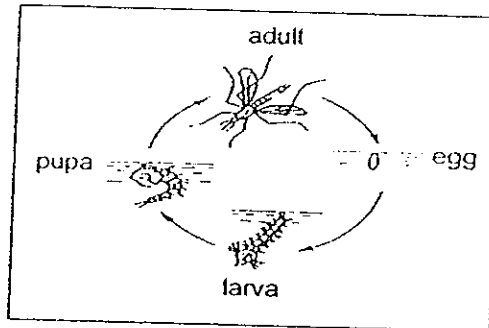

At which stage of the life cycle is the mosquito most harmful to man?

- (1) egg
- (2) larva
- (3) pupa
- (4) adult

For question 5 and 6, refer to the graph shown below.

The graph below shows the number of days in each stage of the life cycle of an insect.

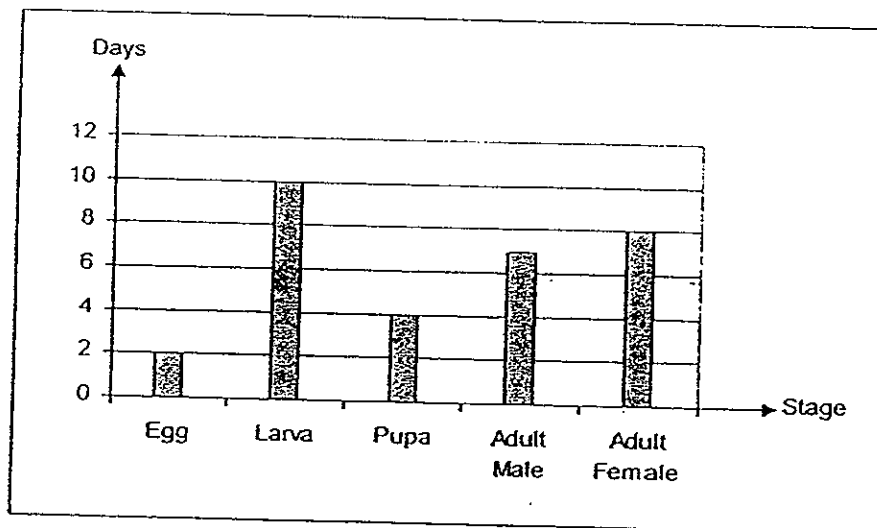

5. How many stages are there in the life cycle of the insect above?

- (1) 5
- (2) 2
- (3) 3
- (4) 4

6. How many days would the insect take to become a female adult after the egg is hatched?

- (1) ~~14~~ days
- (2) ~~16~~ days
- (3) ~~24~~ days
- (4) ~~29~~ days

7. The diagram below shows the bone structure of our elbow.

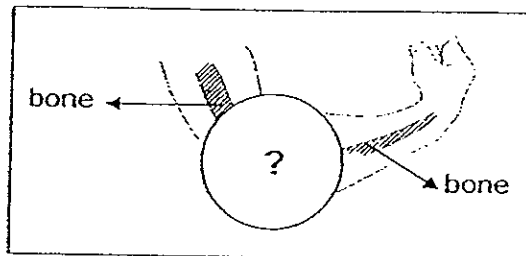

Which one of the following diagrams correctly shows how the bones should be drawn?

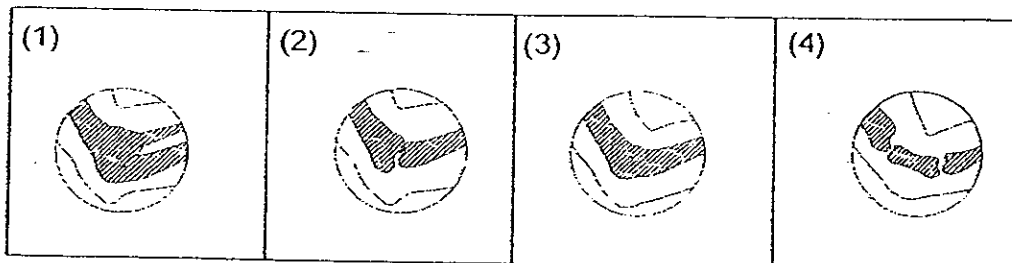

8. Which of the following statements incorrectly compare the difference between air that is inhaled and air that is exhaled by a healthy person?

- A : Inhaled air is warmer than exhaled air.
- B : Inhaled air contains less oxygen than exhaled air.
- C : Inhaled air has more dust particles than exhaled air.

- (1) A and B
- (2) A and C
- (3) B and C
- (4) A, B and C

9. Which part of the digestive system does most of the digested food enter the circulatory system?

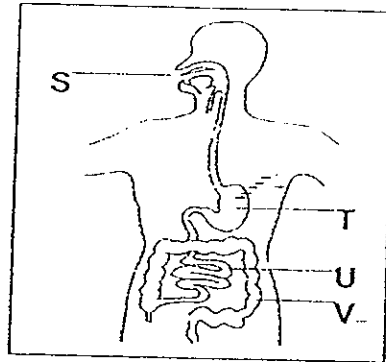

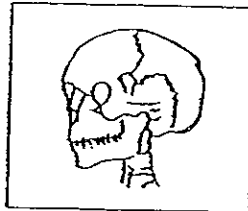

- (1) S
- (2) T
- (3) U
- (4) V

10. Look at the diagram below.

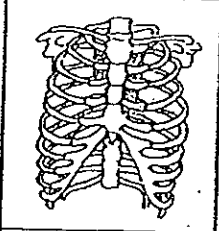
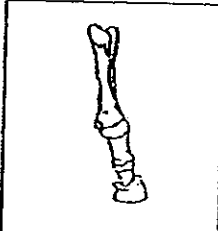
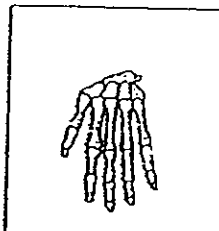

Which of the following bone/bones has/have the same protective function as the skull shown in the diagram above?

			
rib cage ✓	leg bone	finger bone	pelvic bone ✓

- (1) rib cage only
- (2) rib cage and finger bone
- (3) pelvic bone and rib cage
- (4) leg bone and pelvic bone

11. The graph below shows how a piece of plain biscuit was digested in the different parts of the digestive system in the human body.

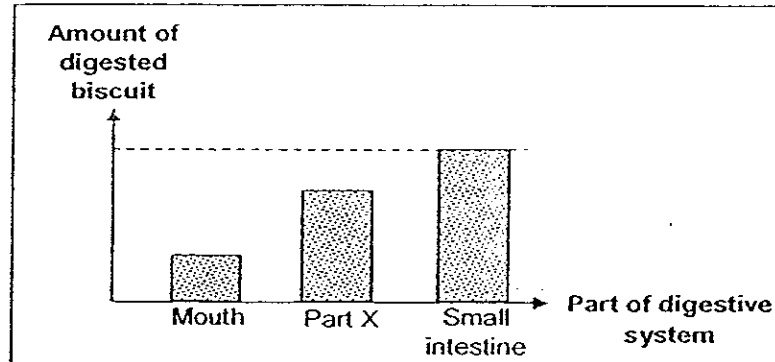

Which part of the body is part X?

- (1) gullet
  - (2) rectum
  - (3) stomach
  - (4) large intestine
12. Four similar glass jars A, B, C and D were filled with water. A water snail was then placed in Jar A and Jar C only. Some hydrilla were added into Jar A, B and C. All the jars were then covered with wooden covers as shown in the set up below. They were then placed under sunlight for a day.

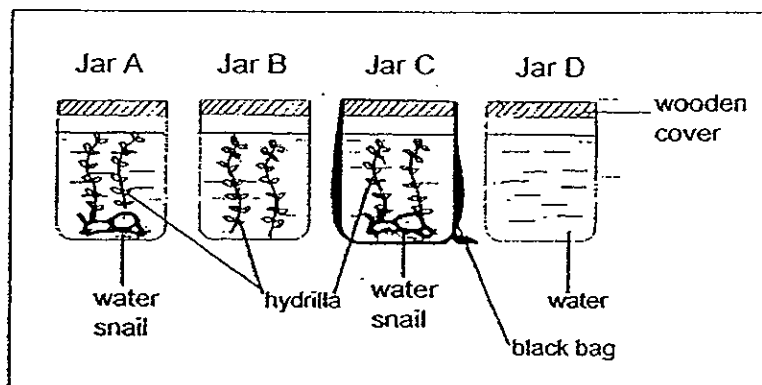

In which jar would the amount of carbon dioxide be the highest?

- (1) Jar A
- (2) Jar B
- (3) Jar C
- (4) Jar D

13. A real plant and a plastic plant were each placed into similar containers filled with 300ml of water. A layer of oil was poured into each container to prevent the water from evaporating as shown in the diagram below.

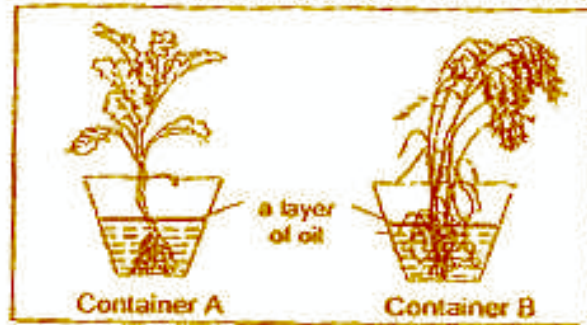

- The volume of water in each container was measured at the beginning of the set-up and a week later. Which of the following sets of measurements is most likely to be correct?

	Volume of water (ml) a week later	
	Container A	Container B
(1)	260 ml	250 ml
(2)	300 ml	300 ml
(3)	250 ml	300 ml
(4)	300 ml	310 ml

14. The diagram below shows a certain process.



What is the process known as?

- (1) Moulting
- (2) Fertilisation
- (3) Respiration
- (4) Photosynthesis



15. John wanted to find out how temperature would affect the germination of bean seeds. He soaked 10 red bean seeds in water at different temperatures for ten hours. He then counted the number of seeds that germinated. The graph below shows his results.

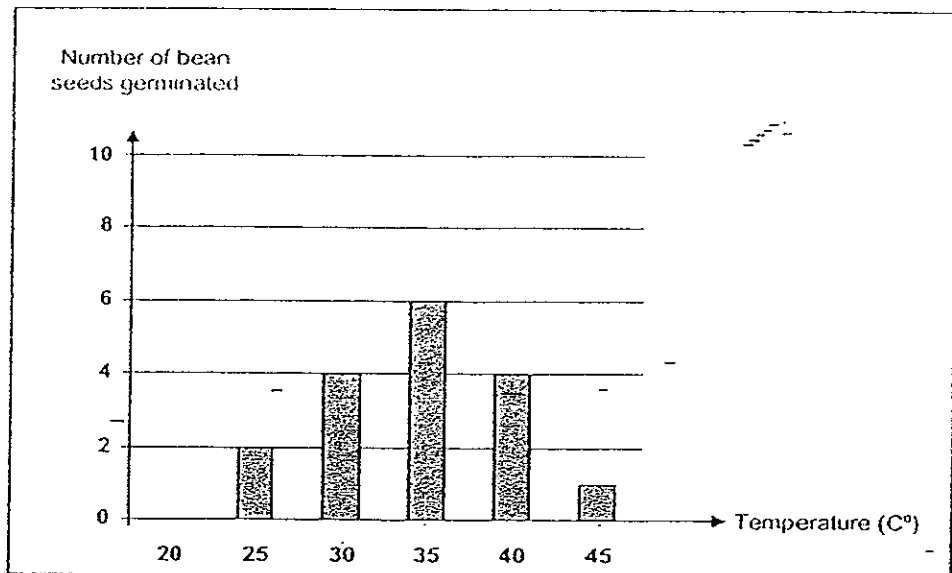

From the graph, which of the following statement could he conclude?

- (1) Bean seeds could germinate at any temperature above 0°C.
- (2) Bean seeds could not germinate at temperatures above 30°C.
- (3) The best temperature for the bean seeds to germinate was 35°C.
- (4) The number of bean seeds germinated increased as temperature increased.

16. Study the classification table below.

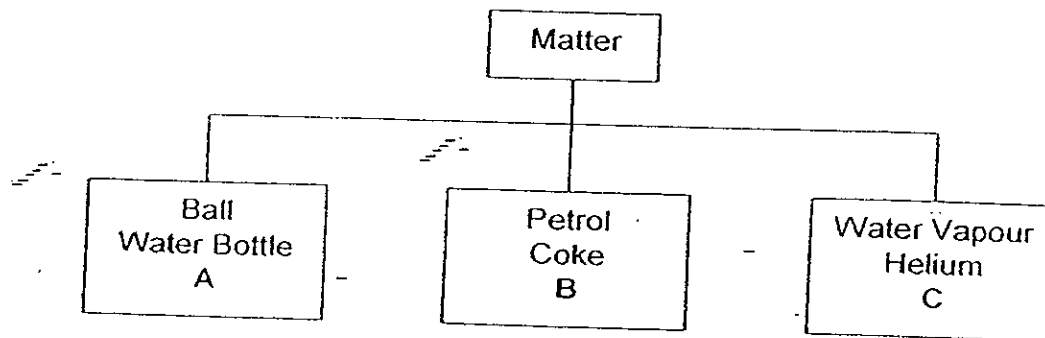

Which of the following objects are classified correctly?

	A	B	C
(1)	Metal	Honey	Dew
(2)	Wood	Oil	Cloud
(3)	Sponge	Diesel	Steam
(4)	Plasticine	Sponge	Nitrogen

17. Nicholas wanted to find out if there is air in the beaker of sand. Which of the following should he carry out to find a conclusion?

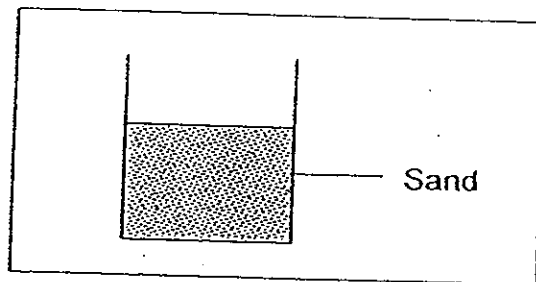

- (1) Heat the beaker of sand
- (2) Press on the beaker of sand
- (3) Pour some water into the beaker
- (4) Use a straw and blow into the sand

18. Diagram A shows a lump of plasticine in a jar containing some water. The plasticine is then cut into two pieces and put back into the same jar again as shown in Diagram B.

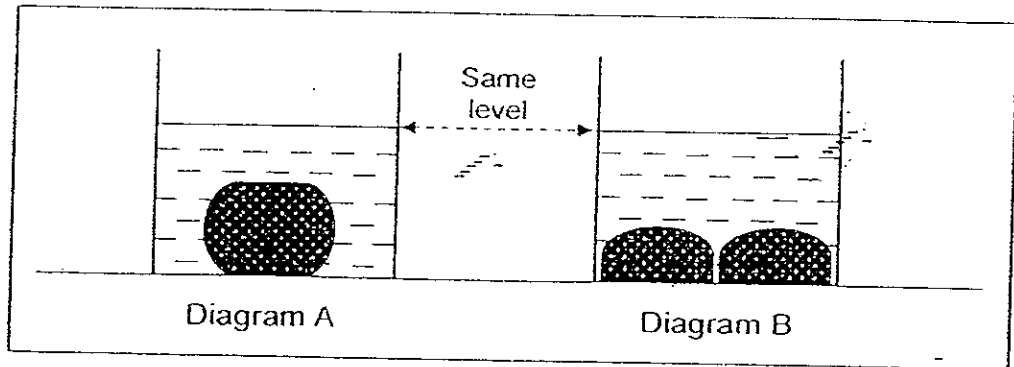

- What does the above-experiment show?

- (1) The plasticine has mass. ~~solid~~
  - (2) The plasticine is a soft ~~solid~~.
  - (3) The plasticine has a definite shape.
  - (4) The plasticine has a definite volume.
19. A pump is attached to a 100 cm<sup>3</sup> flask containing 60 cm<sup>3</sup> of water as shown. With each stroke of the pump, 10 cm<sup>3</sup> of air enters the flask.

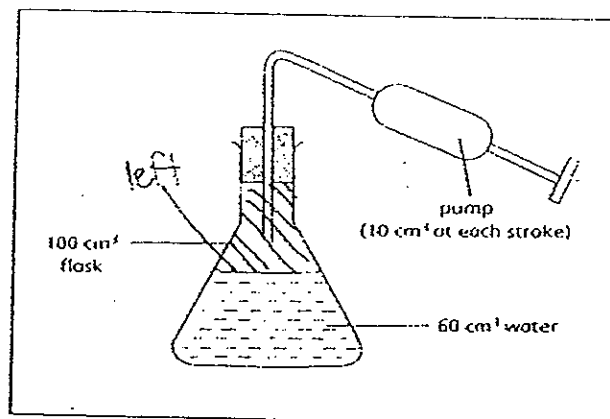





Nurul pumped 3 strokes of air into the flask. What is the volume of air in the flask now?

- (1) 10 cm<sup>3</sup>
- (2) 30 cm<sup>3</sup>
- (3) 40 cm<sup>3</sup>
- (4) 100 cm<sup>3</sup>

20. The diagram below shows a shadow formed.



Which one of the following objects could not have formed the shadow shown above?

<p>(1)</p>  <p>A metal ring</p>	<p>(2)</p>  <p>A vase</p>
<p>(3)</p>  <p>A cone</p>	<p>(4)</p>  <p>A container</p>

21. The diagram below shows the shadow of a pole cast at different times of the day.

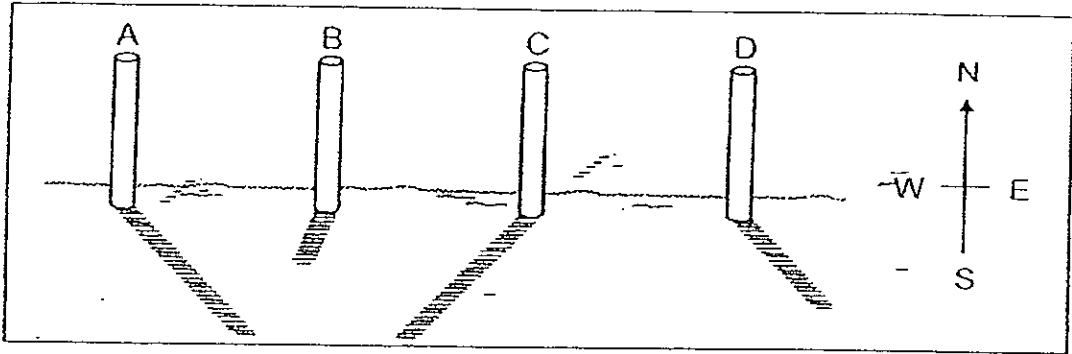

Arrange them in order of time, starting with the earliest time of the day.

Earliest

Latest

(1)	A	B	D	C
(2)	A	D	B	C
(3)	C	B	D	A
(4)	C	B	A	D

22. The diagram below shows a connection of pipes. 3 mirrors are placed inside the pipes. A, B, C and D represent the positions of the eye or the object.

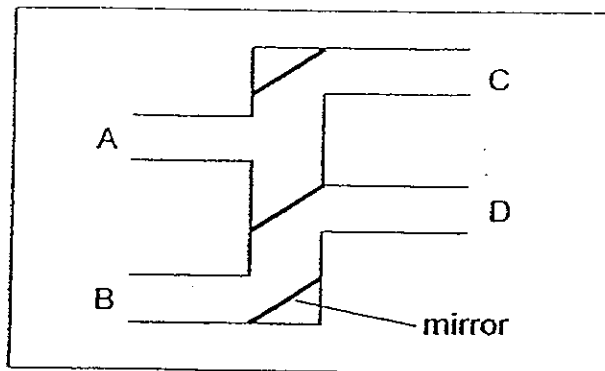

In order to see an object through the pipes, where should the eye and the object be placed respectively?

	Position of eye	Position of object
(1)	A	C
(2)	B	D
(3)	C	B
(4)	D	A

23. Maya wanted to conduct an experiment to find out whether shiny or dull surface reflect light better. In order to conduct a fair experiment, which of the following objects must Maya use?

- A: A torch
- B: A mirror
- C: A basin of water
- D: A piece of shiny blue foil
- E: A sheet of dull blue cardboard

- (1) A, B and C only
- (2) A, D and E only
- (3) A, B, D and E only
- (4) All of the above

24. Mr Tan carried out an experiment using four different materials of equal lengths. He placed one corner of each material into some coloured water. The diagram below shows what is observed at the end of the experiment.

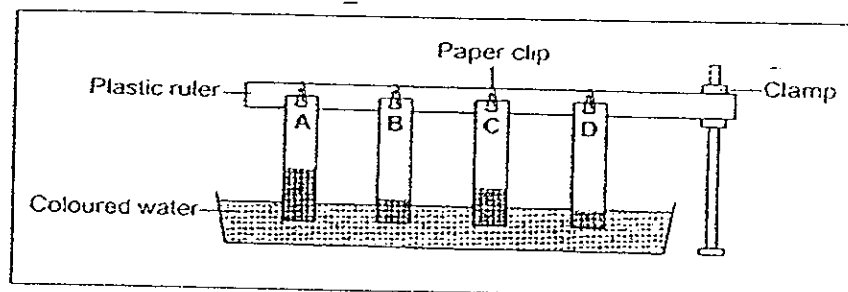

Which one of the following correctly represents the materials A, B, C and D?

	A	B	C	D
(1)	Cloth	Cardboard	Tissue paper	Aluminium foil
(2)	Tissue paper	Aluminium foil	Cloth	Cardboard
(3)	Aluminium foil	Cloth	Cardboard	Tissue paper
(4)	Tissue paper	Cardboard	Cloth	Aluminium foil

25. The classification table below shows two groups of objects.

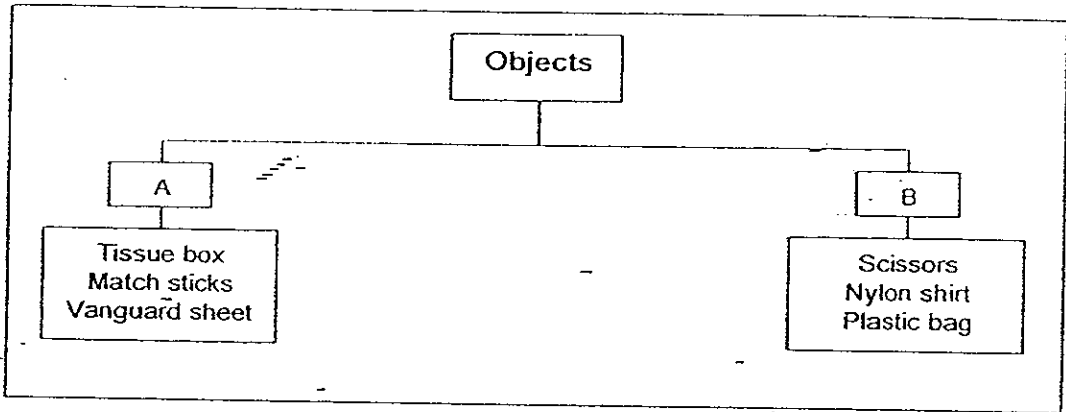

Which one of the following is the most suitable heading for 'A' and 'B'?

	A	B
(1)	Things that are soft.	Things that are hard.
(2)	Things made of wood.	Things made from plastic.
(3)	Things that are stretchable.	Things that are not stretchable.
(4)	Things that are once alive.	Things that are never alive.

26. The diagram below shows the positions of four different objects after they have been dropped into a trough of water.

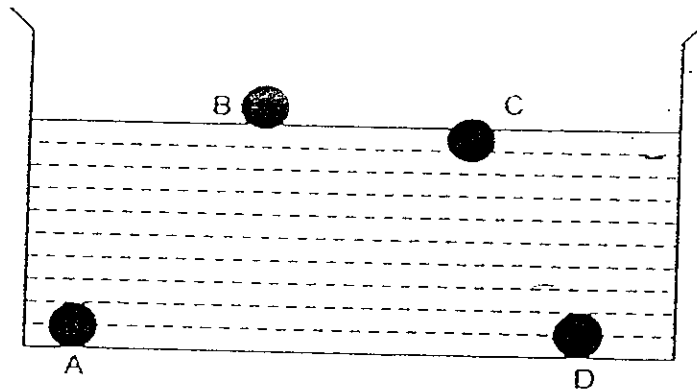

Which of the following correctly matches the objects above?

	A	B	C	D
(1)	Marble	Ping pong ball	Ice cube	Ten cent coin
(2)	Ice Cube	Ping pong ball	Ten cent coin	Marble
(3)	Ten cent coin	Ice cube	Ping pong ball	Marble
(4)	Marble	Ice cube	Ten cent coin	Ping pong ball



27. A light sensor in a data logger measures the amount of light that it is exposed to. Which of the following graphs shows how the reading of the data logger changes as the light source is moving away from the light sensor?

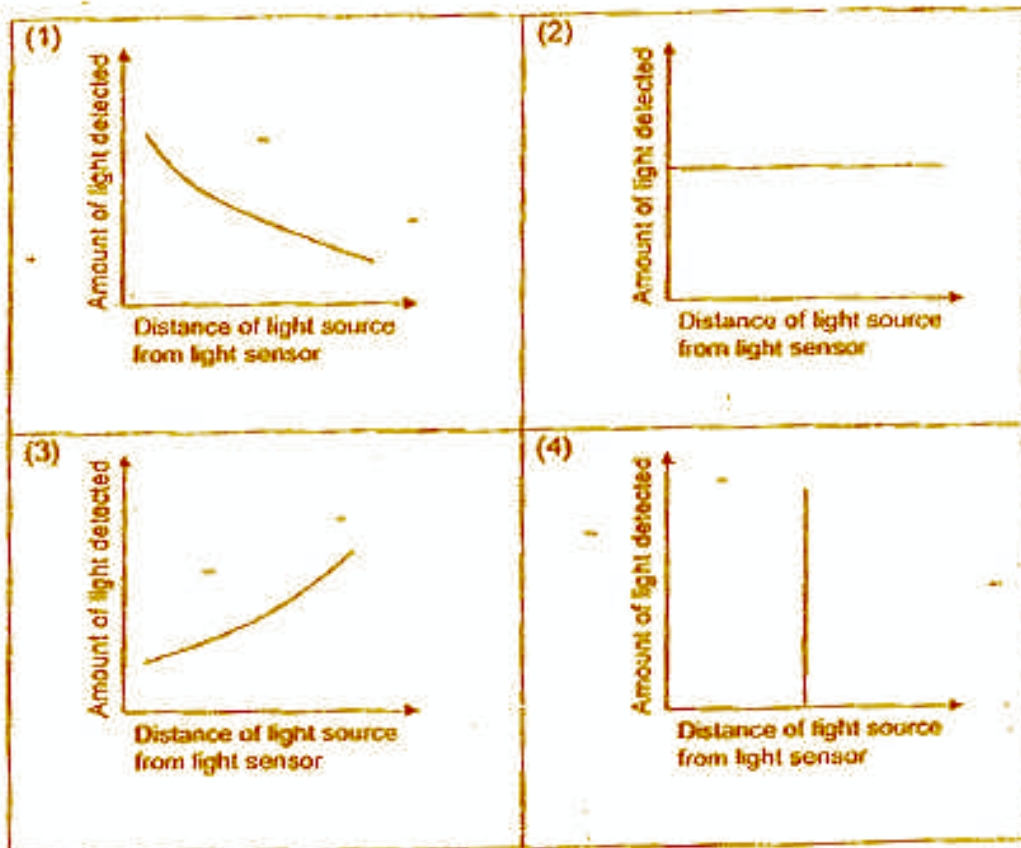

28. The diagram below shows 3 rings, A, B and C slotted through a metal rod. The rings are made of different materials and rings B and C were suspended freely.

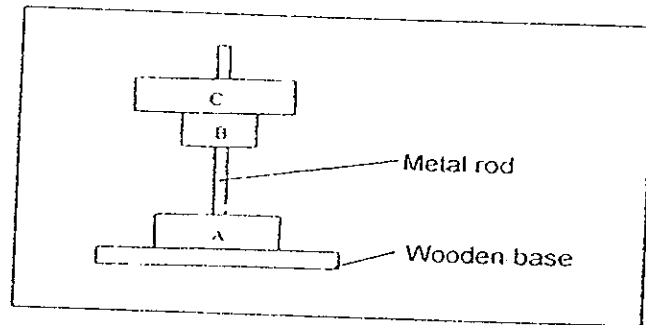

Based on the diagram above, which of the following statements are definitely true?

- A: Object A is a magnet.
- B: Object B is a magnet.
- C: Object C is a magnet.
- D: Object B is made of iron.
- E: Object C is made of magnetic material.

- (1) A and B only
- (2) A, B and D only
- (3) A, B, D and E only
- (4) All of the above

29. When 4 metallic objects were hung on a wooden rod, the following observation was made.

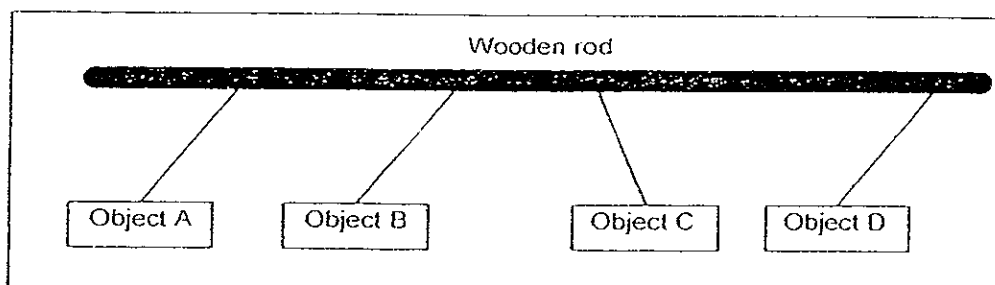

Which of the following best describes the objects?

	Object A	Object B	Object C	Object D
(1)	Magnet	Magnet	Magnet	Magnetic material
(2)	Magnet	Magnet	Magnetic material	Magnet
(3)	Magnetic material	Magnetic material	Magnet	Magnetic material
(4)	Magnetic material	Magnetic material	Magnetic material	Magnet

30. The set-up below shows 3 similar magnets and a compass.

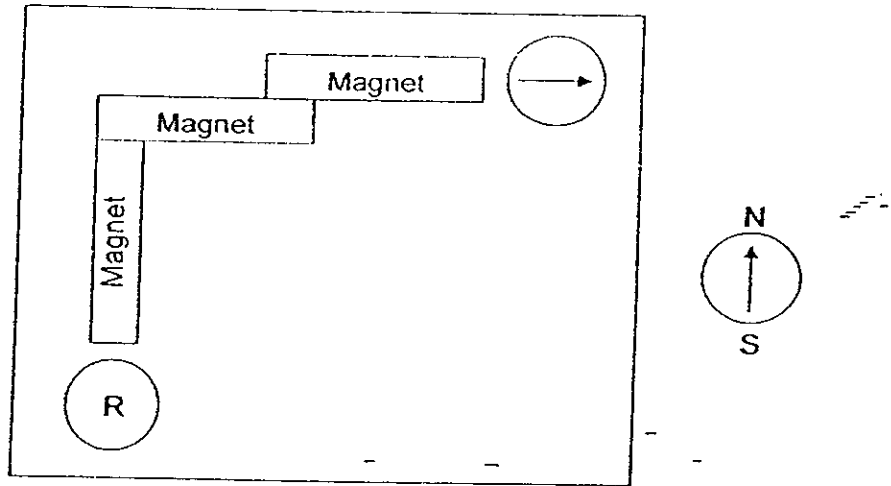

Which one of the following compasses correctly represents the compass R in the above set-up?

(1)	(2)
(3)	(4)

METHODIST GIRLS' SCHOOL (PRIMARY)

PRIMARY 4

FIRST SEMESTRAL ASSESSMENT 2008

SCIENCE

BOOKLET B1

SECTION	MARKS
A	60
B1	20
B2	20
TOTAL	100

NAME: \_\_\_\_\_ (      )

CLASS: \_\_\_\_\_

Total time for Booklets A and B: 1 h 30 min.

DO NOT OPEN THIS BOOKLET UNTIL YOU ARE TOLD TO DO SO.  
FOLLOW ALL INSTRUCTIONS CAREFULLY.

Section B : ( 40 marks )

Write the answers in the blanks provided.

31. Study the classification chart below.

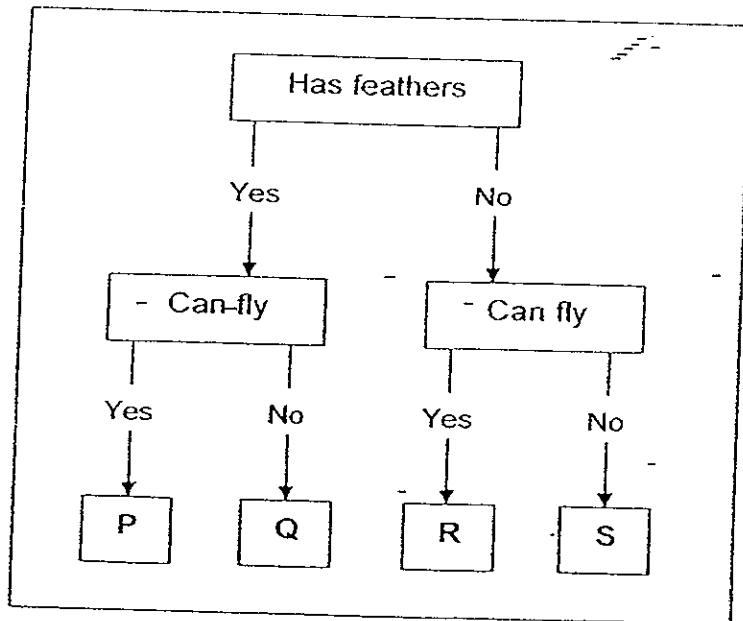

Based on the classification chart above, indicate whether each of the following statements is True or False.

Put a tick ( ✓ ) in the correct box below.

(2m)

	Statement	True	False
(a)	P is an insect.		
(b)	S is not a bird.		
(c)	R is a mosquito.		

(d) Give an example of an animal that Q could possibly be.

(1m)

\_\_\_\_\_

32. Sophia studied the living things shown in the list below.

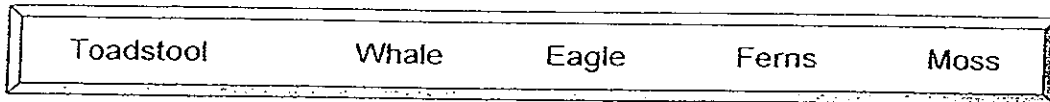

She then classified some of the living things in a group as shown here.

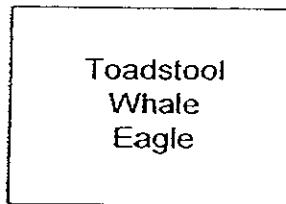

(a) Which characteristic of living things did Sophia use to classify the above? (1m)

The living things above \_\_\_\_\_  
\_\_\_\_\_

She then realized that the living things could be grouped in another way.

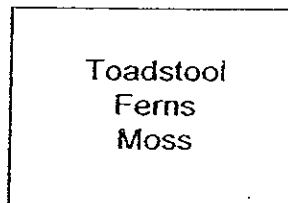

(b) Which characteristics of living things did she use to classify the above? (1m)

The living things above \_\_\_\_\_  
\_\_\_\_\_

33. Rachel read the following article about the life cycle of an animal from the Internet.

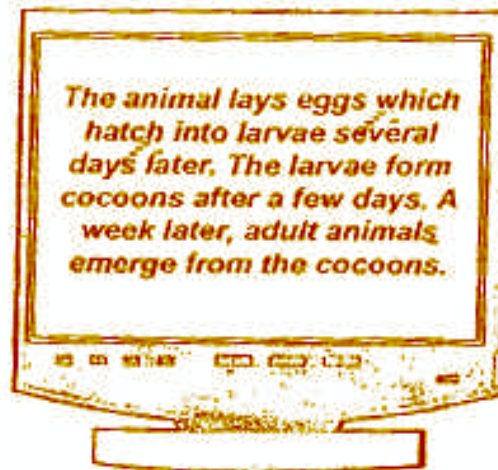

Based on the article above, complete the life cycle of the animal in the box provided below. (2m)

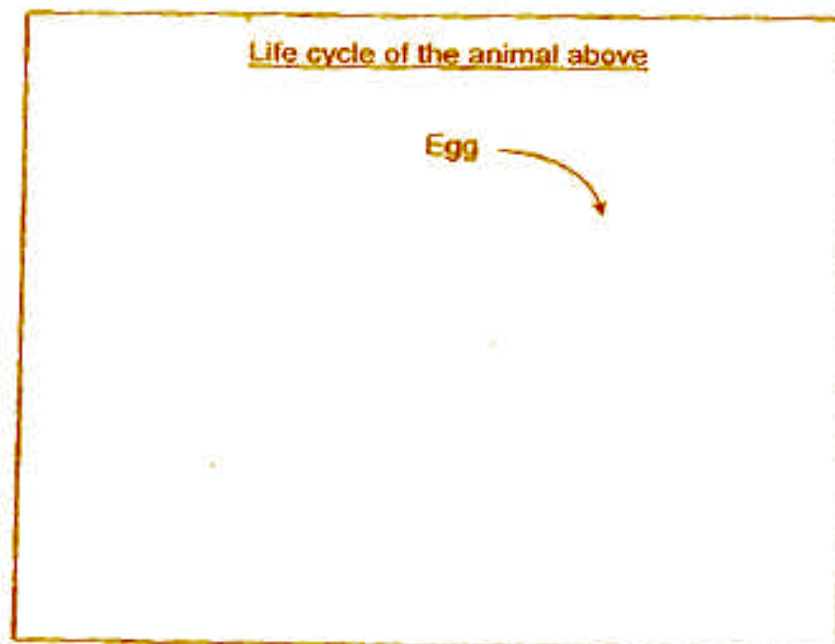



34. Sarah wanted to carry out an experiment as shown. Using an inverted jar, she trapped 10 ants in the centre of a circular tray. She then placed a spoonful of sugar of different colours at four positions near the edges of the tray as shown in the diagram below.

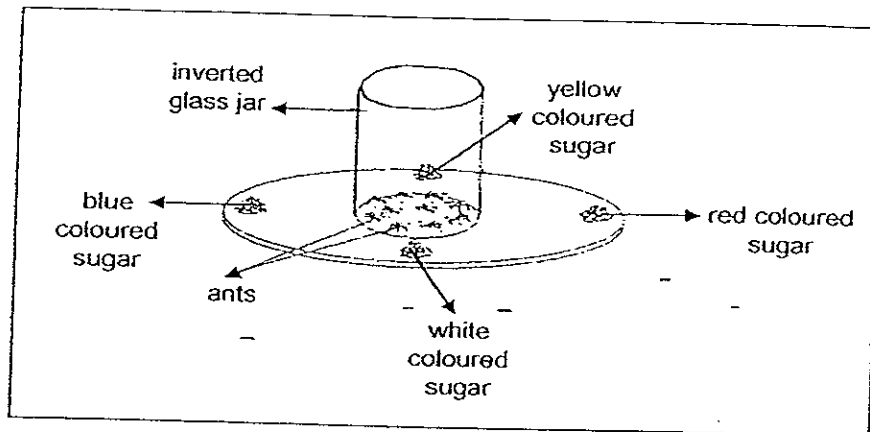

Sarah lifted the glass jar and observed where most of the ants moved to.

Sarah's friends, Amy, Betty and Clara tried to guess the aim of her experiment. They each made the following statements:

- Amy : Sarah wanted to find out if ants were attracted to sugar.  
 Betty : Sarah wanted to find out the type of food ants preferred.  
 Clara : Sarah wanted to find out the colour of sugar ants preferred.

- (a) Who made the correct statement? (1m)

- (b) In the table below, state one variable that must be kept the same and one variable that must be different so that the experiment is a fair one. (2m)

Variable that must be kept the same	Variable that must be different

35. Sandra carried out an experiment on a seed growing into a seedling as shown below.

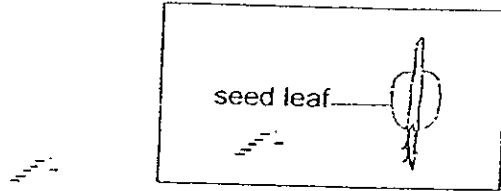

The curves in the graphs below show changes in the mass of the seed leaf over time.

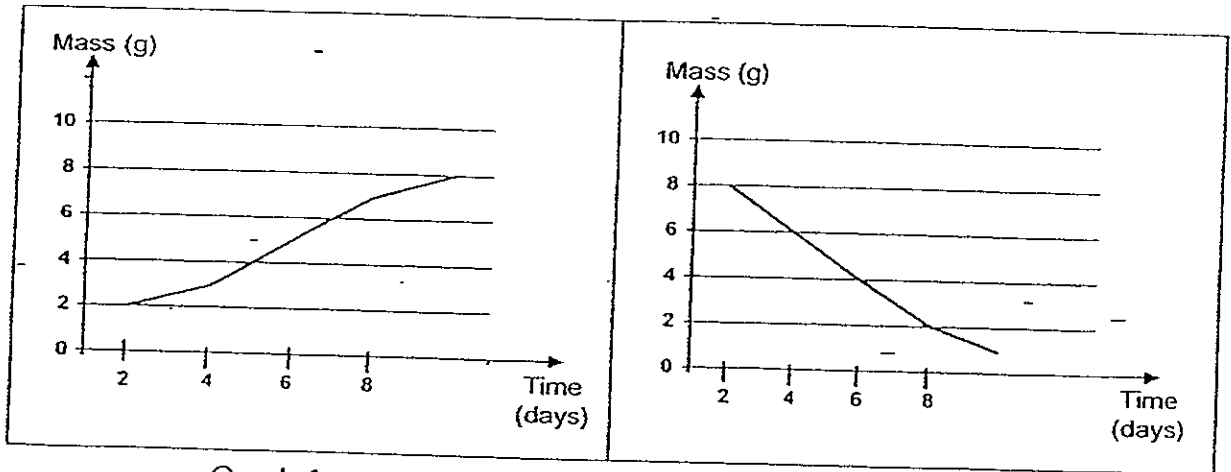

Graph A

Graph B

- (a) Which graph, A or B, correctly shows how the mass of the seed leaf will change over time? (1m)

\_\_\_\_\_





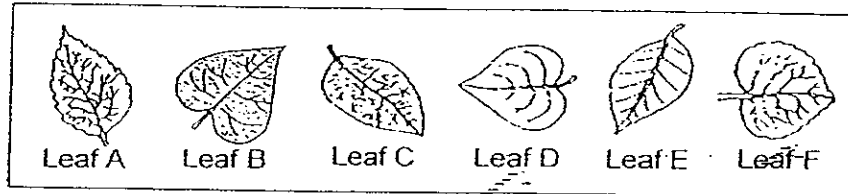

- (b) How did the seedling get its food after day 8? (1m)

\_\_\_\_\_  
\_\_\_\_\_

36. Gloria and Nancy were told to group the leaves below based on the similarities they shared.



Gloria grouped the leaves as shown below.

Group 1	Group 2
 Leaf A   Leaf F	 Leaf B   Leaf C  Leaf D  Leaf E





- (a) What would be the headings for Group 1 and Group 2 in Gloria's grouping? (1m)

Group 1 : \_\_\_\_\_

Group 2 : \_\_\_\_\_

(Question 36 continues on next page)

Nancy, however, grouped the leaves as shown below.

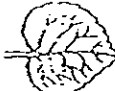
Group 3	Group 4
 <p data-bbox="643 667 735 696">Leaf A</p>  <p data-bbox="520 831 608 860">Leaf E</p>  <p data-bbox="743 831 831 860">Leaf C</p>	 <p data-bbox="1038 663 1134 692">Leaf B</p>  <p data-bbox="975 837 1062 866">Leaf D</p>  <p data-bbox="1126 837 1214 866">Leaf F</p>

- (b) What would be the headings for Group 3 and Group 4 in Nancy's grouping? (1m)

Group <sup>3</sup> X : \_\_\_\_\_

Group <sup>4</sup> X : \_\_\_\_\_

37. The diagram below shows different parts of a coconut tree labelled, A, B, C and D.

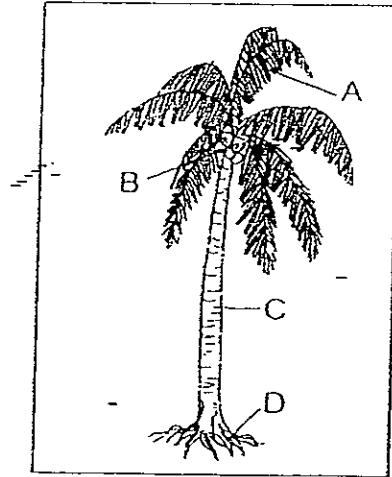

- (a) Which of the part labelled above transports water and food to other parts of the tree? (½m)
- 
- (b) What is the function of part A? (1m)
- 
- 
- (c) What will happen to the tree if part D is completely removed? Give a reason for your answer. (1½m)
- 
-

38. The diagram below shows a working model of a human chest. A rubber sheet is stretched across the bottom of the bell jar and tied firmly in place.

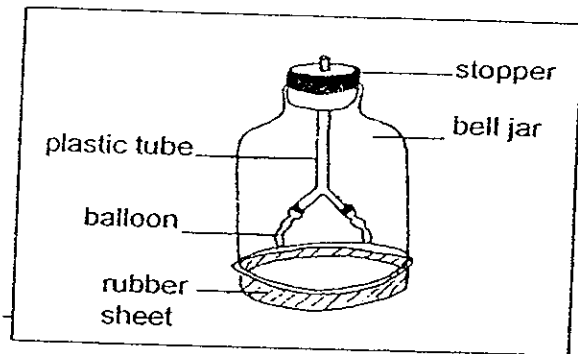

- (a) Which parts of the organs in our respiratory system do the following parts of the model represent? (2m)

Model	Organs
plastic tube	-
- balloon	-
rubber sheet	-

- (b) What will happen to the balloons in the bell jar when the rubber sheet is pulled down? (1m)

---



---

METHODIST GIRLS' SCHOOL (PRIMARY)

PRIMARY 4

FIRST SEMESTRAL ASSESSMENT 2008

SCIENCE

BOOKLET B2

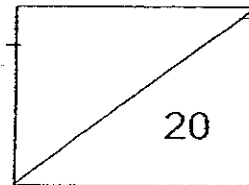

NAME : \_\_\_\_\_ (       )

CLASS : \_\_\_\_\_

Total time for Booklets A and B: 1 h 30 min.

**DO NOT OPEN THIS BOOKLET UNTIL YOU ARE TOLD TO DO SO.  
FOLLOW ALL INSTRUCTIONS CAREFULLY.**

Section B : ( 40 marks )

Write the answers in the blanks provided.

39. Study the classification chart below carefully and answer the following questions.

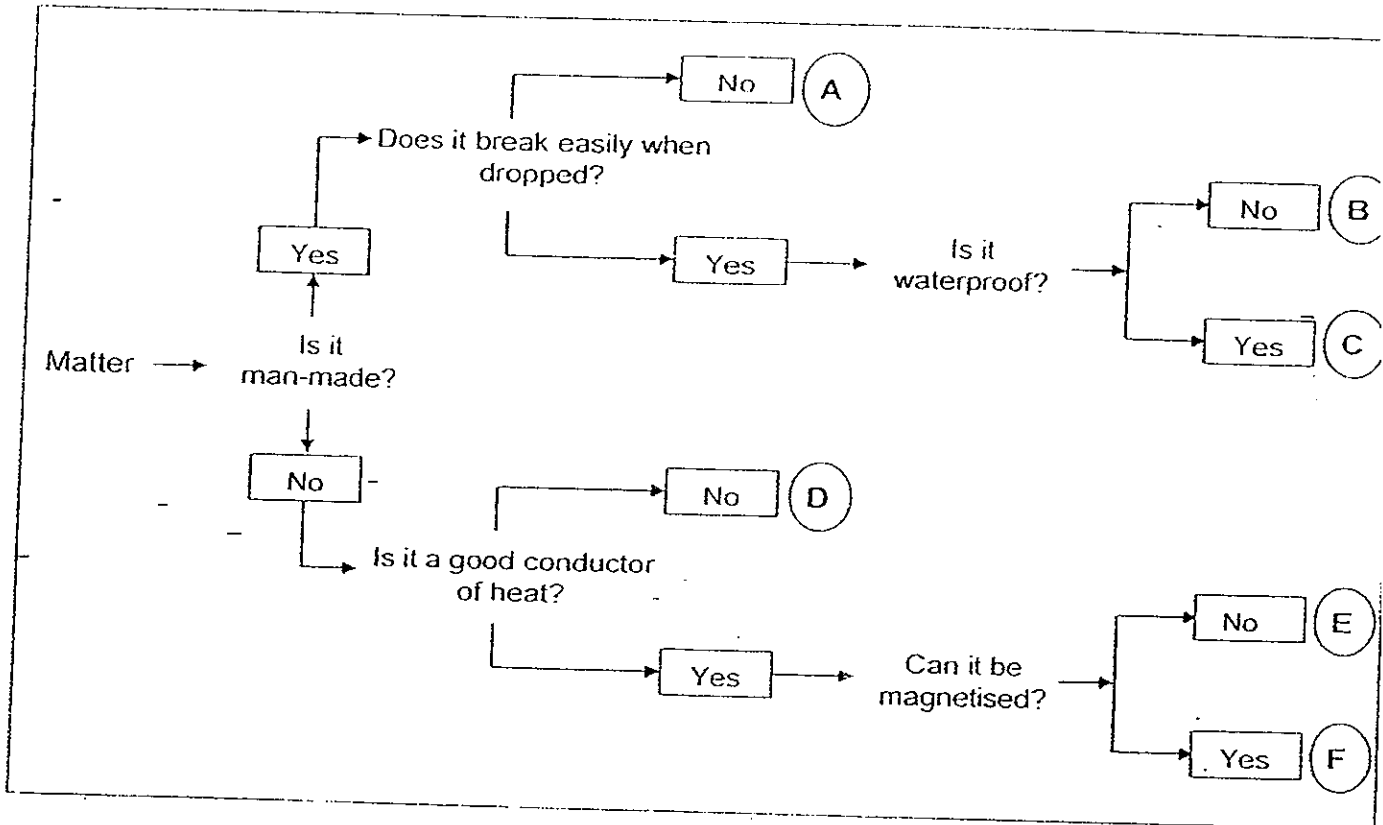

- (a) Based on the chart above, what are the characteristics of object B? (1m)

---

---

- (b) What could object E be? (1m)

---



40. The communicating vessel shown below is filled with water. The water level in A is shown.

(a) Draw the water level in B, C and D in the diagram. (1m)

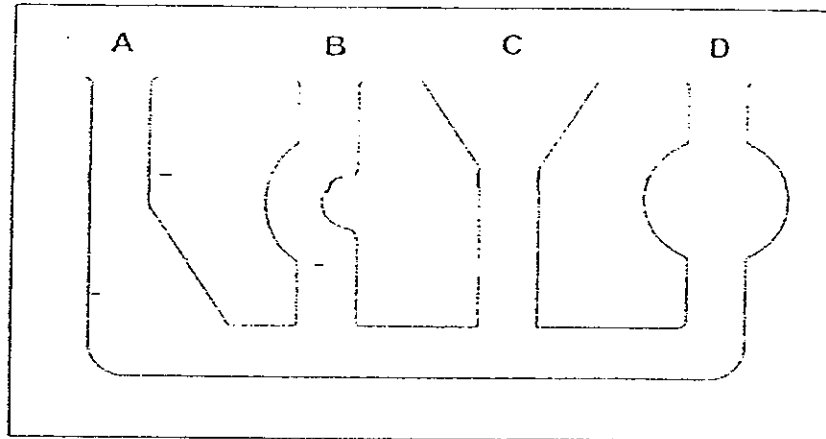

(b) Diagram A below shows the number of weights, W, needed to balance a can of fruits, F. Diagram B shows that 2 cans of fruits balance one bag of sugar, S.

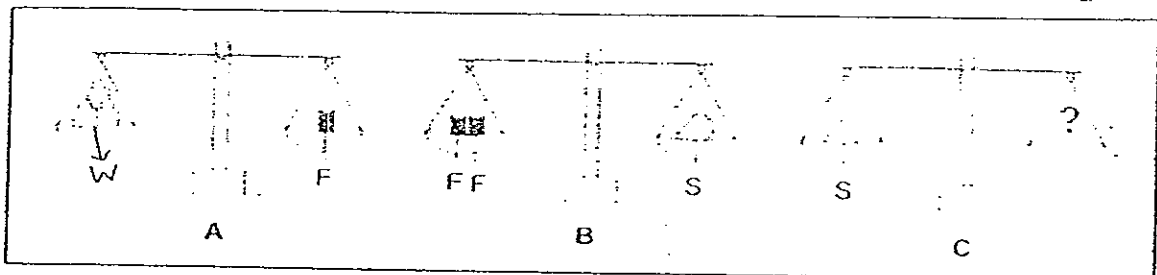

(i) How many weights are needed to balance the bag of sugar in diagram C? (1m)

---

(ii) Which one of the items above is the heaviest? (1m)

---

41. The following experiment was carried out in a dark room. Four Sheets A, B, C and D of different materials were arranged in a straight line as shown below. When the torch was switched on, a bright circular patch of light was seen on sheet C only.

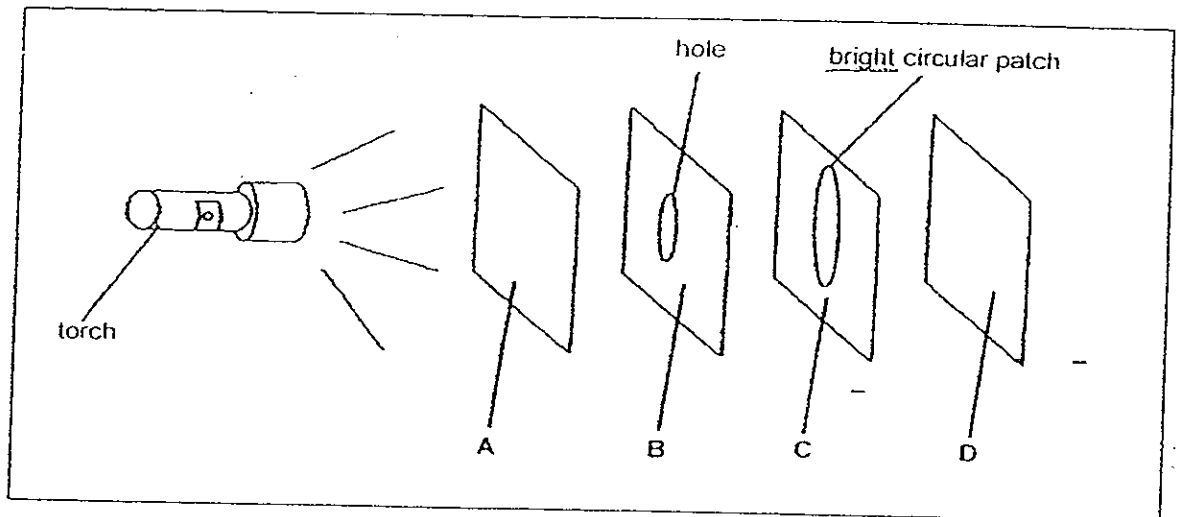

- (a) State whether the following sheets are 'transparent', 'translucent' or 'opaque'. (1m)

A: \_\_\_\_\_

B: \_\_\_\_\_

- (b) Give an example of the material for Sheet C. (1m)

\_\_\_\_\_

- (c) What property of light is demonstrated in the above experiment? (1m)

\_\_\_\_\_

\_\_\_\_\_

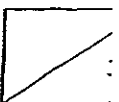

42. The diagram below shows a conical flask filled with oil.

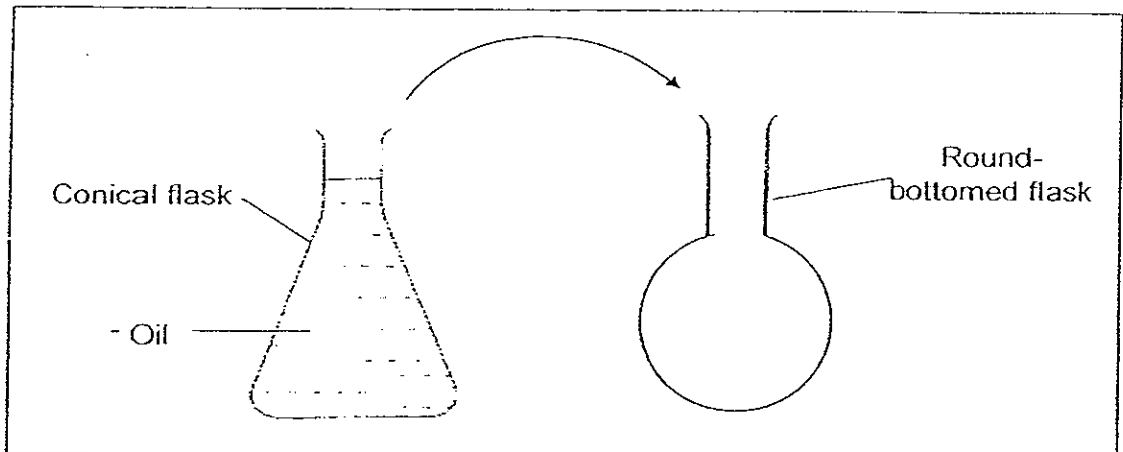

Tom wanted to transfer all the oil in the conical flask into the round-bottomed flask.

What will happen to the shape and volume of the oil when it is transferred to the round-bottomed flask? Why? (2m)

---

---

---

---

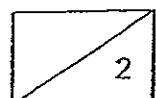

43. Mr Raja had 3 balls as shown below. He found out that the 3 balls have different masses.

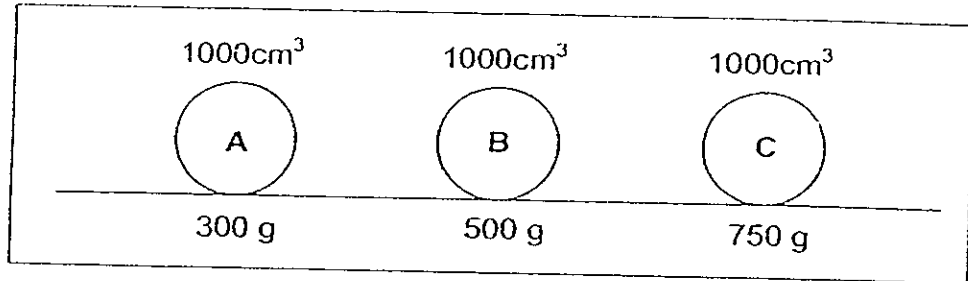

- (a) Based on the above diagram, list one similarity between the 3 balls. (1m)
- \_\_\_\_\_
- \_\_\_\_\_
- (b) Explain why the mass of the 3 balls could be different. (1m)
- \_\_\_\_\_
- \_\_\_\_\_
- \_\_\_\_\_

44. Study the diagram below carefully.

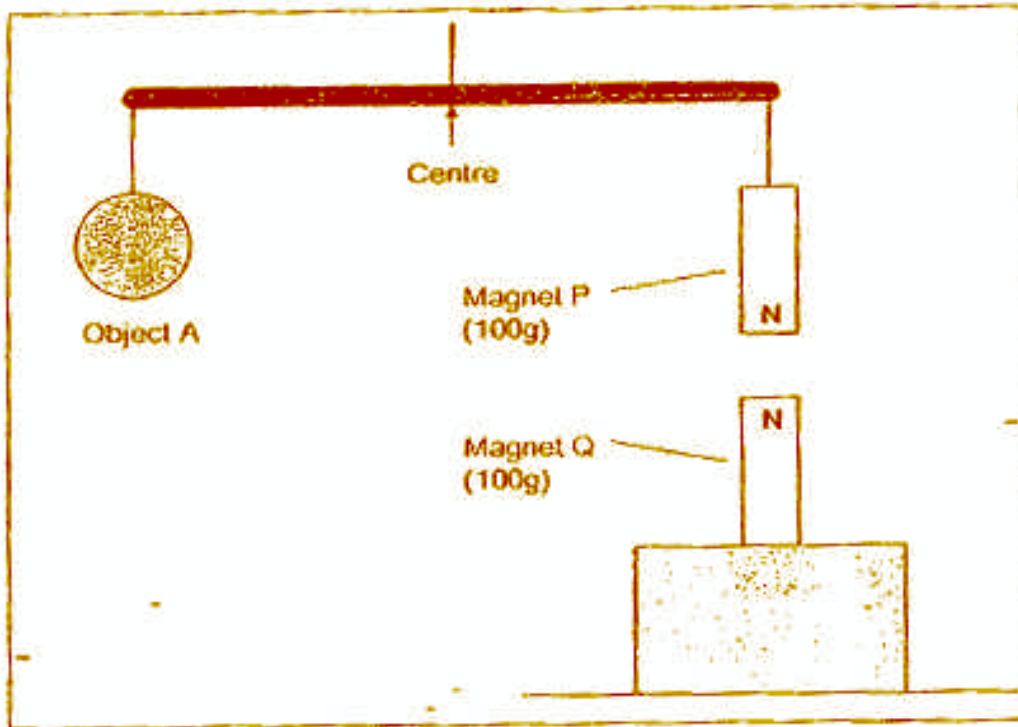

Object A and Magnet P are balanced equally as shown in the diagram above. Magnet Q is fixed to a box with its North-seeking facing the North-seeking pole of Magnet P.

- (a) Is Object A less than, equal to or greater than 100g? (1m)

---

---

- (b) Name a magnetic material you would use to replace magnet Q if you want magnet P to move downwards. Explain your answer. (1m)

---

---

45. The diagram below shows three circles of different sizes cut from various materials.

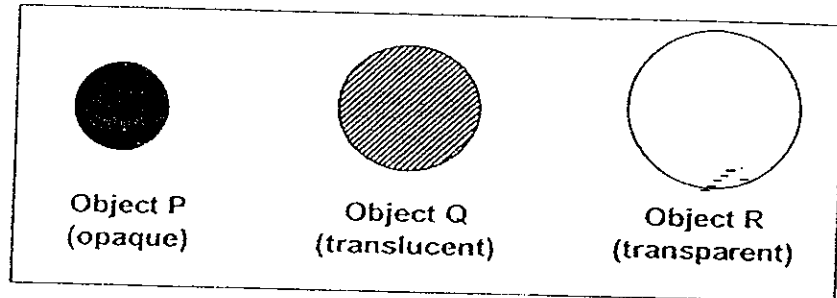

The objects are then suspended by strings and placed between a torchlight and a white screen.

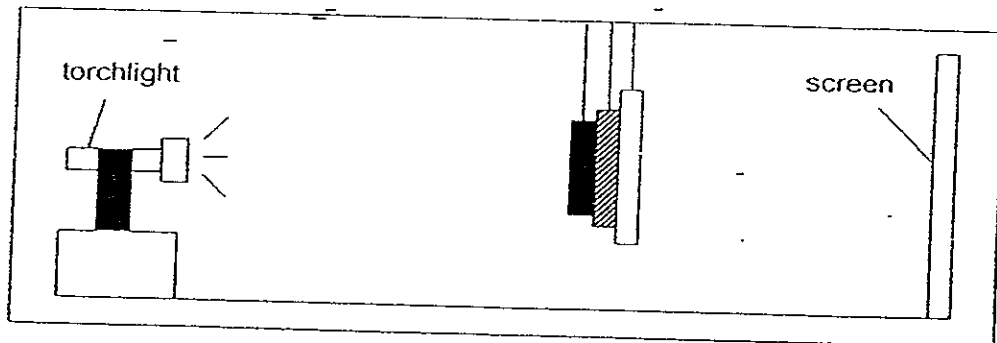

- (a) If object P were to be moved closer to the torchlight, put a tick (✓) in the table for part (i) to (iv) below to show if the images formed are possible or not. (2m)

	Image	Possible	Not Possible
(i)			
(ii)			

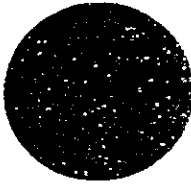
	Image	Possible	Not Possible
(iii)			
(iv)			

(1m)

(b) Name the material that object Q is likely to be.

(1m)

---

46. Ali mixed some coarse sand, iron filings and tiny pieces of styrofoam in a tank as shown below.

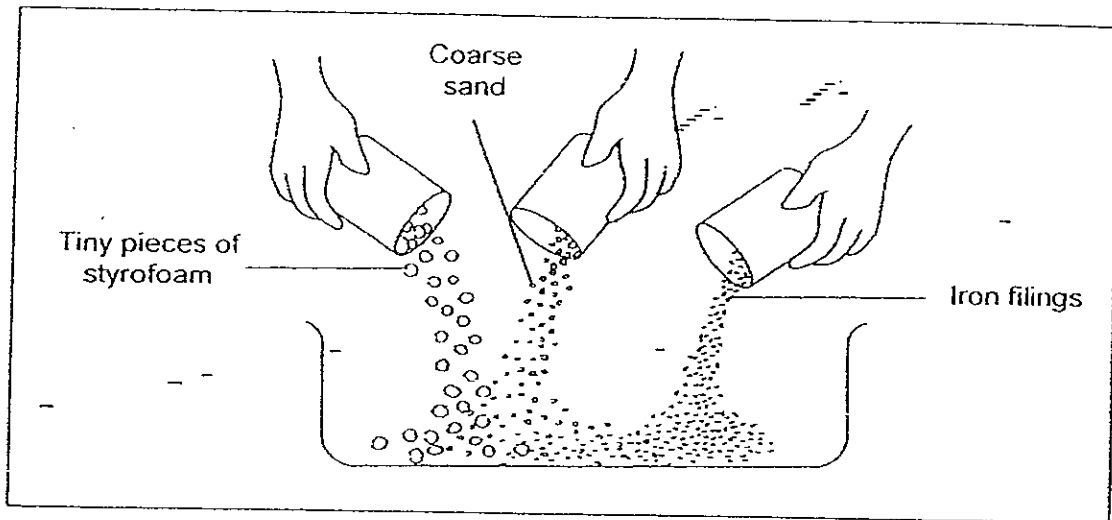

Explain what he can do to separate the three materials from each other. (3m)

Step 1	
Step 2	
Step 3	



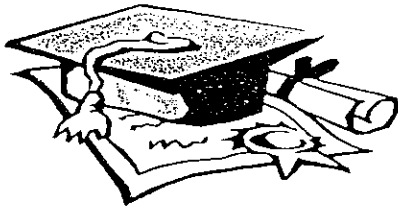

# ANSWER SHEET

EXAM PAPER 2008

SCHOOL : M G S PRIMARY SCHOOL

SUBJECT : PRIMARY 4 SCIENCE

TERM : SA 1

Q1	Q2	Q3	Q4	Q5	Q6	Q7	Q8	Q9	Q10	Q11	Q12	Q13	Q14	Q15	Q16	Q17
3	2	1	4	4	1	2	1	3	3	3	3	3	4	3	3	3

Q18	Q19	Q20	Q21	Q22	Q23	Q24	Q25	Q26	Q27	Q28	Q29	Q30
4	3	1	3	2	2	4	4	1	1	1	1	2

31) A) a) F b) T c) t

B) An emu

32) a) cannot make their own food

b) reproduce by spores.

33)

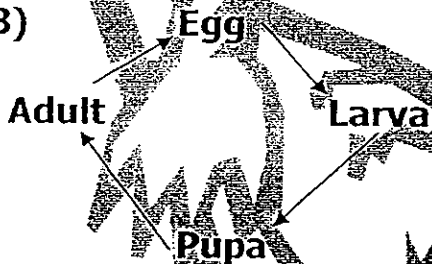

34) a) Clara

b) The distance between the sugar and the ants. / Different colours of the sugar.

35)a)Group B

b)It can make its own food with its leaves in the process of photosynthesis.

36)a)1:Toothed—edged leaves

2:Smooth—edged leaves

b)3:Oval—shaped leaves

4:Heart—shaped leaves

37)a)Part C

b)It is to make food for the tree through a process called photosynthesis.

c)The tree will die. Without roots, the tree cannot anchor itself firmly to the ground and absorb water and mineral salts from the soil.

38)a)i)Windpipe ii)Lungs iii)Diaphragm

b)The balloons will inflate.

39)a)It is man-made, breaks easily when dropped and is not waterproof.

b)Copper

40)a)

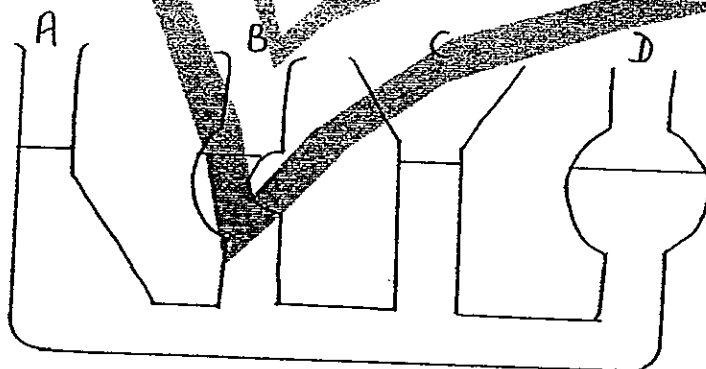

b)i)Six weights ii)Item S

41)a)A: Transparent B: Opaque

b)Paper

c)Light travels in a straight line.

42)The shape would change but the volume would stay the same. Liquids do not have a definite shape but they have a definite volume.

43)a)They all have the same volume.

b)The balls are made of different materials.

44)a)It is less than 100g.

b)Lodestones. It is a magnetic material and it is used to make magnets, so it can attract magnet P

45)a)i)Not ii)Not iii)Possible iv)Possible

b)Tracing paper.

46)1=Use a magnet to attract the iron fillings out of the tank

2=Pour water into the tank. The tiny pieces of Styrofoam would float scoop them up.

3=Lastly, pour the water out of the tank and you are left with the coarse sand. You have separated the materials a ready.

---end---