

# Anglo-Chinese School (Junior)



## SEMESTRAL ASSESSMENT 2 (2019)

PRIMARY 3

SCIENCE

BOOKLET A

Thursday

31 October 2019

1 h 45 min

Name: \_\_\_\_\_ ( ) Class: 3.( )

### INSTRUCTIONS TO PUPILS

- 1 Do not turn over the pages until you are told to do so.
- 2 Follow all instructions carefully.
- 3 There are 28 questions in this booklet.
- 4 Answer ALL questions.
- 5 Shade your answers in the Optical Answer Sheet (OAS) provided.

---

This question paper consists of 17 printed pages (inclusive of cover page).



**Booklet A**

For each question from 1 to 28, four options are given. One of them is the correct answer. Make your choice (1, 2, 3 or 4). Shade your answer on the Optical Answer Sheet.

(56 marks)

1. Study the classification chart.

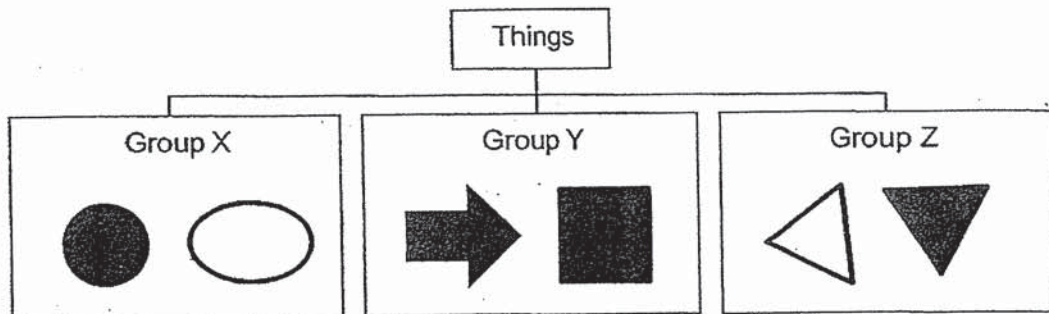

Which of the following can be best classified in Group Y?

(1)



(2)



(3)



(4)



2. Jane set up an experiment as shown in the diagram.

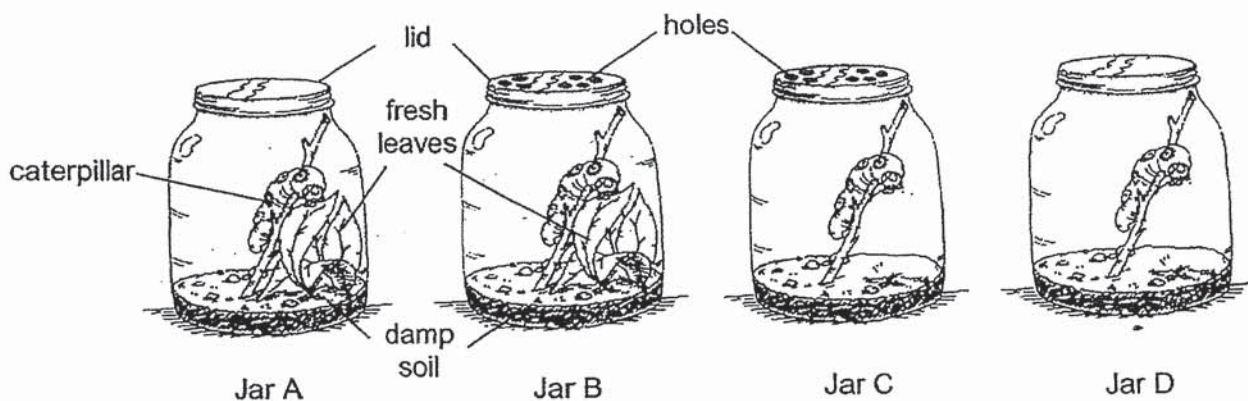

In which of the jar will the caterpillar stay alive for the longest period of time?

- (1) A  
 (2) B  
 (3) C  
 (4) D

3. Study the classification table.

Living Things	Non-Living Things
Butterfly	Light
Cactus	Fan
Robot	Shadow
Fern	Apple juice

Which of the following things is **incorrectly** classified?

- (1) Fan-
- (2) Fern
- (3) Robot
- (4) Butterfly

4. Study the pictures.

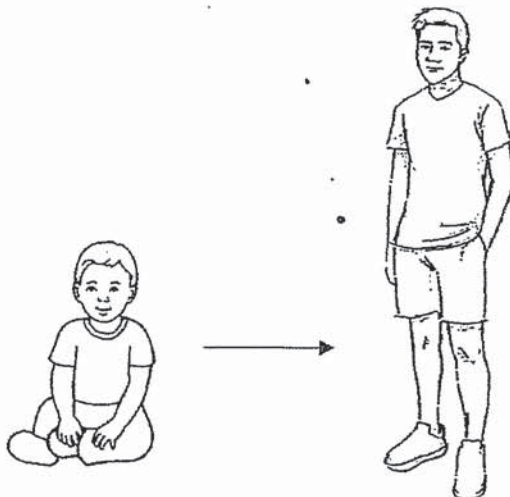

Which of the following characteristics of living things is observed?

- (1) Living things grow.
- (2) Living things reproduce.
- (3) Living things respond to changes.
- (4) Living things need air, food and water to survive.

5. Study Plants A and B.

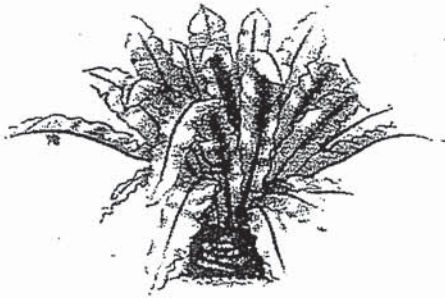

Plant A



Plant B

Which of the following statements is **incorrect** about Plants A and B?

- (1) Both plants need air, food and water to survive.
- (2) Both plants have flowers, leaves, stems and roots.
- (3) Plant A is a non-flowering plant while Plant B is a flowering plant.
- (4) Plant A reproduces by spores while Plant B reproduces by seeds.

6. Leela wants to carry out an experiment to find out if the growth of a plant is affected by the amount of light it receives. She prepared four set-ups.

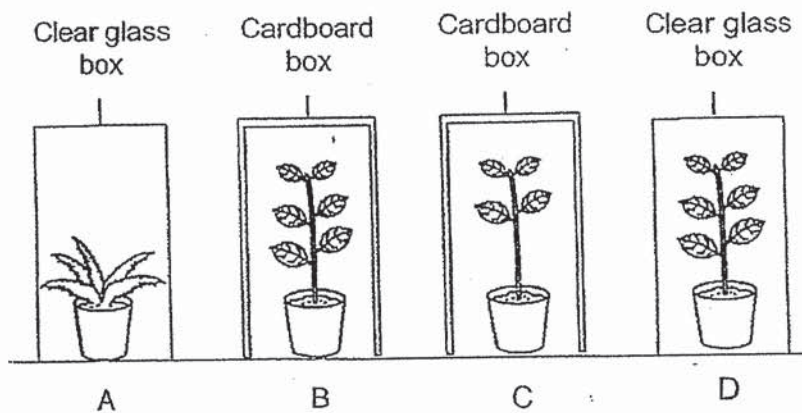

Which two set-ups should Leela place in an open field to test her aim?

- (1) A and B
- (2) B and C
- (3) B and D
- (4) C and D

7. Study the classification chart.

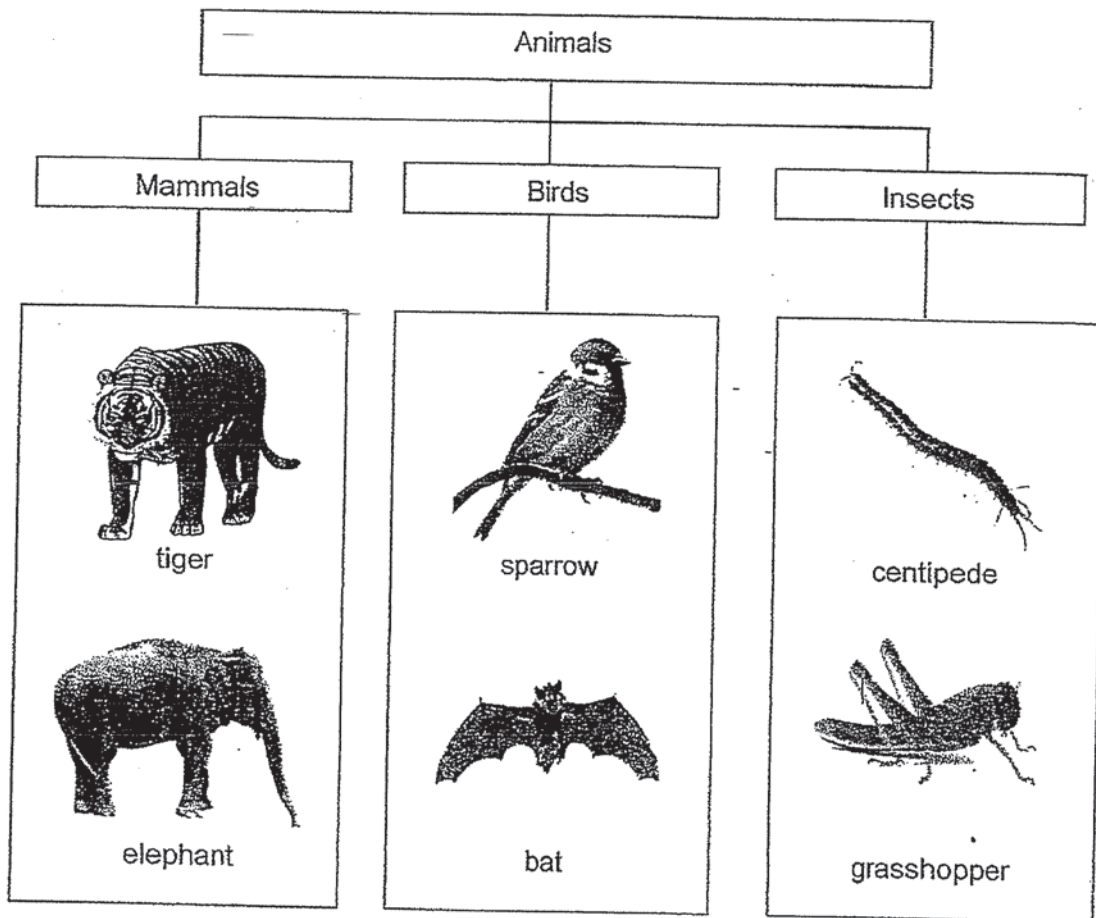







Which of the following two animals are placed in the **incorrect** group?

- (1) tiger and bat
- (2) bat and centipede
- (3) centipede and sparrow
- (4) elephant and grasshopper



8. Study the table.

Group 1	Group 2	Group 3
 Chicken	 Dolphin	 Salamander
 Eagle	 Goldfish	 Horse

Which of the following correctly describes how the animals are being grouped?

- (1) Outer covering
  - (2) Number of legs
  - (3) Where they live
  - (4) How they reproduce
9. Devi found Animal X in the garden. Which of the following statements will confirm that it is an insect?
- (1) It has wings.
  - (2) It has eight legs.
  - (3) It has three body parts.
  - (4) It has an outer covering of hair.

10. Study the pictures of the platypus and duck.

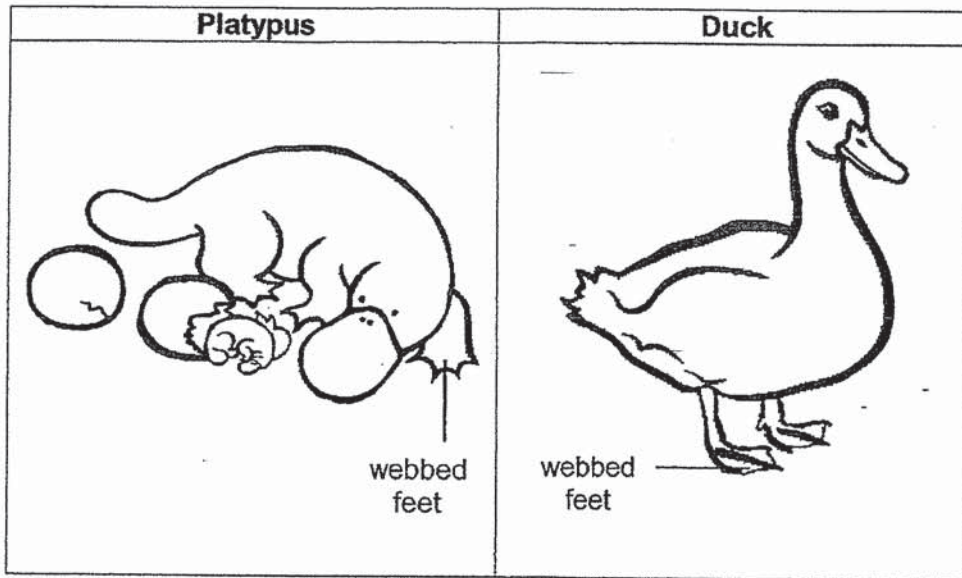

Which of the following characteristics confirms that the duck is a bird, unlike the platypus?

- (1) It has a tail.
  - (2) It lays eggs.
  - (3) It has webbed feet.
  - (4) It has an outer covering of feathers.
11. The table shows the different characteristics of living things, X, Y and Z. A tick(✓) shows that the living thing has that characteristic.

Characteristic	X	Y	Z
Able to make food		✓	
Reproduce by spores		✓	
Can be used to make bread	✓		
Can only be seen with a microscope	✓		✓

Based on the information in the table, which of the following correctly represents X, Y and Z?

	X	Y	Z
(1)	bacteria	mould	yeast
(2)	yeast	fern	bacteria
(3)	bacteria	fern	mould
(4)	yeast	mould	bacteria



12. Bala carried out an experiment with four different types of hand sanitizer that kills bacteria. He put the same amount of bacteria on each plate. He then put the same amount of hand sanitizer on each plate and recorded the amount of bacteria left on the plate after 10 minutes as shown.

Plate with Hand Sanitizer	Amount of bacteria left (unit)
W	10
X	45
Y	32
Z	8

Which hand sanitizer is the most effective in killing bacteria?

- (1) W  
 (2) X  
 (3) Y  
 (4) Z
13. Mrs Tan accidentally left a tomato in the kitchen. Two days later, she noticed Organism F growing on it.

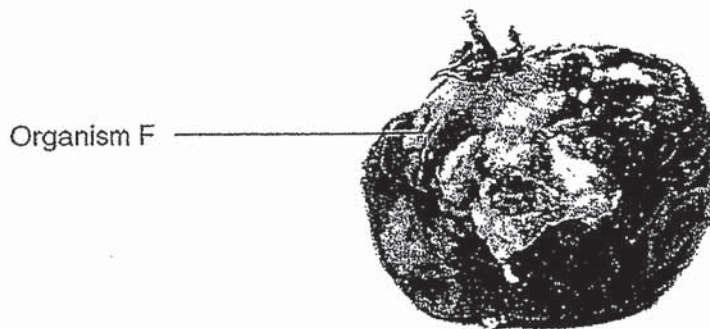

Mrs Tan made the following conclusions about Organism F.

- A It is edible.  
 B It needs sunlight to grow.  
 C It gets its nutrients from the tomato.

Which of the following conclusions is/are correct?

- (1) C only  
 (2) A and B only  
 (3) B and C only  
 (4) A, B and C

14. Jason placed his damp towel into the laundry basket after drying himself with it. A few days later, he found mould growing on his towel.

What should Jason have done to avoid mould growing on his towel?

- (1) Place the laundry basket in a dark room.
- (2) Dry the towel before putting it into the laundry basket.
- (3) Fold the towel before putting it into the laundry basket.
- (4) Sprinkle some water onto the towel before putting it into the laundry basket.

15. Suzy, Michael and Rosie described the properties of item Z.



Suzy

It is strong.  
It does not absorb water.

It allows light to pass through.  
It is flexible.



Michael



Rosie

It sinks in water.  
It does not break easily.

Their teacher said that only Michael's statements are incorrect.

Which of the following best represents item Z?

- (1) Metal pen
- (2) Plastic bag
- (3) Rubber band
- (4) Glass cylinder

16. Study the flowchart.

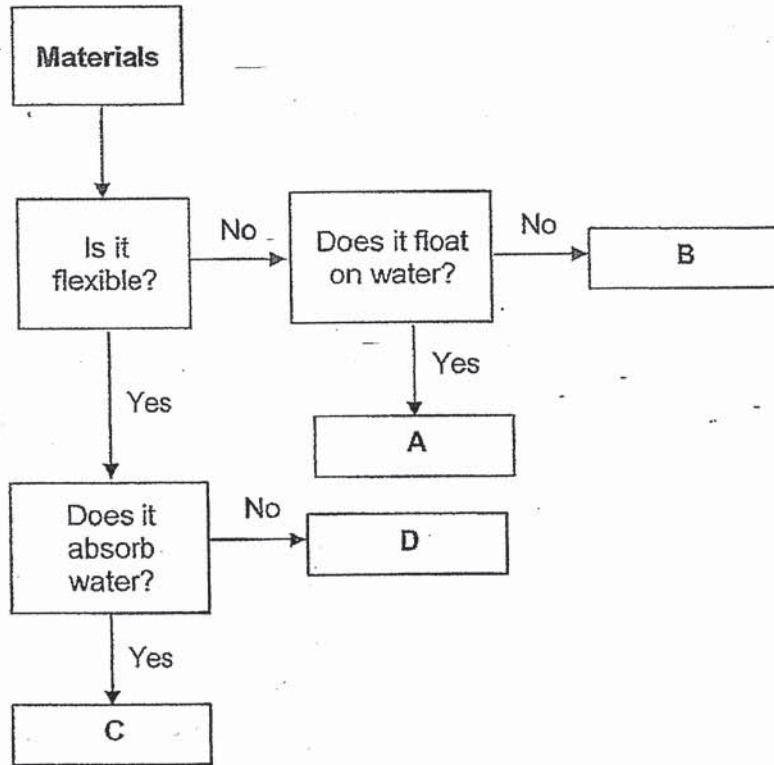

Based on the flowchart given, which material, A, B, C or D, is most suitable for making part X of the camping tent shown?



- (1) A
- (2) B
- (3) C
- (4) D

17. Study the picture of a watch.

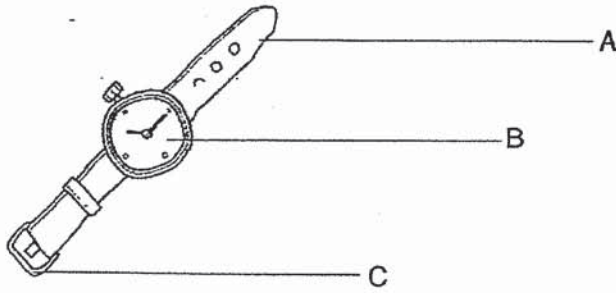

Which of the following materials best represent parts A, B and C?

	A	B	C
(1)	leather	glass	metal
(2)	glass	plastic	metal
(3)	metal	glass	leather
(4)	plastic	leather	plastic

18. Marcus used a metal measuring tape as shown to measure the width of his bed.

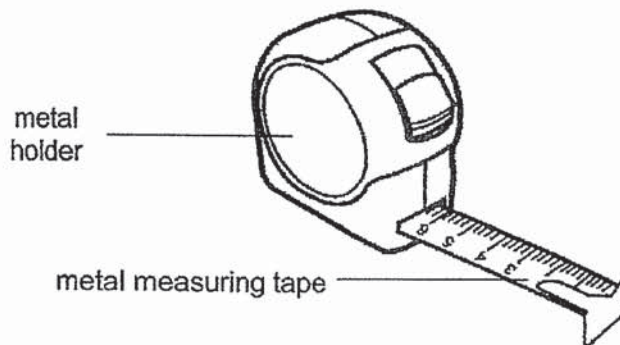

Which property of the metal measuring tape allows it to be rolled up inside the metal holder?

- (1) Strength
- (2) Flexibility
- (3) Waterproof
- (4) Transparency

19. Four students made the following comments about a system.

Alicia: All systems are man-made.

Bala: A system can be made up of two or more parts. —

Chloe: An eraser is a system because it can be used to erase things.

David: A system cannot carry out its function well if one of its parts is missing.

Which two students' comments are correct?

- (1) Alicia and Bala
- (2) Bala and David
- (3) Alicia and Chloe
- (4) Chloe and David

20. The diagram shows some parts of the digestive system.

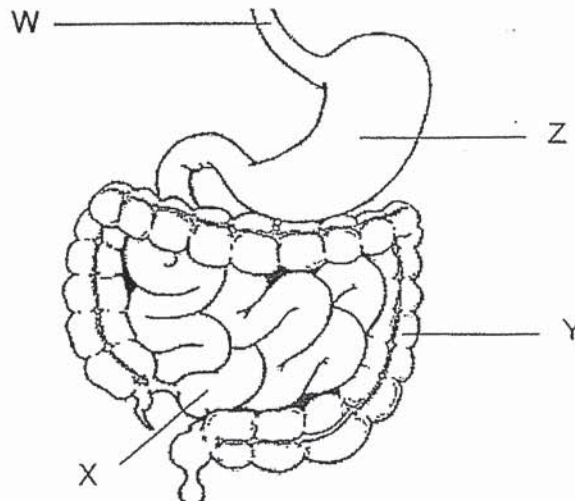

Which part, W, X, Y or Z, absorbs water from the undigested food?

- (1) W
- (2) X
- (3) Y
- (4) Z



21. Xue Ling conducted an experiment to find out if the size of biscuits affect how fast they are being digested. The same amount of digestive juices was added to each set up.

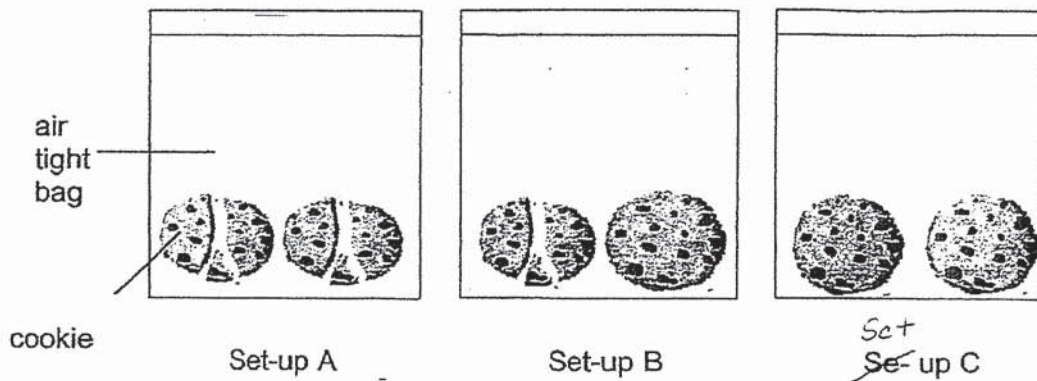

Arrange the set-ups in order, beginning with the one with cookies that will be digested the slowest.

- (1) A, C, B
- (2) A, B, C
- (3) B, C, A
- (4) C, B, A

22. The table shows the organs that can be found in the human body system.

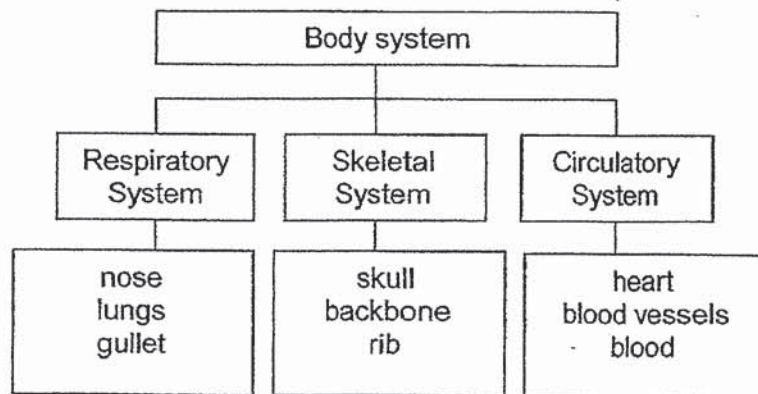

Which of the following organs is **incorrectly** matched to its system?

- (1) nose
- (2) skull
- (3) gullet
- (4) rib cage

23. Jackson held a string puppet with his fingers as shown. He moved the strings attached to the hands and legs of the puppet up and down to make it move.

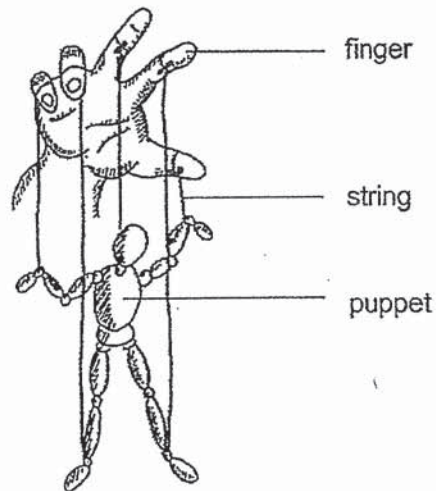

Which two organ systems in the human body work together in the same way as the string puppet to make it move?

- (1) skeletal and muscular
- (2) circulatory and skeletal
- (3) digestive and muscular
- (4) muscular and respiratory

24. Observe the pineapple plant.

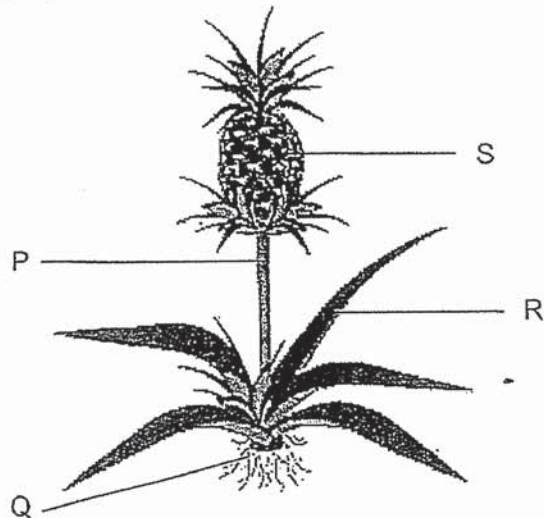

Which part of the plant helps to support the plant?

- (1) P
- (2) Q
- (3) R
- (4) S

## 25. Study Plants F and G.

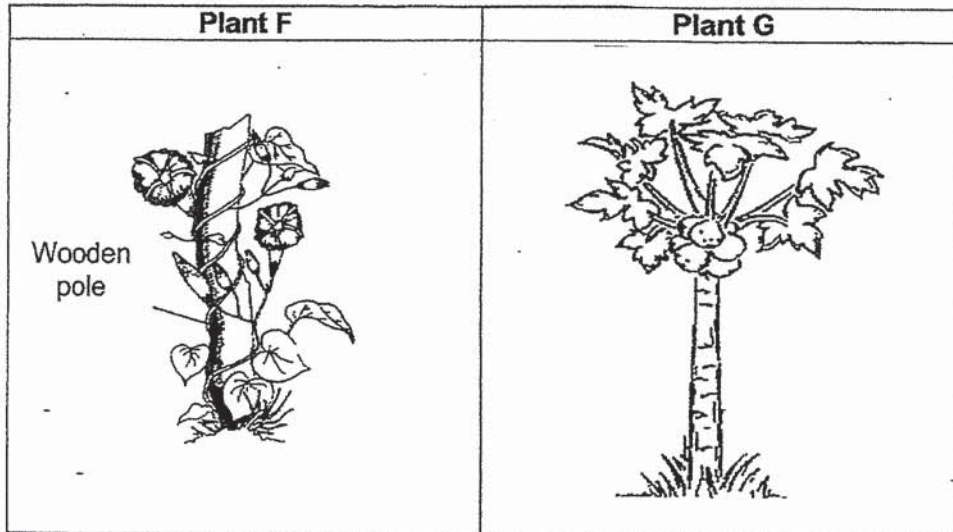

Which of the following two statement(s) about Plants F and G are correct?

- A They have weak stems.
  - B They reproduce by seeds.
  - C They can make their own food.
  - D Only Plant F is a flowering plant.
- (1) A and B  
 (2) A and D  
 (3) B and C  
 (4) C and D

## 26. Study the set-up.

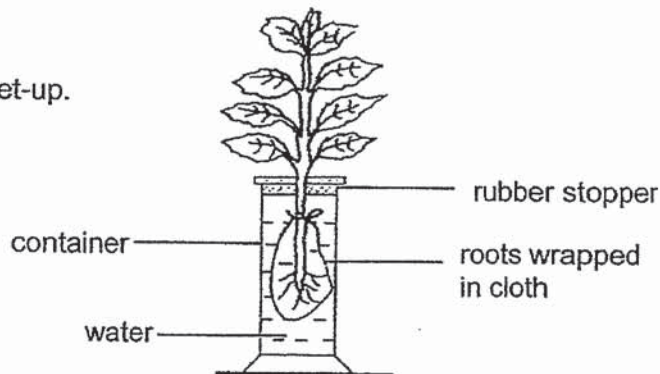

Which of the following correctly shows the change in the amount of water in the container after two days?

- (1) It will increase.
- (2) It will decrease.
- (3) It will remain the same.
- (4) It will increase and then decrease.

27. Emily placed the following three set-ups near a window for three days.

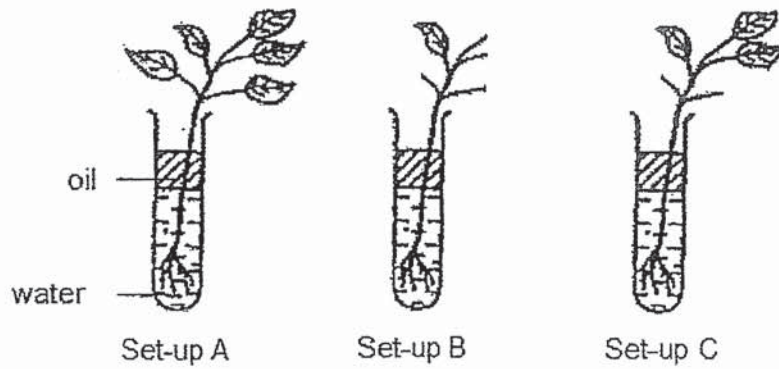

Which of the following graphs shows the correct amount of water left in each set-up at the end of three days?

(1)

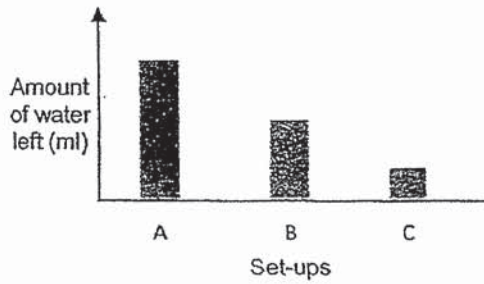

(2)

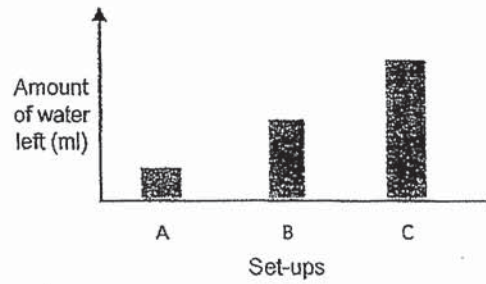

(3)

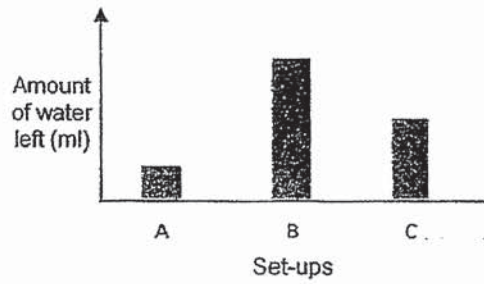

(4)

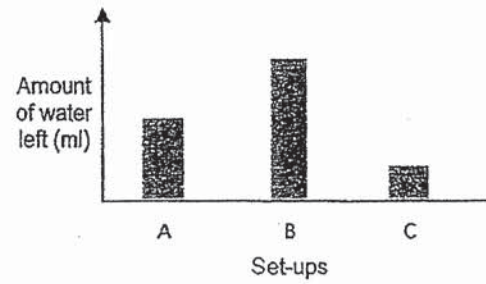

28. Uncle Lim tied a plastic bag over his balsam plant as shown and placed it inside a dark cupboard. He watered it daily.

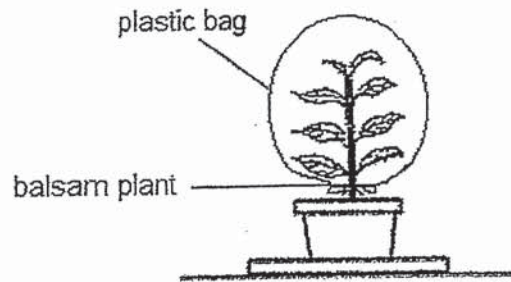

A few days later, the plant died. Why did the plant die?

- (1) The plant did not have enough air.
- (2) The plant had too much warmth in the cupboard.
- (3) The leaves of the plant did not get sufficient water.
- (4) The plant could not reproduce as it has no flowers.

End of Booklet A



# Anglo-Chinese School (Junior)



## SEMESTRAL ASSESSMENT 2 (2019)

PRIMARY 3

SCIENCE

BOOKLET B

Thursday

31 October 2019

1 h 45 min

Name \_\_\_\_\_ ( ) Class: 3.( ) Parent's Signature: \_\_\_\_\_

### INSTRUCTIONS TO PUPILS

- 1 Do not turn over the pages until you are told to do so.
- 2 Follow all instructions carefully.
- 3 There are 13 questions in this booklet.
- 4 Answer ALL questions.
- 5 The marks are given in the brackets [ ] at the end of each question or part question.

Booklet	Possible Marks	Marks Obtained
A	56	
B	44	
Total	100	

---

This question paper consists of 15 printed pages (inclusive of cover page).



**Booklet B (44marks)**

For questions 29 to 41, write your answers in this booklet.

The number of marks available is shown in brackets [ ] at the end of each question or part question. (44marks)

29. The picture shows an aquarium with living and non-living things.

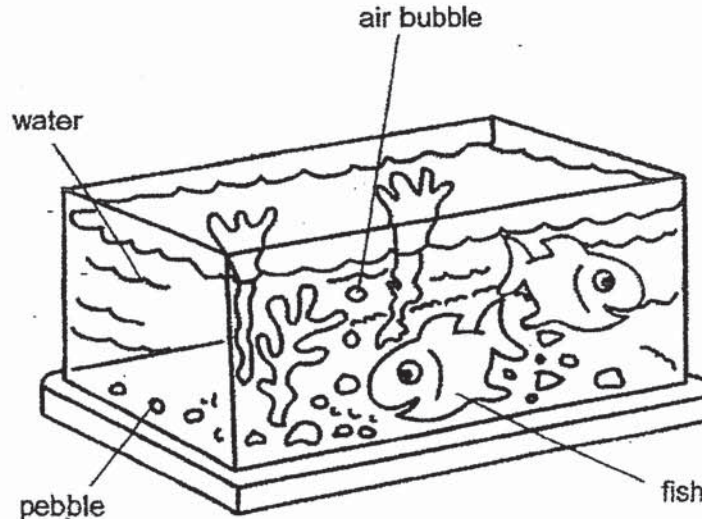

- (a) Classify all the four things in the aquarium in the table. [1]

Living things	Non-living things

- (b) A few days later, an air pump is added into the aquarium. Based on the table above, which group will you classify it under? [1]

\_\_\_\_\_







- (c) After a few weeks, fish eggs are observed in the aquarium. State the characteristic of living things shown based on this observation. [1]

\_\_\_\_\_

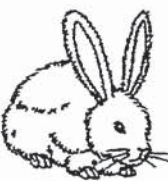
\_\_\_\_\_

SCORE	3
-------	---

30. Study the classification table carefully.

Group M		Group N	
			
woodpecker	rabbit	stick insect	doll
			
windmill	snail	balloon	car

(a) Each group has a thing that is **incorrectly** classified. Name these two things. [1]

i. Group M: \_\_\_\_\_

ii. Group N: \_\_\_\_\_

(b) State a difference between the characteristics of the things that have been classified correctly in groups M and N. [1]

\_\_\_\_\_

\_\_\_\_\_

(c) Give another example of things that can be classified under group M and group N. [1]

i. Group M: \_\_\_\_\_

ii. Group N: \_\_\_\_\_

SCORE	3
-------	---

31. The table shows the characteristics of four plants, A, B, C and D. A tick (✓) shows that the plant has that characteristic.

Characteristics	Plants			
	A	B	C	D
Has flowers	✓		✓	
Grows in water		✓	✓	

- (a) State all the characteristics of Plant A. [1]

---



---

- (b) Using the information in the table above, classify plants A, B, C and D, in the classification chart below. [2]

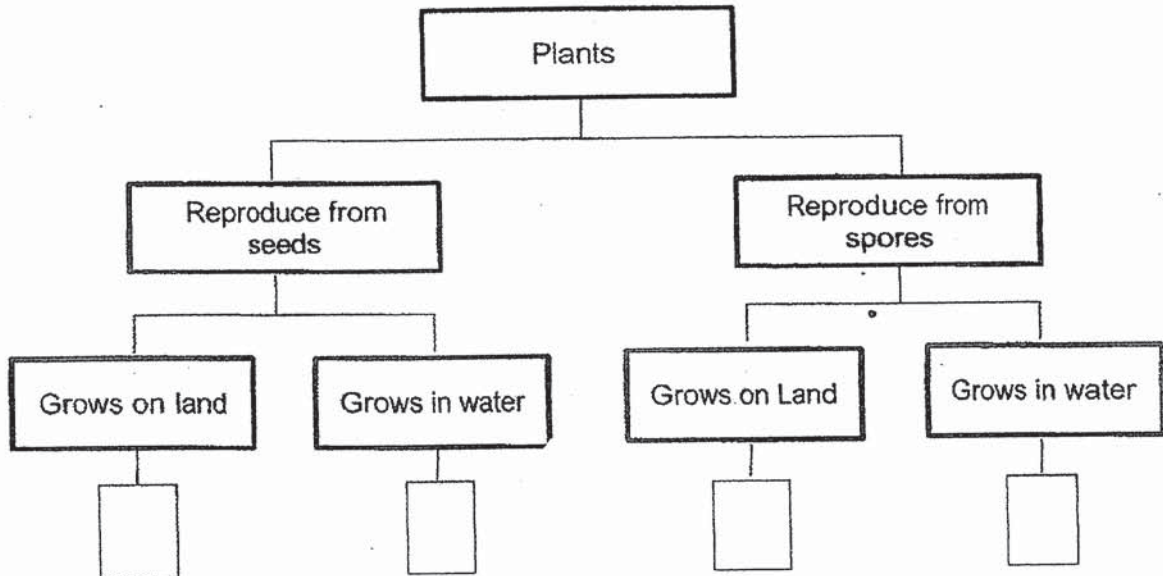

SCORE	3
-------	---



32. Ryan spots a plant in his garden. It grows around a stick.

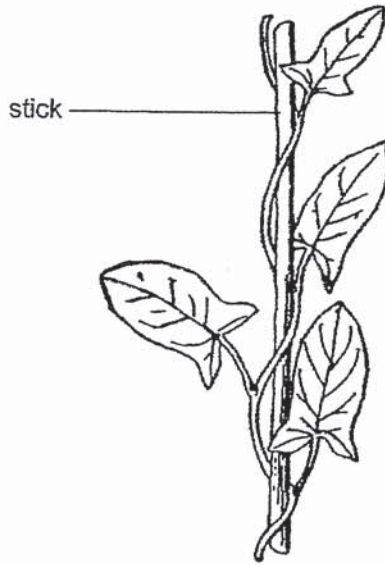

(a) Tick (✓) the statement that best explains the purpose of the stick. [1]

Statements	Tick (✓)
It holds the leaves.	
It anchors the plant.	
It supports the plant.	

(b) Explain clearly why the plant needs to grow around the stick. [1]

---



---

(c) How do the leaves help the plant make food? [1]

---

(d) Name the parts, (i) and (ii), of the leaf. [1]

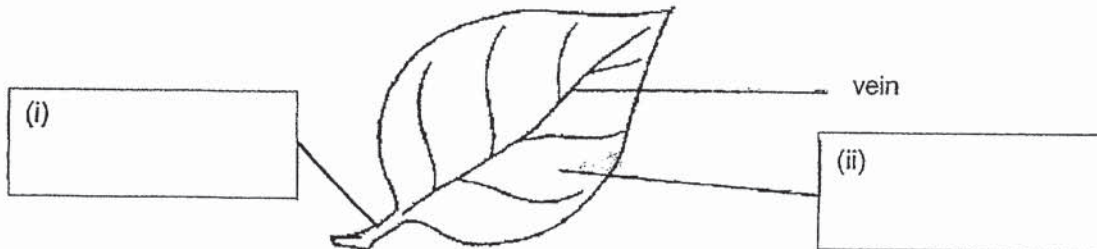

SCORE	4
-------	---

33. Study the following flow chart.

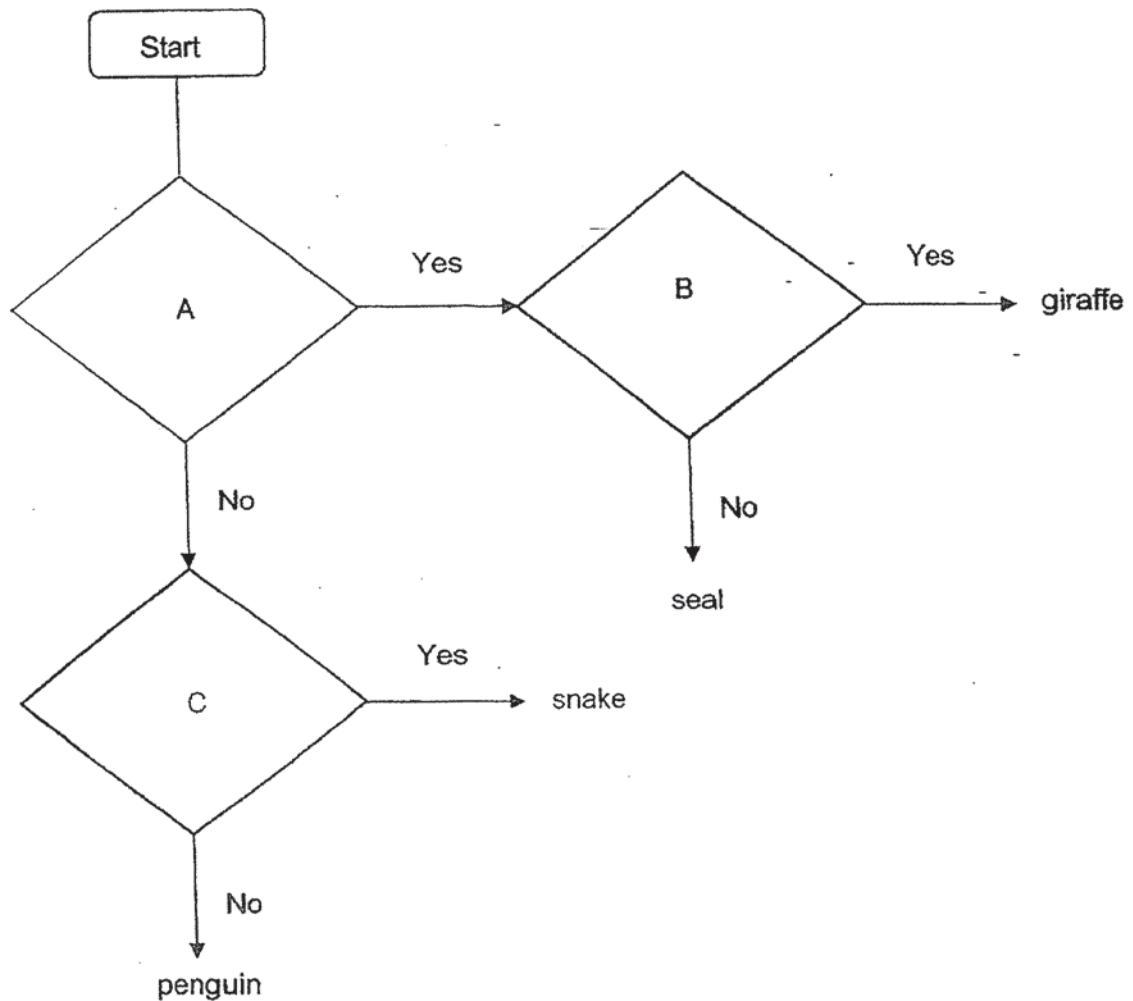

- (a) Match the questions in the box below to the correct letters A, B and C, in the flowchart above. Each letter can only be used once.

[1]

Questions	A, B or C
Can it swim?	
Does it have scales?	
Does it live on land only?	
Does it give birth to its young alive?	

- (b) Name an animal that can replace 'snake' in the flowchart.

[1]

- (c) In the table, classify penguin, snake, seal and giraffe, so that there are only two animals in each group. State clearly the headings for each group.

[1]

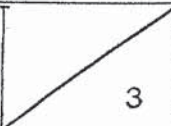
SCORE	
	3

34. The following table shows the characteristics of three animals, X, Y and Z. A tick (✓) shows that the animal has that characteristic.

Characteristic	Animal X	Animal Y	Animal Z
Can swim	✓	✓	✓
Live on land and in water	✓		✓
Has scales		✓	✓
Breathe through gills		✓	

- (a) State one difference between Animal Y and Animal Z. [1]

---



---

- (b) Which animal group does Animal Y most likely belong to? [1]

---

- (c) (i) The diagram below shows a frog.



- Using the information given in the table above, which animal, X, Y or Z, best represents a frog? [1]

Animal \_\_\_\_\_

- (ii) On the diagram above, label the part that allows the frog to breathe underwater. Draw a line touching the part and name it. [1]

SCORE	4
-------	---

35. Amy conducted an experiment. She sprinkled the same amount of water on four slices of bread, A, B, C and D, and placed each of them in similar sealed bags. She then placed each bag in four rooms of different temperatures for three days.

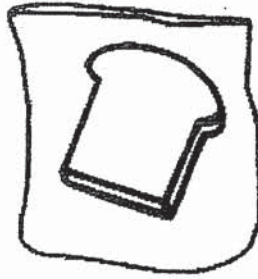

After three days, she recorded the amount of mould that grew on each slice of bread in the table.

Bread	Temperature of the room ( $^{\circ}\text{C}$ )	Amount of mould (units)
A	10	5
B	15	7
C	20	12
D	30	25

- (a) What was the aim of Amy's experiment? [1]

---



---

- (b) Describe the relationship between the temperature of the room and the amount of mould that grew on the slice of bread. [1]

---



---

- (c) Name another variable that Amy should keep the same to make sure that the experiment is a fair test. [1]

---

SCORE	3
-------	---



36. Zachary set up an experiment to test the strength of four planks made of different materials, A, B, C and D.

He set up the experiment as shown. He stacked metal blocks one at a time on each plank until the plank broke.

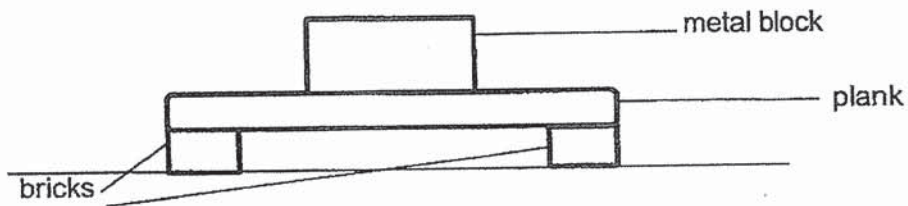

He recorded in the graph the maximum number of metal blocks each plank could hold before breaking.

- (a) Draw the bar graph for plank C which was the weakest plank in the graph below. [1]

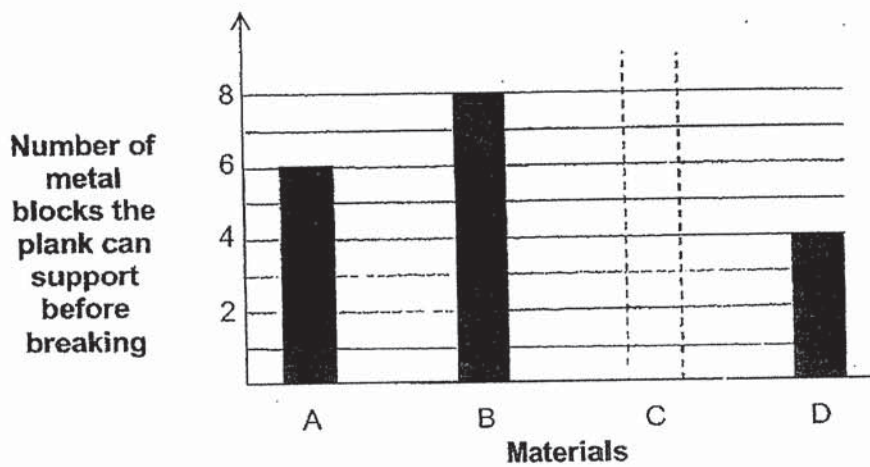

- (b) Which material, A, B, C or D, can be best used to build a bookshelf to store heavy books? Explain your answer. [1]

---



---

- (c) Zachary also wants to build an outdoor dog kennel as shown.



Besides the property of strength, which other important property must the material have? [1]

---

SCORE	3
-------	---

37. Bryan set up an experiment as shown to compare two strips made of different materials, Y and Z. The strips have the same thickness. He placed similar containers with 200ml of water on the strips as shown in the diagram.

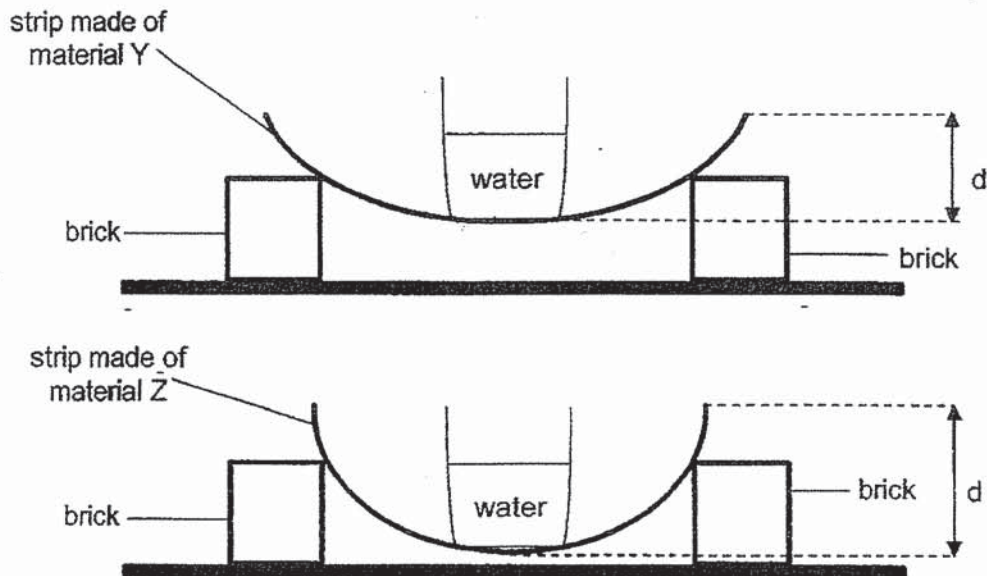

He measured the distance,  $d$ , between the highest point and lowest point of the strip. The table shows his results.

Material	$d$ (cm)
Y	3
Z	7

- (a) What is the aim of Bryan's experiment? [1]
- \_\_\_\_\_
- (b) What could Bryan conclude about material Y and material Z from this experiment? [1]
- \_\_\_\_\_
- \_\_\_\_\_
- (c) State another variable that must be kept constant to ensure a fair test. [1]
- \_\_\_\_\_
- (d) Bryan repeated the experiment using 100ml of water instead. What will happen to distance  $d$ ? [1]
- \_\_\_\_\_

SCORE	4
-------	---

38. The table shows the amount of digested food leaving different parts of the digestive system. The different parts are not arranged in order.

Parts of the digestive system	Amount of digested food (units)
Small Intestine	65
Mouth	10
Part Q	28
Part R	0

- (a) Name the substance that can be found in the mouth that helps to soften food. [1]

\_\_\_\_\_

- (b) Name parts Q and R. [1]

Part Q: \_\_\_\_\_

Part R: \_\_\_\_\_

- (c) Explain what happens to the digested food in the small intestine. [2]

\_\_\_\_\_

\_\_\_\_\_

SCORE	4
-------	---

39. The flow chart shows the main substances transported in the human body.

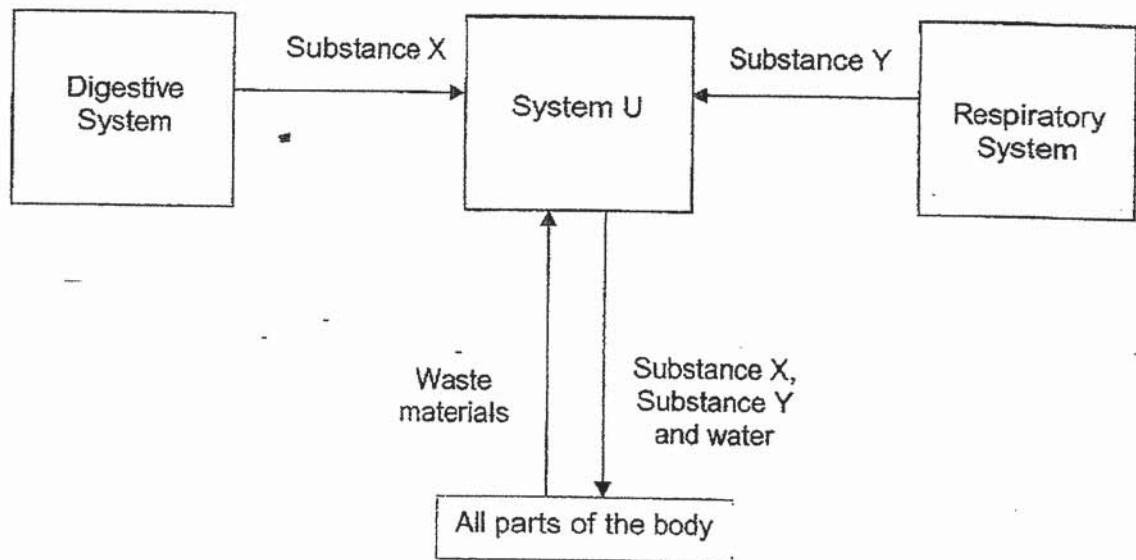

- (a) Name System U. [1]

System U: \_\_\_\_\_

- (b) Name substances X and Y. [1]

Substance X: \_\_\_\_\_

Substance Y: \_\_\_\_\_

- (c) State the function of the respiratory system. [1]

\_\_\_\_\_

\_\_\_\_\_

SCORE	3
-------	---



40. The picture shows the underside of a leaf. Part A can be seen under a microscope.

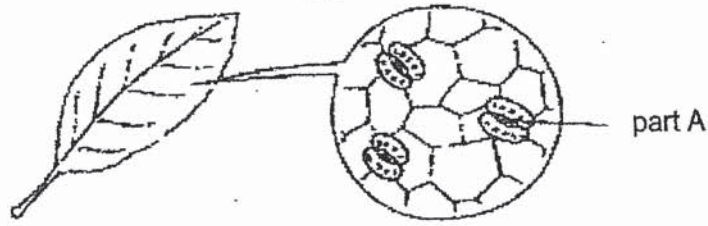

(a) Name part A and state its function.

[2]

<b>Part A</b>	
<b>Function</b>	

Dylan wants to find out if the number of leaves plants have affect their growth.

He prepares the set-ups as shown. They are placed in the garden for the same amount of time and watered daily.

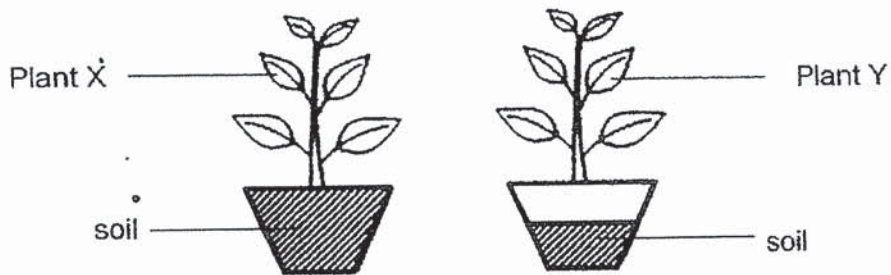

(b) What change(s) must he make to the set-ups to test his aim?

[2]

---



---

SCORE	4
-------	---



41. Potato plants produce flowers during the end of their growing season. They are known as underground stems.

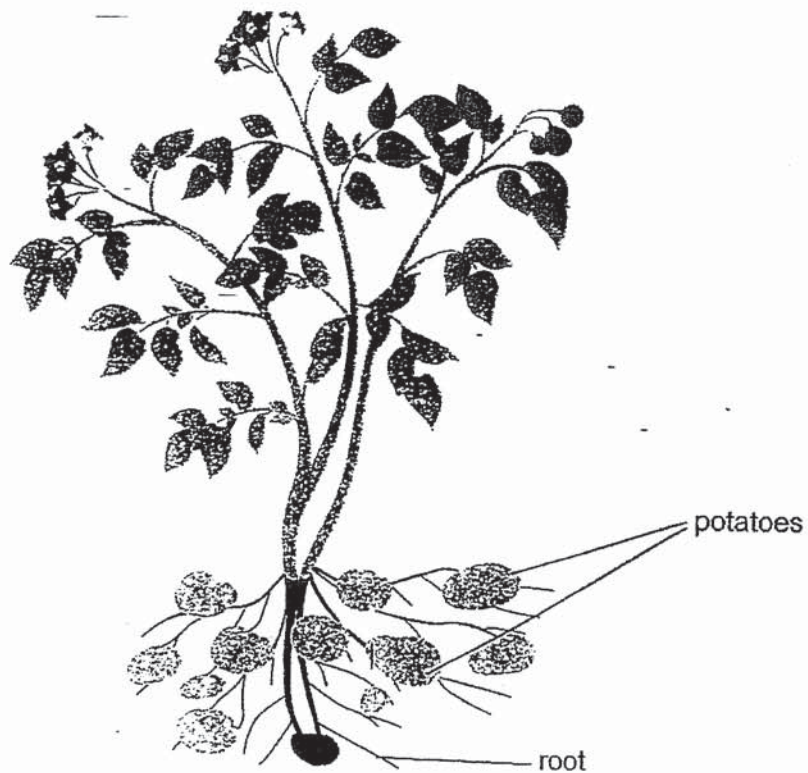

- (a) State how potato plants reproduce. [1]

---

- (b) All the roots of the potato plant are removed. Will the plant survive? Explain your answer. [1]

---



---

- (c) State another function of the roots. [1]

---

End of Paper

SCORE	3
-------	---



## ANSWER KEY

**YEAR : 2019**  
**LEVEL : PRIMARY 3**  
**SCHOOL : ANGLO-CHINESE SCHOOL(JUNIOR)**  
**SUBJECT : SCIENCE**  
**TERM : SA2**

### BOOKLET A

Q1	2	Q2	2	Q3	3	Q4	1	Q5	2
Q6	3	Q7	2	Q8	2	Q9	3	Q10	4
Q11	2	Q12	4	Q13	1	Q14	2	Q15	1
Q16	4	Q17	1	Q18	2	Q19	2	Q20	3
Q21	4	Q22	3	Q23	1	Q24	1	Q25	3
Q26	2	Q27	3	Q28	1				

### BOOKLET B

**Q29 (a)**

<b>LIVING THINGS</b>	<b>NON-LIVING THINGS</b>
Fish	Air bubble, water pebble

**(b) Non-living things**

**(c) Living things reproduce.**

**Q30 (a) Group M: Windmill**

**Group N: Stick insect**

**(b) Group M needs air, food and water to survive but not Group N.**

**(c) Group M: Caterpillar**

**Group N: Robot**

**Q31 (a) It has flowers and does not grow in water.**

**(b) A, C, D, B**

**Q32 (a) It supports the plant**

(b) It has a weak stem and could not grow upright to trap more sunlight to make food for the plant.

(c) The leaves trap sunlight to make food.

(d)(i) Leaf stalk

(ii) Leaf blade

Q33 (a)

Questions	A, B or C
Can it swim?	
Does it have scales?	C
Does it live on land only?	B
Does it give birth to its young alive?	A

(b) Goldfish

(c)

Have hair	Does not hair
Seal, Giraffe	Penguin, Snake

Q34 (a) Animal Y breathe through gills but no Animal Z.

(b) Fish

(c)(i) Animal: X

(ii)

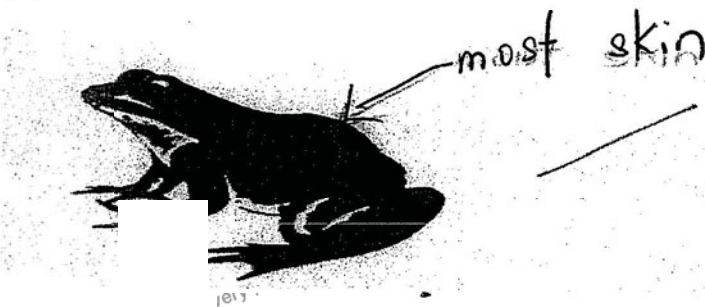

Q35 (a) It is to find if mould grows faster in temperature that is higher or lower.

(b) As the temperature is lower, the number of mould growing on the bread would be slower.

(c) The type of bread

Q36 (a)

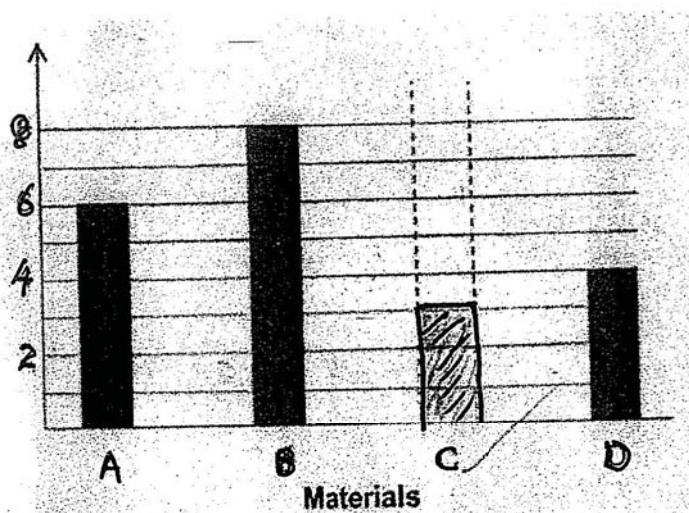

(b) Material B. It is the strongest and is able to withstand heavy weight.

(c) It must be waterproof.

Q37 (a) It is to find out if which material, X or Z is more flexible.

(b) Material Z was more flexible than material Y

(c) The distance between the 2 bricks.

(d) It will decrease.

Q38 (a) Saliva

(b) Part Q: Stomach

Part R: Large Intestine

(c) It will pass through the intestine walls into the bloodstream to all parts of the body through the circulatory.

Q39 (a) em U: Circulatory system

(b) Substance X: Digested food

Substance Y: Oxygen

(c) It carries out the exchanging of gases between the body and the surroundings.

Q40 (a) Part A Stomata

Function To exchange gases between the plant and its surroundings.



(b) He should fill the soil of plant Y the same amount as plant X and remove some leaves.

Q41 (a) They reproduce by seeds

(b) No. The plant cannot absorb water and mineral salt.

(c) They hold the plant firmly to the ground.

4  
END