

**CHIJ ST. NICHOLAS GIRLS' SCHOOL  
SEMESTRAL ASSESSMENT 2 2005  
PRIMARY 3 SCIENCE**

Name: \_\_\_\_\_ ( . )

Class : Primary 3 ( . )

Date : 17 October 2005

Duration : 1 hr 45 min

---

**SECTION A : (30 X 2 marks)**

For each question, there is one correct answer. Choose the correct answer and shade the number (1, 2, 3 or 4) on the **Optical Answer Sheet (OAS)** provided.

1. Look at the table below. Which group is placed correctly?

	Non-living things	Living things
(1)	coin	water
(2)	ant	seedling
(3)	seedling	stone
(4)	water	seedling

2. A sunflower plant cannot survive in a desert because it is unable to get enough \_\_\_\_\_ there.

- A. Air
- B. Water
- C. Sunlight

- (1) A only
- (2) B only
- (3) A, B and C
- (4) A and C only

3. Which one of the following objects is made from something that has never been alive?

- (1) eraser
- (2) metal tray
- (3) cotton wool
- (4) leather belt

4. A magnet was hung from a retort stand as shown in the diagram below.

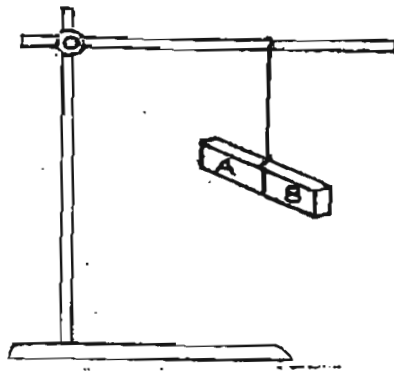

When the magnet came to rest, it will lie in a \_\_\_\_\_ direction.

- (1) north
- (2) east
- (3) north-south
- (4) north-east

5. Two examples of fungi are \_\_\_\_\_ and \_\_\_\_\_.

- (1) fern, toadstool
- (2) earthworm, ants
- (3) rose, mushroom
- (4) mould, yeast

6. The Venus flytrap is a plant that captures insects by snapping its two leaves shut like a shell when an insect walks on it. The diagram below shows how a Venus flytrap captures a fly.

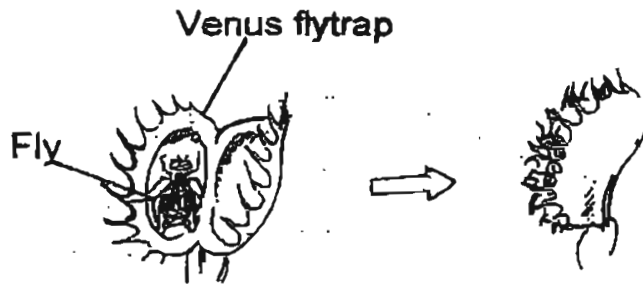

What characteristic(s) of living things is/are illustrated here?

- A: Living things need food to survive
- B: Living things can move by themselves
- C: Living things can respond to changes around them

- (1) A only
- (2) A and C only
- (3) B and C only
- (4) None of the above

7. The animals below are grouped according to their outer coverings.

A  
duck  
eagle

B  
prawn  
crab

C  
monkey  
lion

D  
Guppy  
goldfish

In which group would you put the "snail" ?

- (1) A
- (2) B
- (3) C
- (4) D

8. Study the classification table below.

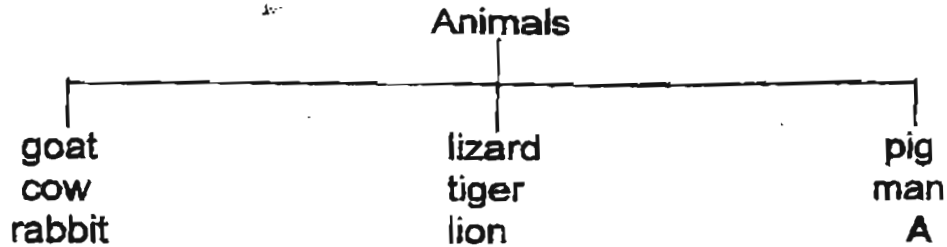

Which one of the following animals can "A" be?

- (1) deer
- (2) duck
- (3) zebra
- (4) leopard

9. Which animals are most likely to be found in the place shown below?



- A: Rats
- B: Dragonflies
- C: Houseflies
- D: Cockroaches

- (1) A, B and D
- (2) A, B and C
- (3) A, C and D
- (4) B, C and D

10. Amy told the police, "There were loud cries for help. Many people were running out of the building and the air smelt of burning wood."

How many senses did Amy use?

- (1) One
- (2) Two
- (3) Three
- (4) Four

11. Which one of the following correctly shows the complete food path taken by food particles during the process of digestion?

- (1) mouth → stomach → large intestine → small intestine
- (2) mouth → gullet → small intestine → stomach → large intestine → anus
- (3) gullet → stomach → small intestine → large intestine → anus
- (4) mouth → gullet → stomach → small intestine → large intestine → anus

12. Which of the following objects are made from the same material?

- A: Tyre
- B: Brick
- C: Envelope
- D: Cardboard

- (1) A and B
- (2) A and D
- (3) B and C
- (4) C and D

13. Study the figure below. The part marked X is the

\_\_\_\_\_.

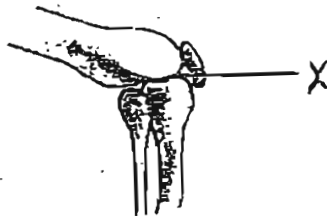

- (1) leg
- (2) joint
- (3) wrist
- (4) muscle

14. May is blindfolded and given a rose.



Which sense organ can she make use of to identify the rose?

- A: Skin
- B: Eyes
- C: Nose
- D: Tongue

- (1) D only
- (2) A and C
- (3) A, B and D
- (4) A, C and D

15. Four different materials of equal length and size are dipped into a dish filled with water as shown in the diagram below.

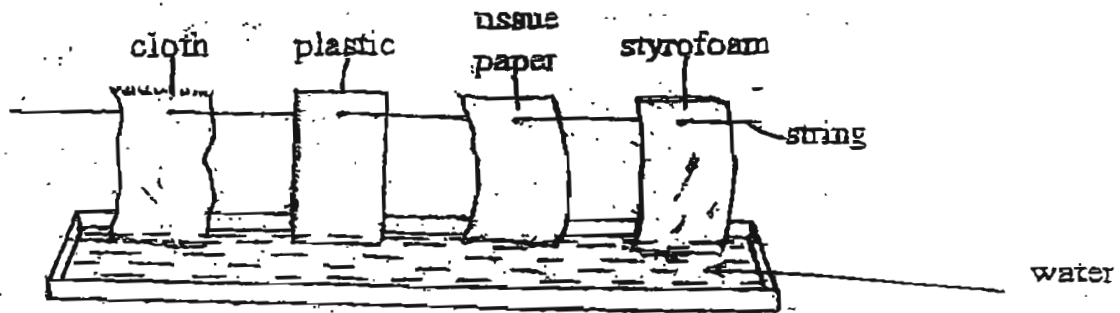

Which pair of materials will be completely wet after three hours?

- (1) cloth and styrofoam
  - (2) tissue paper and cloth
  - (3) tissue paper and plastic
  - (4) plastic and styrofoam
16. A magnet was brought near a tray which contains iron filings, sand, some paper clips and clay. Which of the following will be attracted by the magnet?

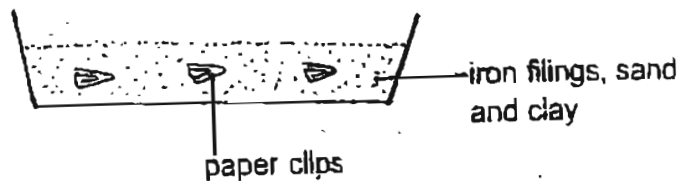

- A: Sand
- B: Clay
- C: Iron filings
- D: Paper clips

- (1) B only
- (2) C only
- (3) A and D
- (4) C and D

17. A match box containing an unknown object is placed on thin sheet of glass in the experimental set-up shown below.

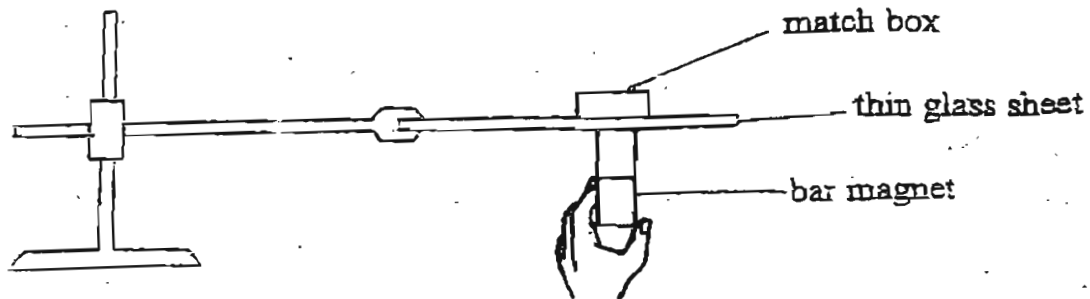

When the bar magnet moves, it is able to drag the match box along. Which is most likely to be found within the match box?

- (1) Marble
- (2) Gold ring
- (3) One-dollar coin
- (4) Steel ball bearing

18. The diagram below shows the life cycle of an animal. Which one of the diagrams given should be placed at "X" to complete the cycle?

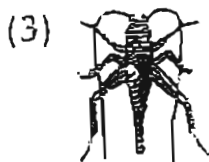
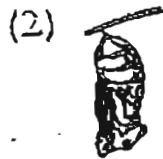
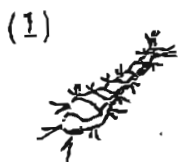
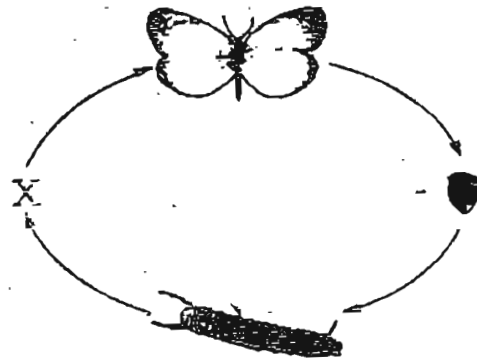



19. Which of the following trait(s) is/are not inherited from parents?

- A: Rolling of tongue
- B: Blood type
- C: Colour of hair
- D: Thumb print

- (1) A only
- (2) D only
- (3) C and D only
- (4) B, C and D only

20. Look at the table below and choose the object which is matched incorrectly with the materials which it can be made of.

		Materials				
		Fabric	Glass	Metal	Plastic	Wood
(1)	A pillow	✓				
(2)	A comb			✓	✓	✓
(3)	A cup		✓	✓	✓	
(4)	A window grille	✓	✓			✓

21.

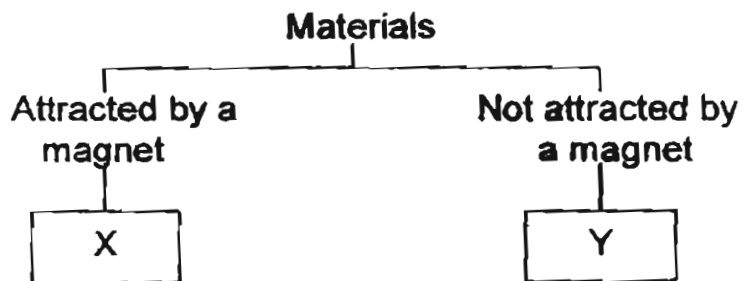

Which one of the following cannot be placed in group Y ?

- (1) Copper wire
- (2) Nickel wire ✓
- (3) Zinc sheet
- (4) Aluminium foil

22. Linda spit out the piece of apple she was eating when she saw a tiny worm crawling out from the core. Which of her sense(s) is/are at work?

- (1) sight
- (2) smell and taste
- (3) hearing and smell
- (4) sight and smell

23. Kevin placed a lizard each into 4 similar bottles, as shown in the diagrams below. In which bottle will the lizard survive the longest?

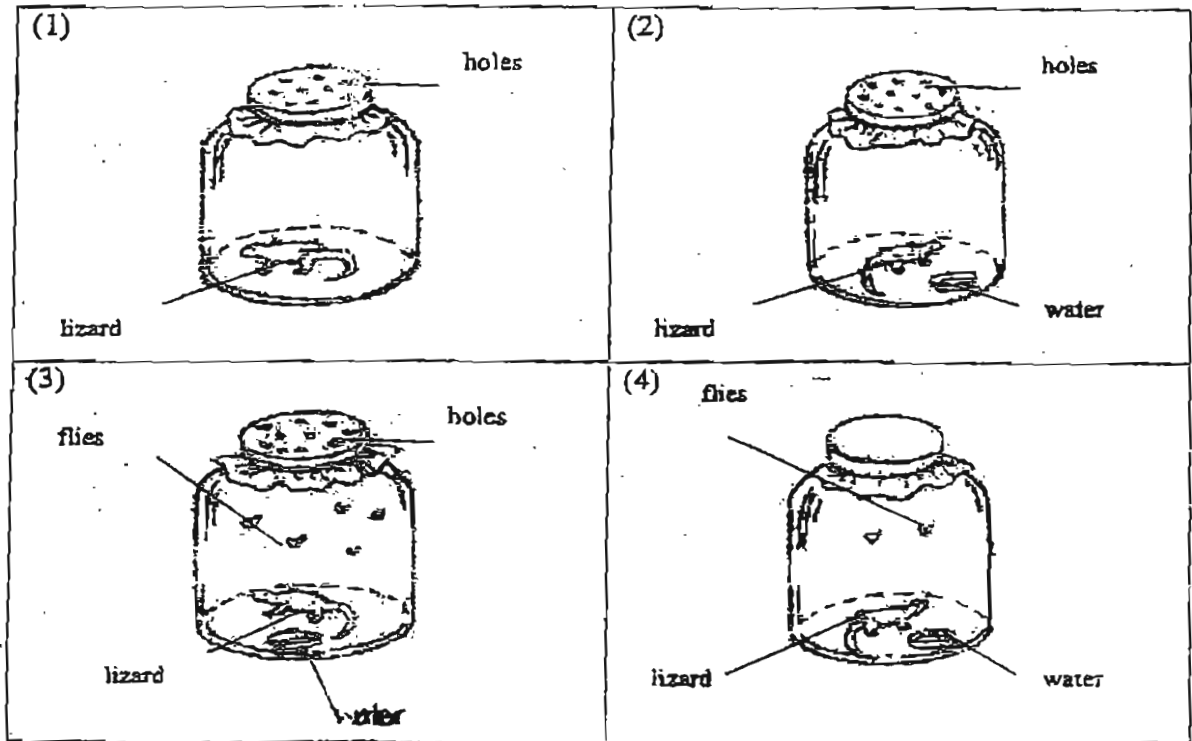

24. Kelly saw the following animals at the zoo. She described one of them as having a duck-beak, a fur coat and is a good swimmer with its webbed feet. Which one of the animals below did she describe?

(1)



spiny anteater

(2)



peacock

(3)



platypus

(4)



pigeon

25. Which of the following systems have to work together to enable movement?

- A: Digestive system
- B: Muscular system
- C: Skeletal system
- D: Respiratory system

- (1) A only
- (2) A, B and C
- (3) B and D only
- (4) B and C only

26. A bar magnet is divided into four parts, A, B, C and D as shown in the figure below.

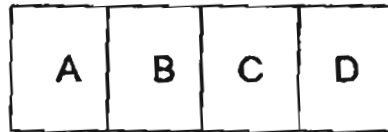

The magnet is then brought near to a number of paper clips. The number of paper clips attracted to each part of the magnet is recorded in the table below.

Part	Number of paper clips
A	10
B	4
C	5
D	3

Which part of the magnet is most likely to have the incorrect number of paper clips recorded ?

- (1) A
- (2) B
- (3) C
- (4) D

27. Study the picture shown below. Which of the following takes place when we bend our arms?

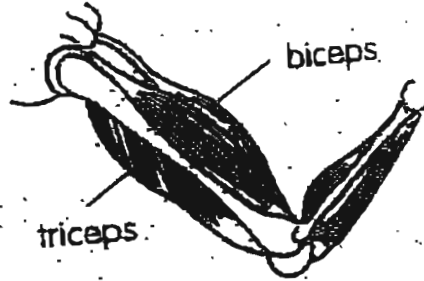

- (1) The triceps contract.
- (2) The biceps contract.
- (3) The biceps contract and the triceps relax.
- (4) The triceps contract and the biceps relax.

28. Study the diagram below carefully. The arrows below show the directions of movements of the magnets. Which of the following diagrams correctly shows the behaviour of two magnets when they are brought near each other?

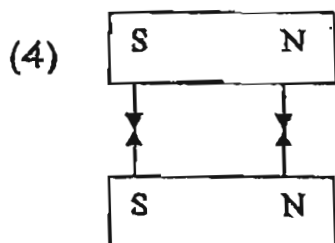
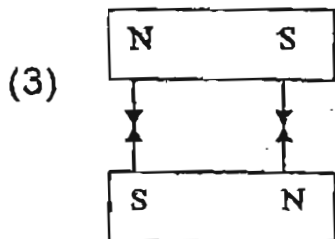
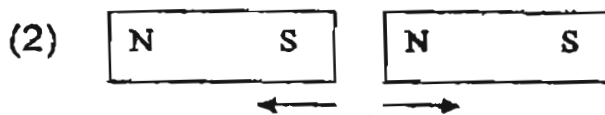
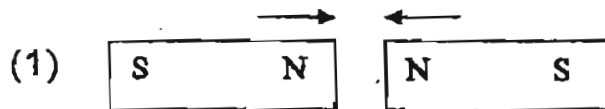

29. Which of the following organs belongs to the human respiratory system ?

1)



2)

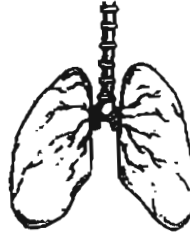

3)



4)



30. A button magnet was lowered between 2 rod magnets as shown below.

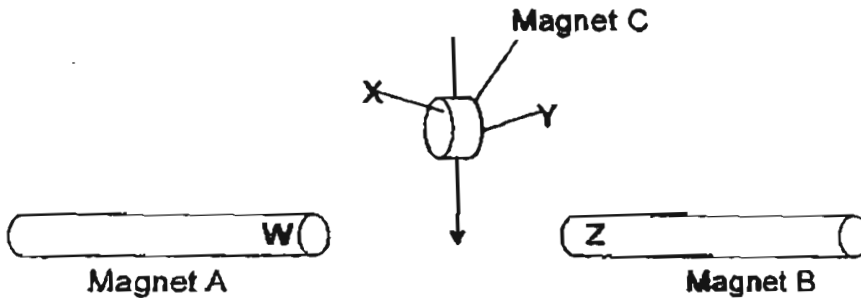

Magnet C moves towards magnet B.  
What could the poles of the magnets be?

	W	X	Y	Z
(1)	North	North	South	South
(2)	South	North	South	North
(3)	South	South	North	South
(4)	South	South	North	North

**Go To Booklet B**

Name : \_\_\_\_\_ ( )

Class : Primary 3 ( )

Date : 17<sup>th</sup> October 2005



**CHIJ ST. NICHOLAS GIRLS' SCHOOL  
SEMESTRAL ASSESSMENT 2- 2005**

**PRIMARY 3 SCIENCE  
BOOKLET B**

Section A	60	
Section B	40	
Total	100	

**16 Questions**

**40 Marks**

**Total time for Booklet A and B : 1 h 45 min**

**DO NOT OPEN THIS BOOKLET UNTIL YOU ARE TOLD TO DO SO.  
FOLLOW ALL INSTRUCTIONS CAREFULLY.**

Highest mark (Class)	
Average mark (Class)	

Highest mark (Level)	
Average mark (Level)	

**CHIJ ST. NICHOLAS GIRLS' SCHOOL  
SEMESTRAL ASSESSMENT 2 2005  
PRIMARY 3 SCIENCE**

**Section B (40 marks)**

For each question, write the answer in the space provided below.

31. Draw lines to match the adult animals to their young. (5 marks)

a) Adult animal:

Its young



butterfly



tadpole

b)



cockroach



larva

c)



frog



lamb

d)



mosquito



nymph

e)

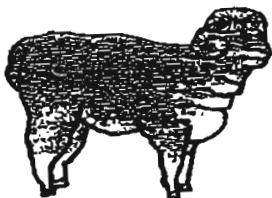

sheep



caterpillar

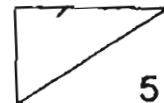



32.

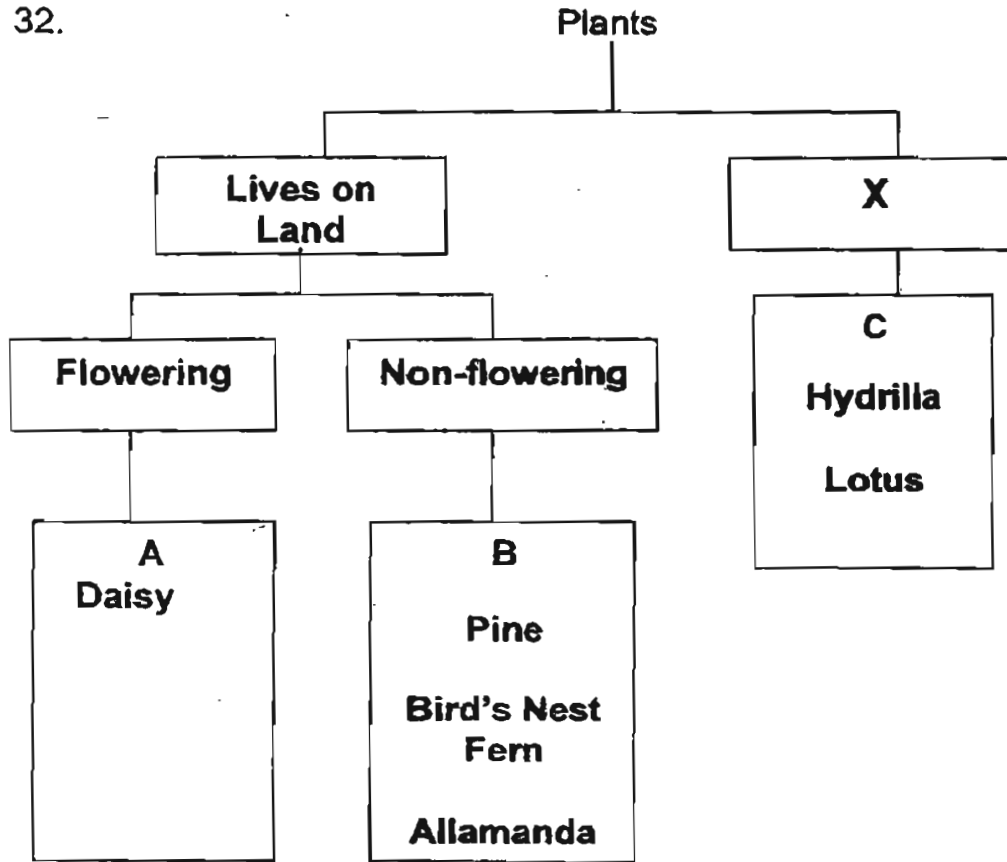

a) Write down a suitable heading for 'X'. (1 mark)

\_\_\_\_\_

bi) Which one of the above plants has been wrongly classified? (½ mark)

\_\_\_\_\_

bii) In which group, A, B, or C, does the plant in question (bi) belong? (1 mark)

Group \_\_\_\_\_

33. Label the parts of the onion plant below.

(1 mark)

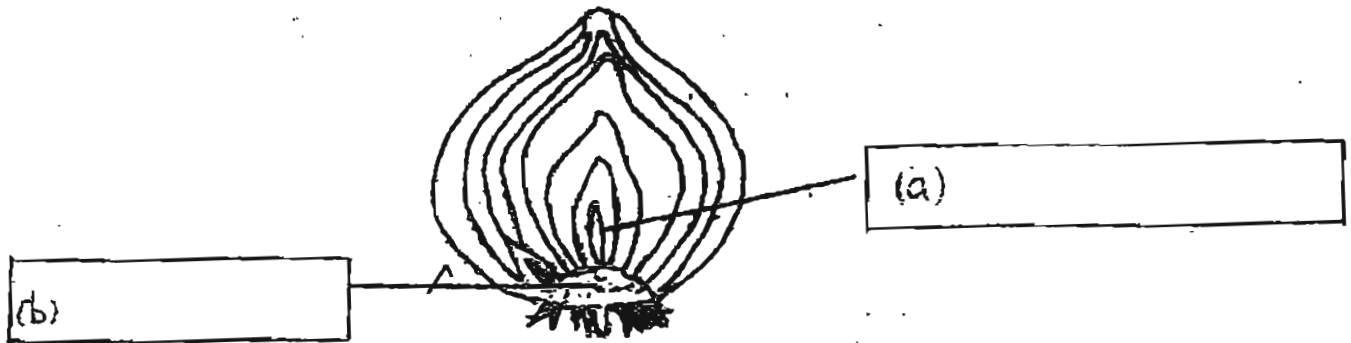

34. The figure below shows our digestive system.

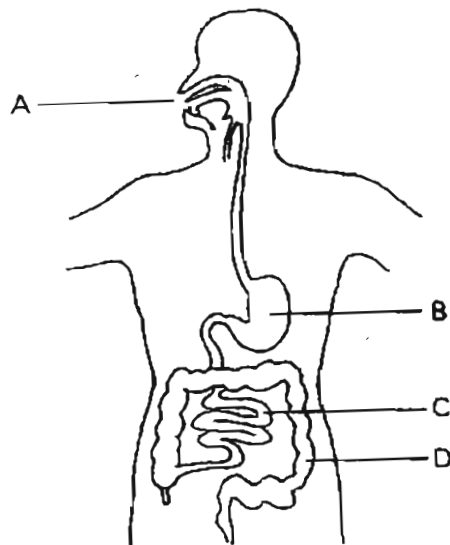

(a) Name the following parts of the digestive system. (1 mark)

(i) B : \_\_\_\_\_

(ii) D : \_\_\_\_\_

(b) In which part, A, B, C or D is digestion completed? (1 mark)

Part \_\_\_\_\_

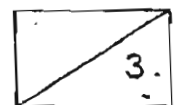

35. Classify the plants below such that it is placed next to their edible parts in the boxes provided. ( 2 marks )

<b>Chrysanthemum</b>	<b>Lettuce</b>
<b>Mangosteen</b>	<b>Sweet Potato</b>

Edible Plant Part	Plant
Flower	
Fruit	
Leaf	
Root	

36. The diagrams below show a pigeon and an ostrich.



a) Write down one similarity between the pigeon and ostrich. (1mark)

---

b) Write down one difference between the pigeon and ostrich. (1mark)

---

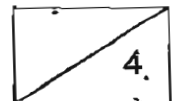

37. For each of the sentences below, write 'True' (T) or 'False' (F) in the boxes provided. (3 marks)

a) Tiny tubes in the stem of a plant carry water and mineral salts from the roots to other parts of the plants.

b) Plants can make food in the dark.

c) Plants only take in oxygen and give out carbon dioxide at night.

38a. Name the bones in the skeleton. (2 marks)

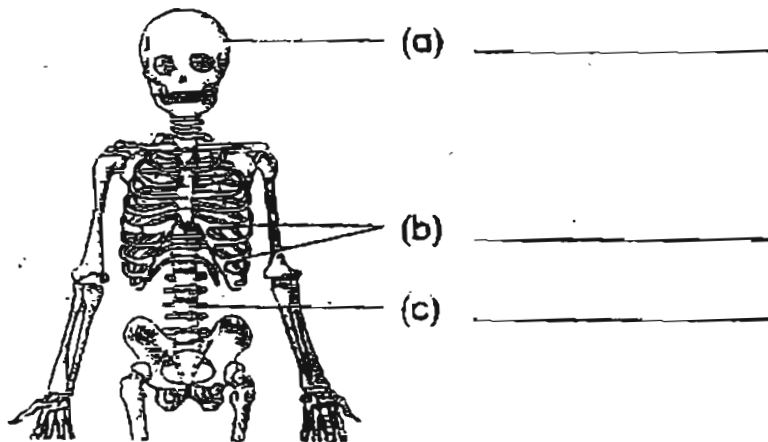

b. Name one function of the skeleton. (1 mark)

\_\_\_\_\_

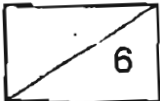

39. Some green bean seeds were placed in three different beakers to grow.

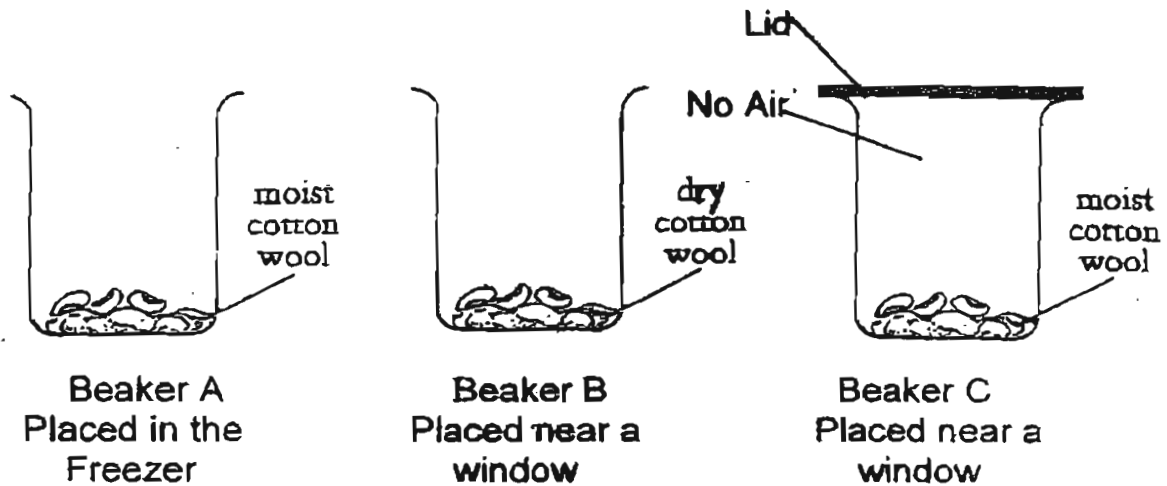

a) A week later, none of the green bean seeds germinated.  
 What does each seed need in order to germinate? (1 ½ mark)

Beaker A : \_\_\_\_\_

Beaker B : \_\_\_\_\_

Beaker C : \_\_\_\_\_

b) During germination where does the seedling get its food from? (1 mark)

\_\_\_\_\_

40. Fill in the blanks with suitable words from the box below. (3 marks)

telescope	harmful	microscope	useful	diseases
-----------	---------	------------	--------	----------

Micro-organisms means very tiny organisms. They are such small organisms that they can only be seen with the help of a

(a) \_\_\_\_\_ . Some examples of these micro-organisms are bacteria and yeast. A particular kind of bacteria called lactobacillus helps turn milk into cheese. Yeast is another

(b) \_\_\_\_\_ micro-organism that helps to make bread fluffy. But there are many harmful micro-organisms that cause

(c) \_\_\_\_\_ .

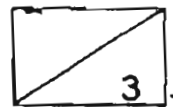

41. Anne hung 4 different magnets, P, Q, R and S from the ceiling to test the strength of the magnets as shown below.

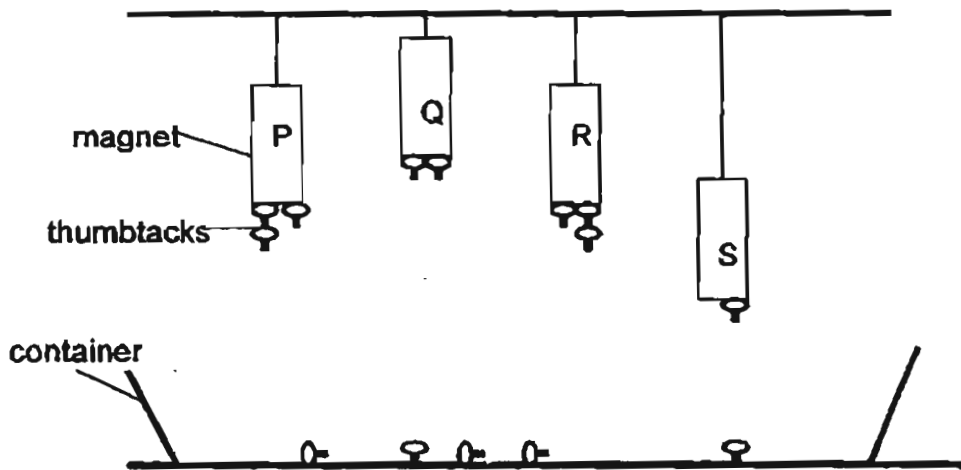

Based on the results shown above, study the statements given below and put a tick in the correct box. (3 marks)

	Statement	True	False	Not Possible To Tell
a)	Magnet P and Magnet R have the same magnetic strength.			
b)	Magnet Q is the strongest magnet.			
c)	Magnet S is made of copper.			

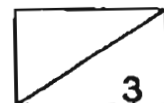

42. The diagrams below show how a papaya flower becomes a fruit but they are not in the correct order. Arrange them in the correct order. The last one has been done for you. (2 marks)

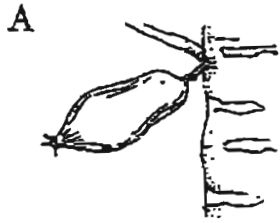

young papaya fruit

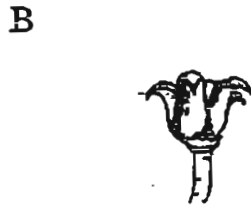

faded papaya flower

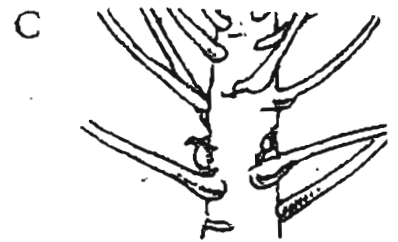

tiny papaya fruit



petals of flower dropping



ripe papaya fruit

The correct order is





43. Study the flow chart given below carefully.

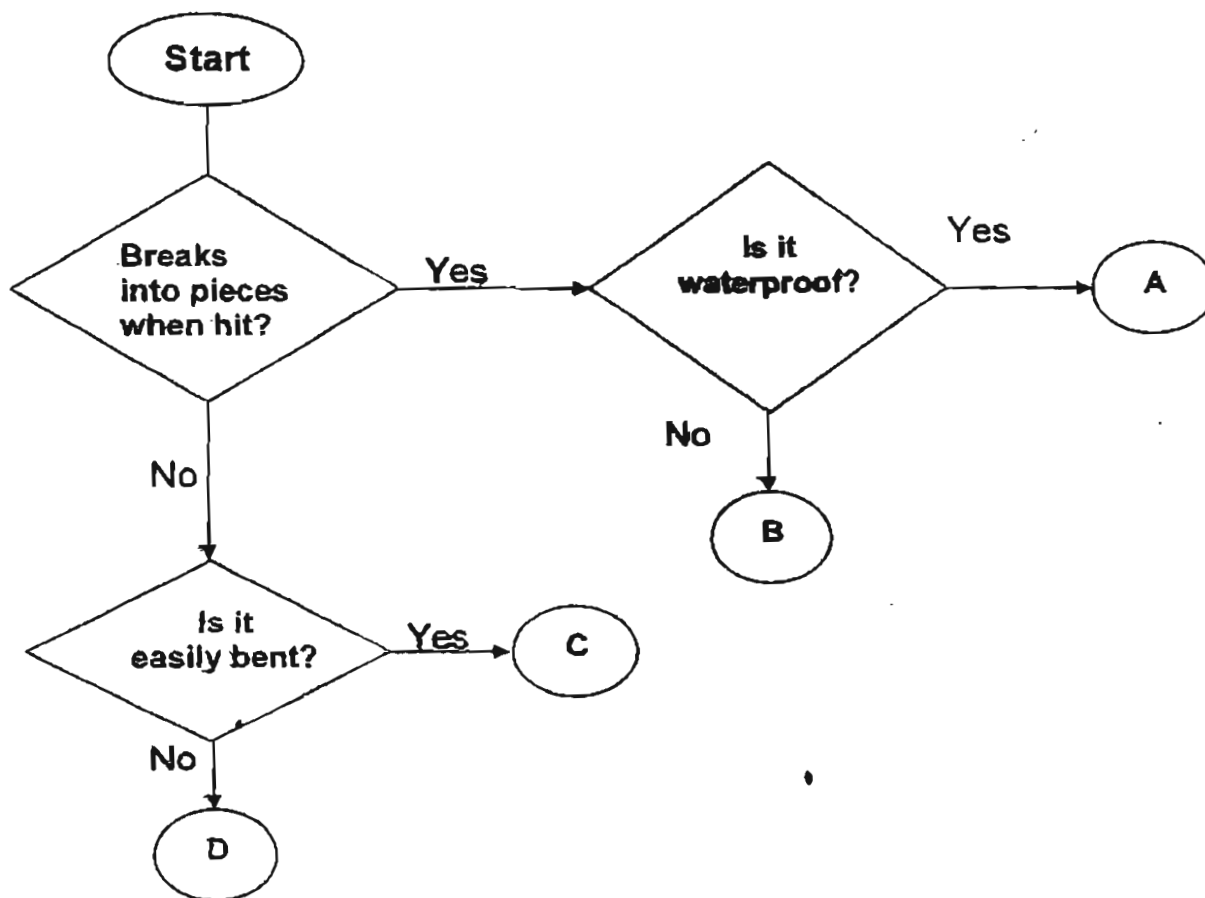

In which group A, B, C or D would you place the following objects?  
( 3 marks )

(a) Metal ruler \_\_\_\_\_

(b) Glass rod \_\_\_\_\_

(c) Rubber hose \_\_\_\_\_

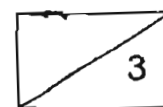

44. Shan Shan set up an experiment as shown below.

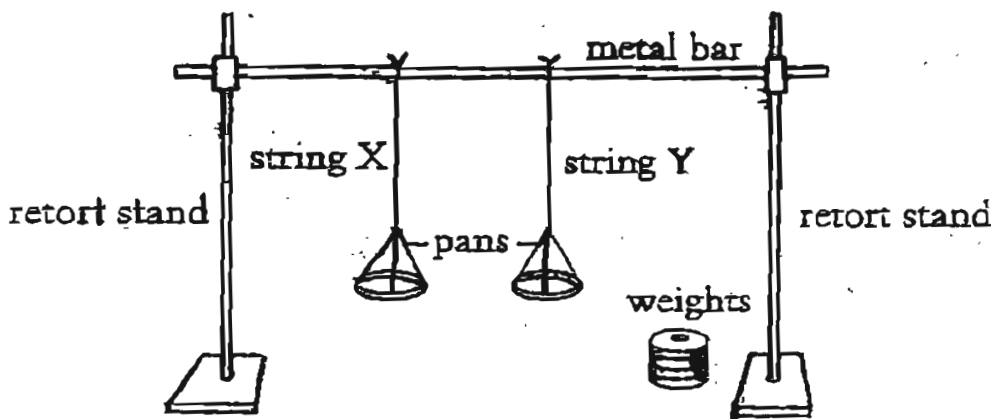

She tested the strengths of two strings, X and Y, by adding weights to both of them until they broke. She recorded the number of weights required before the strings broke in the table below.

String	X	Y
Number of weights required before string broke	5	10

a) If the strings were made of cotton and nylon, identify the material each string is made of. (1 mark)

String X : \_\_\_\_\_ String Y : \_\_\_\_\_

b) Which string is stronger? Explain your answer. (1 mark)

String : \_\_\_\_\_

Reason : \_\_\_\_\_

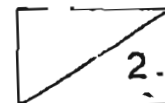

45. The experiment shown below was carried out.

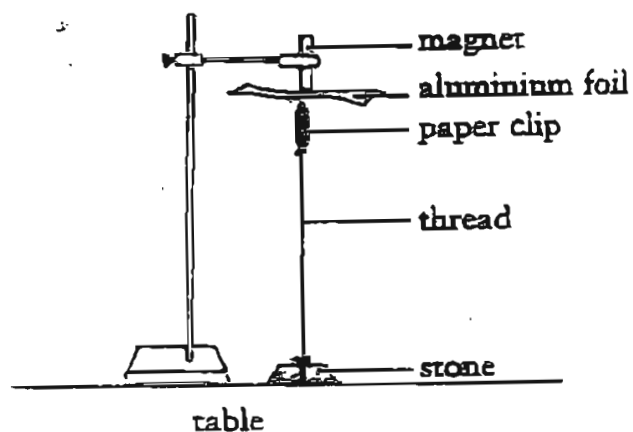

a) What would happen to the paper clip if the aluminium foil was replaced by an iron sheet? (1 mark)

---

b) Explain your answer in (a) above. (1 mark)

---

---

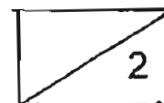

46. The diagram shows a shape formed by 4 bar magnets placed together.

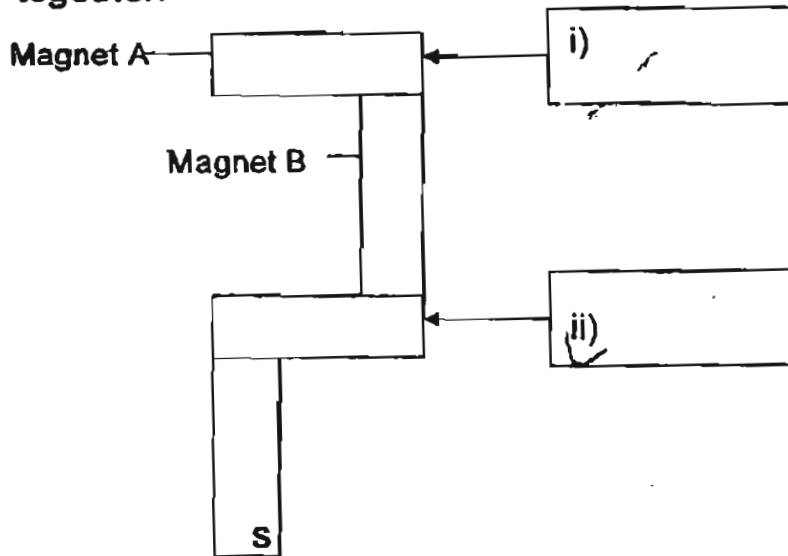

- a) Identify the poles of the other magnets by writing "S" for South pole and "N" for North pole. (1 mark)
- b) If Magnet A was replaced by a wooden rod and Magnet B was replaced by a steel bar, which one of the following shapes could be formed? (1 mark)  
Put a tick in the correct box below each diagram.

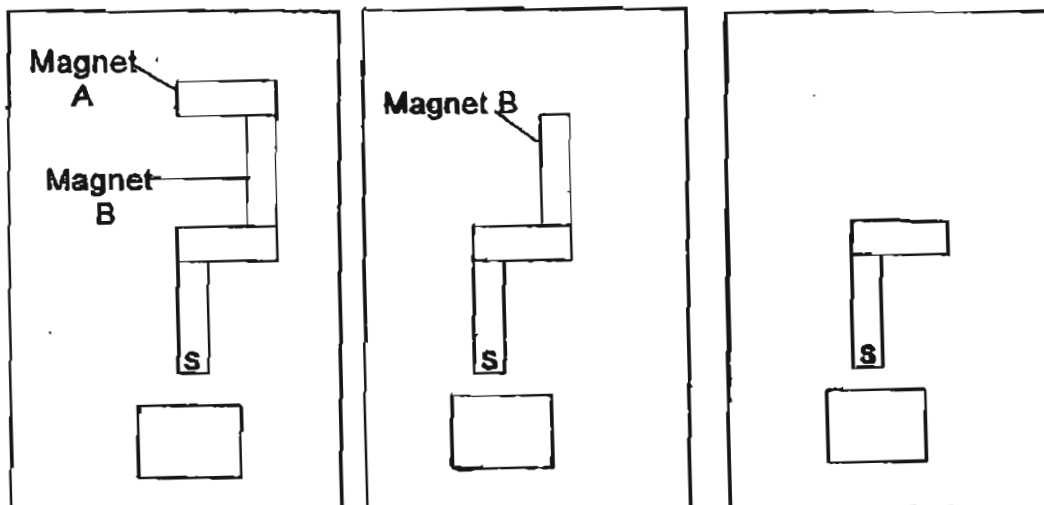

**END OF PAPER**



## Answer Sheets

### CHJ St Nicholas School / Pri 3 SA2/2005 Science

- 1)4      2)2      3)2      4)3      5)4      6)3  
7)2      8)2      9)3      10)3      11)4      12)4  
13)2      14)2      15)2      16)4      17)4      18)2  
19)2      20)4      21)2      22)1      23)3      24)3  
25)4      26)4      27)3      28)3      29)2      30)3

31)a. butterfly: -caterpillar      b. cockroach: -nymph      c. frog: -tadpole

d. mosquito: -larva      e. sheep: -lamb

32)a. lives on water      bi. Allamanda      bii. A

33)a. bud      b)stem      34)a. B:stomach      D:long intestine      b)C

35)

Edible Plant Part	Plant
Flower	Chrysanthemum
Fruit	Mangosteen
Leaf	Lettuce
Root	Sweet Potato

36)a. They both belongs to the birds family.

36)b. The pigeon can fly, but the ostrich cannot fly.

37)a. T      b. F      c. T

38)a. skull      b. rib cage      c. back bone

38)b. It protects our delicate organs.

39)a. It needs warmth      b. It needs water      c. It need air.

39)b. It gets its food from the seed leaves.

40)a. microscope      b. useful      c. diseases

41)a. True      b. Not possible to tell      c. False

42)B-D-C-A-E      43)a. D      b. A      c. C

44)a. string X: cotton      string Y: nylon

# Answer Sheets

CHIJ St Nicholas School / Pri 3 SA2/2005 Science

44)b. string Y String Y required more weights to bears it than string x.

45)a. The paper clip will drop.

45)b. Magnetic force cannot pass through the iron sheet.

46)i. South pole

ii) North pole

46)b.

Magnet  
B

