

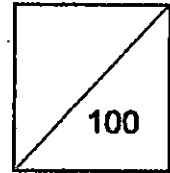

**HENRY PARK PRIMARY SCHOOL
2015 SEMESTRAL EXAMINATION 1
SCIENCE
PRIMARY 5**

Duration of Paper: 1 h 45 min

Name: _____ ()



Class: Pr 5 _____

Parent's Signature: _____

Booklet A (60 marks)

For each question from 1 to 30, four options are given. One of them is the correct answer. Make your choice (1, 2, 3 or 4). Shade the correct oval (1, 2, 3 or 4) on the Optical Answer Sheet.

1. The diagram below shows a pump connected to a glass jar. The capacity of the jar is 300 cm^3 .

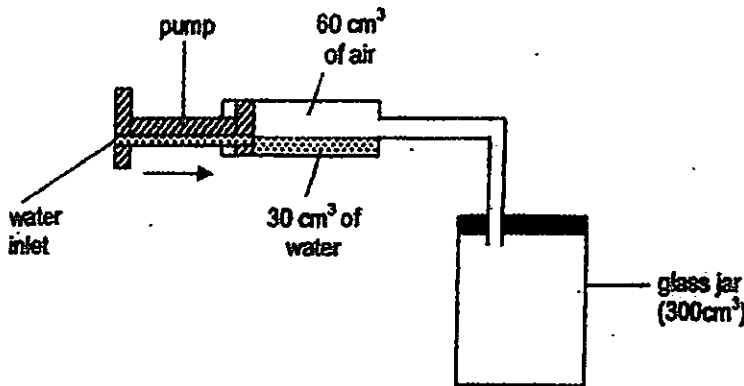

When the pump is pushed completely in, 60 cm^3 of air and 30 cm^3 of water is forced in. What is the volume of air in the glass jar now?

- (1) 210 cm^3
- (2) 240 cm^3
- (3) 270 cm^3
- (4) 300 cm^3

()



2. A beaker of water was heated over a bunsen burner for 30 minutes. During the period some ice cubes were put into the beaker of water.

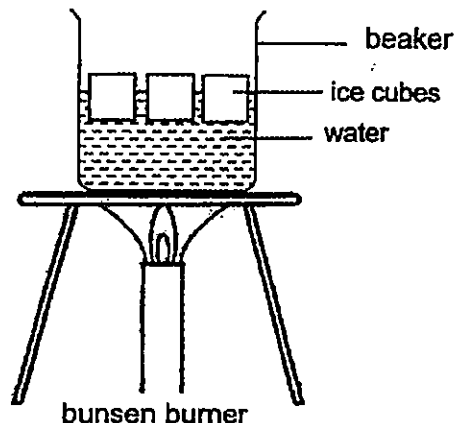

Which of the following changes will most likely take place after the ice cubes were put in?

- A: Ice cubes melt.
- B: Water evaporates.
- C: Temperature of water changes.

- (1) A only
- (2) B only
- (3) A and B only
- (4) A, B and C

()

3. Lynn measured and recorded the changes in the temperature of tap water in a beaker over a period of time and plotted the graph below.

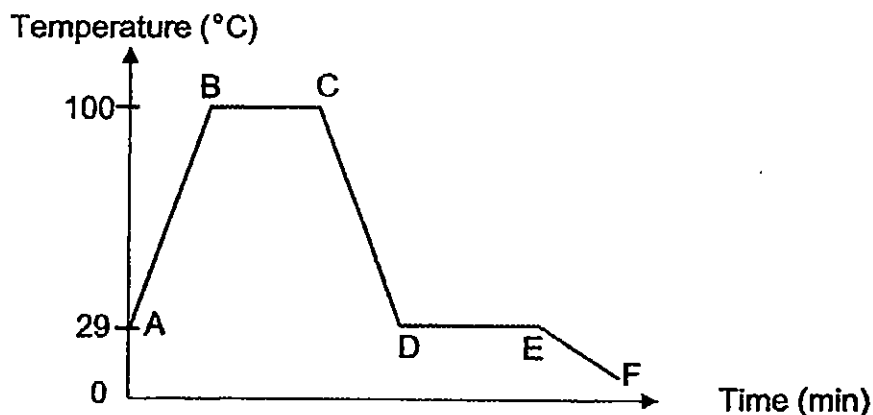

Which one of the following statements is not correct?

- (1) Water at DE is boiling.
- (2) Water is losing heat at CD.
- (3) Water at Point A is likely to be at room temperature.
- (4) Water at BC and DE has constant temperature.

()



4. The table shows the freezing point and boiling point of substance, X, Y and Z.

Substance	Freezing Point (°C)	Boiling Point (°C)
X	10	50
Y	50	145
Z	-10	35

Jim recorded his observation of X, Y and Z at a **certain temperature** in the table below.

	X	Y	Z
Has fixed volume?	yes	yes	no
Has fixed shape?	no	yes	no

What is the most likely temperature for all the 3 substances, X, Y and Z?

- (1) 5°C
- (2) 45°C
- (3) 80°C
- (4) 100°C

()

5. Jill bought a hot bun and put it inside a Ziploc bag and sealed it. A few minutes later, she noticed some water droplets inside the Ziploc bag. Which one of the statements best explains her observation correctly?

- (1) Steam was seen coming out of the Ziploc bag.
- (2) Water vapour evaporated and formed water droplets.
- (3) Water droplets condensed to become water vapour.
- (4) Water vapour condensed on the inside of the Ziploc bag.

()



6. Claudia heated a pot of tap water in her kitchen for 10 minutes until it started boiling. She continued boiling it for 10 minutes before adding a packet of instant noodles into the water.

Which of the following graphs shows the changes in the temperature of water correctly?

(1)
Temperature (°C)

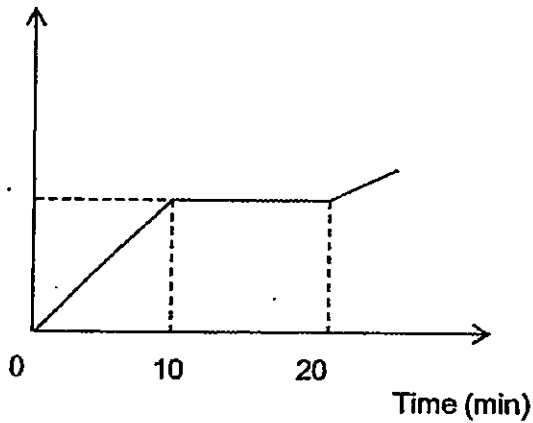

(2)
Temperature (°C)

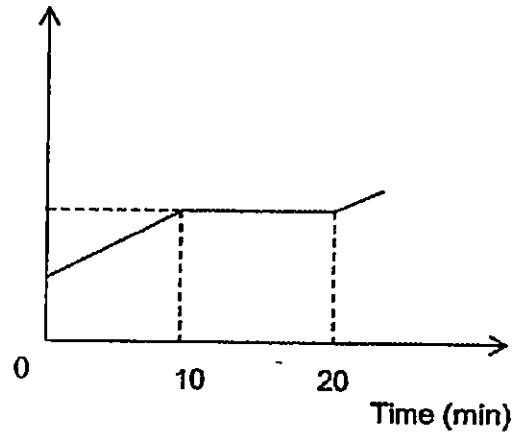

(3)
Temperature (°C)

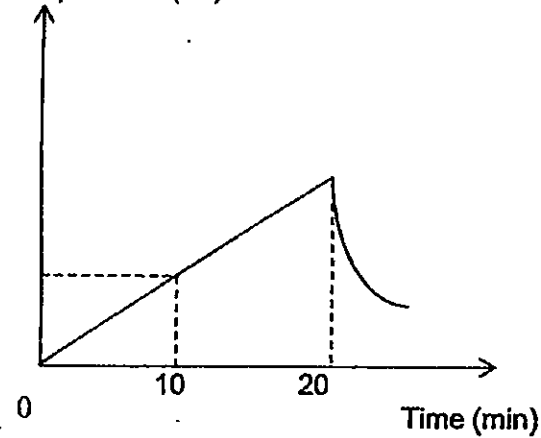

(4)
Temperature (°C)

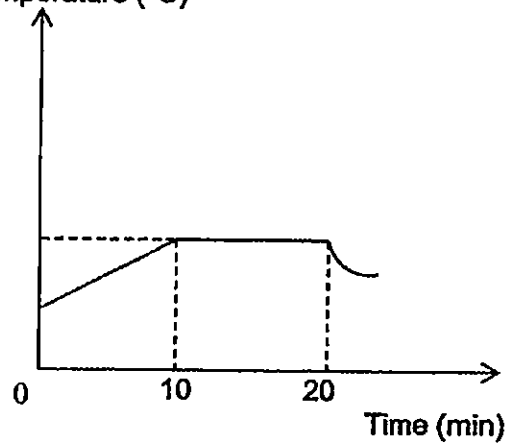

()



7. The figure below shows three similar containers, A, B and C, placed on a table with room temperature at 29°C . Each of the containers contains water at different temperatures.

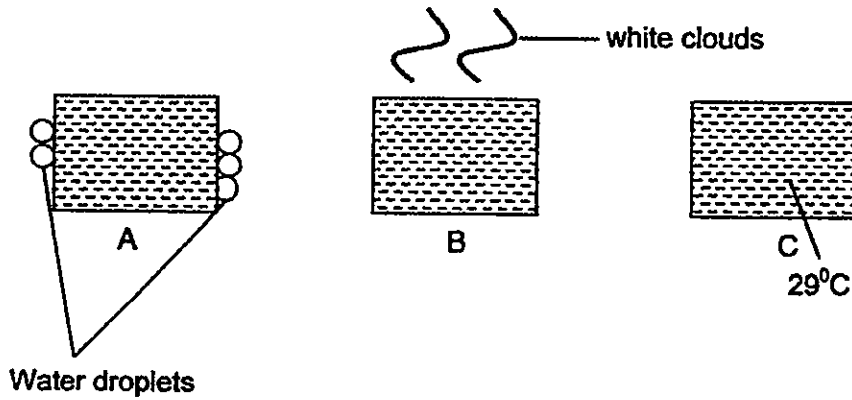

Water in Container C is about 29°C .

Which of the following states the correct temperature of water in Containers A and B?

	Container A	Container B
(1)	10°C	95°C
(2)	95°C	10°C
(3)	15°C	30°C
(4)	10°C	10°C

()



8. The diagram below shows a water cycle. W, X, Y and Z show change in states of water during which heat is gained or lost.

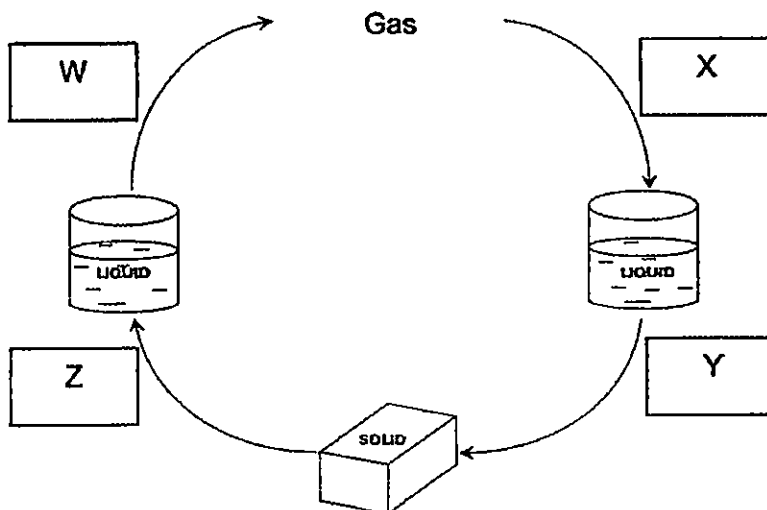

Which one of the following correctly represents W, X, Y and Z?

	W	X	Y	Z
(1)	Heat Loss	Heat Loss	Heat Gain	Heat Gain
(2)	Heat Gain	Heat Loss	Heat Loss	Heat Gain
(3)	Heat Gain	Heat Gain	Heat Loss	Heat Loss
(4)	Heat Loss	Heat Gain	Heat Loss	Heat Gain

()



9. Mary performs the following experiment on evaporation.

She fills three beakers with an equal volume of different liquids X, Y and Z as shown below. She places the three beakers in an open field, where it is sunny and windy.

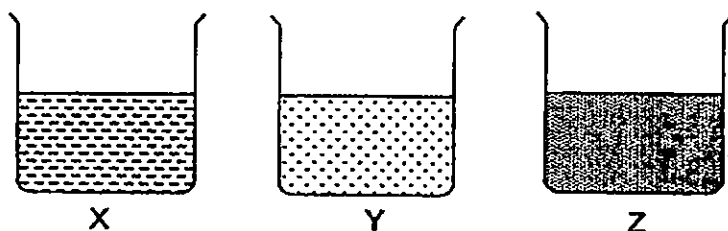

After two hours, she records the volume of liquid remaining in each of the three beakers.

What is the independent variable of this experiment?

- (1) Type of liquid
- (2) Strength of wind
- (3) Exposed surface area of water
- (4) Temperature of surrounding air

()

10. An experiment was set up to investigate condensation of water vapour. The same amount of hot water at 90°C or cold water at 10°C was poured into four similar steel cups.

Which one of the following correctly shows where water droplets would likely be observed after one minute?

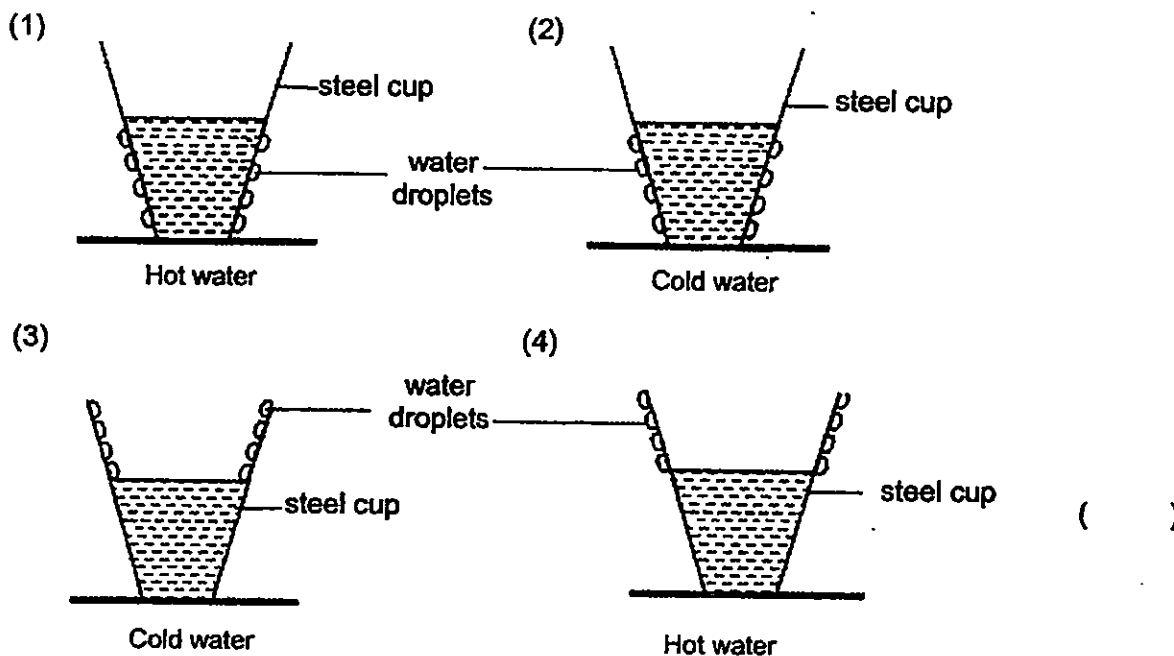

()



11. Jovan filled beaker A with small stones and beaker B with 30 ml of water.

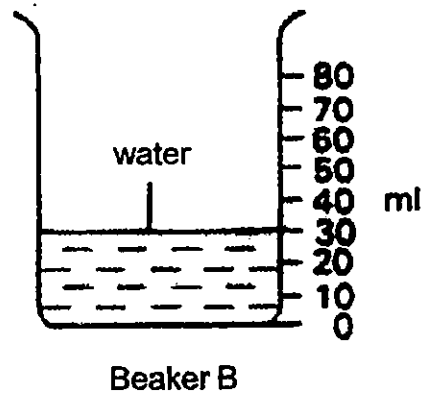
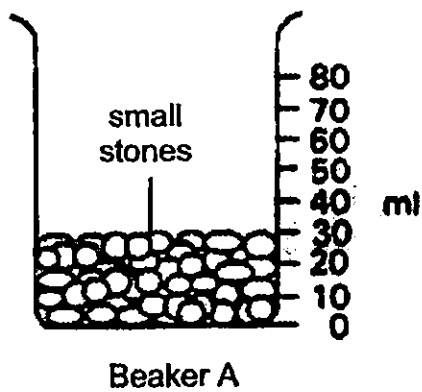

Which one of the following diagrams most likely shows the water level in Beaker A after all the water from Beaker B has been poured into it?

(1)

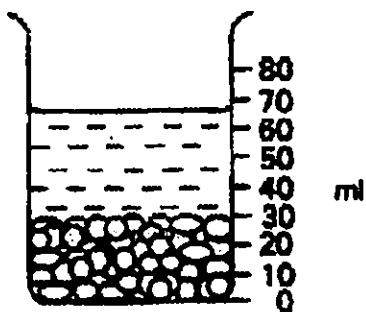

(2)

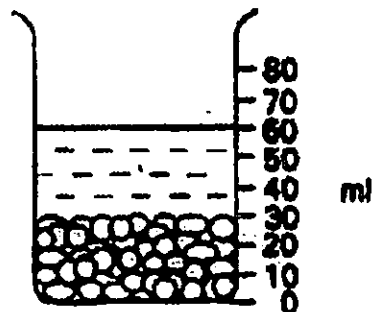

(3)

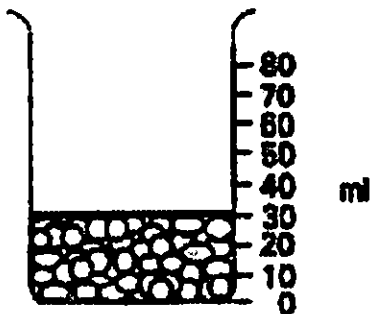

(4)

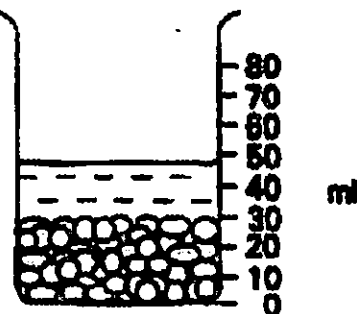

()



12. Observe the diagram of the life cycle of a flowering plant below.

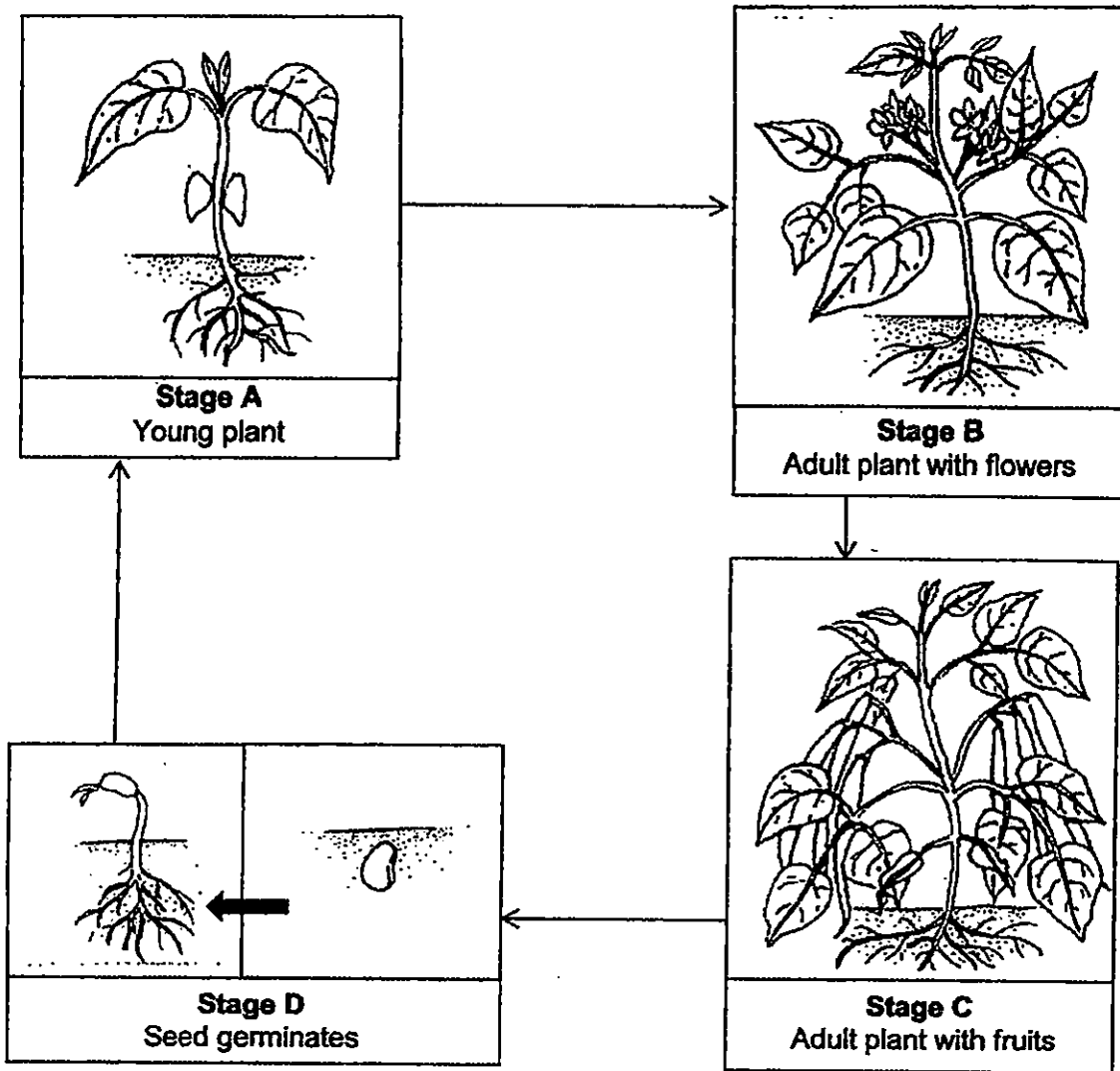

At which stage A, B, C or D of its life cycle has fertilisation **definitely** taken place?

- (1) A
- (2) B
- (3) C
- (4) D

()



13. The diagram below shows flowers A, B, C and D. Pollen grains from flowers of the same type were dusted over each flower.

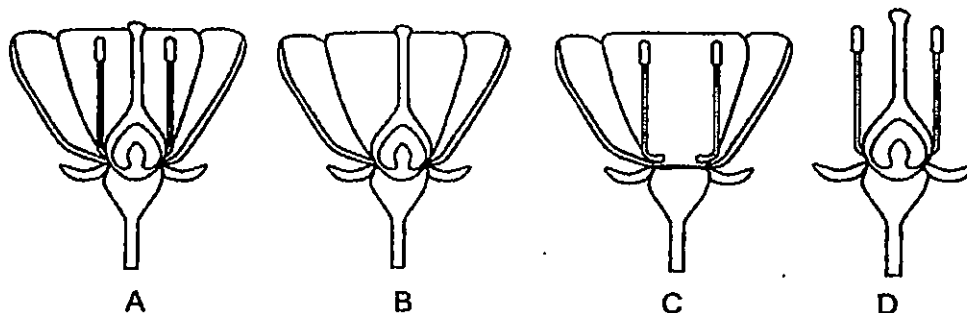

Which of the above flower(s) is/are likely to develop into a fruit?

(1) C only

(3) A and D only

(2) B and C only

(4) A, B and D only

()

14. Jim recorded his observations about some flowers during his learning journey to the Singapore Botanic Gardens in the table below.

Flower	Size of petals	Colour of petals	Sweet scent	Presence of nectar
W	Small	Dull	No	No
X	Large	Bright	Yes	Yes
Y	Small	Bright	Yes	Yes
Z	Large	Dull	Yes	No

Based on his data, the pollen grains from which flower(s) is/are likely to be sticky or spiky?

(1) X only

(2) X and Y only

(3) W and Z only

(4) W, Y and Z only

()

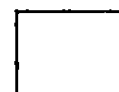

15. Tim wanted to conduct an experiment using five seeds of a plant to measure the time taken for each to reach the ground when dropped from a certain height.

Before he started the experiment, he recorded some data about the seeds in the table below.

Seed	Mass of seeds (g)	Number of wing-like parts	Length of wing-like parts (cm)
A	2	1	4
B	4	1	4
C	4	1	3
D	2	2	4
E	2	3	4

Which seeds can he use to find out how the number of wing-like parts will affect the distance the seeds will be dispersed?

- (1) A and B only
- (2) C and E only
- (3) A, D and E only
- (4) B, C and E only

()

The following diagrams are for questions 16 and 17.

16. Observe the diagrams of the human and plant reproductive systems below.

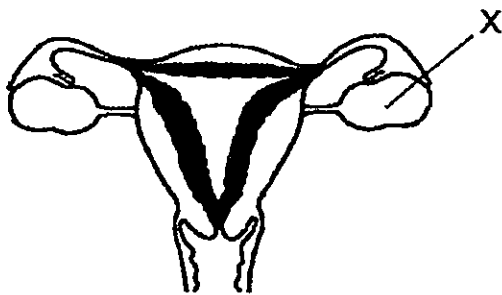

Human

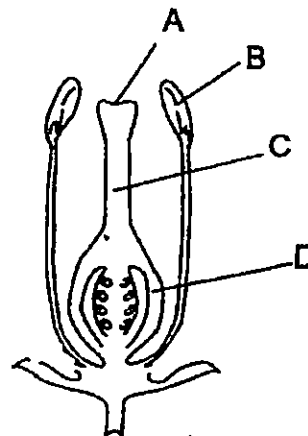

Which part(s) of the plant reproductive system perform(s) the same function as that of part X?

- (1) A only
- (2) B only
- (3) D only
- (4) A, C and D only

()



17. After fertilisation, what will happen to the reproductive plant part that you have identified in question 16?

- (1) It turns brown.
- (2) It will become the fruit.
- (3) It dries up and falls off.
- (4) It will become the seeds.

()

18. Jim found the fruits of two plants and recorded his findings in the table.

Plants	Description of fruit
P	Small seeds, fleshy and sweet
Q	Hard, dry pod with small seeds

Study the diagram below that shows the possible patterns of the growth of new plants P and Q on a piece of land.

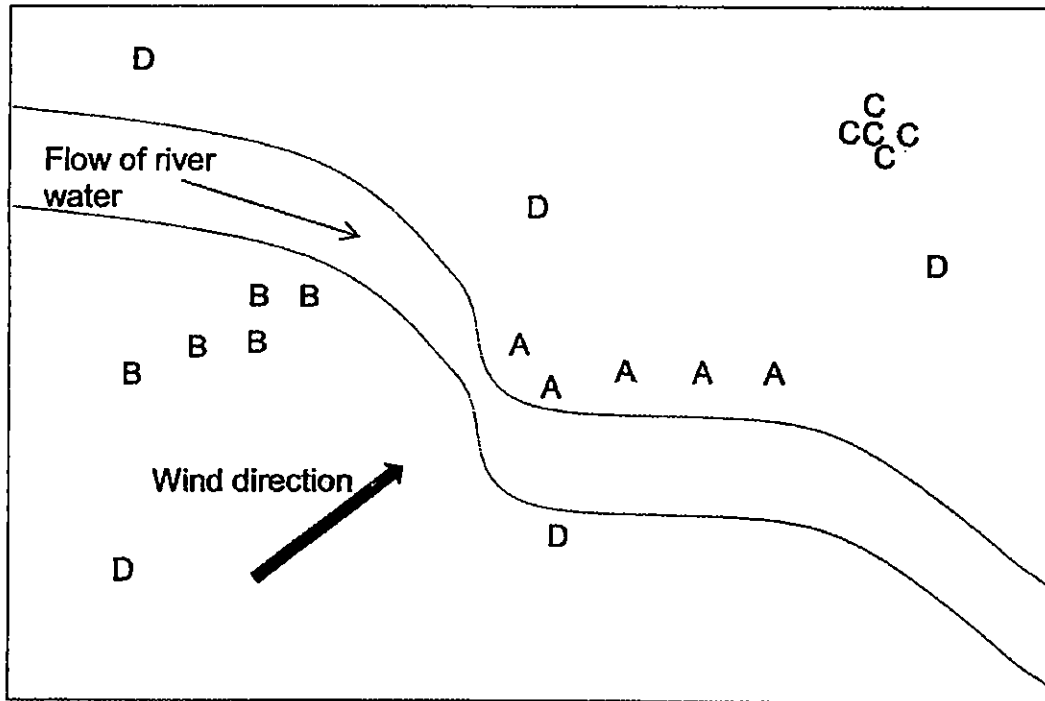

Which one of the letters, A, B, C or D represents the pattern of the growth of new plants P and Q that Jim is likely to observe after some time?

	Plant	
	P	Q
(1)	D	C
(2)	C	D
(3)	B	A
(4)	D	A

()

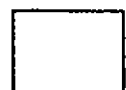

19. Ben observed four different plants and recorded the data in the table below. He placed a tick (✓) when the characteristic was observed.

Plant	Characteristics observed		
	Lives on land	Lives in water	Has spores
W	✓		
X		✓	✓
Y		✓	
Z	✓		✓

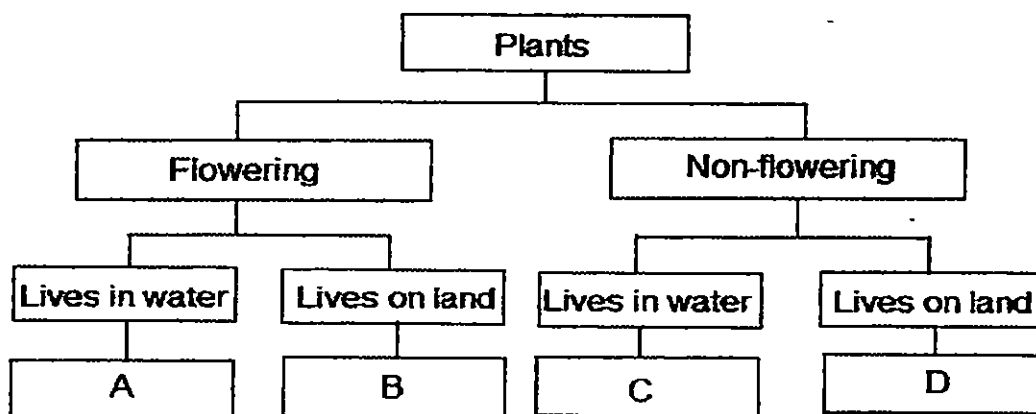

Based on his data, which one of the following correctly classifies the four plants?

	A	B	C	D
(1)	X	Z	Y	W
(2)	Y	W	X	Z
(3)	Z	Y	W	X
(4)	W	X	Z	Y

()



20. Peter wanted to find out if overcrowding affects the germination of seeds. He conducted the experiment using 4 similar pots, A, B, C and D.

Variables	A	B	C	D
Duration of experiment	3 days	5 days	5 days	5 days
Location	In the room	In the room	In the field	In the room
Number of seeds	10	10	30	30
Amount of water given daily (ml)	10	20	10	20
Amount of soil (g)	500	300	500	300

Which two pots should Peter choose to ensure that his experiment is a fair test?

- (1) A and B only
- (2) A and C only
- (3) B and D only
- (4) C and D only

()

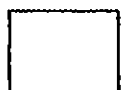

Study the water cycle below and answer questions 21 and 22.

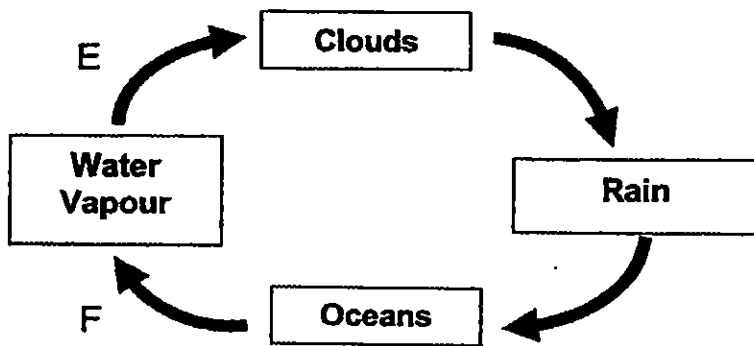

21. Which of the following represents the processes, E and F, respectively?

	E	F
(1)	Evaporation	Melting
(2)	Evaporation	Condensation
(3)	Condensation	Evaporation
(4)	Freezing	Condensation

()

22. Which of the following are correctly matched to the processes, E and F of the above water cycle?

	E	F
(1)	Heat gain	Heat gain
(2)	Heat gain	Heat loss
(3)	Heat loss	Heat gain
(4)	Heat loss	Heat loss

()



23. Alex lowered a metal block at 60°C into a container of water at 90°C as shown below.

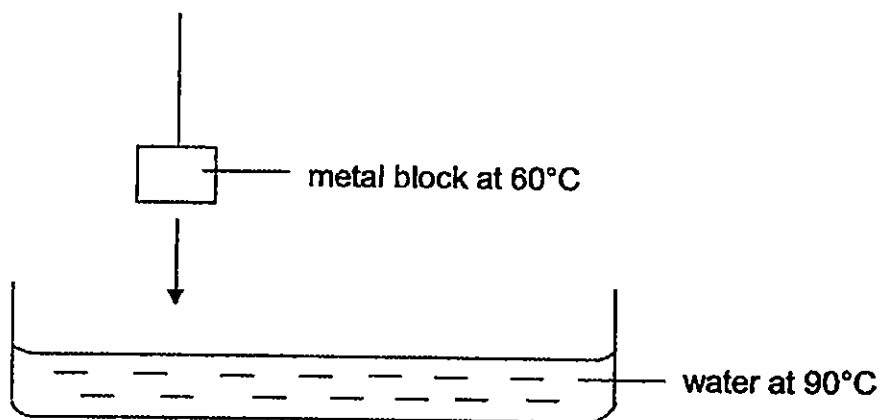

Which of the following statements shows correctly what Alex would observe after a few minutes?

- (1) The temperature of water decreased.
- (2) The temperature of water increased.
- (3) There was no change in the temperature of water.
- (4) The temperature of water increased, then decreased.

()

24. Which of the following would cause **water pollution**?

- A: Recycling water
- B: Dumping waste into the sea
- C: Littering into lakes and rivers
- D: Treatment of dirty water before releasing it into the sea

- (1) A and B only
- (2) B and C only
- (3) A, B and C only
- (4) A, C and D only

()



25. The diagram below shows the process of reproduction in humans.

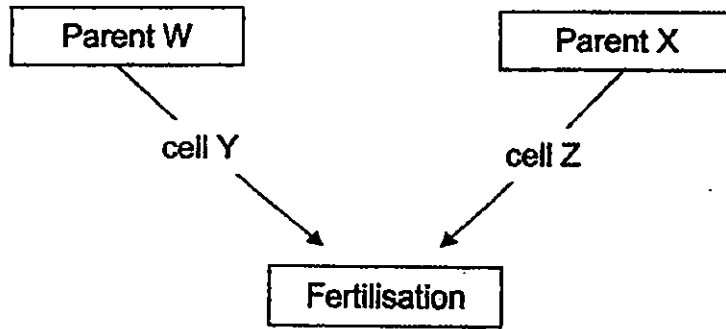

Which one of the following correctly states what W, X, Y and Z are?

	Parent W	Parent X	cell Y	cell Z
(1)	male	female	egg	sperm
(2)	female	male	sperm	sperm
(3)	male	female	sperm	egg
(4)	female	male	egg	egg

()

26. Which of the following statements are correct?

- A: Living things reproduce to ensure the continuity of their own kind.
- B: Only animals pass their characteristics to their young.
- C: Sexual reproduction process in humans involves two parents.

- (1) A and B only
- (2) B and C only
- (3) A and C only
- (4) A, B and C

()



27. Mary observed and recorded some physical characteristics of her two dogs and their puppy in the table shown below.

Physical Characteristics	Male Dog	Female Dog	Puppy
Long fur	No	Yes	Yes
Short tail	Yes	No	Yes
Black spots	Yes	No	No
V-shaped ears	No	Yes	Yes

Which of the following statements based on the above table are correct?

The puppy _____.

- A: inherited its male parent's long fur.
- B: did not inherit its male parent's black spots.
- C: did not inherit its female parent's V-shaped ears.
- D: inherited at least one characteristic from each of its parent.

- (1) A and B only
- (2) A and C only
- (3) B and D only
- (4) C and D only

()

28. Which of the following statements about heat are correct?

- A: Heat is matter.
- B: Heat is a form of energy.
- C: Our main source of heat is from the lamps.
- D: Heat moves from a hotter place to a cooler place.

- (1) A and C only
- (2) B and D only
- (3) A, B and C only
- (4) B, C and D only

()

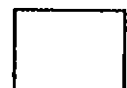

29. Paul wanted to find out which cup, each made of a different material, is a better conductor of heat. He poured the same volume of water into the cups. He measured the temperature of the water in the cups every minute.

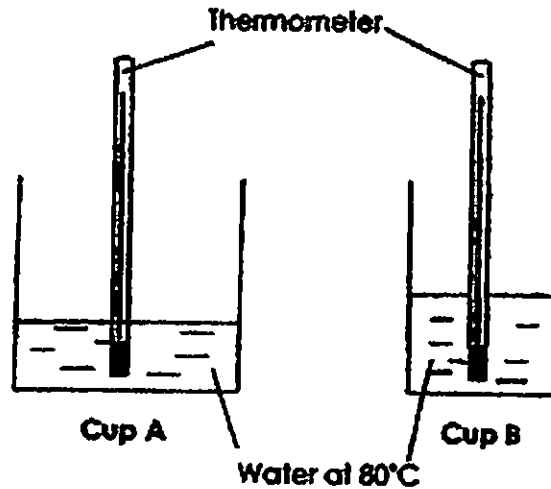

Paul's teacher said that his experiment was not a fair one. Explain why.

- (1) Size of the cups were different.
 - (2) The volume of water is the same.
 - (3) The temperature of water is the same.
 - (4) Cup A and Cup B were made of different materials.
- ()
30. Janet wants to separate the two glasses, A and B, which are stuck together as shown below.

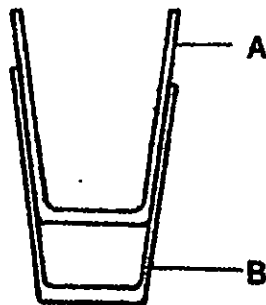

What should Janet do to separate the two glasses?

- A: Pour hot water in A
- B: Pour cold water in A
- C: Place B in hot water
- D: Place B in cold water

- (1) A and C
 - (2) A and D
 - (3) B and C
 - (4) B and D
- ()

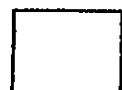

**HENRY PARK PRIMARY SCHOOL
2015 SEMESTRAL EXAMINATION 1
SCIENCE
PRIMARY 5**

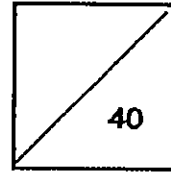

Name: _____ ()

Class: Pr 5: _____

Booklet B (40 marks)

Write your answers to questions 31 to 44 in the spaces given.

31. Study the classification table below.

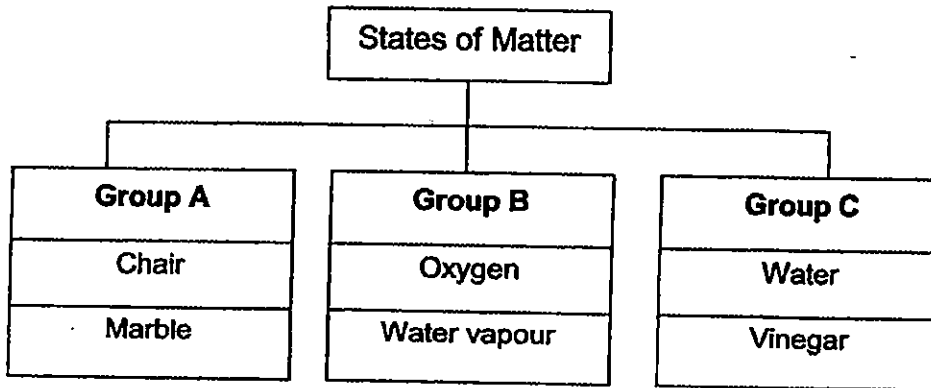

a) State suitable headings for Groups B and C.

(1m)

Group B: _____

Group C: _____

b) State **one** difference in the property of matter in Group A and B:

(1m)



32. John heated two containers, X and Y, with the same amount of tap water. He also placed 2 identical mirrors at the same angle above each beaker as shown below.

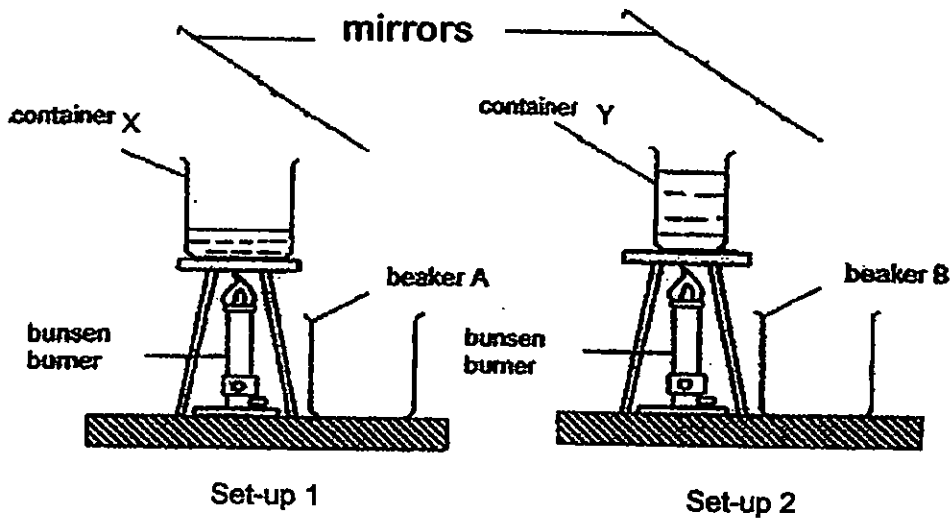

After an hour, John found water collected in Beakers A and B.

- a) Explain how the water was collected in both beakers.

(2m)

- b) During the experiment more water was collected in Beaker A. Explain why

(2m)



33. The diagrams below show two types of swimming pool.



**Outdoor pool
(without shelter)**



**Indoor pool
(with shelter)**

- a) The floor area around the outdoor pool is likely to be **drier** on a sunny day. (2m)
Explain why.

- b) Children at the indoor pool tend to slip easily when walking around the pool.
Explain how adding fans around the indoor pool reduces the number of children slipping. (1m)

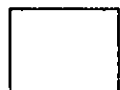

34. Two glasses of water (at room temperature and of the same volume) are placed in the refrigerator and the freezer at the same time.

The graphs below show changes of the temperature of water for duration of forty minutes.

- a) Write 'Refrigerator' or 'Freezer' in the correct boxes in the graphs below.

(2m)

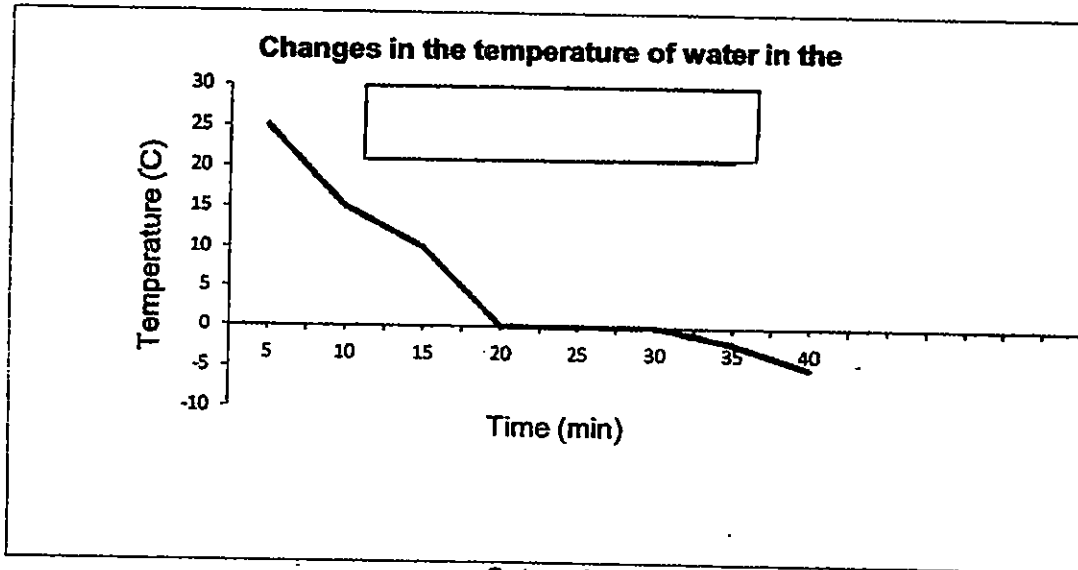

Set-up A

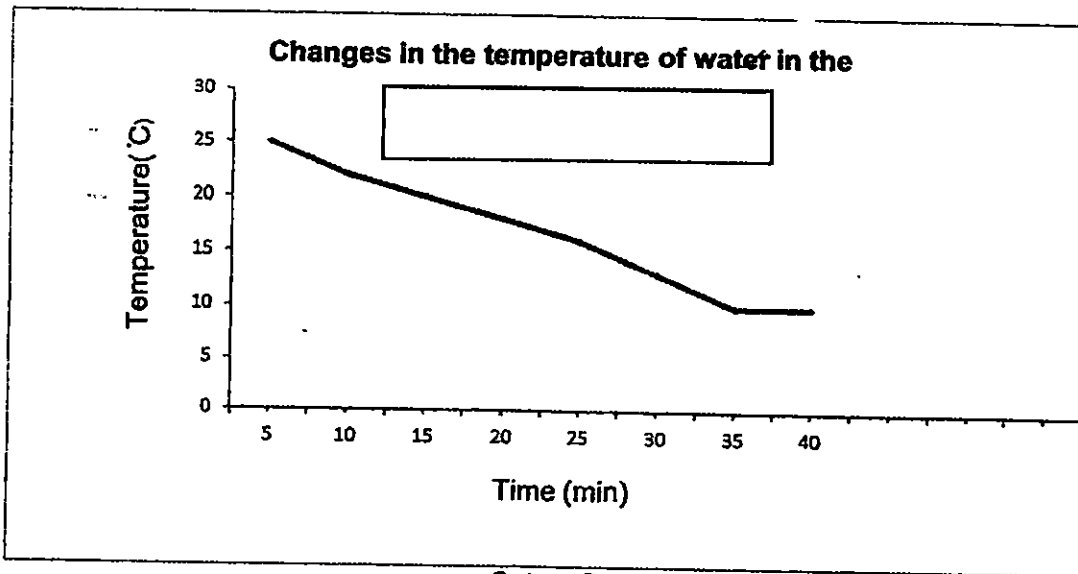

Set-up B

- b) What is the state of water in the glass in Set-up B between 35th and 40th minute? (2m)
Give a reason for your answer.



35. The diagrams below show the water cycle and the drying of a wet T-shirt.

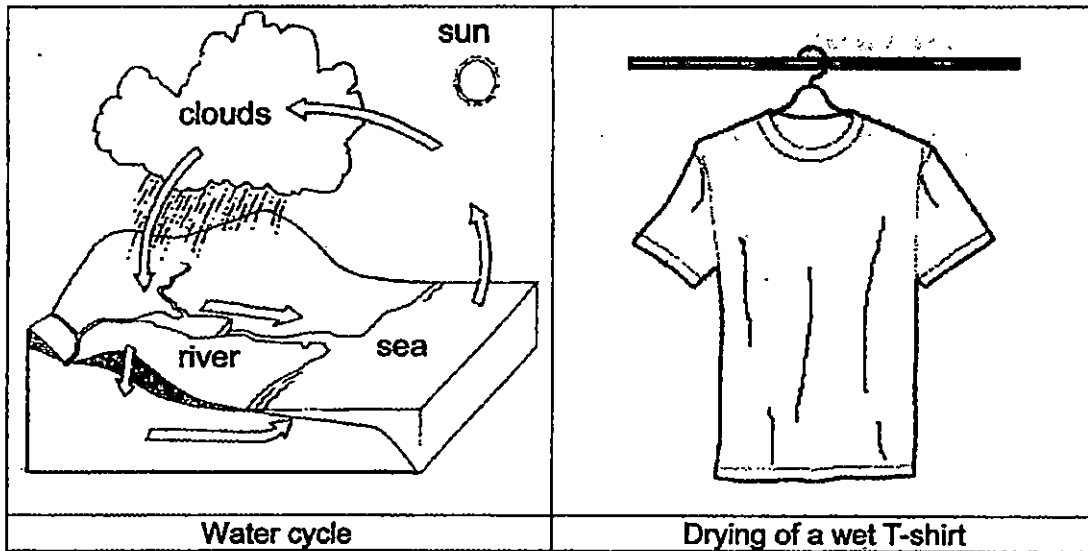

a) Name the process that is observed in both the water cycle and the drying of the wet T-shirt. (1m)

b) State two factors that can slow down the rate of evaporation of water. (2m)

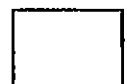

36. Study the family tree below carefully.

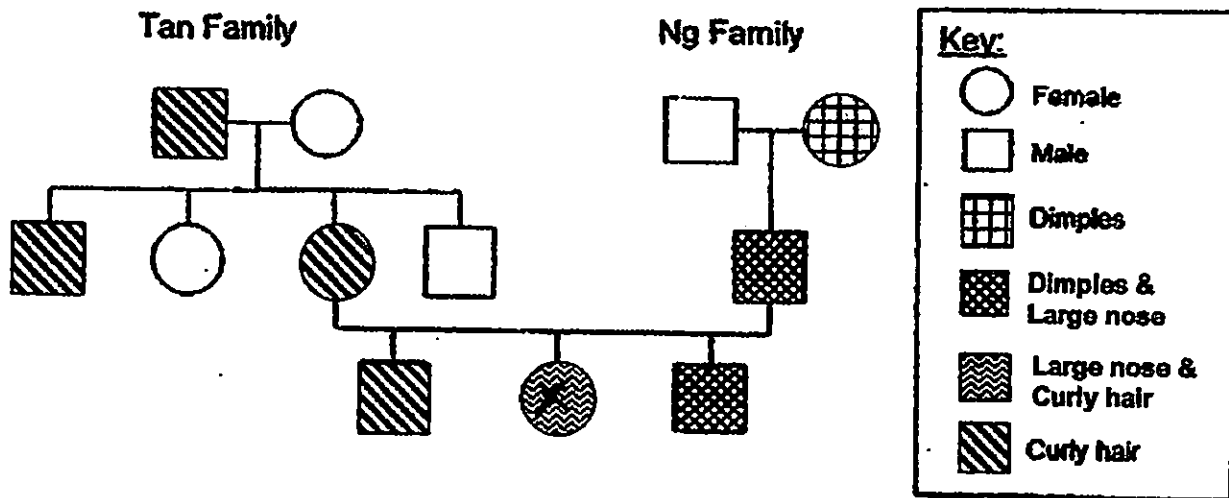

a) Rachel is the daughter of Andrew Ng and Mary Tan. Write 'X' to indicate Rachel on the family tree above. (1m)

b) What feature did Rachel's father have that she did not inherit? (1m)

c) What feature did Rachel inherit from her mother? (1m)

37. The following table shows the comparison between sexual reproduction in humans and in flowering plants.

Complete the table below by writing the correct word in each blank (2m)

	Humans	Flowering plants
Where male reproductive cell is produced	Testes	(a) _____
What happens after fertilisation	A foetus will develop in the (b) _____	The (c) _____ develops into a seed and the (d) _____ begins to swell.



38. John has four beakers of water as shown below.

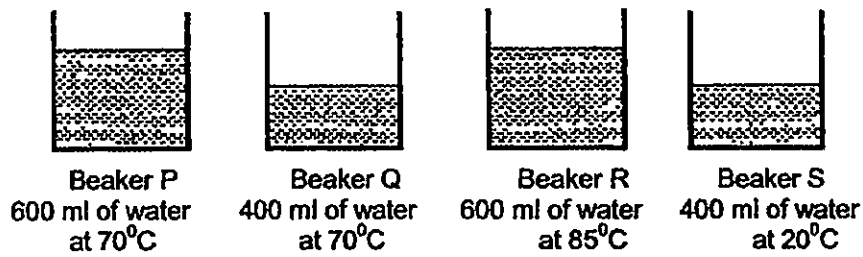

a) Arrange the beakers, P, Q, R and S, in descending order according to the amount of heat they contain. (1m)



b) John wants to find out if the amount of water affects the amount of heat in each beaker. Which two set-ups should he use? (1m)

c) Name an instrument that is used to measure the temperature of water in each beaker accurately. (1m)



39. Mandel slotted four similar rings into a plastic rod and they came to rest in the positions shown below.

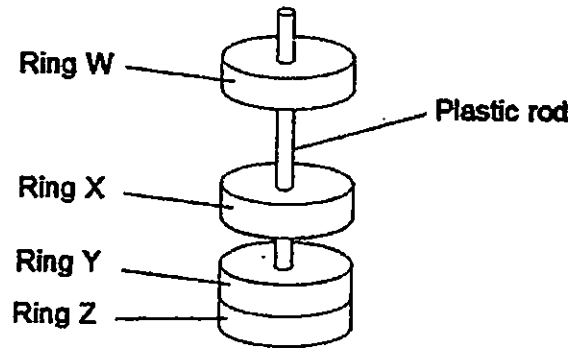

Four statements were made based on the above set-up.

In the table below, put a tick (✓) under the correct heading to indicate if the statements are 'True', 'False', or 'Not Possible to Tell'. (2m)

Statement		True	False	Not possible to tell
(i)	All the four rings are definitely magnets.			
(ii)	Ring Z is made of iron.			
(iii)	The like poles of Rings W and X are facing each other.			
(iv)	Ring Y is made of plastic.			

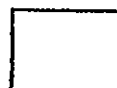

40. The diagram below shows the part of a flower.

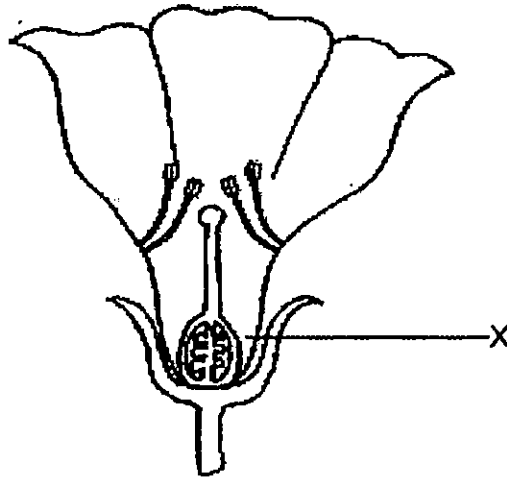

(2m)

'X' shows where nectar is found in the flower.
Explain how this helps the flower to be pollinated by insects.

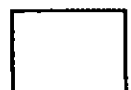

41. Pete set up the experiment below to investigate the germination of bean seeds.

He soaked 2 similar-sized balls of cotton wool in the same volume of water, and attached the same number of bean seeds in each ball of cotton wool.

He then placed both set-ups under a lighted lamp for 5 days.

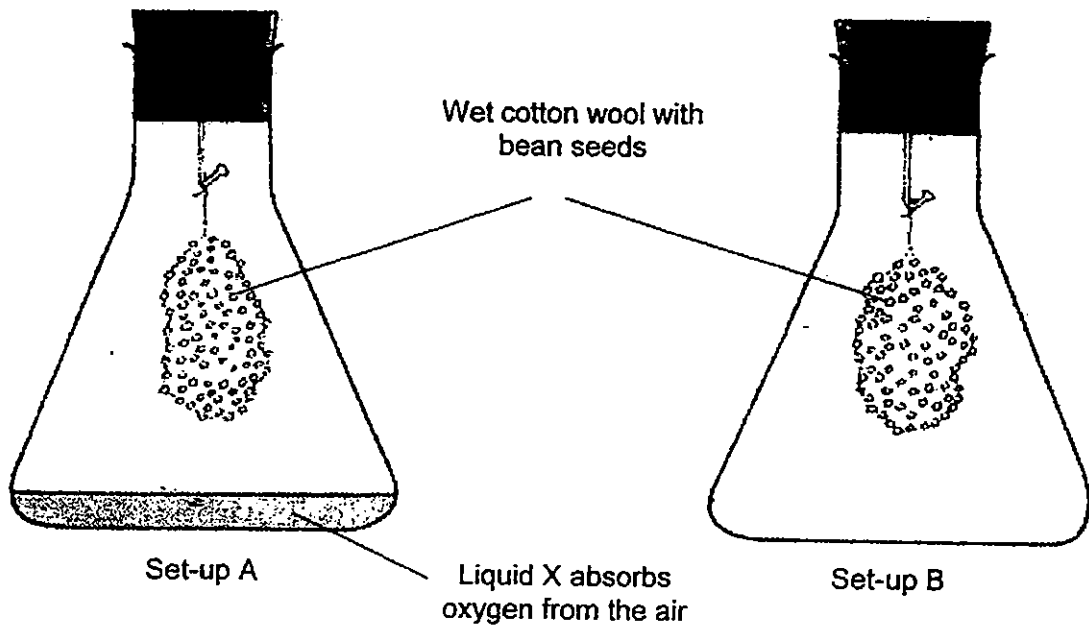

a) What is the purpose of the lighted lamp in the experiment above? (1m)

b) State one **other** variable he had kept the same to conduct a fair test. (1m)

c) The bean seeds from which set-up (A or B) is not likely to germinate? Give a reason for your answer. (1m)

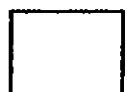

42. Observe the characteristics of the seeds below carefully.

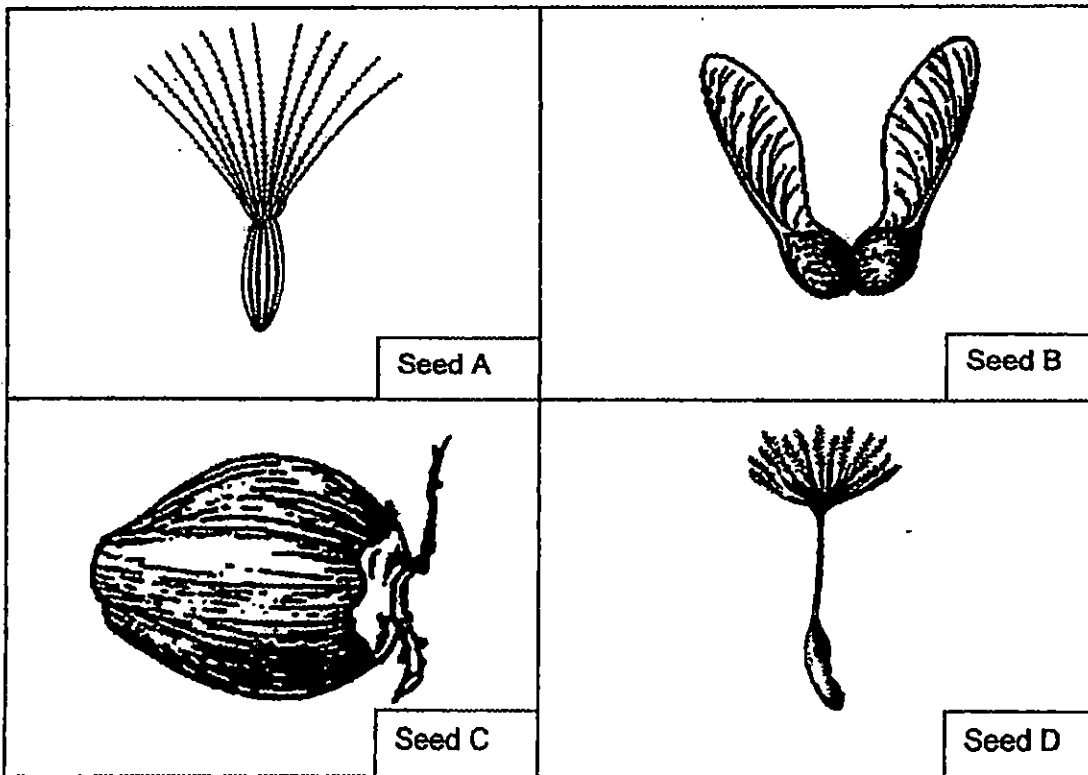

a) Which one of the seeds is likely to be dispersed differently from the rest? (1m)

b) Explain clearly your answer in (a). (2m)

c) How is seed B dispersed? Based on your observation, give a reason for your answer. (1m)



43. Small animals help plants disperse their seeds when they eat the fruit and swallow the seeds.

The seeds are often found in the animals' droppings far away from the parent plants.

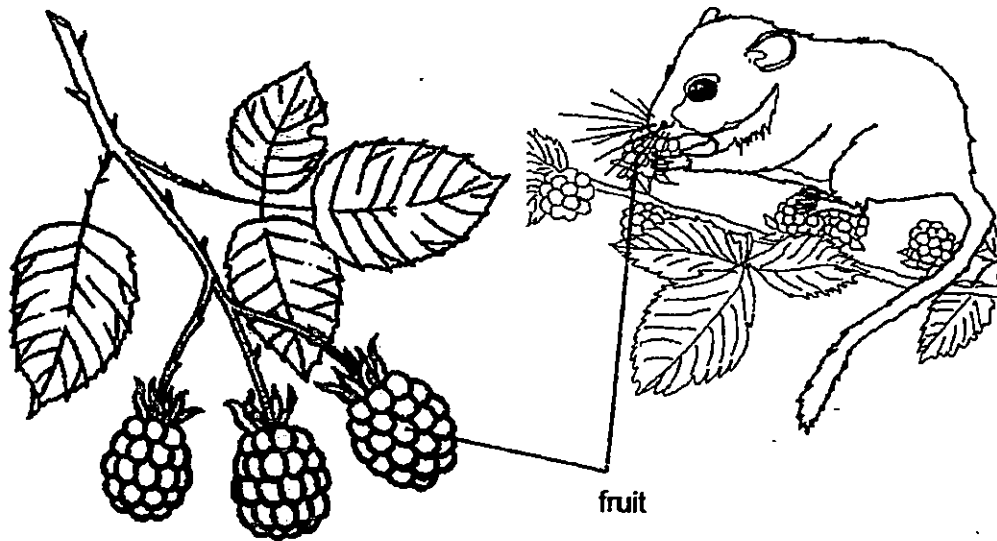

- a) State two characteristics of the seeds of these plants. (1m)

(i)

(ii)

- b) State one advantage to the plants when its seeds are carried far away from the parent plant. (1m)



44. The diagram below shows the layout of Jen's house and garden. There are six adult fruit trees growing, on each side of the West and East side of the garden. Jen noticed a small beehive in one of the trees growing on the East side.

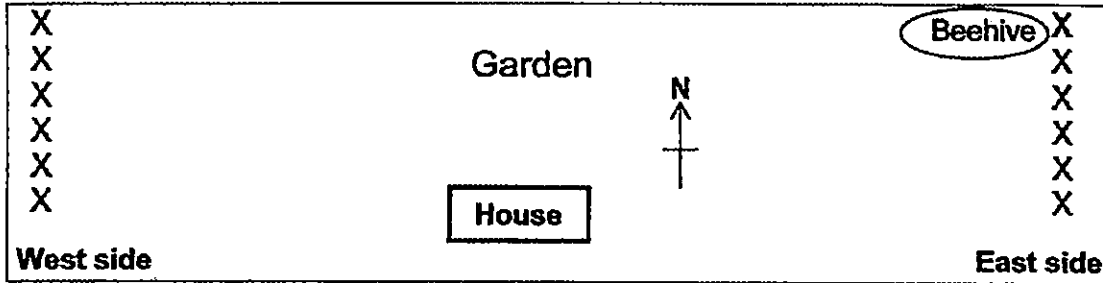

Legend

X : Fruit trees

Jen observed the number of flowers and fruits from all her fruit trees over a four-year period (2011 - 2014) and recorded the numbers in the table below.

Year	Trees in the West side		Trees in the East side	
	Number of flowers	Number of fruits	Number of flowers	Number of fruits
2011	29	10	24	23
2012	34	12	33	33
2013	42	15	42	39
2014	38	9	36	35

- a) Which side of the garden, West or East, produced more fruits over the four years? (1m)

- b) Suggest a reason for your answer in (a). (2m)

End of Booklet B

Setters: Mr Nelson Tong
Mdm Cecilia Quah
Ms Rebecca Lo





LEVEL : PRIMARY 5
SCHOOL : HENRY PARK PRIMARY SCHOOL
SUBJECT : SCIENCE
TERM : SA1

Q1	Q2	Q3	Q4	Q5	Q6	Q7	Q8	Q9	Q10
3	4	1	2	4	4	1	2	1	2
Q11	Q12	Q13	Q14	Q15	Q16	Q17	Q18	Q19	Q20
4	3	4	2	3	3	2	1	2	3
Q21	Q22	Q23	Q24	Q25	Q26	Q27	Q28	Q29	Q30
2	2	1	2	3	3	3	2	1	3

Q31a. Group B : Gaseous Q31a. Group C: Liquid

Q32b. Group A has definite volume while Group B does not have definite volume.

Q32a. The water in container X and container Y will gain heat by the burner and evaporate into water vapour. The water vapour will lose heat and condense on the cool side of the mirror.

Q32b. Container X has a larger exposed surface area of water compared to container Y, hence container X will gain heat faster than container Y.

Q33a. Evaporation of water is faster as the surrounding temperature is higher.

Q33b. The increase of the amount of wind will make the water evaporate faster.

Q34a. SEE PICTURE

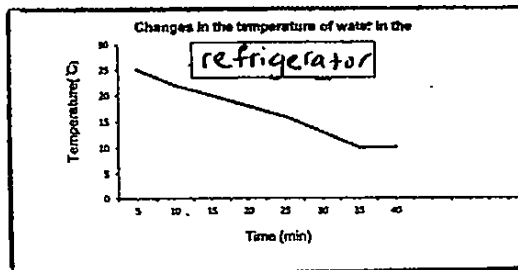
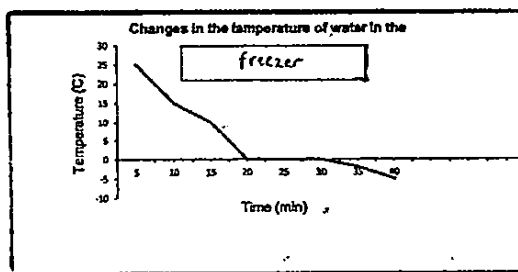

Q34b. Liquid. It has not reached the freezing point and just stop at the surrounding temperature.

Q35a. Evaporation Q35bi) The high humidity Q35bii) The low temperature

Q36a. SEE PICTURE

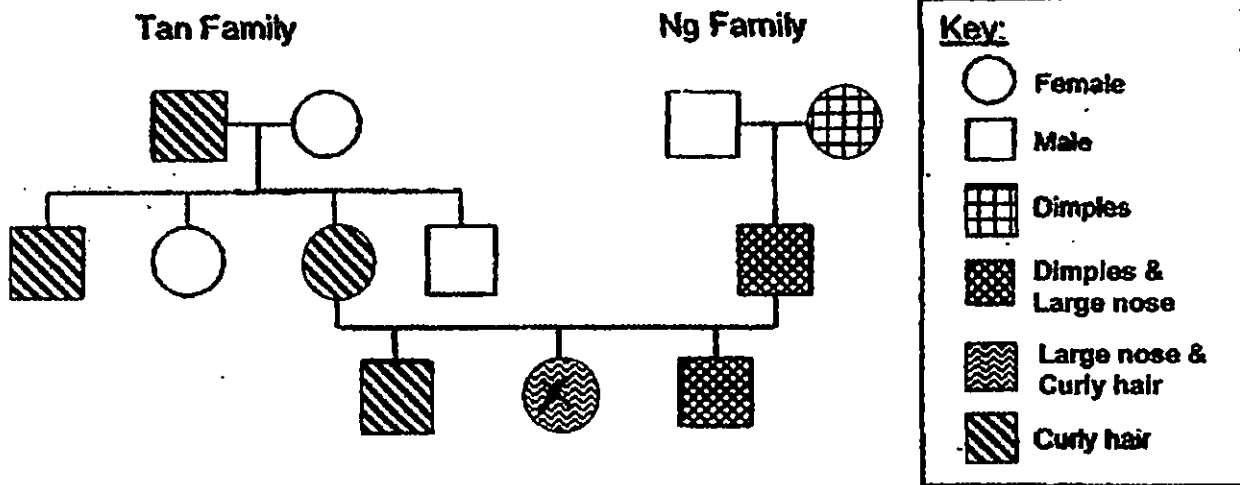

Q36b. His dimples Q36c. Her curly hair.

Q37a. Anther Q37b. womb Q37c. ovule Q37d. Stem

Q38a. R → P → Q → S

Q38b. Set up P and set up Q

Q38c. The thermometer

Q39ai) Not possible to tell

Q39aii) Not possible to tell

Q39aiii) TRUE

Q39aiv) FALSE

Q40. While the bee collects nectar from a flower, the pollen grain will stick onto the bee's body. When it goes to another flower, the pollen grain will land on the stigma.

Q41a. It provides warmth.

Q41b. Amount of water

Q41c. Set up A. It does not have oxygen to survive.

Q42a. Seed C

Q42b. A, B and D have wind like structure but seed C does not has.

Q42c. Seed B is dispersed by wind. It has wind like structure .

Q43ai) It is indigestible Q43aii) It is small

Q43b. No model answer

Q44a. Eastside Q44b. There is a beehive nearby and the bees will help with the pollination and fertilize faster.

THE END